

Issued: 06/06/86

Revised 11/02/07

WATEROUS

WATEROUS

SOUTH ST. PAUL, MINNESOTA

3 Inch Indicating Relief Valve Assembly

REF NO.	DESCRIPTION	REF NO.	DESCRIPTION
V2	Drain cock, 1/4 in. (used prior to 12/20/89)	V33	Switch ground wire assembly (used prior to 6/1/86)
V4	Valve spring	V34	Indicator light panel plate (used prior to 2/25/91) (Furnished as part of pilot valve after 2/25/91)
V5	Main valve	V35	Wiring harness (used prior to 4/21/06)
V6	Cover gasket	V36	Indicator light, green lens (closed) (used prior to 4/21/06)
V7	Valve cover	V37	Indicator light, amber lens (open) (used prior to 4/21/06)
V8	Valve body subassembly (includes seat V12 and sleeve V13)	V38	Light bulb, (12 volt - light No. 1891) (24 volt - light No. 313) (used prior to 4/21/06)
V9	Cap screw, 3/8-16 x 1 in.	V39	Actuator switch (used prior to 4/21/06)
V10	O-ring	V40	Connecting and sealing device (used prior to 6/1/86)
V11	Sq hd pipe plug, 1/4 in.	V40	Sealing grip (straight or 90° elbow) (used from 6/1/86 to 4/21/06)
V12	Seat	V41	Hex nut, No. 8-32 (not furnished by Waterous after 5/15/88)
V13	Sleeve	V42	Rd hd screw, SS, No. 8-32 x 3/8 in. (not furnished by Waterous after 5/15/88)
V15	Sq hd pipe plug, 1/4 in., brass (used prior to 7/15/96)	V43	Lock washer, No. 8 (not furnished by Waterous after 5/15/88)
V21	Switch actuating rod	V52	O-ring
V22	Actuating rod spring	V53	Adapter
V24	Switch mounting bracket	V54	Hex hd cap screw, 1/2-13 x 1-3/4 in., or Skt hd cap screw, 1/2-13 x 1-1/4 in.
V25	O-ring	V55	O-ring
V26	Plain copper washer, 3/8 in.	V56	Lock washer, 1/2 in.
V27	Groove pin, SS, 1/8 x 5/8 in.	V57	Sq socket pipe plug, 3/8 in.
V28	Flared coupling nut, 3/8 in. (used prior to 7/15/96)	V58	Soc hd cap screw, 5/16-18 x 1-3/8 in.
V29	Half union elbow, 1/4 pipe to 3/8 tube (used prior to 7/15/96)	V59	Complete replacement valve without wiring assembly
V30	Wiring assembly (includes items V31 thru V43 prior to 4/21/06) Not included with dual relief valves, see relief valve and piping assembly.	V60	Repair kit (consists of V6, V10, V25, V27, V52 & V55)
V31	Wire assembly (used prior to 4/21/06)	V61	Compression fitting, 3/8 x 1/4 in.
V32	Wire, indicating lights (used prior to 4/21/06)		

PLEASE NOTE

WHEN ORDERING PARTS PLEASE SUPPLY PUMP SERIAL NUMBER

SPL81262

PAGE 1 OF 4

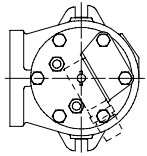

LEFT FACING AND
LEFT MOUNTING
DISCHARGE ASSEMBLIES
81262-6 (12V)
81262-9 (W/O WIRING)
81262-13 (24V)

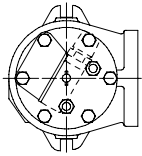

RIGHT FACING AND
RIGHT MOUNTING
DISCHARGE ASSEMBLIES
81262-7 (12V)
81262-10 (W/O WIRING)
81262-12 (W/O WIRING) (CJ)
81262-17 (24V)

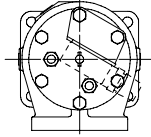

DOWN FACING
DISCHARGE ASSEMBLIES
EITHER SIDE MOUNTING
81262-8 (12V)
81262-11 (W/O WIRING)
81262-18 (24V)
81262-19 (12V & 24V)

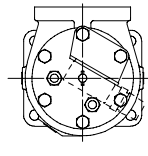

UP FACING
DISCHARGE ASSEMBLIES
EITHER SIDE MOUNTING
81262-15 (12V)
81262-16 (W/O WIRING)
81262-20 (12V & 24V)

CM, CS & CJ MODELS

EFFECTIVE 01/17/97:
WIRING TO POINT UPWARD ONLY FOR
R.H. MOUNTING CONFIGURATIONS.

CX MODELS ONLY

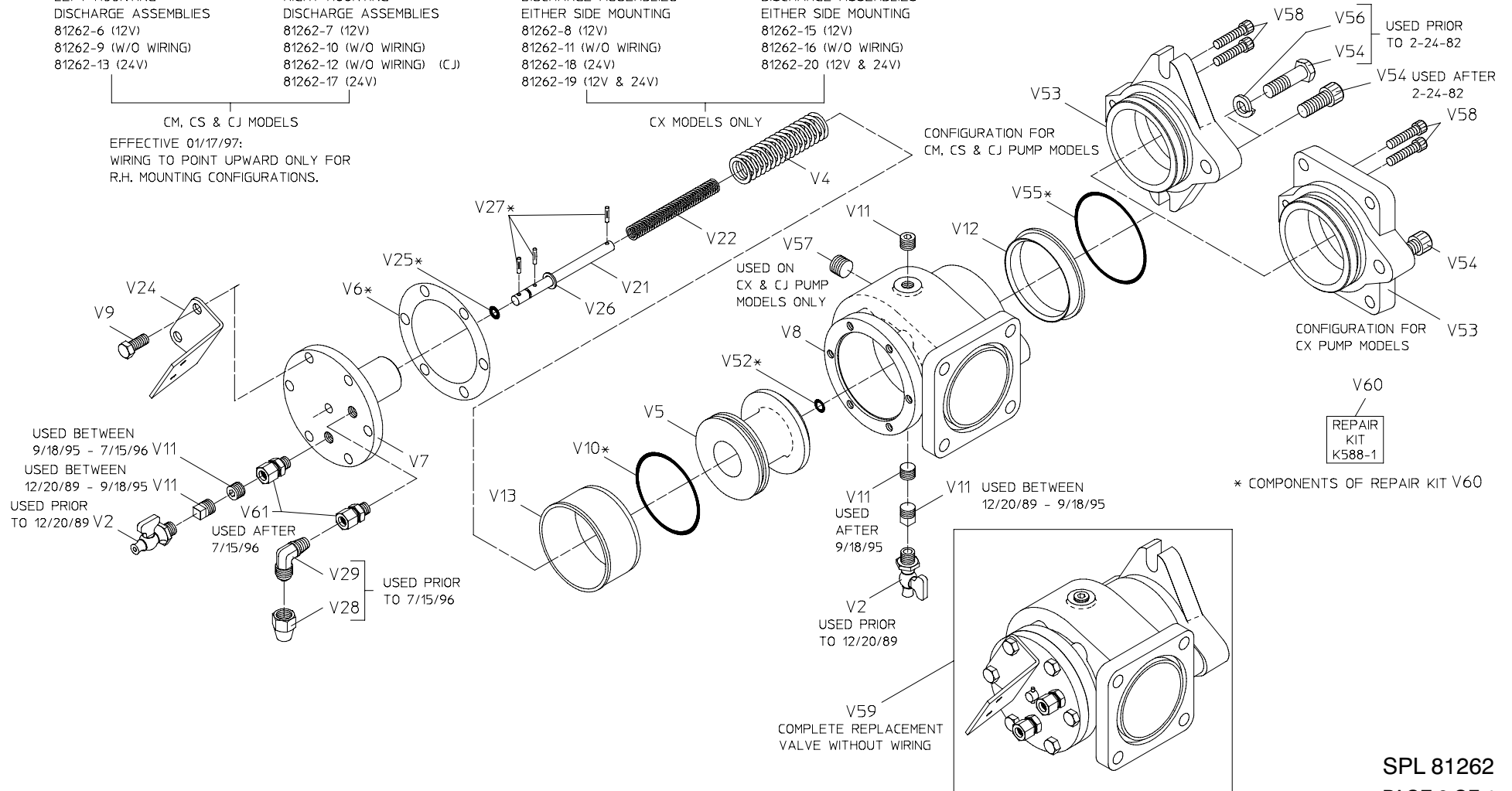

VALVE DETAILS

SEE FOLLOWING PAGES FOR WIRING DIAGRAMS

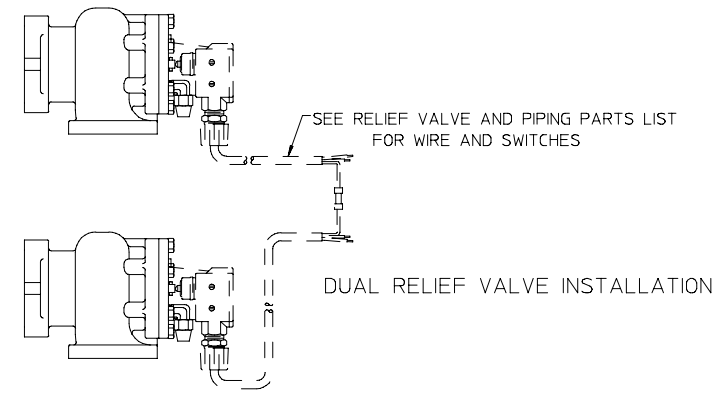
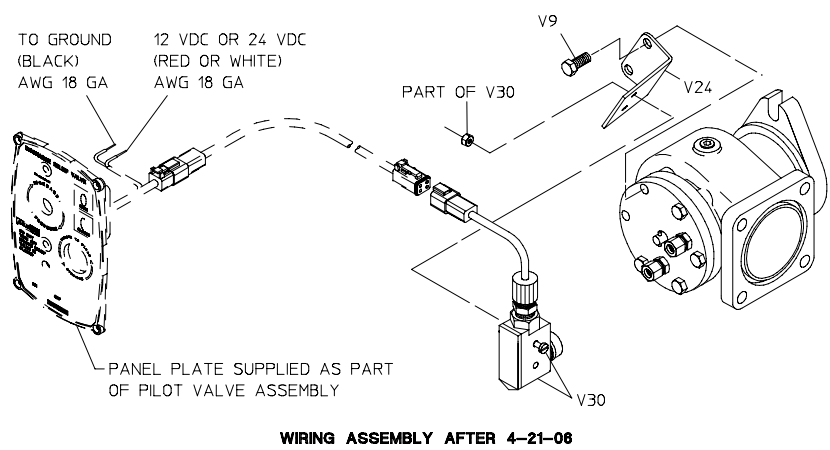
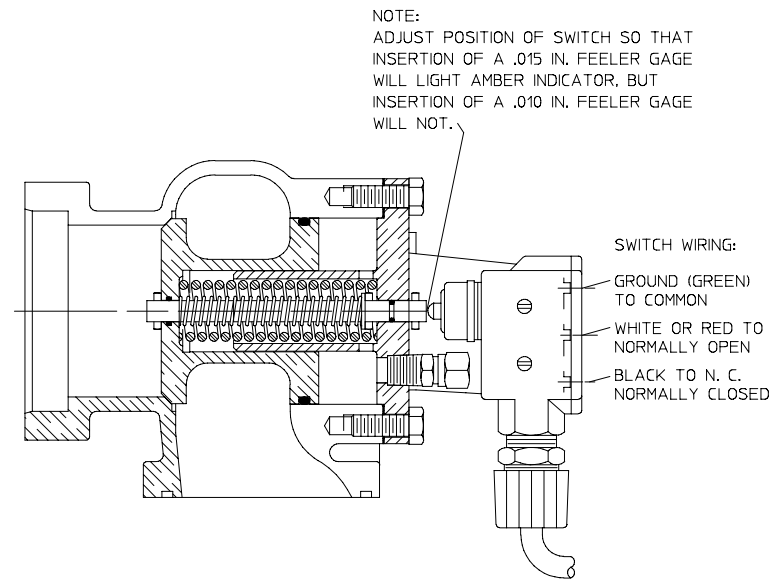
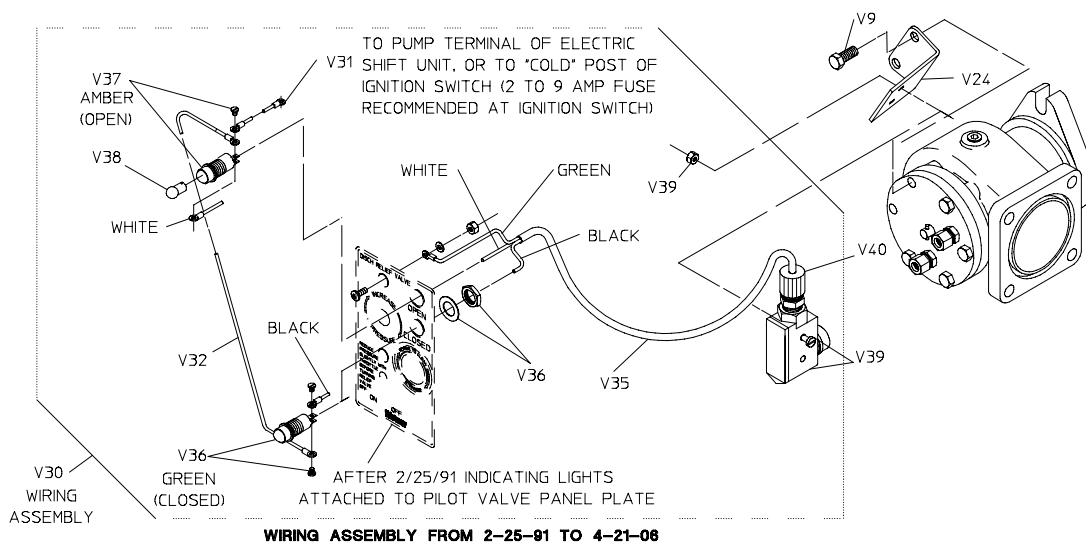

WIRING DETAILS

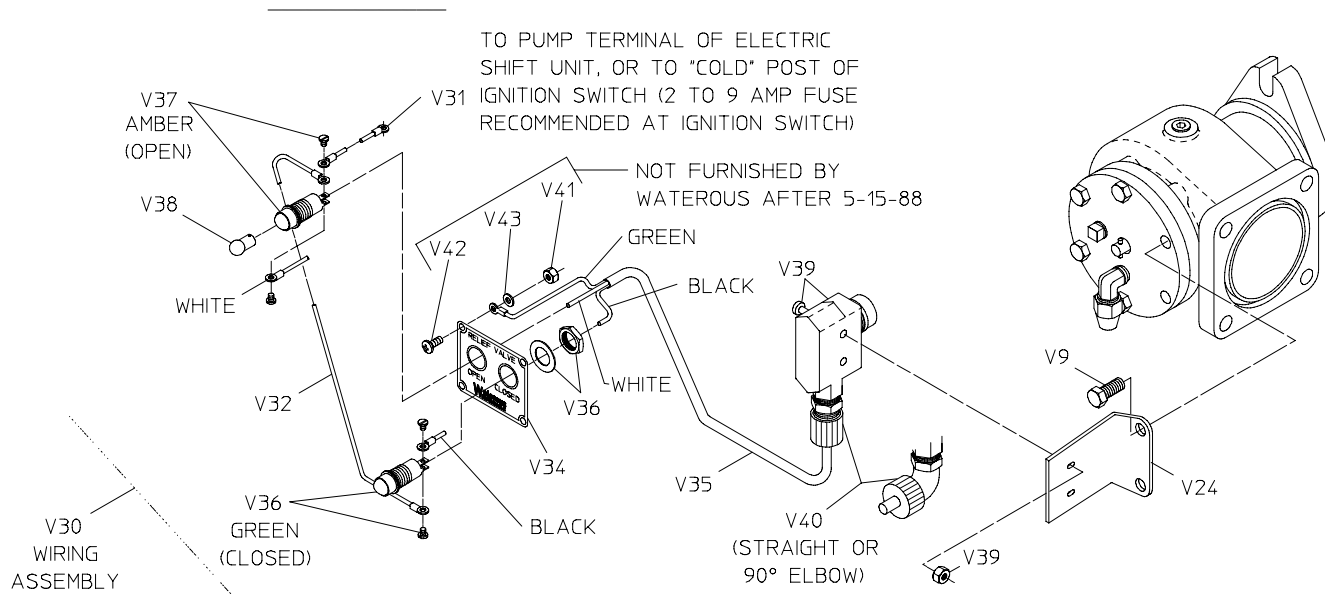

WIRING ASSEMBLY 6-1-86 TO 2-25-91

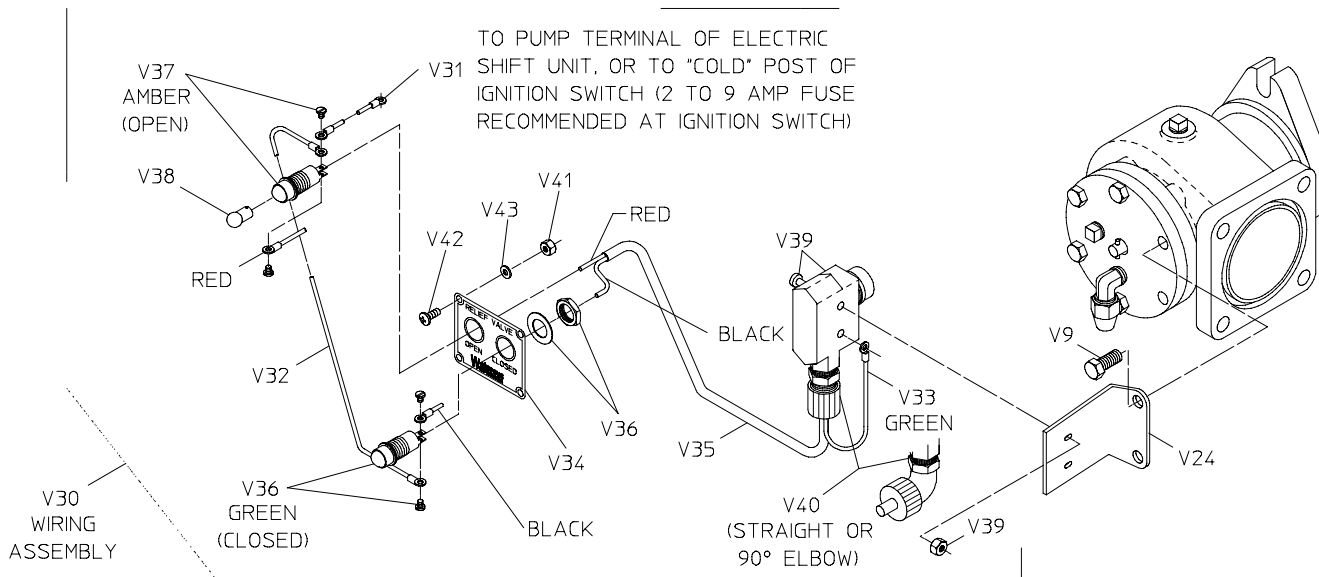

WIRING ASSEMBLY PRIOR TO 6-1-86