

Issued: 10/81
 Revised: 10/07/97



WATEROUS COMPANY
 SOUTH ST. PAUL, MINNESOTA

Relief Valve and Piping Assembly, 3 Inch

REF NO.	DESCRIPTION	REF NO.	DESCRIPTION
J1	O-ring, 3-3/8 x 3-5/8 in.	J25	Wiring harness (used prior to 8/5/86)
J2	Hex hd screw, 7/16-20 x 1-1/2 in., or 3 in. (CX and separately mounted only)	J26	Wire assembly
	Hex hd screw, 7/16-20 x 1-3/4 in., or hex screw 7/16-14 x 1-1/4 in., grade 5, standard or self-locking (CM or CS pumps only)	J27	Indicating light wire assembly
J3	Lock washer, 7/16 in.	J28	Wire assembly
J4	Hex nut, 7/16-20	J29	Panel plate (used until 2/25/91; after 2/5/91, lights are attached to pilot valve plate)
J5	Relief valve assembly, indicating or non-indicating (see separate parts list for component parts)	J30	Indicator light, green lens (closed)
J6	Hex hd screw, 1/2-20 x 6-1/2 in., or 2-1/4 in.	J31	Light bulb (12 V - light no. 1891, 24 V - light no. 313)
J7	Self-locking nut, 1/2-20	J32	Indicator light, amber lens (open)
J8	Hex hd screw, 7/16-14 x 1-1/4 in., grade 5, 1-3/4 in. or 2-1/4 in.	J33	Hex nut, No. 8-32 (not furnished by Waterous after 5/15/88)
J9	Elbow	J34	Lock washer, No. 8 (not furnished by Waterous after 5/15/88)
J10	Pipe plug, 1/4 in. bronze or steel	J35	Round hd screw, SS, No. 8-32 x 3/8 in. (not furnished by Waterous after 5/15/88)
J11	O-ring, 3-1/4 x 3-1/2 in.	J36	Connecting and sealing device (used prior to 8/5/86)
J12	Connecting pipe	J36	Sealing grip (used after 8/5/86)
J15	Tapped flange, 3 NPT, 4-bolt	J37	Relief valve fitting
J16	Tapped flange, 3 NPT, 2-bolt	J38	Extension, relief valve (inverted pumps only)
J17	Wire assembly (includes items J23 thru J36 prior to 8/5/86, includes items J23, J26 & J36 after 8/5/86) dual relief valves only	J39	Extension, relief valve (with heater jacket only)
J23	Actuator switch	J40	Stud, 7/16-14 x 2-3/4 in. (used prior to 5/10/90)
J24	Switch ground wire assembly (prior to 8/5/86)	J56	Hex nut, 1/2-20
		J59	Victaulic fitting, Inlet
		J60	Victaulic fitting, Outlet
		J61	Hex hd screw, 7/16-14 x 2-1/4
		J62	Hex hd screw, 7/16-20 x 2-3/4

PLEASE NOTE

WHEN ORDERING PARTS PLEASE SUPPLY PUMP SERIAL NUMBER

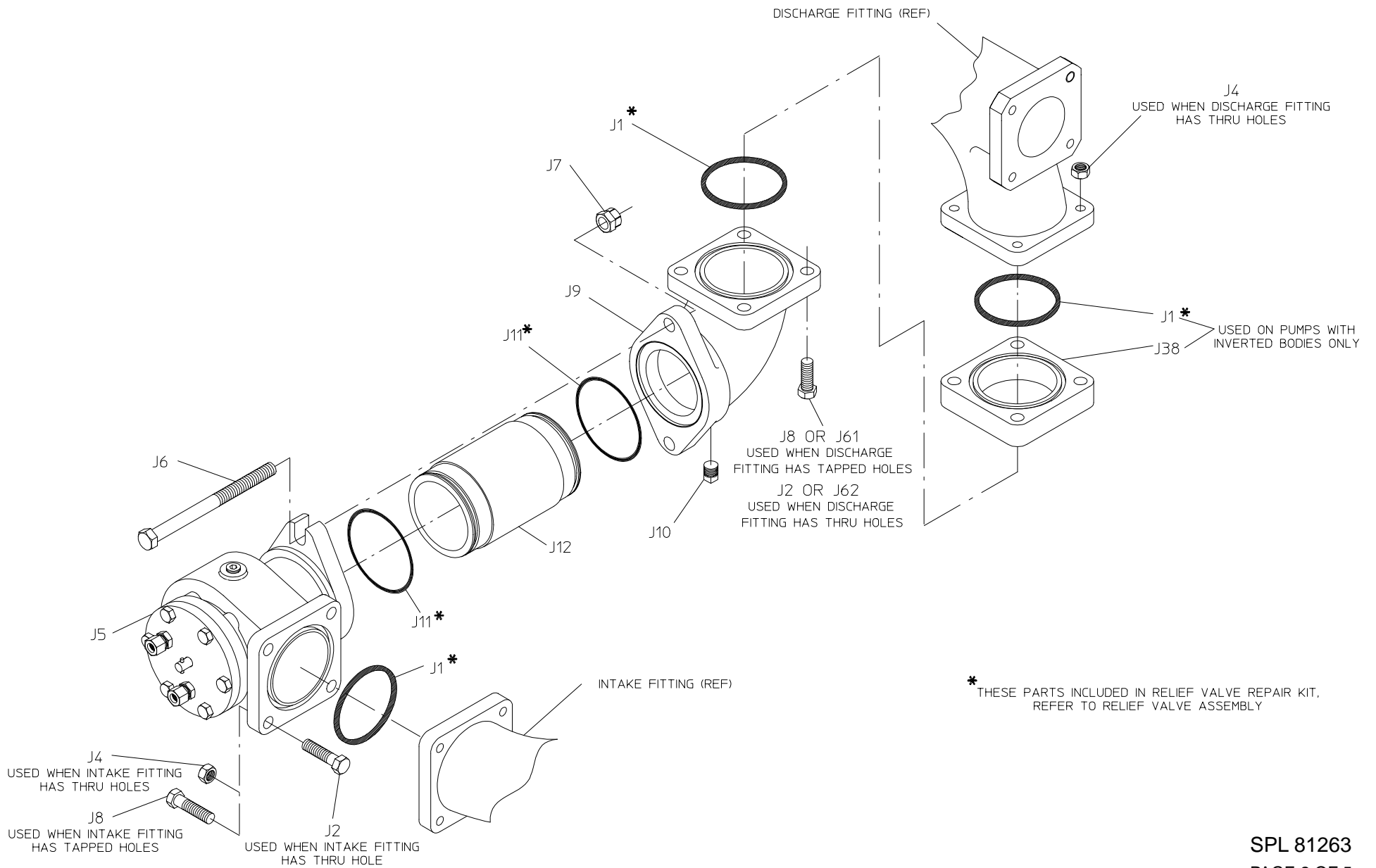

CM & CS PUMP MOUNTED VALVE

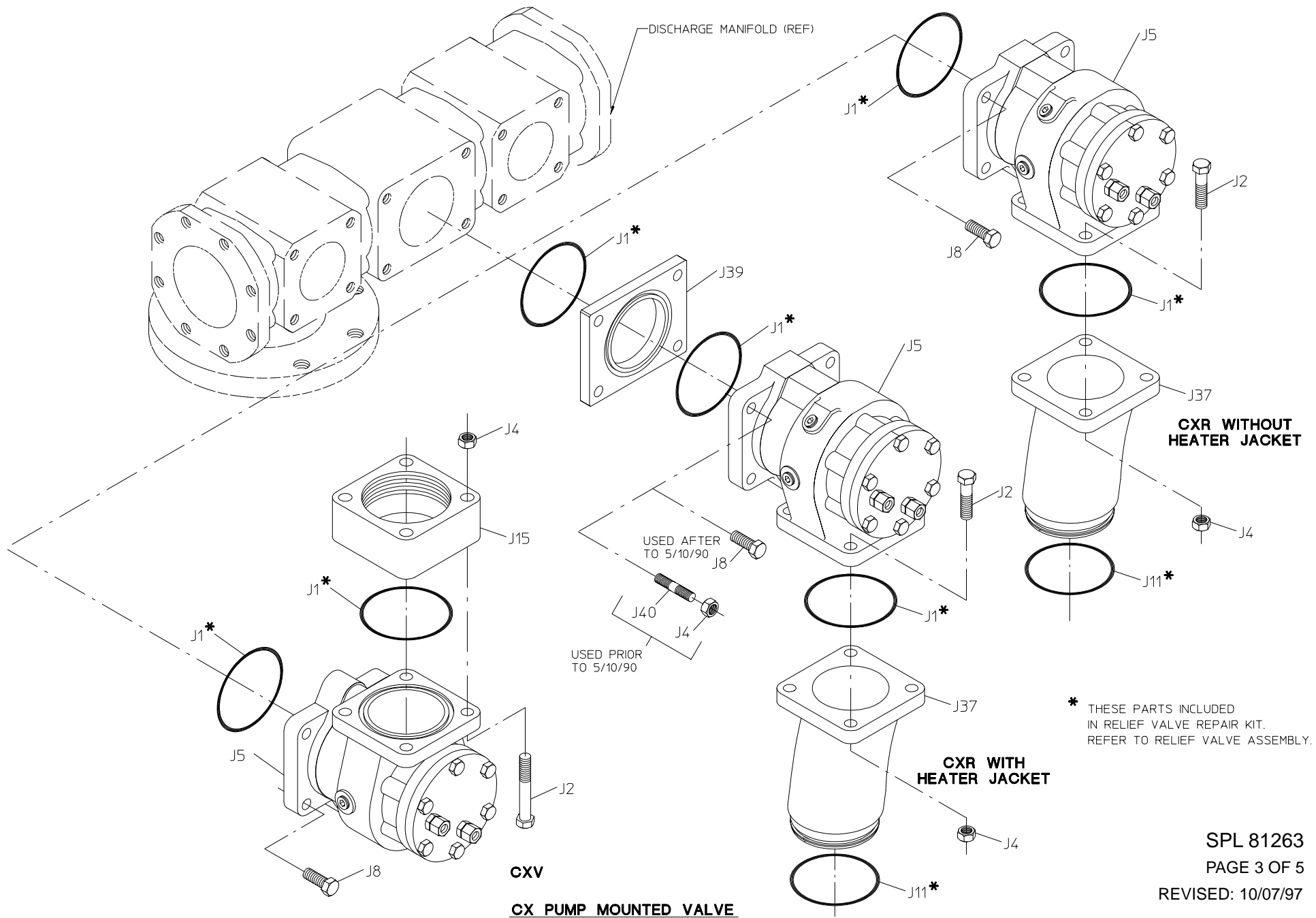

SPL 81263

PAGE 3 OF 5

REVISED: 10/07/97

* THESE PARTS INCLUDED IN
RELIEF VALVE REPAIR KIT.
REFER TO RELIEF VALVE ASS'Y

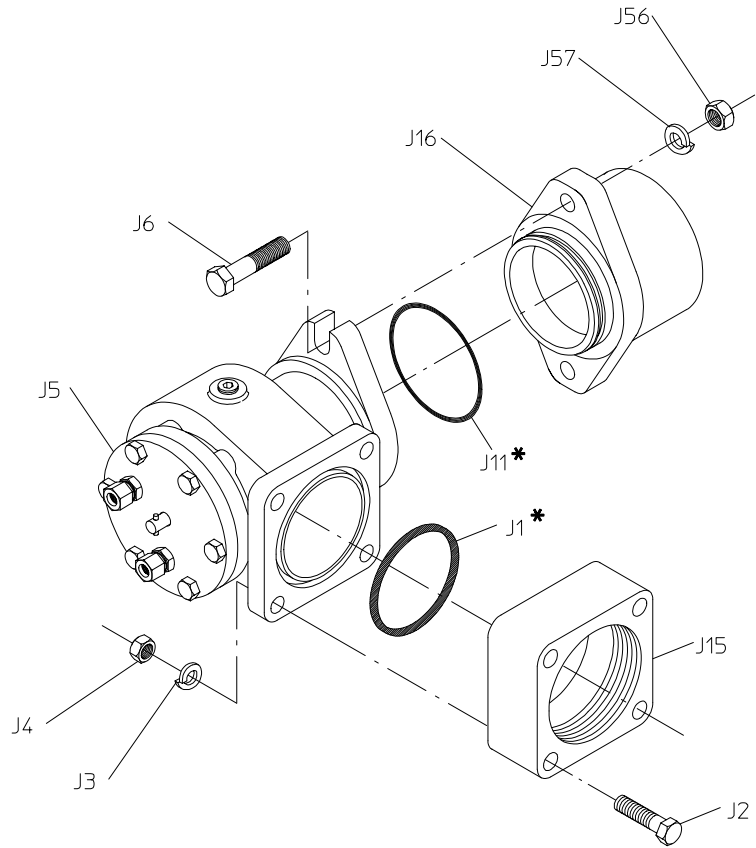

**SEPARATELY MOUNTED VALVE
WITH TAPPED FITTINGS**

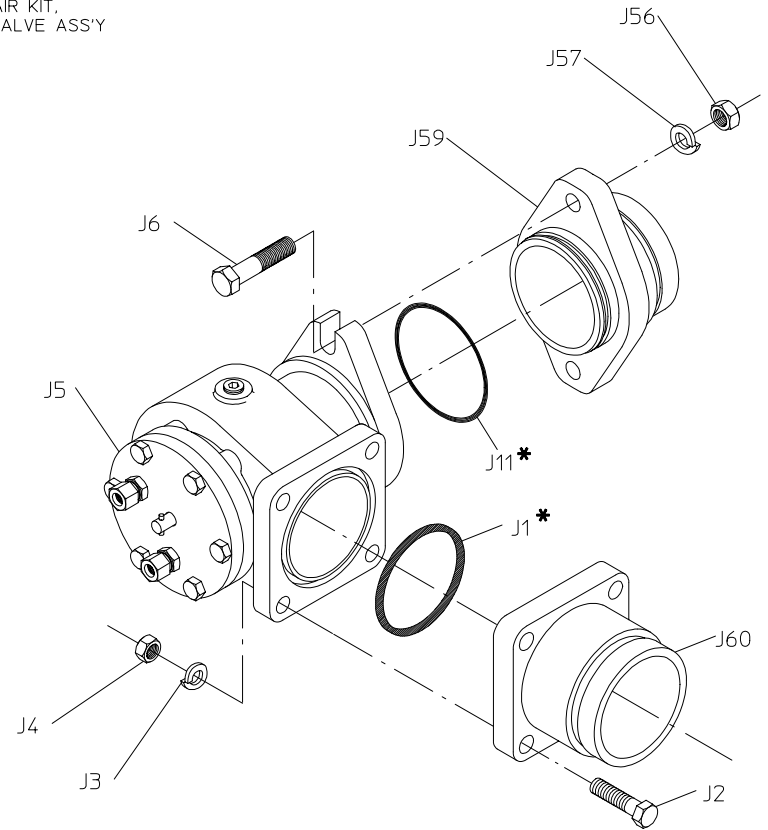

**SEPARATELY MOUNTED VALVE
WITH VICTAULIC FITTINGS**

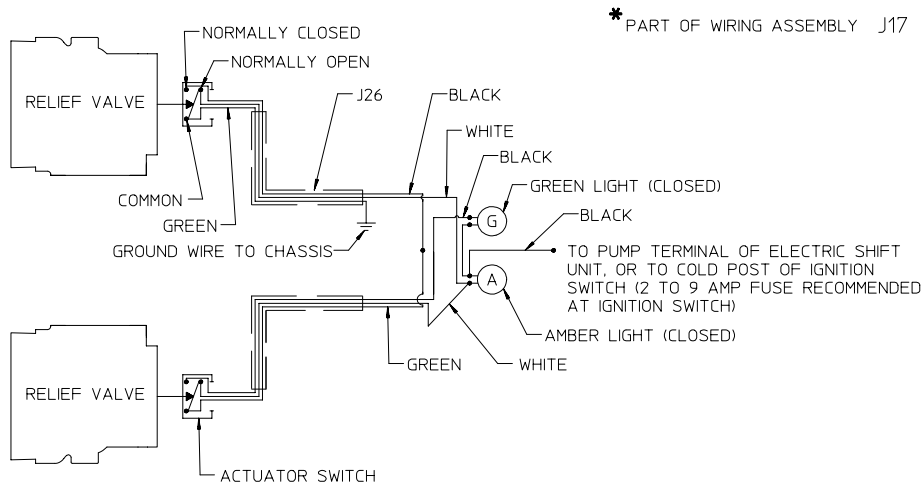
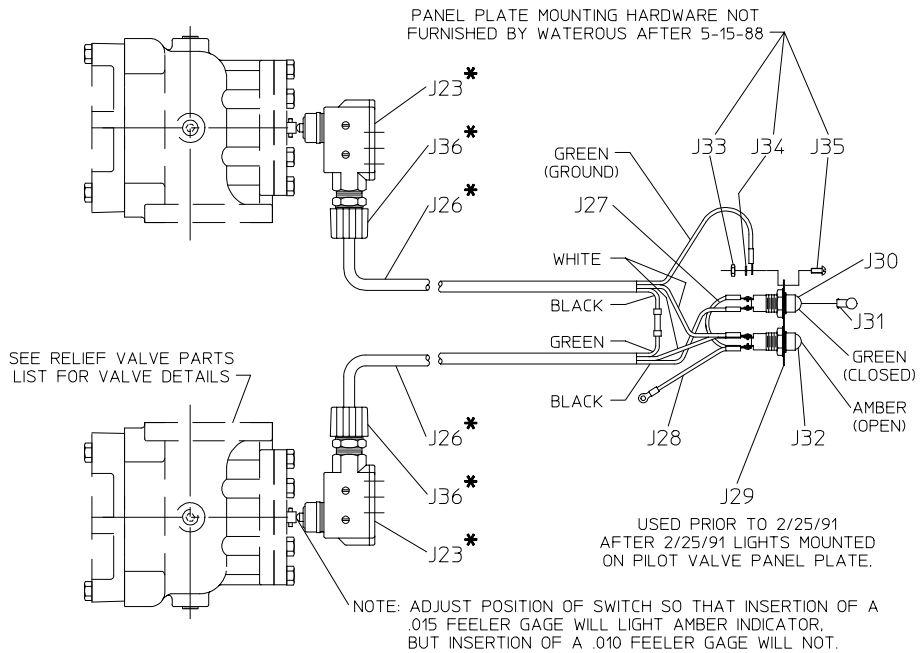

ASSEMBLY AFTER 8-5-86

DUAL RELIEF VALVE WIRING

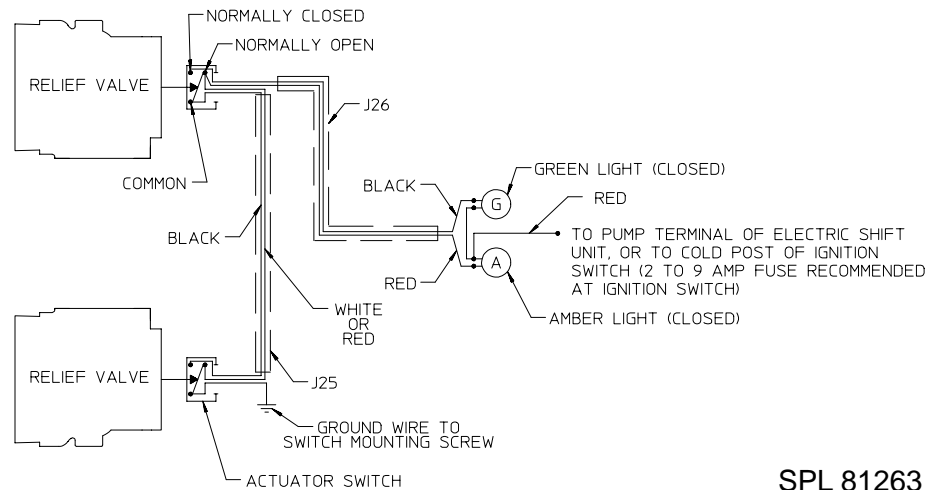
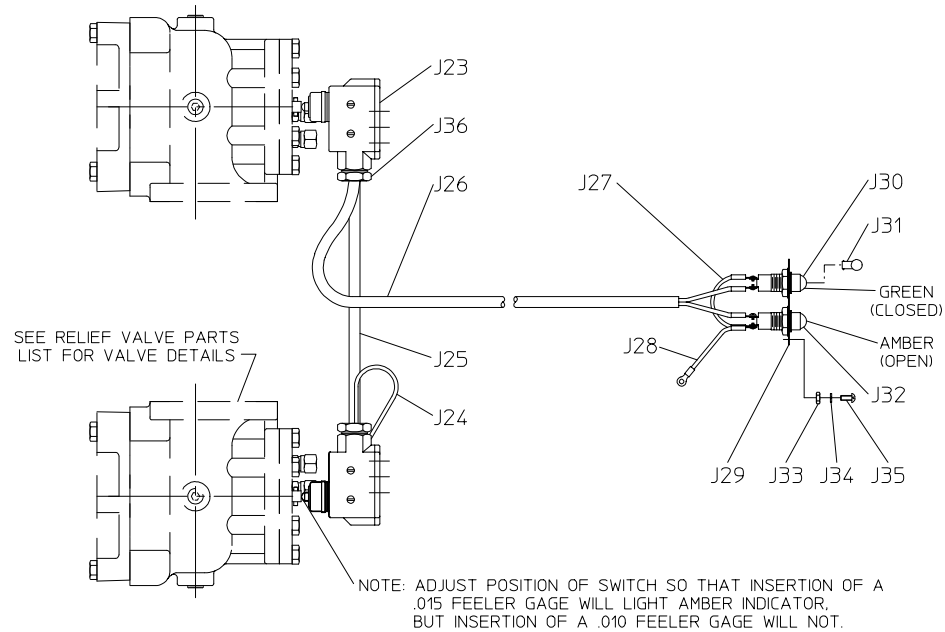

ASSEMBLY PRIOR TO 8-5-86

SPL 81263

PAGE 5 OF 5

REVISED: 10/07/97