

Issued: 1/19/83
Revised: 06/02/04

W A T E R O U S

WATEROUS COMPANY
SOUTH ST. PAUL, MINNESOTA

Y SERIES CHAIN DRIVE TRANSMISSION

REF NO.	DESCRIPTION	REF NO.	DESCRIPTION
T1	Ball bearing, coupling shaft	T27	Breather
T2	Bearing spacer, coupling shaft	T28	Chain case assembly (supplied as assembly only consisting of midsection and bottom section)
T3	Ball bearing, drive shaft pilot	T29	Bearing spacer, impeller shaft
T4	Shift collar	T30	Shim, bearing housing, 0.005 (blue) and 0.010 (brown) in. thick
T5	Drive sprocket	T31	Pump support housing
T6	Needle bearing	T32	Bearing lock washer
T7	Drive shaft spacer	T33	Bearing lock nut
T8	Hex hd screw w/thread sealant, 3/8-16 x 1-1/4 in.	T34	Oil circulating pump
T9	Lock washer, 3/8 in.	T37	Pivot pin
T10	Drive gear or pulse generator, tachometer	T38	Locking arm assembly
T11	Drive shaft housing	T39	O-ring
T12	Cotter pin, SS, 1/8 x 1-3/4 in.	T40	Shifter shoe
T13	Drive shaft	T41	Shim, coupling shaft housing, 0.005 (blue), 0.007 (natural), and 0.010 (brown) in. thick
T14	Oil seal sleeve	T42	Coupling shaft housing
T15	Ball bearing, drive shaft	T43	Shaft nut
T17	Drive shaft housing gasket	T44	Coupling shaft
T18	Drive chain	T45	Oil seal
T19	Oil seal	T46	Shift shaft
T22	Lock washer, 5/16 in.	T47	Sector gear
T23	Oil seal housing	T48	Gear sector spacer
T24	Oil seal housing gasket		
T25	Ball bearing, impeller shaft		
T26	Driven sprocket		

PLEASE NOTE

WHEN ORDERING PARTS PLEASE SUPPLY PUMP SERIAL NUMBER

SPL81331
PAGE 1 OF 10

W A T E R O U S

WATEROUS COMPANY

SOUTH ST. PAUL, MINNESOTA

Y SERIES CHAIN DRIVE TRANSMISSION

REF NO.	DESCRIPTION	REF NO.	DESCRIPTION
T49	O-ring	T73	Sq hd pipe plug, 3/4 in.
T50	Shift shaft bushing	T75	Shift shoe (included with fork T80) Available individually for repairs
T51	Spirol pin, SS, 5/16 x 1-3/8 in.	T76	Shifter shoe stud (included with fork T80) Available individually for repairs
T52	Hex hd screw, 1/2-13 x 1-1/4 in.	T80	Shift fork (supplied with shifter shoes T75, and shifter shoe studs T76)
T53	Lock washer, 1/2 in.	T83	Pin set, connecting (chain repairs)
T54	Spirol pin, heavy duty, 3/8 x 1-3/4 in. (prior to 9/25/98 on pneumatic shift, prior to 12/20/02 on manual or electric shift.)	T85	Drain pipe
T55	Shift cover	T86	Adjusting screw
T56	Shift cover gasket	T87	Adjusting screw retainer
T57	Street elbow, 90°, 1/2 in.	T88	Driven gear bushing, tachometer
T58	Magnetic drain plug, 3/4 in.	T89	Driven gear, tachometer
T59	Spring housing, shift arm	T90	Driven gear sleeve, tachometer
T60	Spirol pin, SS, 1/4 x 1-1/4 in.	T92	Driven gear cap, tachometer (furnished prior to 2/1/89)
T61	Shift arm spring	T93	Hex hd screw, 1/2-20 x 1-3/4 in.
T62	Shift arm	T94	Washer, plain, 1-1/4 in.
T64	Hose, oil pump to spray tube	T95	Bearing spacer, impeller shaft
T65	Chain case cap	T96	Gasket, oil pump
T66	Straight adapter union, 1/2 in.	T97	Hex hd screw, 5/16-18 x 3-1/4 in.
T67	Hose, sump to oil pump	T98	Sq hd pipe plug, 1/2 in.
T68	Hex hd screw, 1/2-20, 2-1/4 or 4-1/4 in.	T99	Spacer, cap
T69	Hex nut, 1/2-20	T100	Spacer, cap (YC only)
T70	Hex hd screw, 1/2-13, 1-1/2 or 3-1/2 in.		
T72	Hex hd screw, 1/2-13 x 1 in., Grade 5 (with thread sealant)		

SPL 81331

PAGE 2 OF 10

REV: 06/02/04

WATEROUS

WATEROUS COMPANY

SOUTH ST. PAUL, MINNESOTA

Y SERIES CHAIN DRIVE TRANSMISSION

REF NO.	DESCRIPTION	REF NO.	DESCRIPTION
T101	Nipple, pipe, 1/2 x 2-1/2 in.	T181	O-ring
T102	Tee, pipe, 1/2 in.	T182	O-ring
T103	Pin, dowel, 1/2 x 1-1/2 in. (YB) or 3 in. (YC)	T183	Ball bearing, double row
T104	Spacer, tachometer gear	T184	Ball bearing, double row
T105	Ring, retaining	T186	Hex hd screw, 1/2-13 x 1-1/4 in., Grade 5 with thread sealant
T106	Hex hd screw, 1/2-20 x 2 in.	T187	Oil seal, 3-1/2 x 4-3/8 in.
T108	Spirol pin, heavy duty, SS, 1/16 x 1/4 in. (Chain repairs)	T190	Bearing sleeve
T109	Stud, 1/2-13 x 1/2-20 (YC only), 4-1/4 in.	T191	Stud, 1/2-20 x 1/2-20 x 2-3/4 in. (YD)
T110	Stud, 1/2-20 x 1/2-20 (YC only), 4-3/4 in.	T230	Drive shaft spacer
T112	Lower shift shaft bushing	T231	Oil seal, 2-1/2 in. x 3-1/2 in.
T131	Pin, dowel, 3/8 x 1 in. (part of T28)	T237	Shoulder screw, 3/8 x 1-3/4 in. (after 9/25/98 on pneumatic shift, after 12/20/02 on manual or electric shift.)
T132	Oil strainer	T238	Lock nut, 5/16-18 in. (after 9/25/98 on pneumatic shift, after 12/20/02 on manual or electric shift.)
T133	Hex hd screw, 3/8-16 x 1 in.	T239	Spacer, tachometer
T134	Sight plug	T240	Hex hd screw, 1/2-20 x 2-1/2 in.
T141	Gasket and shim kit consists of: T17, T24, T30, T41, T43, T56, T94 and T96	T241	Hex hd screw with thread sealant, 3/8-16 x 1-1/2 in.
T173	Shift lever, actuating		
T174	Hex hd screw, 1/2-13 x 1-3/4 in.		
T180	Magnetic pickup		

SPL 81331

PAGE 3 OF 10

REV: 06/02/04

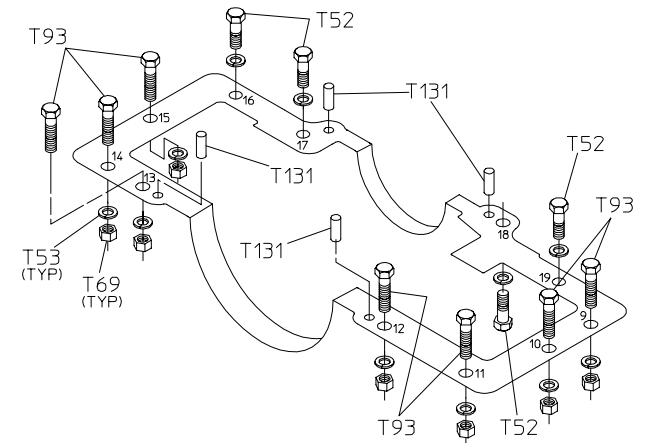
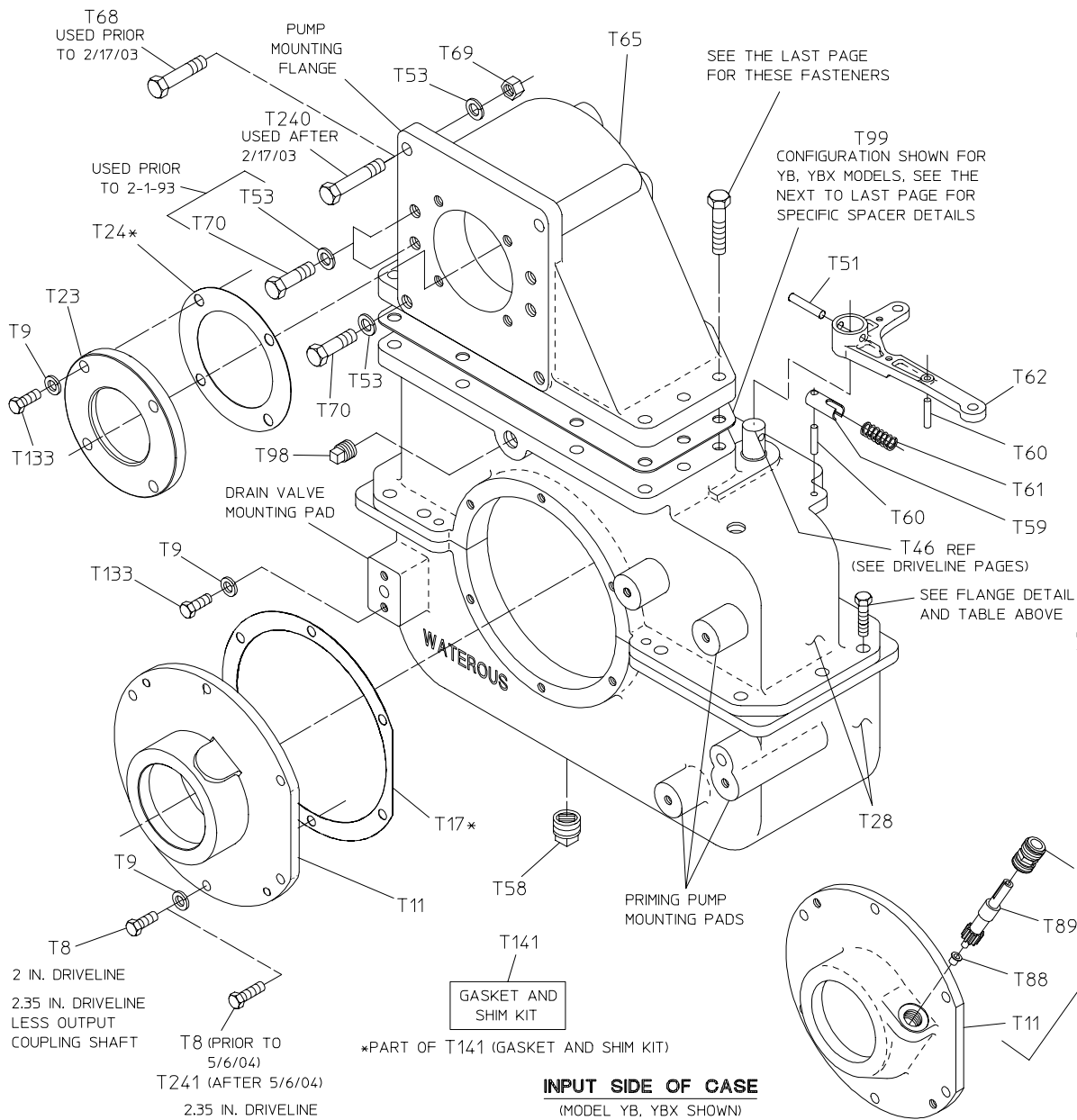

FASTENER TYPE AND LENGTH			
HOLE NO.	TYPE	THREAD	LENGTH
9 TO 15	HEX HD SCREW	1/2-20	1-3/4
16 TO 19	HEX HD SCREW	1/2-13	1-1/4

OPTIONAL ELECTRONIC TACHOMETER

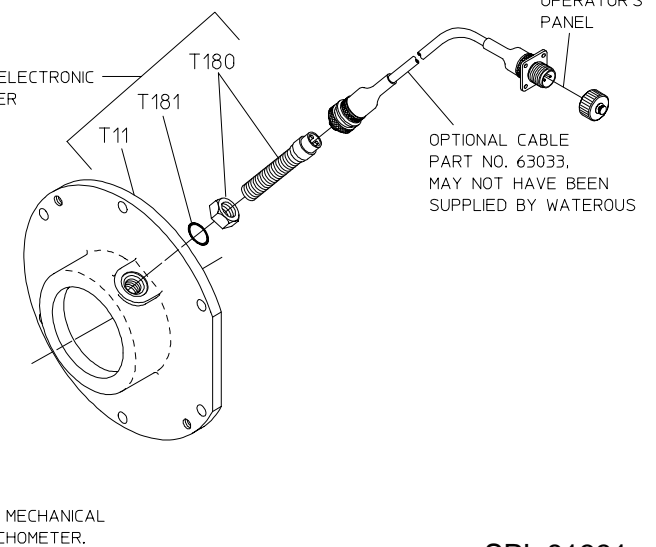

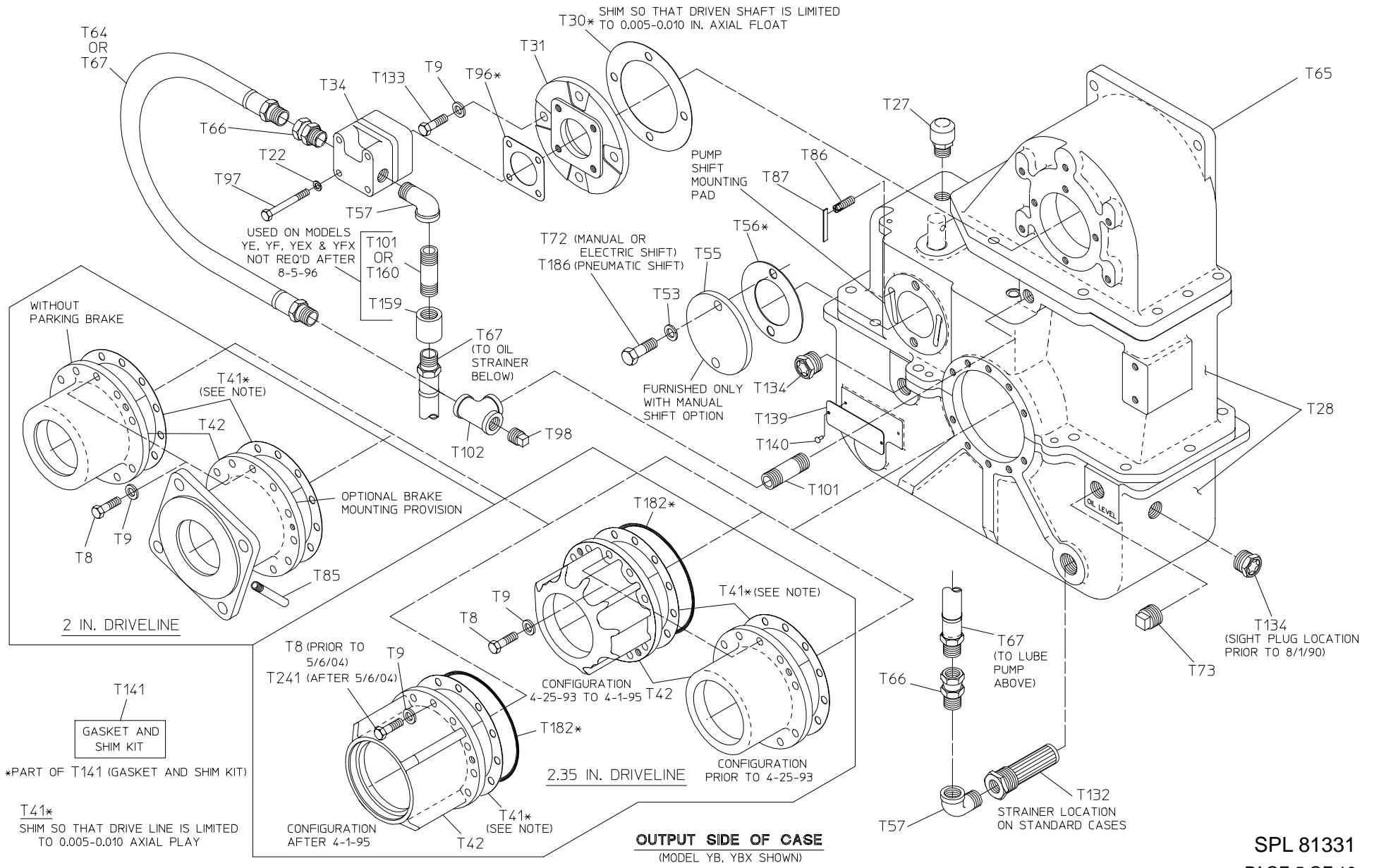

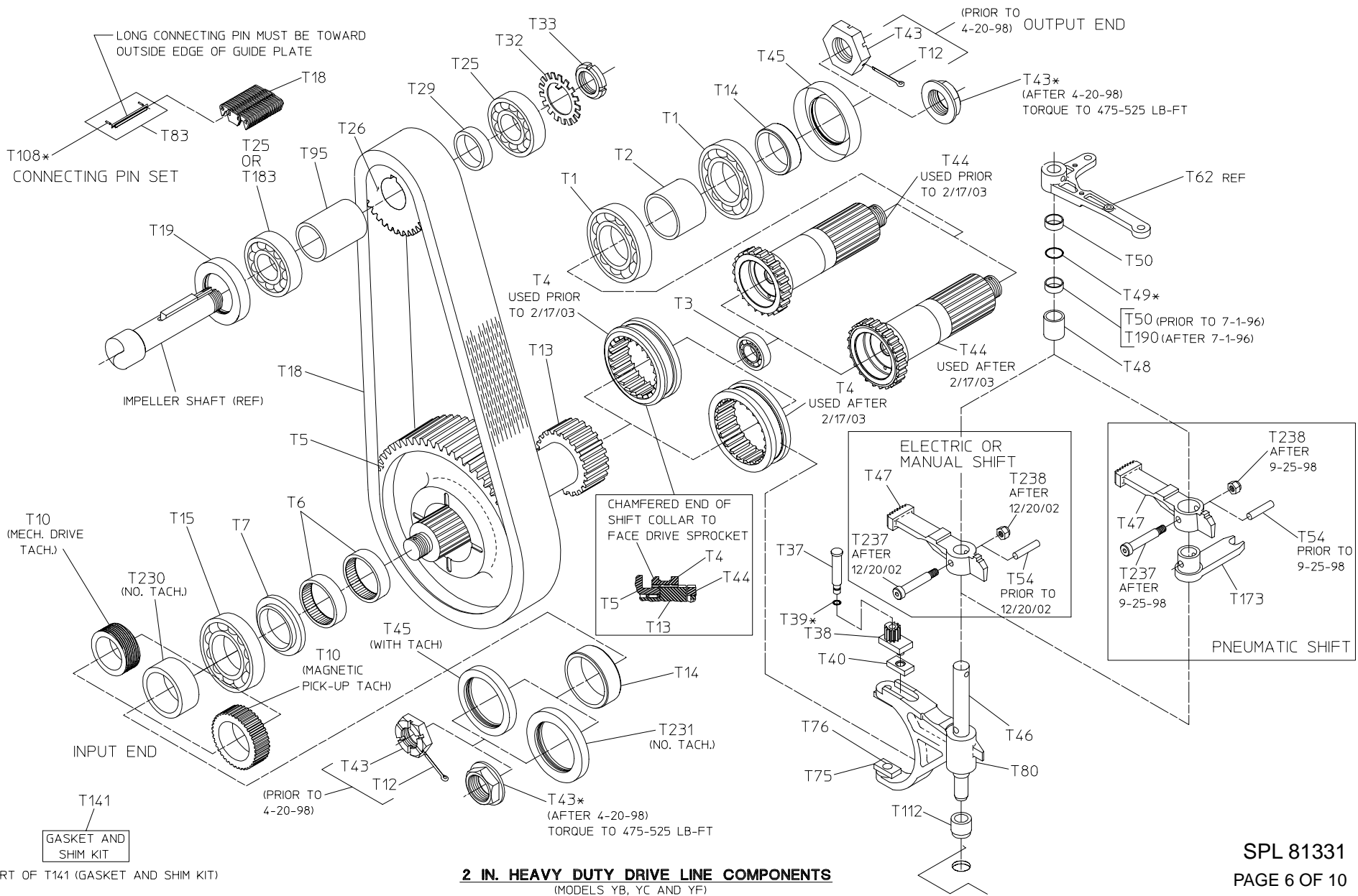

LONG CONNECTING PIN MUST BE TOWARD
OUTSIDE EDGE OF GUIDE PLATE

T108*
T83
T18

CONNECTING PIN SET

SERIES	YOKE PART NO.	CROSS & BRG KIT NO.
1710	V2837	V2839
1810	V2838	V2840

OPTIONAL END YOKE AND
CROSS & BEARING KITS
MAY NOT HAVE BEEN SUPPLIED
BY WATEROUS

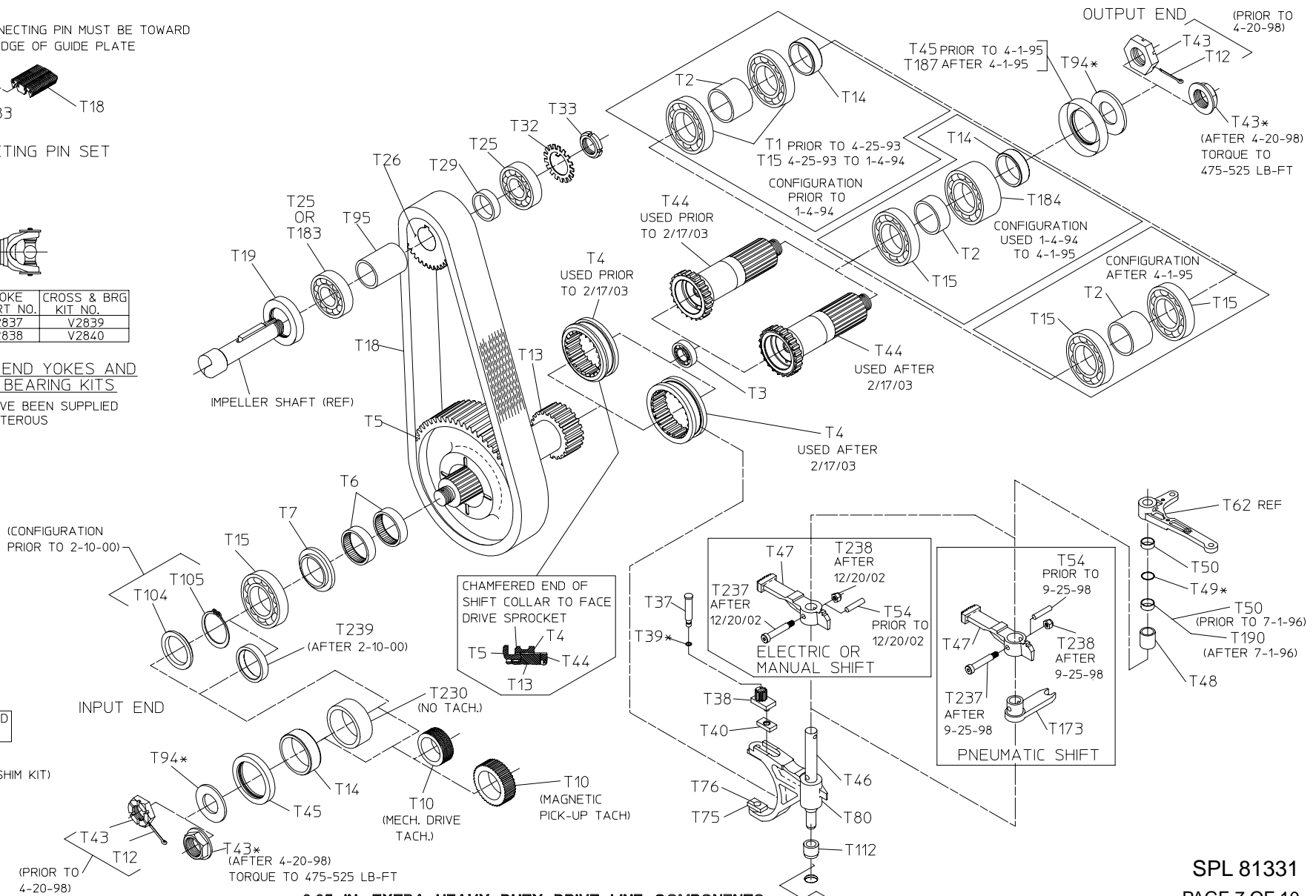

2.35 IN. EXTRA HEAVY DUTY DRIVE LINE COMPONENTS
(MODELS YBX, YCX AND YFX)

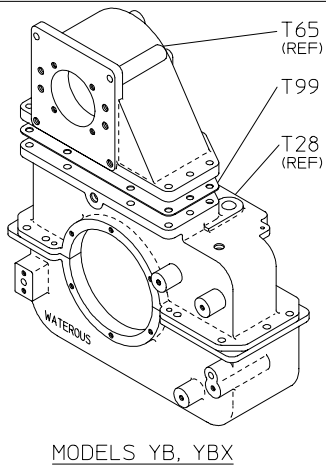

MODELS YB, YBX

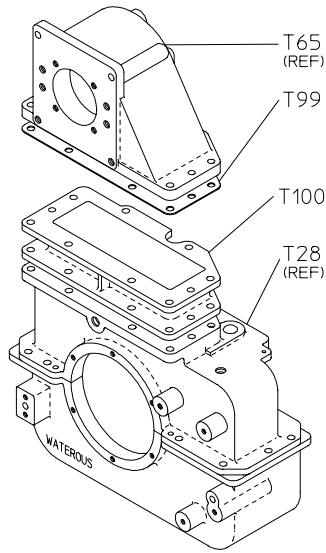

MODELS YD, YDX

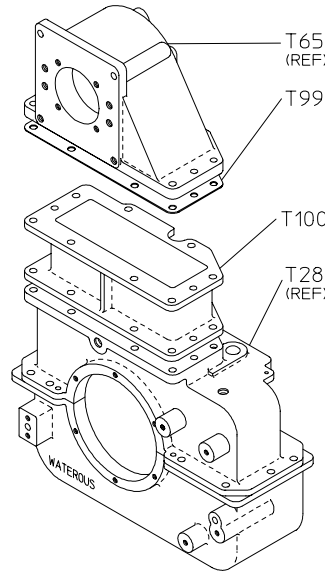

MODELS YE, YEX

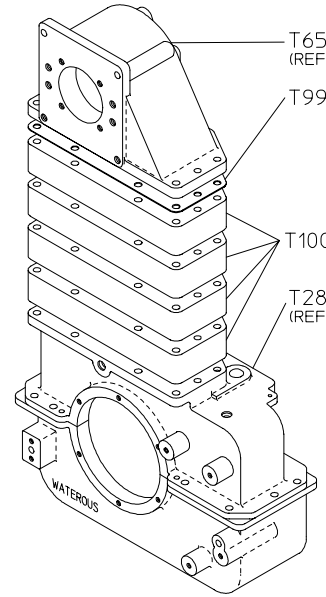

MODELS YF, YFX
(PRIOR TO 8-5-96)

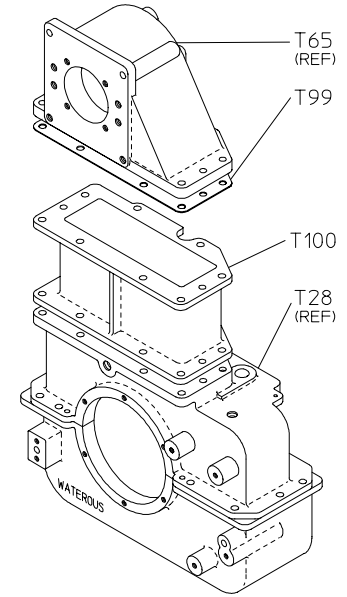

MODELS YF, YFX
(AFTER 8-5-96)

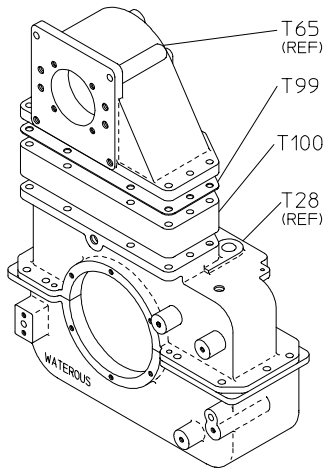

MODELS YC, YCX

RATIOS	MODELS YB, YBX	MODELS YC, YCX		MODELS YD, YDX		MODELS YE, YEX		MODELS YF, YFX (PRIOR TO 8-5-96)		MODELS YF, YFX (AFTER 8-5-96)	
	T99	T99	T100	T99	T100	T99	T100	T99	T100	T99	T100
1.14	2	6	1	4	1	3	1	*	*	2	1
1.27	0	0	1	3	1	2	1	*	*	1	1
1.41	0	3	1	3	1	2	1	*	*	1	1
1.48	4	5	1	3	1	1	1	*	*	1	1
1.58	0	2	1	2	1	1	1	*	*	0	1
1.69	4	0	1	1	1	4	1	*	*	4	1
1.79	2	1	1	1	1	3	1	*	*	2	1
1.88	2	0	1	1	1	3	1	2	4	2	1
1.97	2	1	1	2	1	2	1	*	*	3	1
2.03	0	2	1	2	1	1	1	*	*	2	1
2.27	0	3	1	0	1	0	1	0	4	0	1
2.46	3	3	1	1	1	3	1	*	*	3	1
2.73	3	1	1	3	1	2	1	*	*	2	1

*NOTE: THESE RATIOS ARE NOT AS YET AVAILABLE FOR THESE MODELS.

SPACERS BETWEEN CAP (T65) AND CASE (T28)
(SEE NEXT 2 PAGES FOR HARDWARE DETAILS)

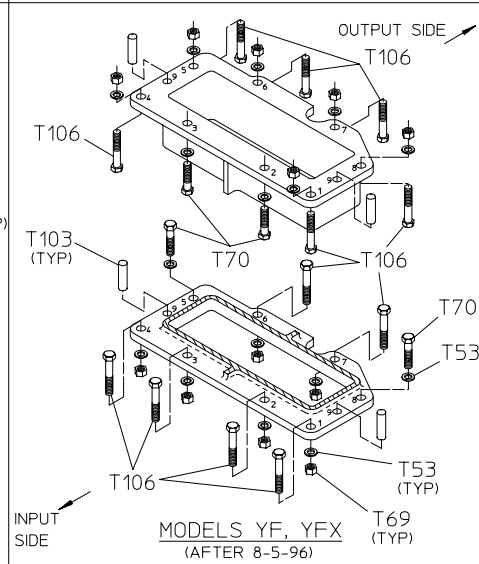
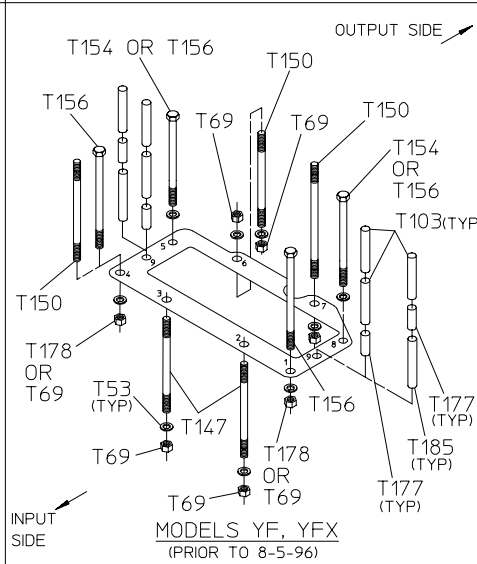
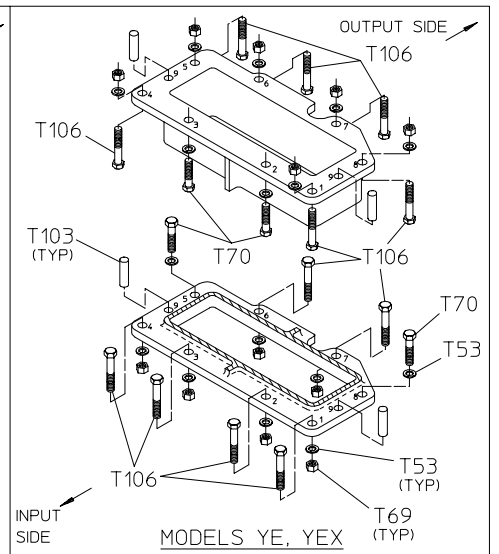
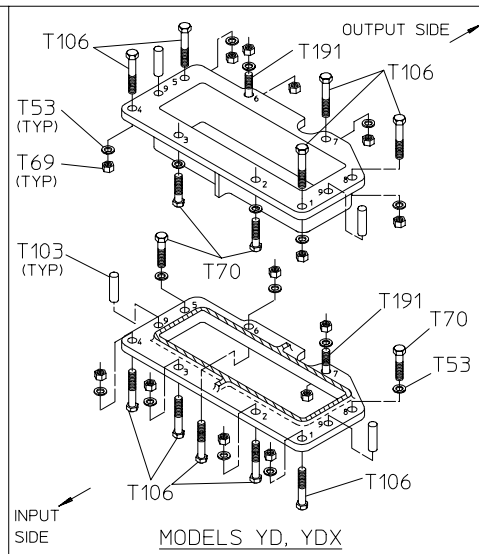
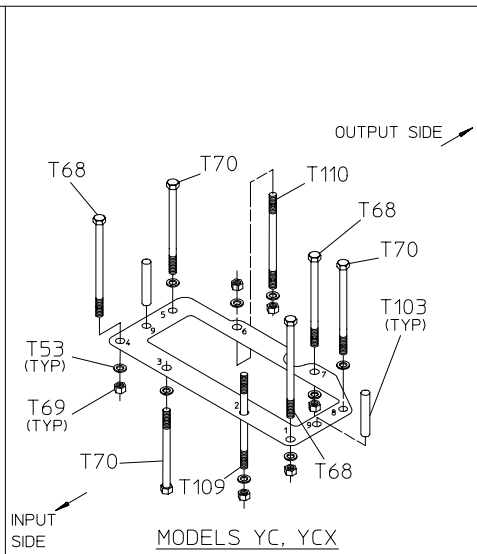
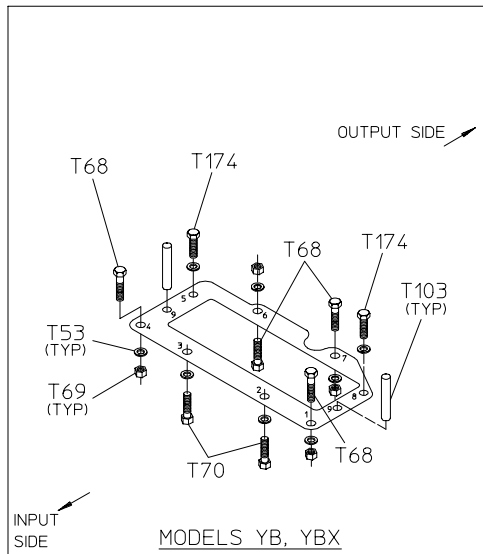

REF. NO.	TYPE	THREAD	LENGTH (MODEL)						YF, YFX (PRIOR TO 8-5-96)	YF, YFX (AFTER 8-5-96)
			YB, YBX	YC, YCX	YD, YDX	YE, YEX				
T53	LOCKWASHER	1/2	---	---	---	---	---	---	---	
T68	HEX HD SCREW	1/2-20	2-1/4	4-1/4	---	---	---	---	---	
T69	HEX NUT	1/2-20	---	---	---	---	---	---	---	
T70	HEX HD SCREW	1/2-13	1-1/2	3-1/2	1-1/2	1-1/2	---	---	1-1/2	
T103	DOWEL PIN, 1/2	---	1-1/2	3	1-1/2	1-1/2	3	---	1-1/2	
T106	HEX HD SCREW	1/2-20	---	---	2	2	---	---	2	
T109	STUD	1/2-13 x 1/2-20	---	4-1/4	---	---	---	---	---	
T110	STUD	1/2-20 x 1/2-20	---	4-3/4	---	---	---	---	---	
T147	STUD	1/2-13 x 1/2-20	---	---	---	---	8-3/4	---	---	
T150	STUD	1/2-20 x 1/2-20	---	---	---	---	9-1/2	---	---	
T154	HEX HD SCREW	1/2-13	---	---	---	---	8	---	---	
T156	HEX HD SCREW	1/2-13	---	---	---	---	9	---	---	
T174	HEX HD SCREW	1/2-13	---	---	---	---	8-3/4	---	---	
T177	DOWEL PIN, 1/2	---	---	---	---	---	1-3/4	---	---	
T185	DOWEL PIN, 1/2	---	---	---	---	---	3-1/2	---	---	
T191	STUD	1/2-20 x 1/2-20	---	---	2-3/4	---	---	---	---	

HOLE NO.	MODELS YB, YBX	MODELS YC, YCX	MODELS YD, YDX		MODELS YE, YEX		MODELS YF, YFX (PRIOR TO 8-5-96)		MODELS YF, YFX (AFTER 8-5-96)	
	ALL RATIOS	ALL RATIOS	ALL RATIOS		ALL RATIOS		1.88	2.27	ALL RATIOS	
			UPPER	LOWER	UPPER	LOWER			UPPER	LOWER
1	T68	T68	T106	T106	T106	T106	T156	T150	T106	T106
2	T70	T109	T70	T106	T70	T106	T147	T147	T70	T106
3	T70	T70	T70	T106	T70	T106	T147	T147	T70	T106
4	T68	T68	T106	T106	T106	T106	T156	T150	T106	T106
5	T174	T70	T106	T70	T106	T70	T154	T156	T106	T70
6	T68	T110	T191	T106	T106	T106	T150	T150	T106	T106
7	T68	T68	T106	T191	T106	T106	T150	T150	T106	T106
8	T174	T70	T106	T70	T106	T70	T154	T156	T106	T70
9 (2) LOCATIONS	T103	T103	T103	T103	T103	T103	T103 (2) T177 (1)	T103(1) T177(1) T185(1)	T103	T103

FLANGE HARDWARE BETWEEN CAP (T65) AND CASE (T28)