



Document Number <b>SPL81607</b>	Issue Date <b>05/88</b>	Rev. Date <b>03/23/06</b>
------------------------------------	----------------------------	------------------------------

**CM Series Impeller Shaft Assembly for  
Waterous Two and Three Stage Fire Pumps  
Service Parts List**

Pump Type	Pump and Transmission Model	Drive	Shaft		See Page for Diagram		
			Type	Spline	Packing	Mechanical Seal	
Two Stage	CMWB, CMWK, CMYB thru CMYF, CMUYB thru CMUYF, CMK, CMUK	Rear	Separable	35 Tooth	4	5	
				14 Tooth	6	7	
	CMBE, CMK1, CMUK	Front or Rear	One-Piece	N/A	8	-	
	CMD, CMUD	w/Tach on Drive End	Front	One-Piece	N/A	9	11
		w/o Tach	Rear	One-Piece	N/A	14	10
CMY/CPK	Rear	Separable	35 Tooth	15	16		
Three Stage	CMHWB, MCHWK, CMHK, CMHM, CMHYB thru CMHYF, CMUHYB thru CMUHYF	Rear	One-Piece	N/A	12	-	
	CMHD, CMUHD	Front	One-Piece	N/A	13	-	

## CM Series Impeller Shaft Assembly for Waterous Two and Three Stage Fire Pumps

REF NO.	DESCRIPTION
S1	Ball bearing
S3	Seal chamber cover
S3	Packing gland (2 halves)
S8	Split lock ring
S11	Flexible graphite packing (Grafoil®)
S14	Outboard bearing housing
S15	Stuffing box end assembly
S16	Interstage seal
S17	Wear ring (std, 0.025, 0.050 and 0.075 in. U/S)
S19	High pressure impeller
S20	First stage impeller
S21	Second stage impeller
S22	Impeller shaft
S26	Hex nut, 1/2-20
S27	Cotter pin, SS, 1/8 x 1-3/4 in.
S30	End yoke with U-bolts
S32*	Hex hd cap screw, 1/2-20 x 1-3/4 in. or 1/2-13 x 1-1/4 in., grade 5
S35*	Hex hd cap screw, 1/2-13 x 1-1/4 in., grade 5
S36	Lock washer, 1/2 in.
S38	Square key, 5/16 x 1-5/16, 1-9/16, 2-1/8 or 2-5/16 in.
S39	Square key, SS, 5/16 x 1-3/8 in.
S41	Lubrication fitting, 1/8 in.
S45*	Bearing spacer (used after 12/18/92)

REF NO.	DESCRIPTION
S46*	Bearing seal (used after 12/18/92)
S47	Tachometer driven gear
S48	Spirol pin, SS, 1/8 x 3/8 in.
S49*	Tachometer gear bushing
S50	Retaining ring replacement kit
S51	Soft ring packing
S52	Flinger grommet
S53	Flinger disc
S54	Outboard cap
S55	Gasket
S56*	Square hd pipe plug, steel, 1/4 in.
S57	Oil seal, 1-5/8 x 2-3/4 in.
S58	Lube relief fitting, 1/8 in.
S59	Retaining ring
S60	Lock washer, 3/8 in.
S61	Hex hd cap screw, 3/8-16 x 1 in.
S62	Gasket
S63*	Socket hd cap screw, 5/16-18 x 1 in. or 1-1/4 in.
S64	Mechanical seal (refer to S97 or S98)
S65	Retaining ring
S66	Throttle bushing
S67	Lock washer, 5/16 in.
S68	O-ring, 3-1/4 x 3-1/2 in.
S69	Retaining ring

## CM Series Impeller Shaft Assembly for Waterous Two and Three Stage Fire Pumps

REF NO.	DESCRIPTION
S72	Ball bearing
S73	Spring pin, 3/16 x 1/2 in.
S74	Tachometer drive gear
S75	Oil seal, 1-23/32 x 2-3/4 in.
S76	Shaft nut, 1-20
S77	Tachometer gear housing assembly
S78	Tachometer gear spacer
S79	Outboard bearing housing
S81	Tachometer sleeve
S82	Cotter pin, SS, 1/8 x 1 in.
S83	Hex castle nut, SS, 3/4-16
S84	Impeller spacer
S85	Flinger ring
S86	Ball bearing, double row
S87	Retaining ring
S88	Flinger
S89	Bearing spacer
S90	Oil seal housing
S91	Oil seal, 1-7/16 x 2-3/4 in.
S92	Oil seal, 1-1/2 x 2-3/4 in.
S93	Flat washer, 5/16, zinc plated
S94	Packing replacement kit

REF NO.	DESCRIPTION
S96	Housing spacer
S97	Outboard end mechanical seal repair kit
S98	Drive end mechanical seal repair kit
S99	Bearing lock nut
S100	Bearing lock washer
S101	Tachometer mounting plate
S102	Tachometer gear housing
S103	Tachometer drive gear
S104	Spirol pin
S105	Socket hd screw
S107	Hex hd screw
S108	Gasket
S109	Oil pump adapter
S110	Plastic shim
S111	Oil pump
S112	Hex hd screw
S113	Oil pump gasket
S114	Retaining ring
S115	Bearing housing plug
S116	Bearing shield
S500	Complete impeller shaft assembly

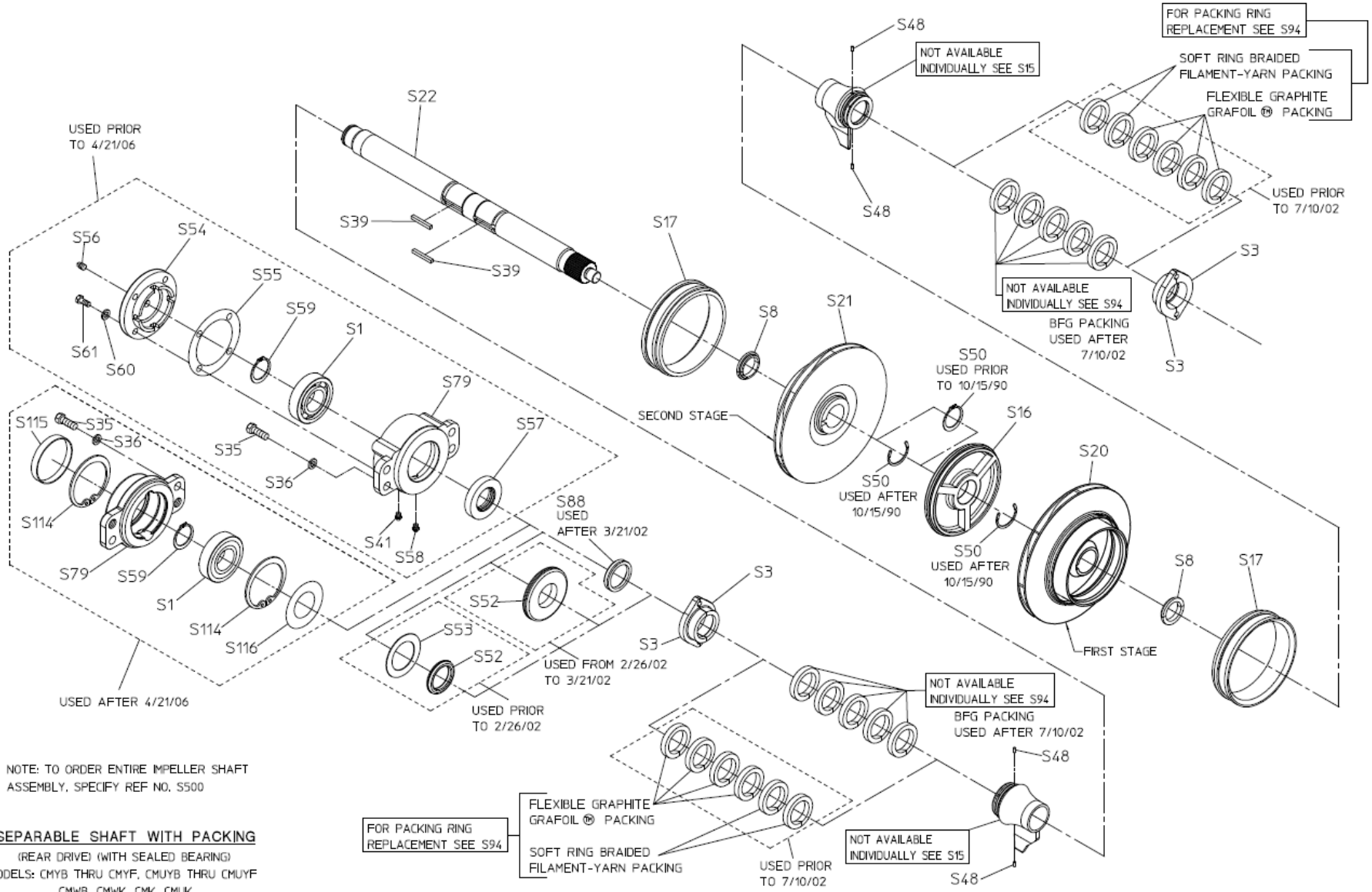

NOTE: TO ORDER ENTIRE IMPELLER SHAFT ASSEMBLY, SPECIFY REF NO. S500

**SEPARABLE SHAFT WITH PACKING**  
 (REAR DRIVE) (WITH SEALED BEARING)  
 MODELS: CMYB THRU CMYF, CMUYB THRU CMUYF  
 CMWB, CMWK, CMK, CMUK

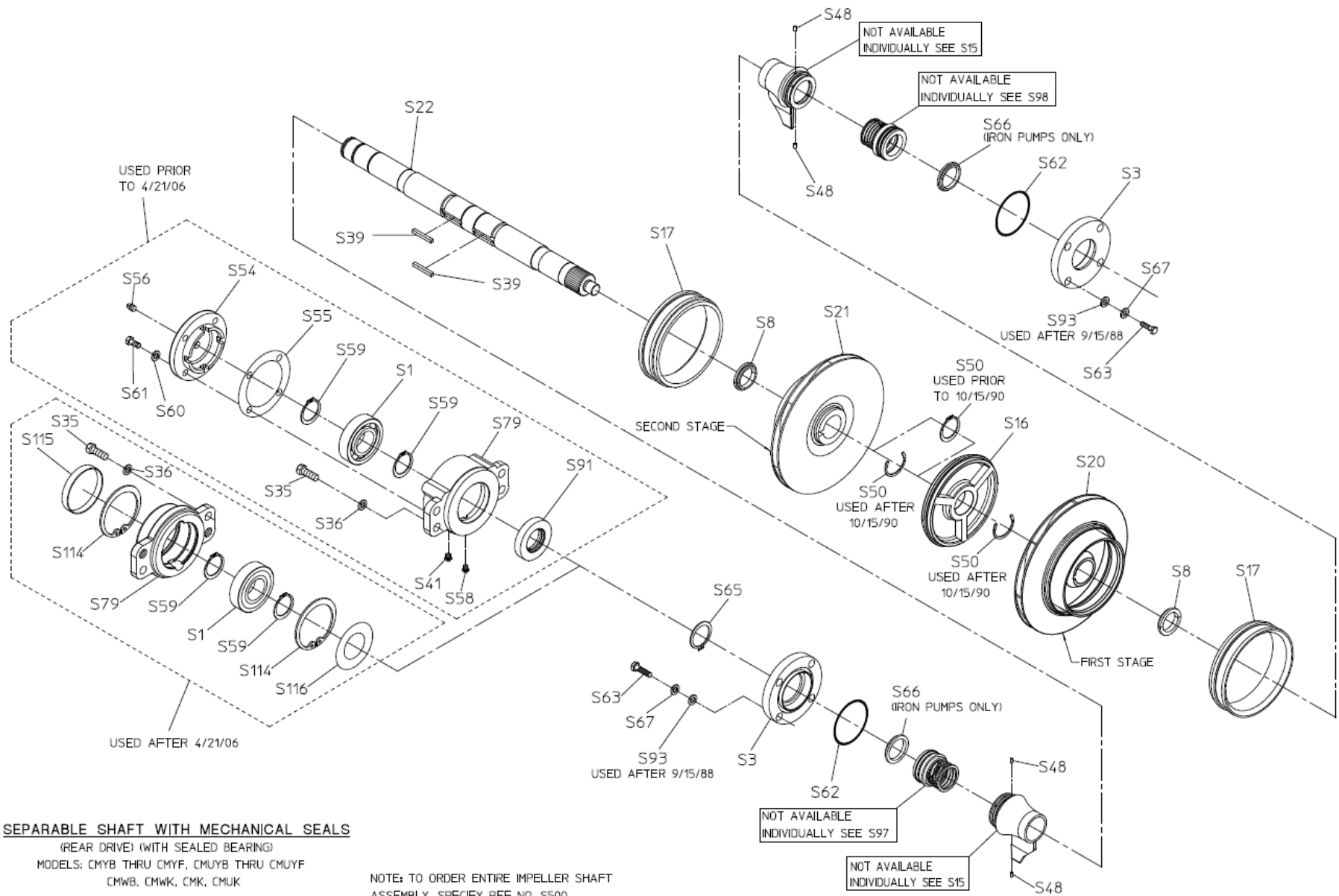

**SEPARABLE SHAFT WITH MECHANICAL SEALS**

(REAR DRIVE) (WITH SEALED BEARING)  
 MODELS: CMYB THRU CMYF, CMUYB THRU CMUYF  
 CMWB, CMWK, CMK, CMUK

NOTE: TO ORDER ENTIRE IMPELLER SHAFT  
 ASSEMBLY, SPECIFY REF NO. S500

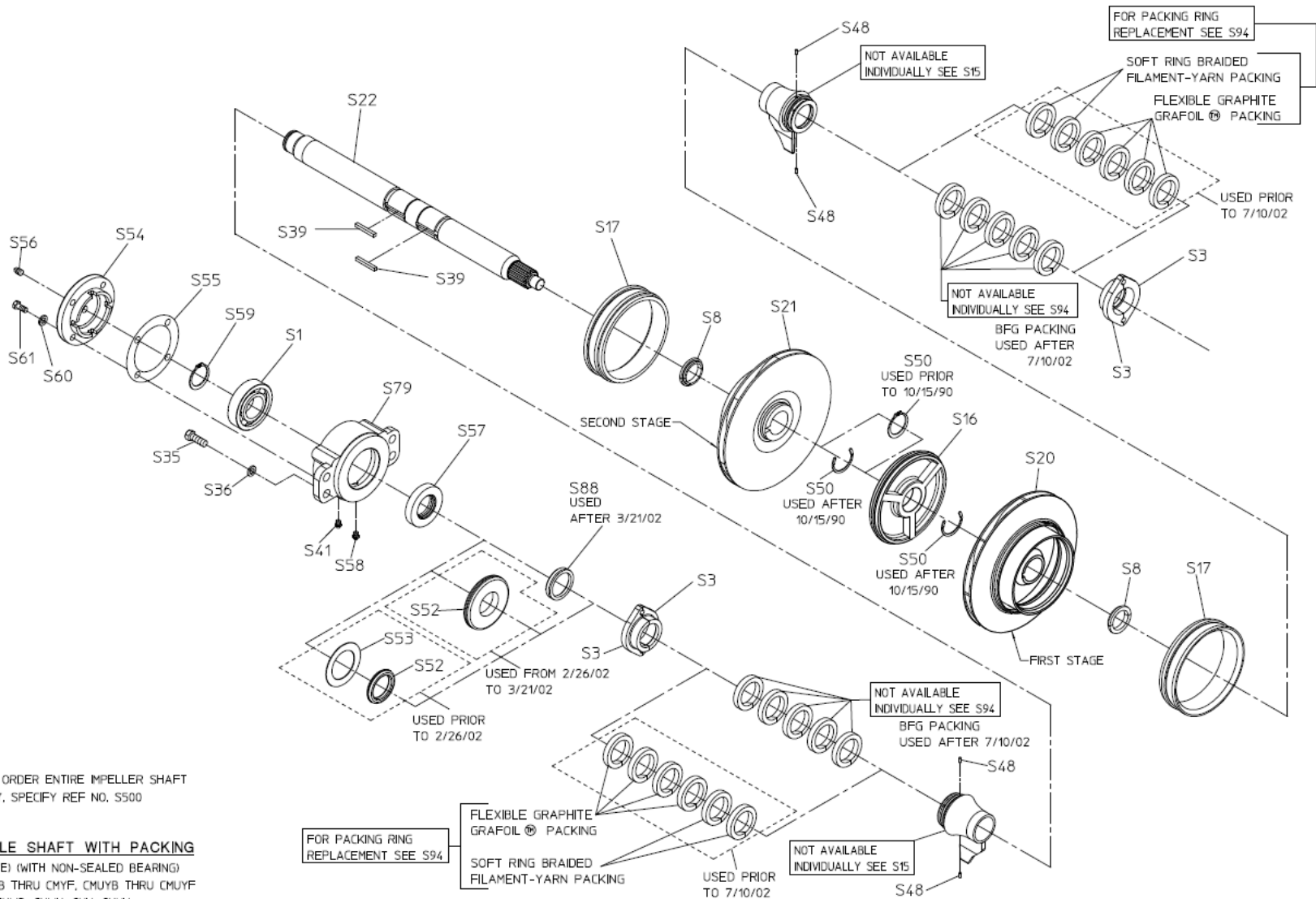

NOTE: TO ORDER ENTIRE IMPELLER SHAFT ASSEMBLY, SPECIFY REF NO. S500

**SEPARABLE SHAFT WITH PACKING**  
 (REAR DRIVE) (WITH NON-SEALED BEARING)  
 MODELS: CMYB THRU CMYF, CMUYB THRU CMUYF  
 CMWB, CMWK, CMK, CMLK

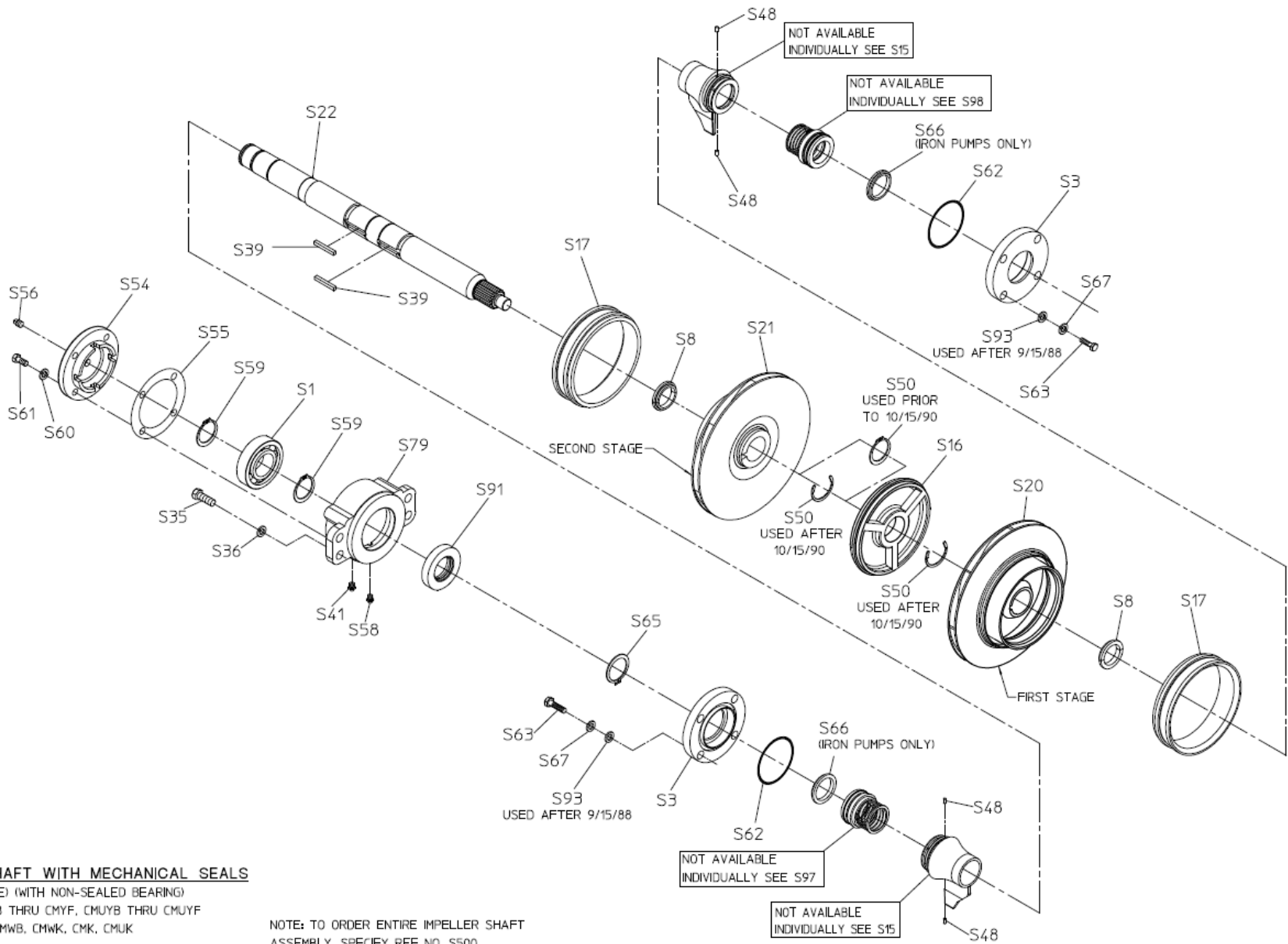

**SEPARABLE SHAFT WITH MECHANICAL SEALS**

(REAR DRIVE) (WITH NON-SEALED BEARING)  
 MODELS: CMYB THRU CMYF, CMUYB THRU CMUYF  
 CMWB, CMWK, CMK, CMUK

NOTE: TO ORDER ENTIRE IMPELLER SHAFT  
 ASSEMBLY, SPECIFY REF NO. S500

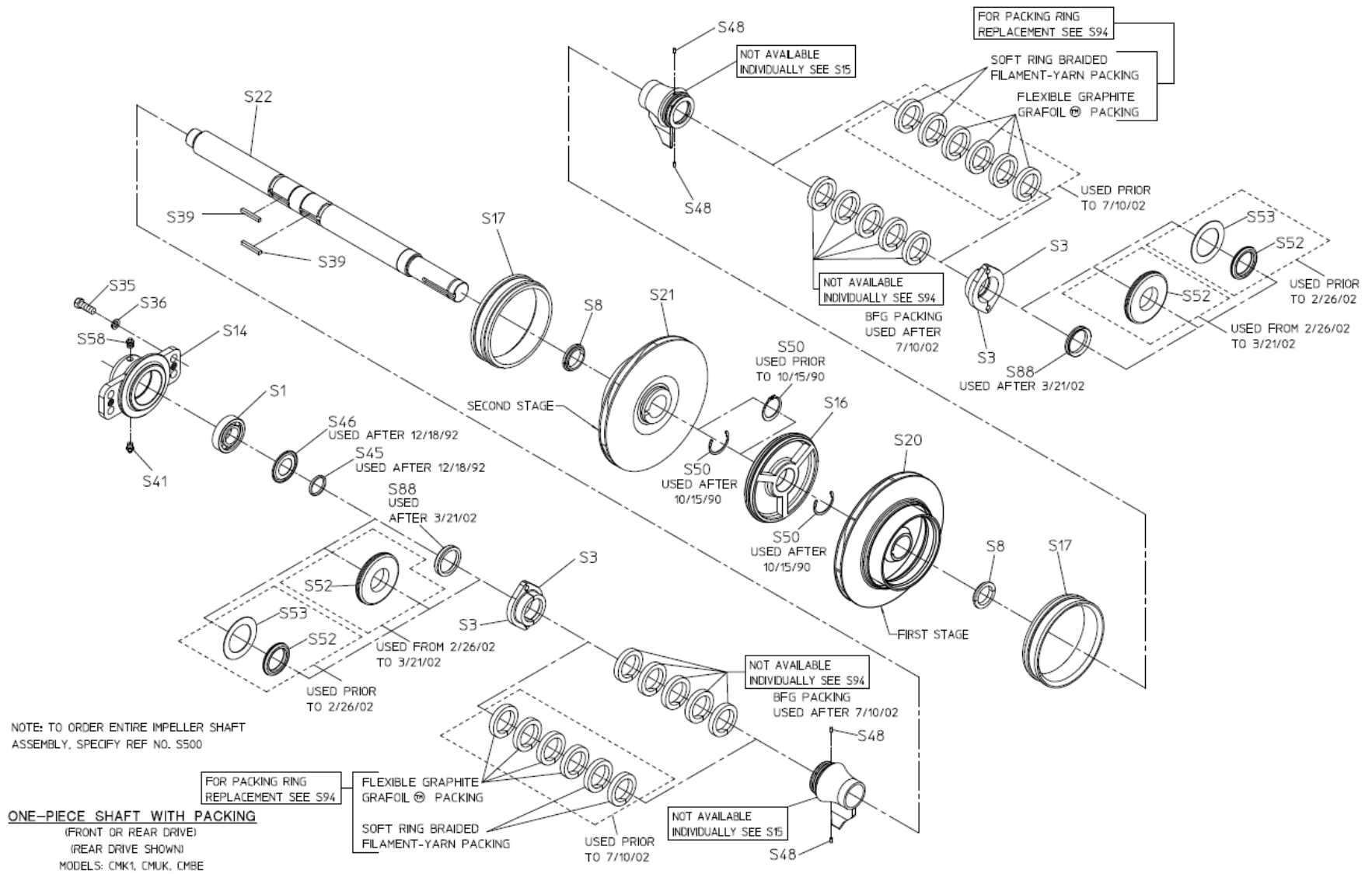



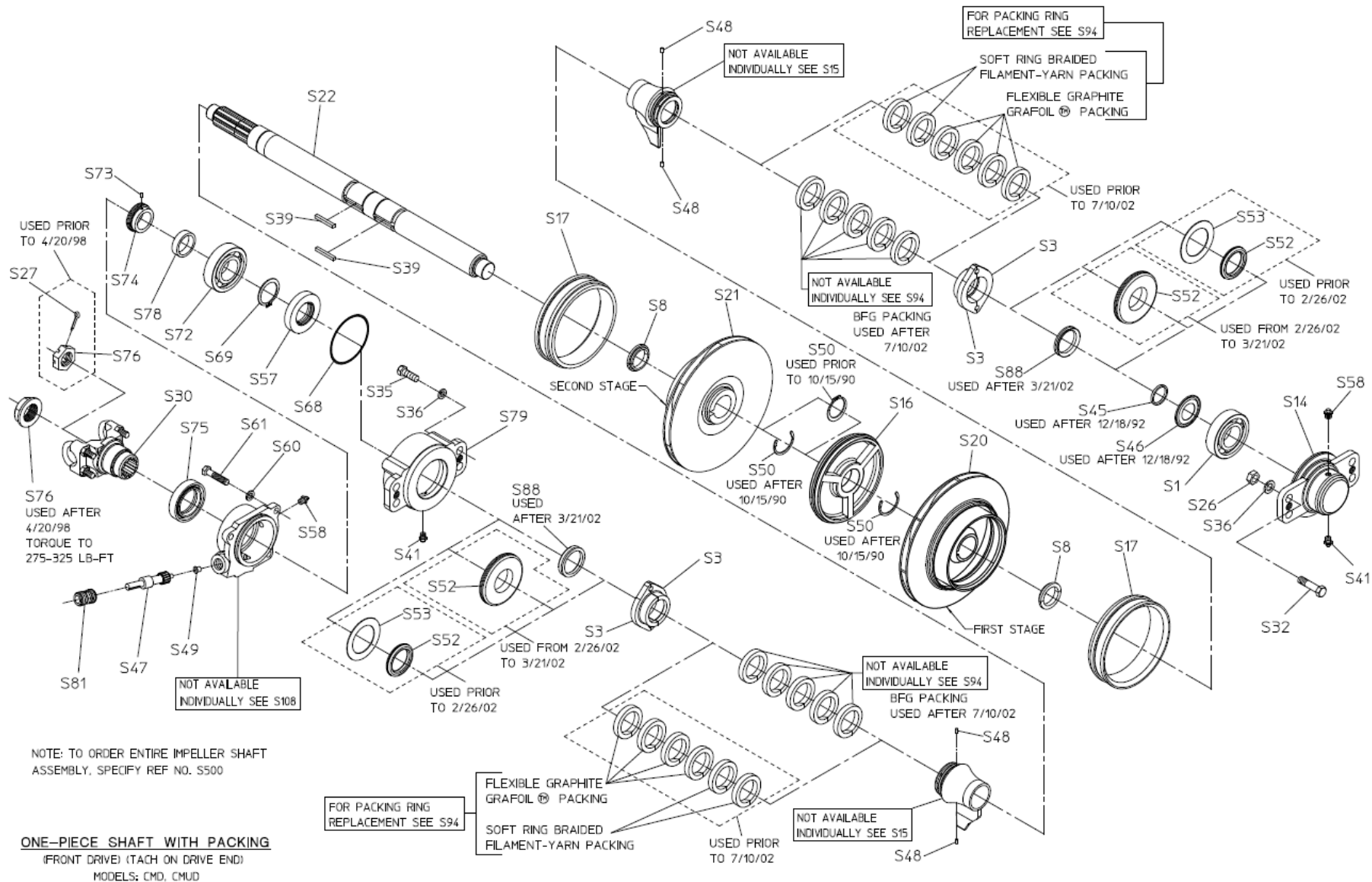

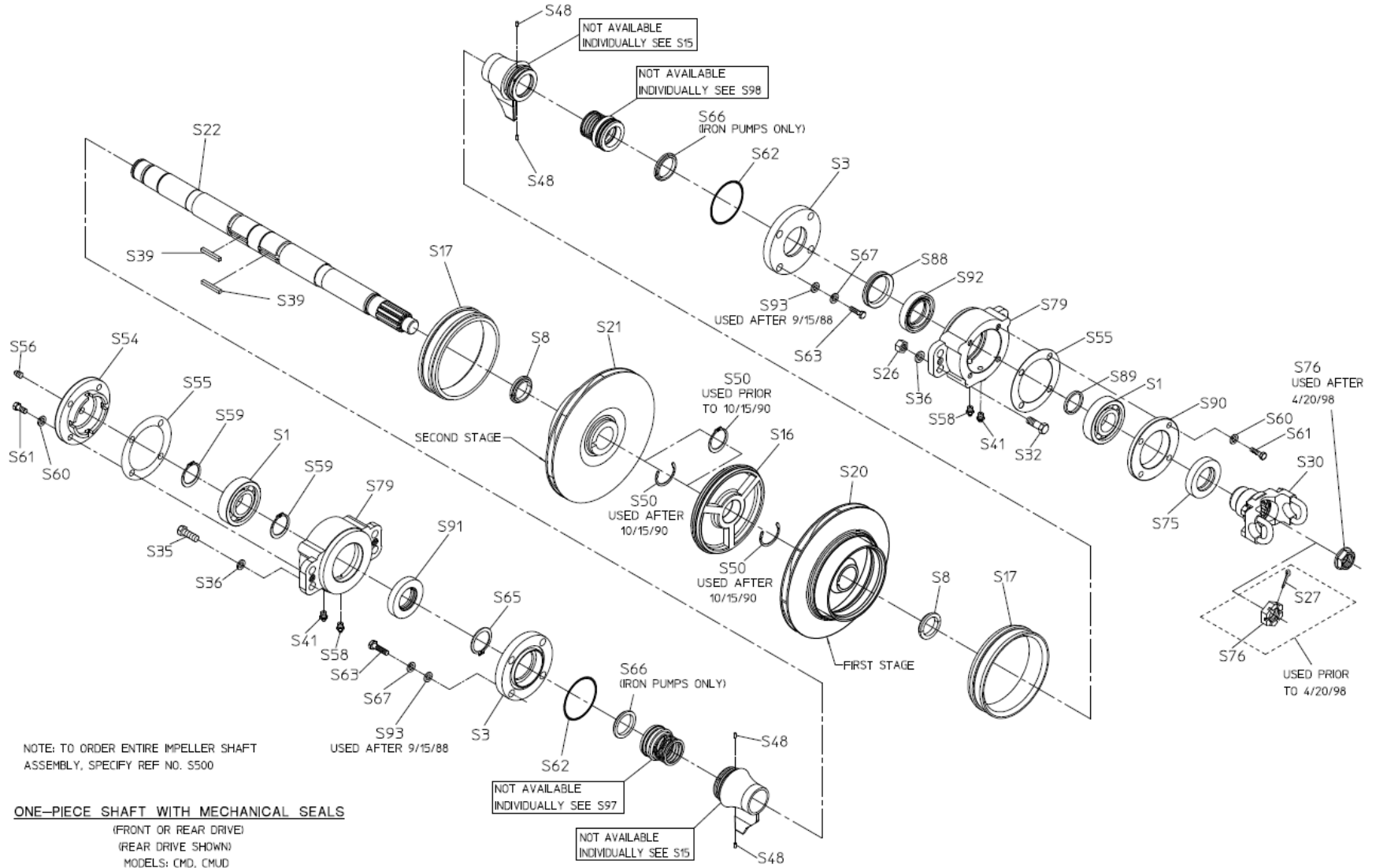

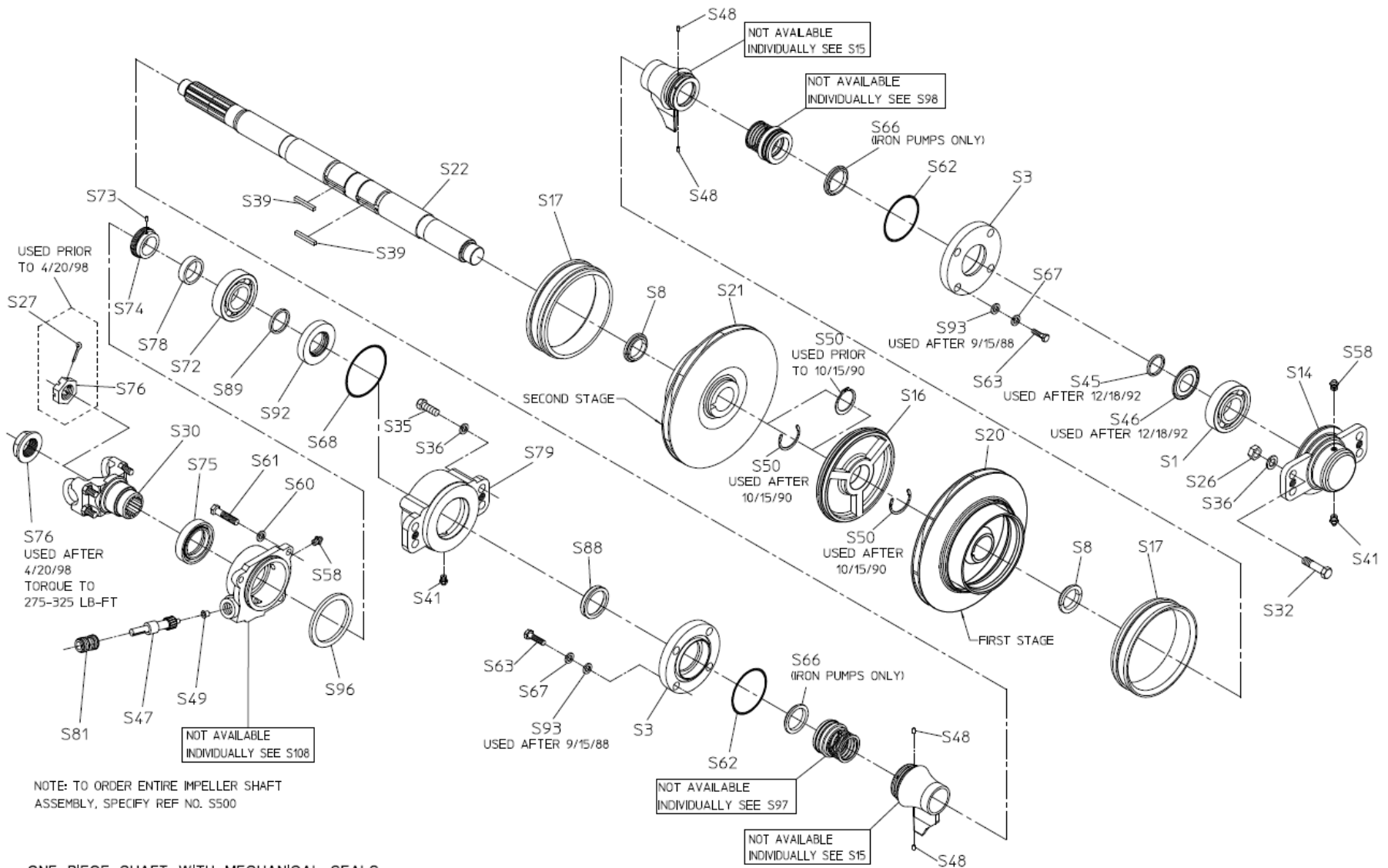

NOTE: TO ORDER ENTIRE IMPELLER SHAFT ASSEMBLY, SPECIFY REF NO. S500

**ONE-PIECE SHAFT WITH MECHANICAL SEALS**  
 (FRONT DRIVE) (TACH ON DRIVE END)  
 MODELS: CMD, CMUD

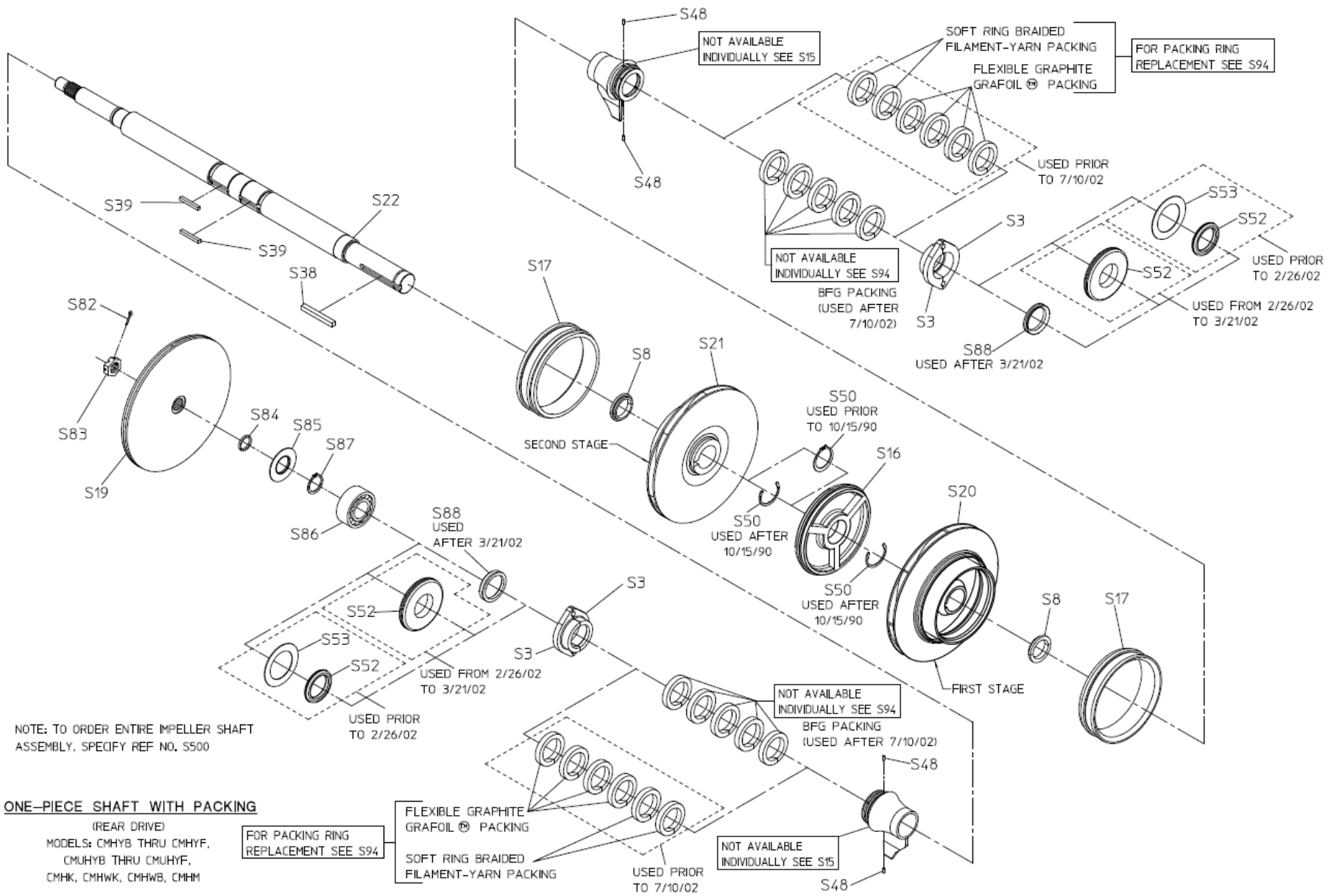

NOTE: TO ORDER ENTIRE IMPELLER SHAFT ASSEMBLY, SPECIFY REF NO. S500

**ONE-PIECE SHAFT WITH PACKING**  
 (REAR DRIVE)  
 MODELS: CMHYB THRU CMHYF,  
 CMUHYB THRU CMUHYF,  
 CMHK, CMHWK, CMHWB, CMHM

FOR PACKING RING REPLACEMENT SEE S94

FLEXIBLE GRAPHITE GRAFOIL® PACKING  
 SOFT RING BRAIDED FILAMENT-YARN PACKING

NOT AVAILABLE INDIVIDUALLY SEE S15

NOT AVAILABLE INDIVIDUALLY SEE S94  
 BFG PACKING (USED AFTER 7/10/02)

FOR PACKING RING REPLACEMENT SEE S94

NOT AVAILABLE INDIVIDUALLY SEE S94  
 BFG PACKING (USED AFTER 7/10/02)

USED PRIOR TO 7/10/02  
 USED PRIOR TO 2/26/02  
 USED FROM 2/26/02 TO 3/21/02

S50 USED PRIOR TO 10/15/90

S50 USED AFTER 10/15/90

S50 USED AFTER 10/15/90

S88 USED AFTER 3/21/02

USED FROM 2/26/02 TO 3/21/02

USED PRIOR TO 7/10/02

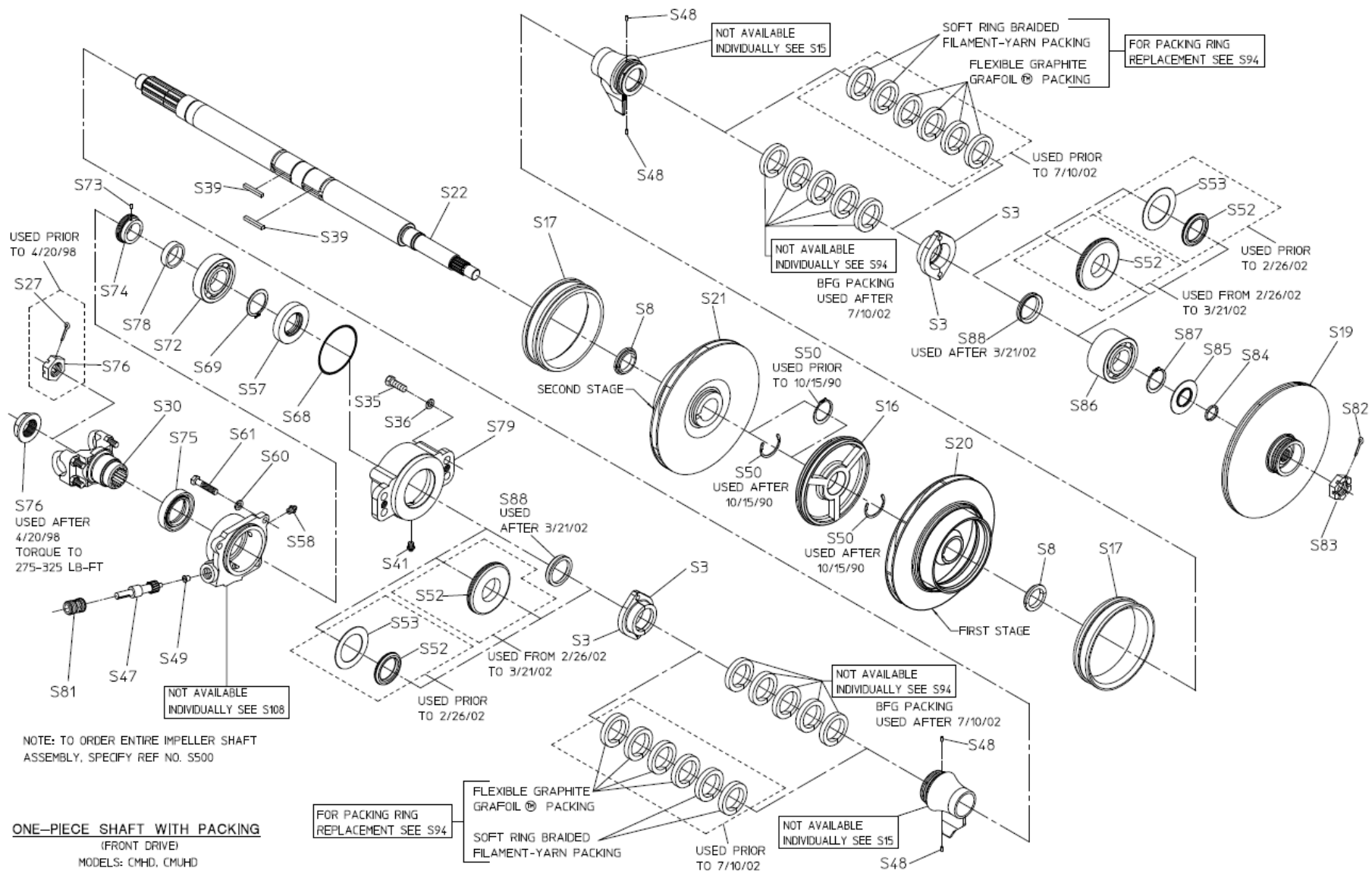

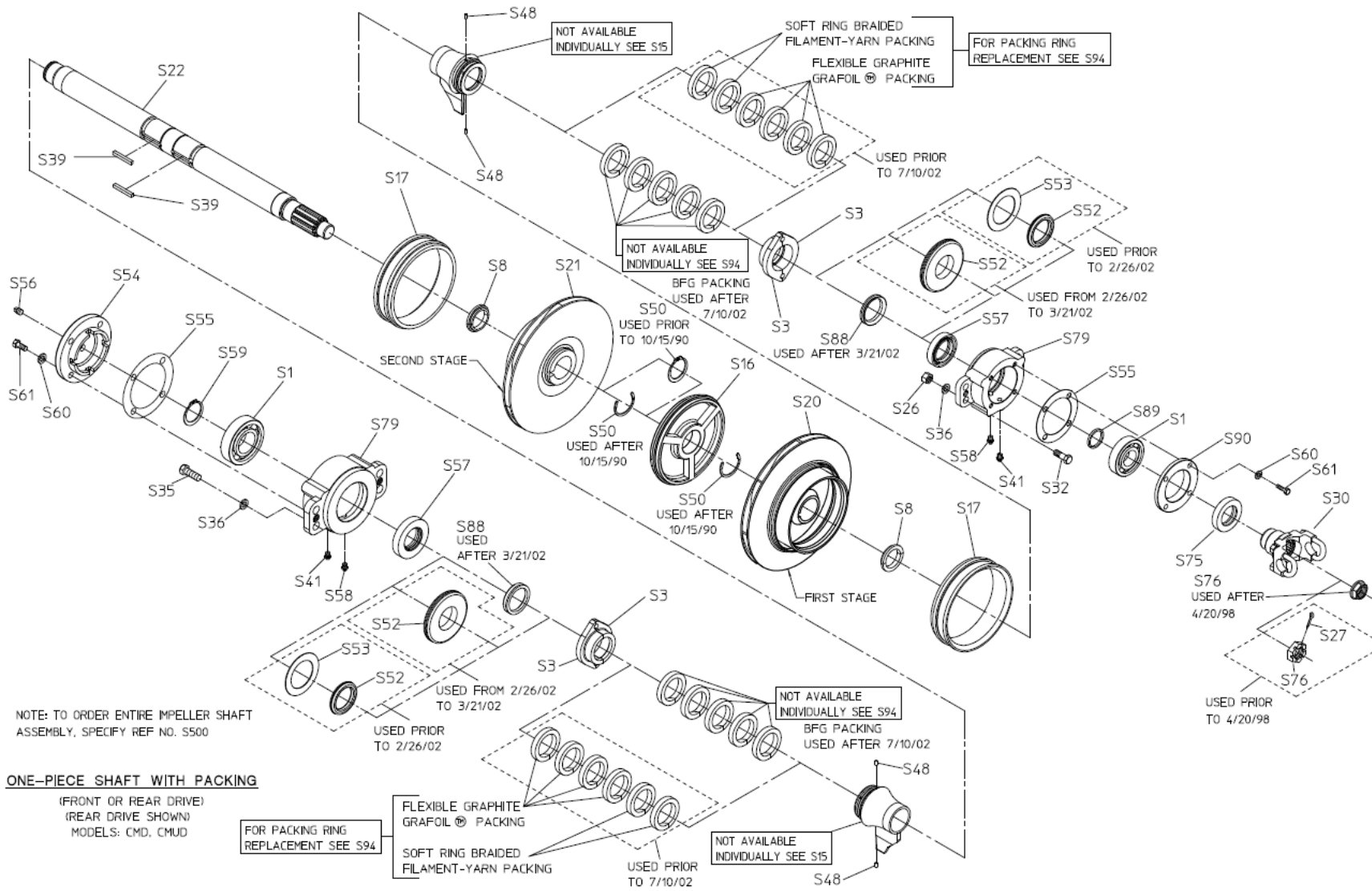

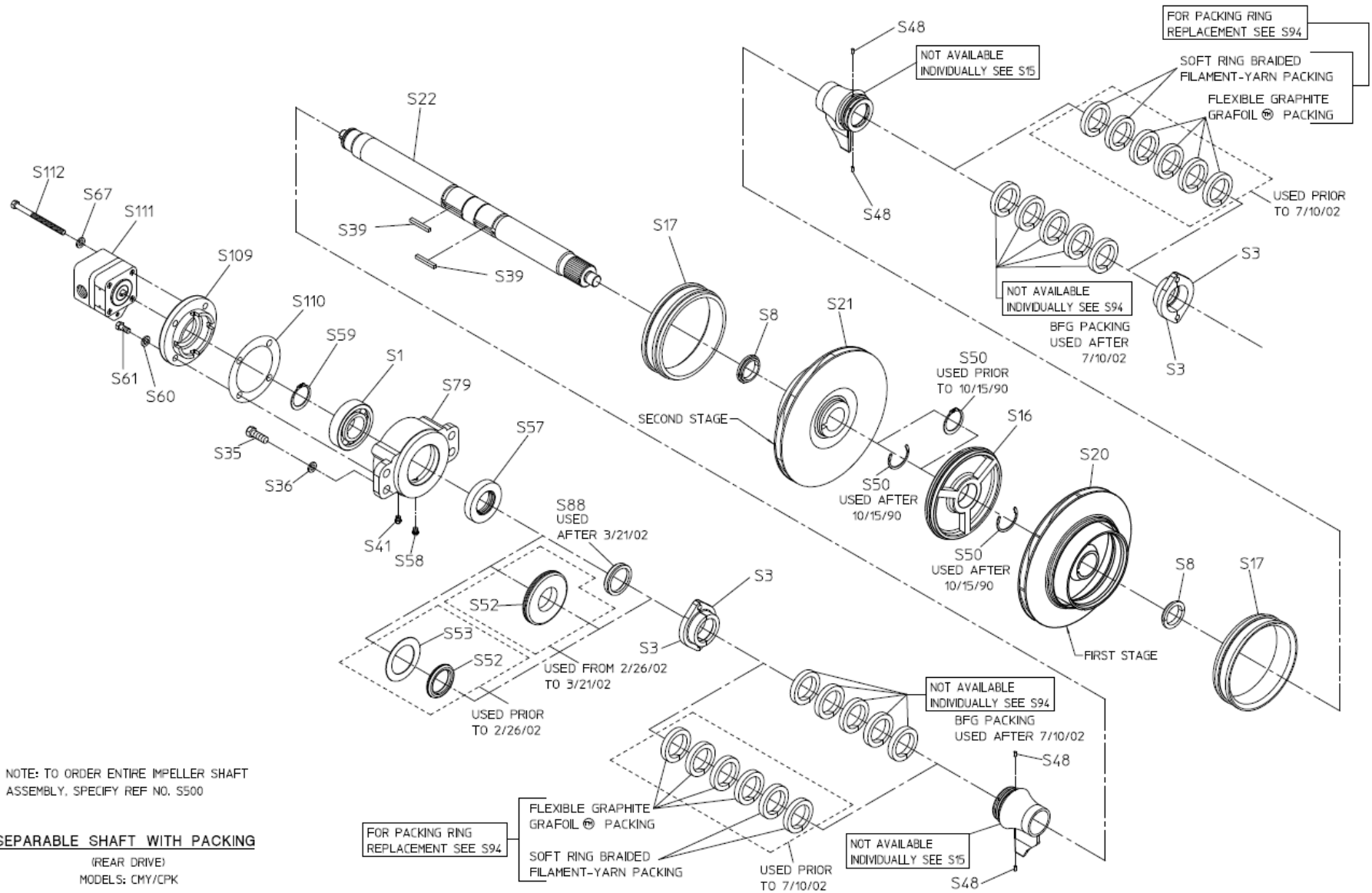

NOTE: TO ORDER ENTIRE IMPELLER SHAFT ASSEMBLY, SPECIFY REF NO. S500

**SEPARABLE SHAFT WITH PACKING**  
(REAR DRIVE)  
MODELS: CMY/CPK

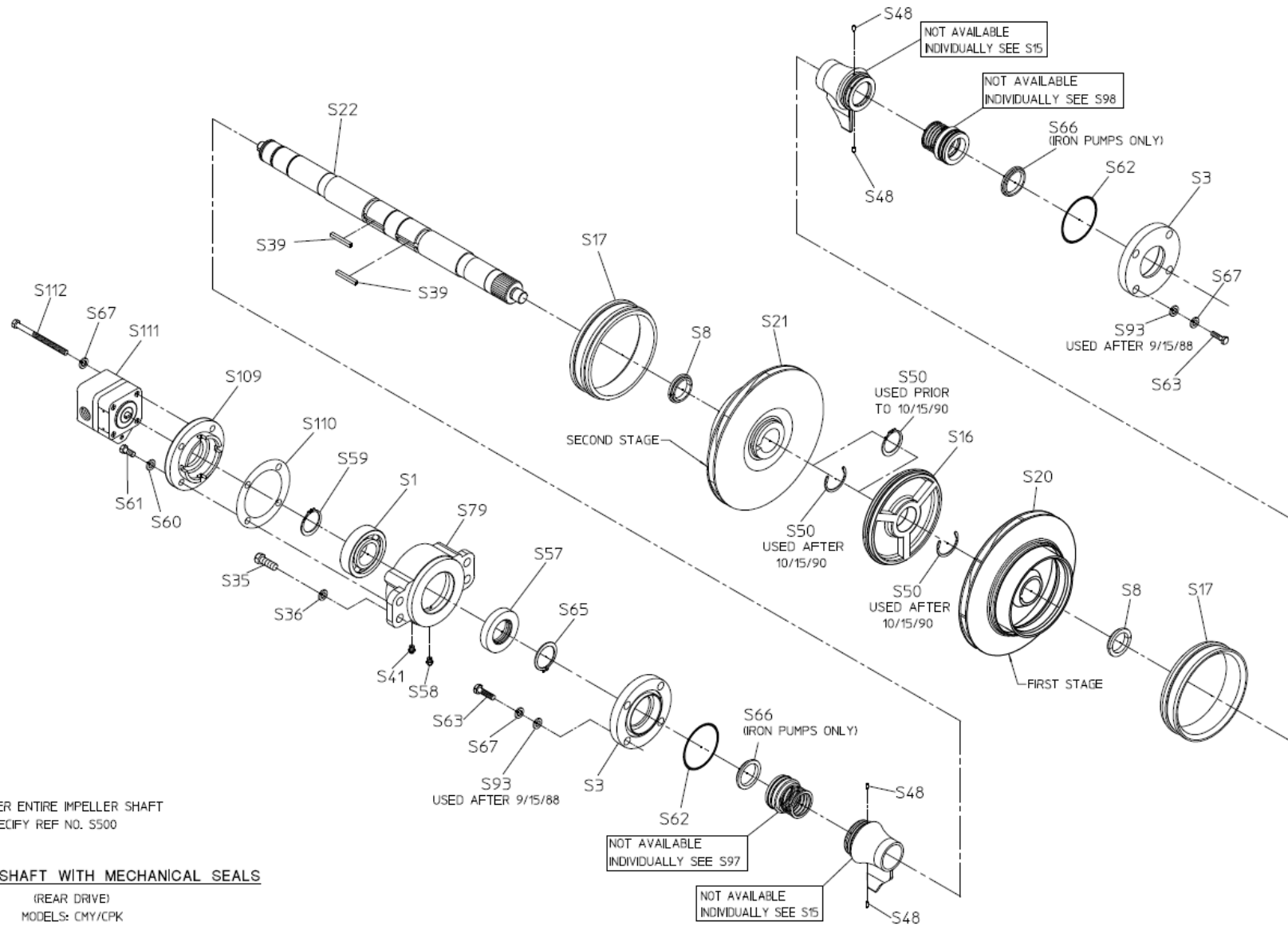

NOTE: TO ORDER ENTIRE IMPELLER SHAFT ASSEMBLY, SPECIFY REF NO. S500

**SEPARABLE SHAFT WITH MECHANICAL SEALS**

(REAR DRIVE)  
MODELS: CMY/CPK



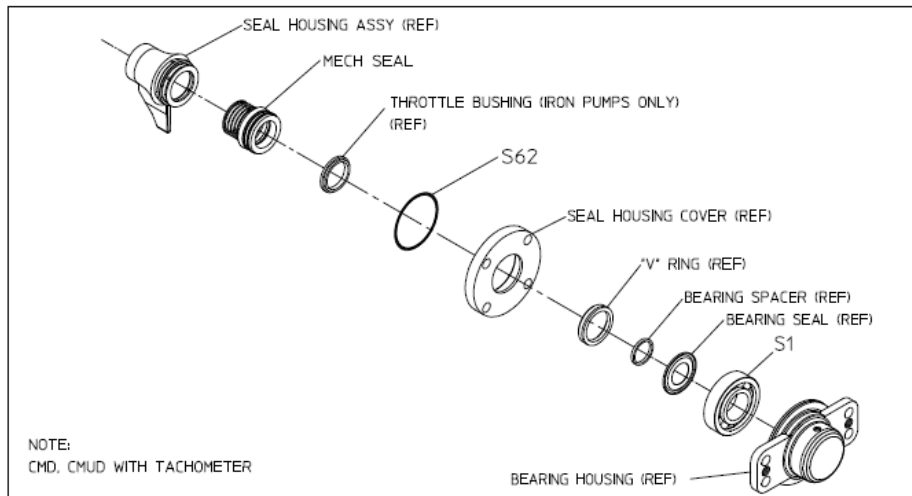

REF NO. S97 SEAL REPLACEMENT KIT CMD PUMPS W/ TACHOMETER (OUTBOARD END)

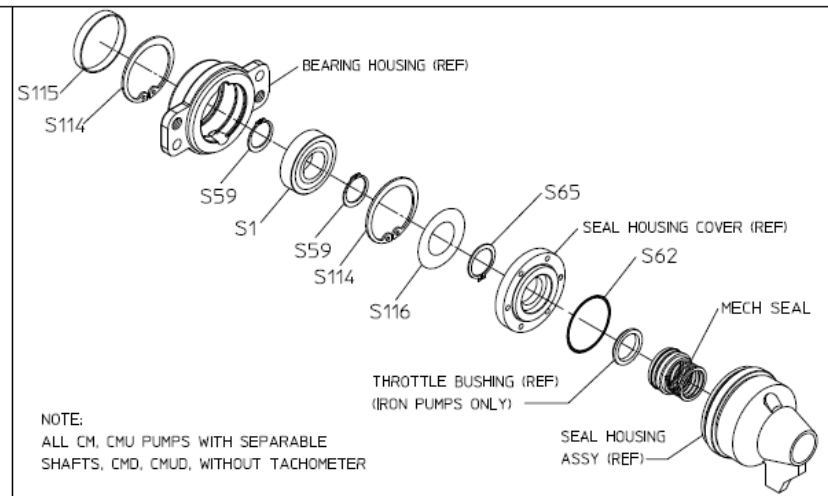

REF NO. S97 SEAL REPLACEMENT KIT (OUTBOARD END W/SEALED BEARING)

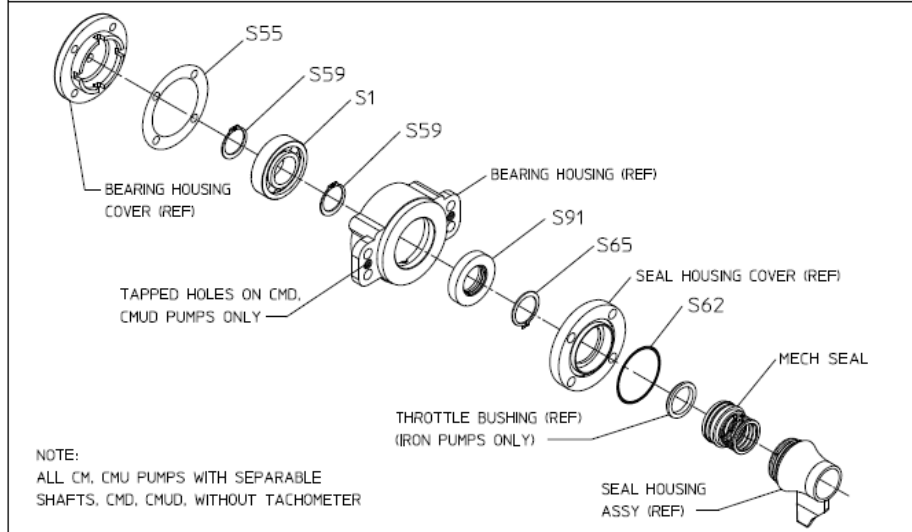

REF NO. S97 SEAL REPLACEMENT KIT (OUTBOARD END)

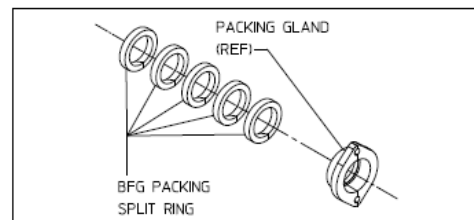
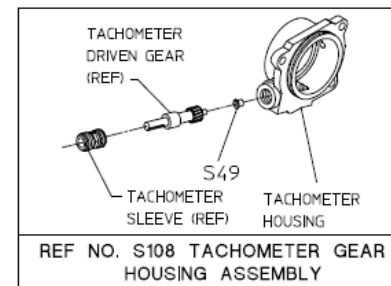
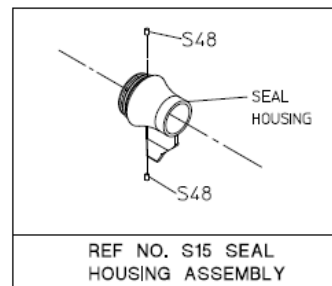

NOTE:  
ALL PARTS LABELED WITH (REF) ARE NOT INCLUDED IN REPLACEMENT KIT, AND ARE SHOWN FOR REFERENCE ONLY.

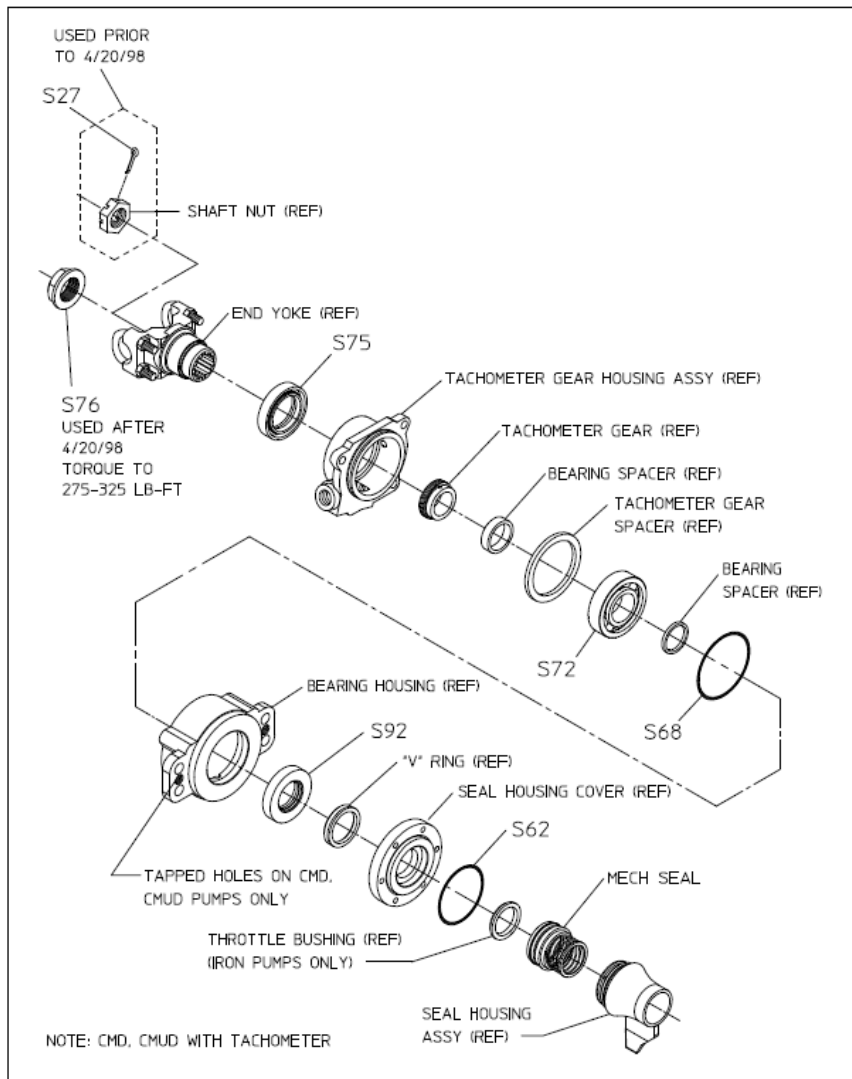

REF NO. S98 SEAL REPLACEMENT KIT FOR CMD PUMPS W/ TACHOMETER (DRIVE END)

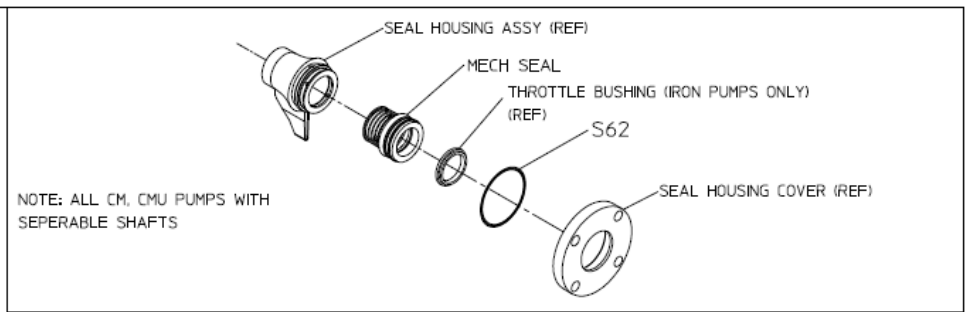

REF NO. S98 SEAL REPLACEMENT KIT FOR CM PUMPS (DRIVE END)

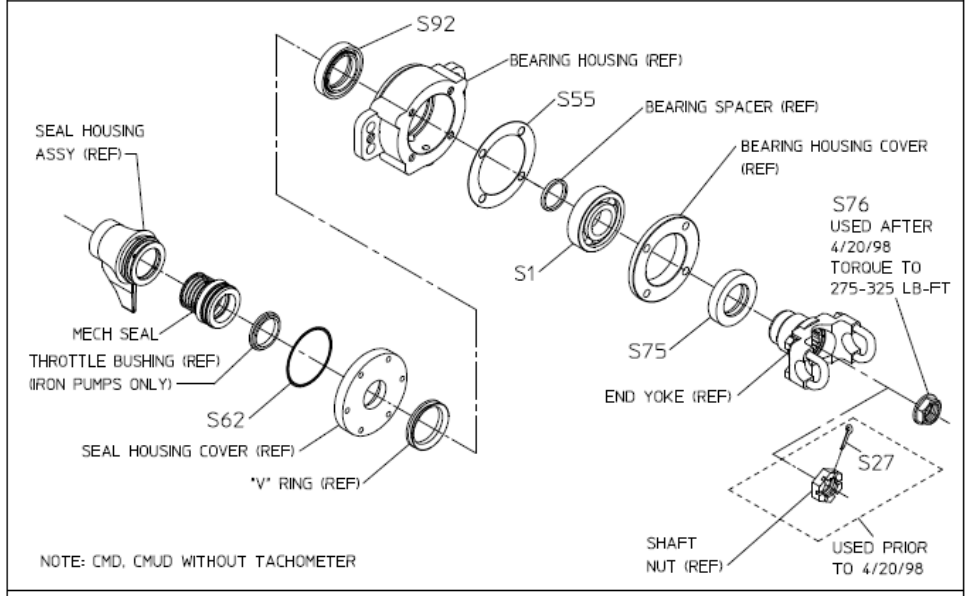

REF NO. S98 SEAL REPLACEMENT KIT FOR CMD PUMPS W/O TACHOMETER (DRIVE END)

NOTE:  
ALL PARTS LABELED WITH (REF) ARE NOT INCLUDED IN REPLACEMENT KIT, AND ARE SHOWN FOR REFERENCE ONLY.