



Document Number SPL81614	Issue Date 11/88	Rev. Date 7/30/24
------------------------------------	----------------------------	-----------------------------

Medium Duty K Transmission Service Parts List

Pump			See Page					
Model (Located on Serial Plate)		Type	Transmission Input Shaft				Transmission Case	
Main Pump	Combination Pump		1-1/8 in. Keyed	Hydraulic Pump Adapter	Splined	Optional Ta-chometer	Mounting to Pump	Mounting Positions
CLVK, CLRK, CLSK		-	Non-Extended Impeller Shaft	2, 3	4, 5			
			Extended Impeller Shaft for Driving a Compressor	6, 7	8, 9			
CPK-1, CPK-2		-	Non-Extended Impeller Shaft	2, 3	4, 5	-	14, 15	
			Extended Impeller Shaft for Driving a Compressor	6, 7	8, 9			
CPK-3	Pumps Built Prior to December 1, 1990	-	Non-Extended Impeller Shaft	2, 3	4, 5			
	Pumps Built After December 1, 1990	-	Non-Extended Impeller Shaft	10, 11	4, 5			
CPK-4		-	Non-Extended Impeller Shaft	2, 3	-			
CMYB, CMYC, CMYD, CMYE, CMYF CMYBX, CMYCX, CMYDX, CMYEX, CMYFX CMUYB, CMUYC, CMUYD, CMUYE, CMUYF CMUYBX, CMUYCX, CMUYDX, CMUYEX, CMUYFX		CPK-1, CPK-2	Combination Pump CPK-1 or CPK-2 is mounted on the Rear of the Main Pump Transmission and acts as an Extra Pressure Stage	-	-			
CMC10B, CMC10C, CMC10D, CMC10E, CMC10F CMUC10B, CMUC10C, CMUC10D, CMUC10E, CMUC10F								
CMC20B, CMC20C, CMC20D, CMC20E, CMC20F CMUC20B, CMUC20C, CMUC20D, CMUC20E, CMUC20F								
CMPA, CMUPA								
CSYB, CSYC, CSYD, CSYE, CSYF CSYBX, CSYCX, CSYDX, CSYEX, CSYFX CSUYB, CSUYC, CSUYD, CSUYE, CSUYF CSUYBX, CSUYCX, CSUYDX, CSUYEX, CSUYFX								
CSC10B, CSC10C, CSC10D, CSC10E, CSC10F CSUC10B, CSUC10C, CSUC10D, CSUC10E, CSUC10F								
CSC20B, CSC20C, CSC20D, CSC20E, CSC20F CSUC20B, CSUC20C, CSUC20D, CSUC20E, CSUC20F								
CSPA, CSUPA								
CGGWB, CGGWBX								

Waterous Company 125 Hardman Avenue South, South St. Paul, Minnesota 55075 USA (651) 450-5000

Note: When ordering parts, provide Pump, Transmission or PTO Serial Number.

**Non-Extended Impeller Shaft
1-1/8 in. Keyed Input Shaft
Models: CLVK, CLRK, CLSK, CPK-1, CPK-2, CPK-3, CPK-4**

REF. NO.	DESCRIPTION
T1	Woodruff Key
T2	Serial Plate (CPK-1, CPK-2, CPK-3, CPK-4 Models Only)
T3	Driven Gear
T4	Gasket
T6	Gasket
T8	Gasket
T9	Bearing Cover
T10	Oil Seal Housing
T11	Drive Shaft
T13	Gear Case Subassembly
T14	Dowel Pin, 3/8 x 1 in.
T15	Drive Gear
T17	Breather, 1/2 NPT
T18	Magnetic Drain Plug, 1/2 NPT
T19	Hex Hd Screw, 3/8-16 x 1-1/4 in.
T24	Oil Seal

REF. NO.	DESCRIPTION
T25	Lockwasher, 3/8 in.
T28	Retaining Ring
T31	Pipe Plug, 1/2 NPT
T32	Drive Screw, No. 6 x 1/4 in.
T33	Ball Bearing
T34	Ball Bearing
T50	Oil Seal
T67	Oil Level Plate
T69	Street Elbow, 45 Degree x 1/2 NPT
T75	Bearing Spacer
T76	Square Key
T77	Castle Nut or Nylok Nut
T79	Flat Washer, 3/4 in.
T80	Cotter Pin, 1/8 x 1-1/2 in.
T92	Hex Head Screw, 3/8-16 x 1 in.

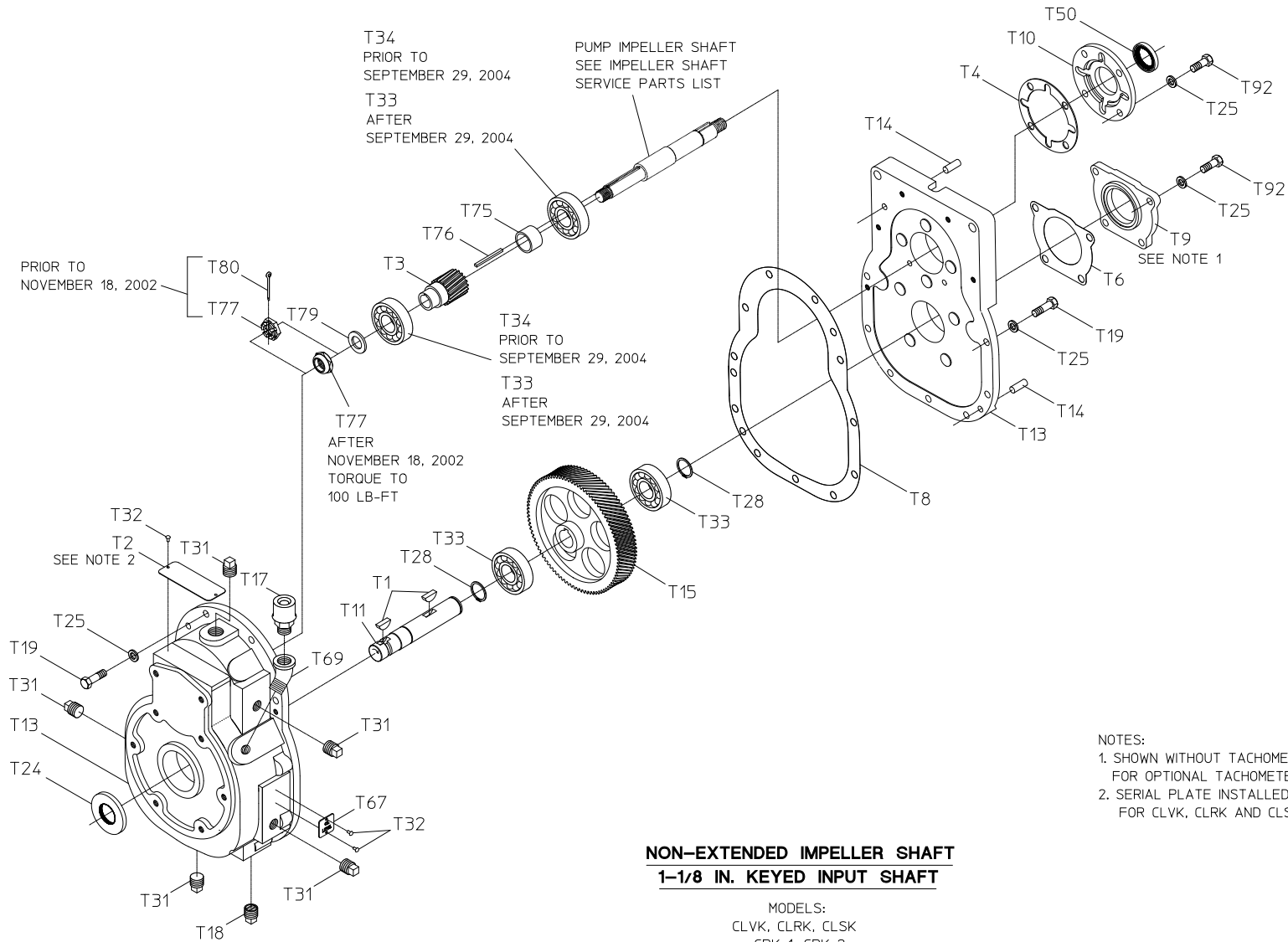

- NOTES:
1. SHOWN WITHOUT TACHOMETER DRIVE. SEE PAGE 15 FOR OPTIONAL TACHOMETER.
 2. SERIAL PLATE INSTALLED ON PUMP VOLUTE BODY FOR CLVK, CLRK AND CLSK MODELS.

NON-EXTENDED IMPELLER SHAFT
1-1/8 IN. KEYED INPUT SHAFT

MODELS:
CLVK, CLRK, CLSK
CPK-1, CPK-2
CPK-3, CPK-4 (PRIOR TO DECEMBER 1, 1990)

**Non-Extended Impeller Shaft
Hydraulic Pump Adapter Input Shaft
Models: CLVK, CLRK, CLSK, CPK-1, CPK-2, CPK-3**

REF. NO.	DESCRIPTION
T1	Woodruff Key
T2	Serial Plate (CPK-1, CPK-2 Models Only)
T3	Driven Gear
T4	Gasket
T6	Gasket
T8	Gasket
T9	Bearing Cover
T10	Oil Seal Housing
T11	Drive Shaft
T13	Gear Case Subassembly
T14	Dowel Pin, 3/8 x 1 in.
T15	Drive Gear
T17	Breather, 1/2 NPT
T18	Magnetic Drain Plug, 1/2 NPT
T19	Hex Hd Screw, 3/8-16 x 1-1/4 in.
T24	Oil Seal
T25	Lockwasher, 3/8 in.
T26	Lockwasher, 7/16 in.

REF. NO.	DESCRIPTION
T28	Retaining Ring
T31	Pipe Plug, 1/2 NPT
T32	Drive Screw, No. 6 x 1/4 in.
T33	Ball Bearing
T34	Ball Bearing
T50	Oil Seal
T67	Oil Level Plate
T69	Street Elbow, 45 Degree x 1/2 NPT
T75	Bearing Spacer
T76	Square Key
T77	Castle Nut or Nylok Nut
T79	Flat Washer, 3/4 in.
T80	Cotter Pin, 1/8 x 1-1/2 in.
T87	Adapter Bushing
T88	Hydraulic Motor/Pump Adapter
T90	Hex Head Screw, 7/16-14 x 1 in.
T91	Socket Head Scew, 7/16-14 x 1-1/4 in.
T92	Hex Head Screw, 3/8-16 x 1 in.

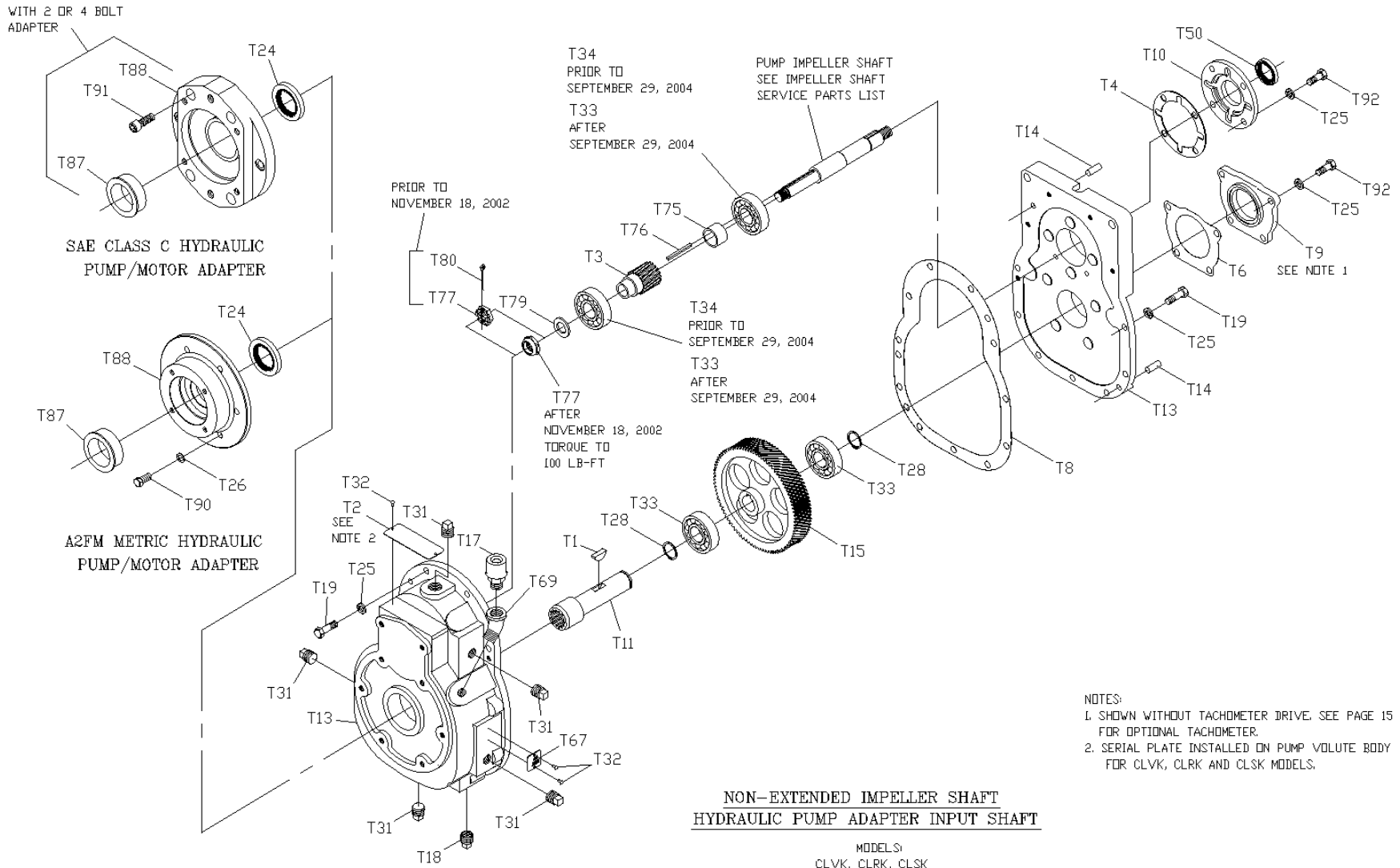

NOTES:
 1. SHOWN WITHOUT TACHOMETER DRIVE. SEE PAGE 15 FOR OPTIONAL TACHOMETER.
 2. SERIAL PLATE INSTALLED ON PUMP VOLUTE BODY FOR CLVK, CLRK AND CLSK MODELS.

**Extended Impeller Shaft
1-1/8 in. Keyed Input Shaft
Models: CLVK, CLRK, CLSK, CPK-1, CPK-2**

REF. NO.	DESCRIPTION
T1	Woodruff Key
T2	Serial Plate (CPK-1, CPK-2 Models Only)
T3	Driven Gear
T4	Gasket
T5	Bearing Spacer
T6	Gasket
T7	Retaining Ring
T8	Gasket
T9	Bearing Cover
T10	Oil Seal Housing
T11	Drive Shaft
T13	Gear Case Subassembly
T14	Dowel Pin, 3/8 x 1 in.
T15	Drive Gear
T18	Magnetic Drain Plug, 1/2 NPT
T19	Hex Hd Screw, 3/8-16 x 1-1/4 in.
T24	Oil Seal
T25	Lockwasher, 3/8 in.
T28	Retaining Ring
T31	Pipe Plug, 1/2 NPT

REF. NO.	DESCRIPTION
T32	Drive Screw, No. 6 x 1/4 in.
T33	Ball Bearing
T34	Ball Bearing
T50	Oil Seal
T67	Oil Level Plate
T75	Bearing Spacer
T76	Square Key
T77	Castle Nut or Nylok Nut
T79	Flat Washer, 3/4 in.
T80	Cotter Pin, 1/8 x 1-1/2 in.
T92	Hex Head Screw, 3/8-16 x 1 in.
T94	Square Key, 5/16 x 2-15/16 in.
T105	Oil Seal Sleeve
T106	Oil Seal
T107	Square Key, 3/16 x 1 in.
T108	Nylok Nut
T109	Bearing Locknut
T110	Bearing Lockwasher

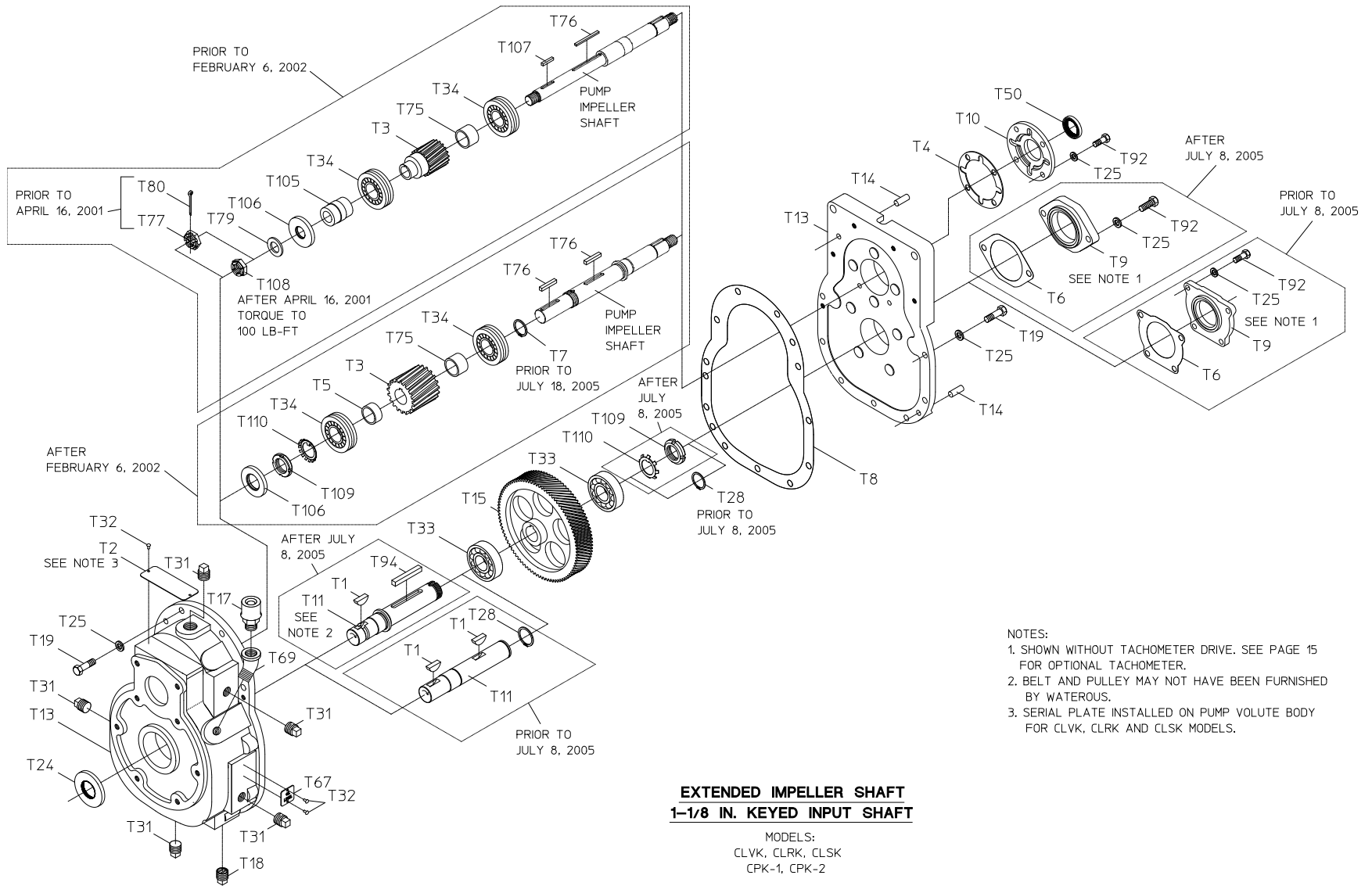

**Extended Impeller Shaft
Hydraulic Pump Adapter Input Shaft
Models: CLVK, CLRK, CLSK, CPK-1, CPK-2**

REF. NO.	DESCRIPTION
T1	Woodruff Key
T2	Serial Plate (CPK-1, CPK-2 Models Only)
T3	Driven Gear
T4	Gasket
T5	Bearing Spacer
T6	Gasket
T7	Retaining Ring
T8	Gasket
T9	Bearing Cover
T10	Oil Seal Housing
T11	Drive Shaft
T13	Gear Case Subassembly
T14	Dowel Pin, 3/8 x 1 in.
T15	Drive Gear
T17	Breather, 1/2 NPT
T18	Magnetic Drain Plug, 1/2 NPT
T19	Hex Hd Screw, 3/8-16 x 1-1/4 in.
T24	Oil Seal
T25	Lockwasher, 3/8 in.
T28	Retaining Ring
T31	Pipe Plug, 1/2 NPT

REF. NO.	DESCRIPTION
T32	Drive Screw, No. 6 x 1/4 in.
T33	Ball Bearing
T34	Ball Bearing
T50	Oil Seal
T67	Oil Level Plate
T69	Street Elbow, 45 Degree x 1/2 NPT
T75	Bearing Spacer
T76	Square Key
T77	Castle Nut or Nylok Nut
T79	Flat Washer, 3/4 in.
T80	Cotter Pin, 1/8 x 1-1/2 in.
T88	Hydraulic Motor/Pump Adapter
T92	Hex Head Screw, 3/8-16 x 1 in.
T94	Square Key, 5/16 x 2-15/16 in.
T105	Oil Seal Sleeve
T106	Oil Seal
T107	Square Key, 3/16 x 1 in.
T108	Nylok Nut
T109	Bearing Locknut
T110	Bearing Lockwasher

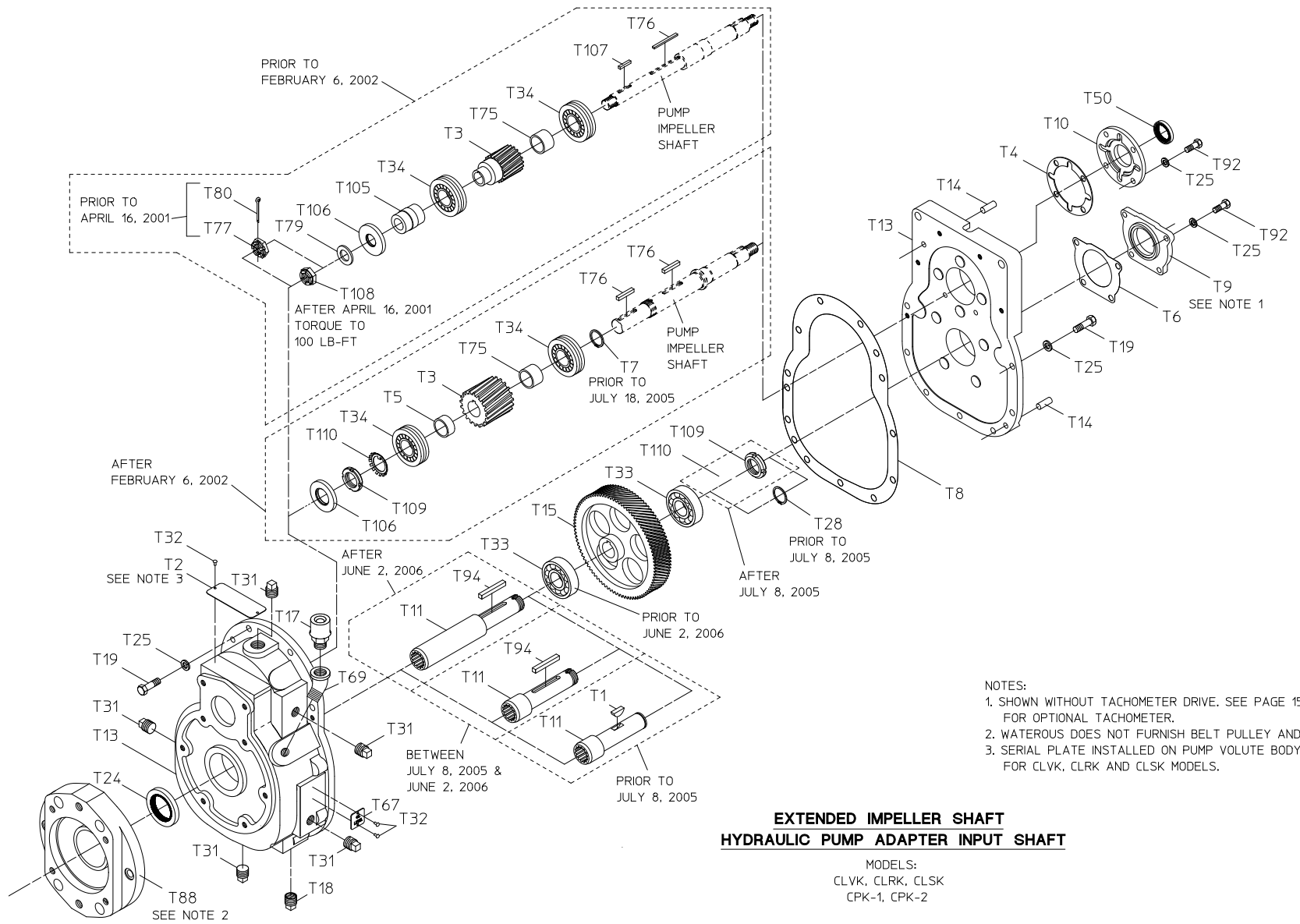

- NOTES:
1. SHOWN WITHOUT TACHOMETER DRIVE. SEE PAGE 15 FOR OPTIONAL TACHOMETER.
 2. WATEROUS DOES NOT FURNISH BELT PULLEY AND SPACER.
 3. SERIAL PLATE INSTALLED ON PUMP VOLUTE BODY FOR CLVK, CLRK AND CLSK MODELS.

**EXTENDED IMPELLER SHAFT
HYDRAULIC PUMP ADAPTER INPUT SHAFT**

MODELS:
CLVK, CLRK, CLSK
CPK-1, CPK-2

**Non-Extended Impeller Shaft
1-1/8 in. Keyed Input Shaft
Models: CPK-3 (Pumps Built After December 1, 1990)**

REF. NO.	DESCRIPTION
T1	Woodruff Key
T2	Serial Plate
T3	Driven Gear
T4	Gasket
T6	Gasket
T8	Gasket
T9	Bearing Cover
T10	Oil Seal Housing
T11	Drive Shaft
T13	Gear Case Subassembly
T14	Dowel Pin, 3/8 x 1 in.
T15	Drive Gear
T17	Breather, 1/2 NPT
T18	Magnetic Drain Plug, 1/2 NPT
T19	Hex Hd Screw, 3/8-16 x 1-1/4 in.
T24	Oil Seal

REF. NO.	DESCRIPTION
T25	Lockwasher, 3/8 in.
T28	Retaining Ring
T31	Pipe Plug, 1/2 NPT
T32	Drive Screw, No. 6 x 1/4 in.
T33	Ball Bearing
T34	Ball Bearing
T50	Oil Seal
T67	Oil Level Plate
T69	Street Elbow, 45 Degree x 1/2 NPT
T75	Bearing Spacer
T76	Square Key
T77	Castle Nut or Nylok Nut
T79	Flat Washer, 3/4 in.
T80	Cotter Pin, 1/8 x 1-1/2 in.
T92	Hex Head Screw, 3/8-16 x 1 in.
T93	Driven Shaft

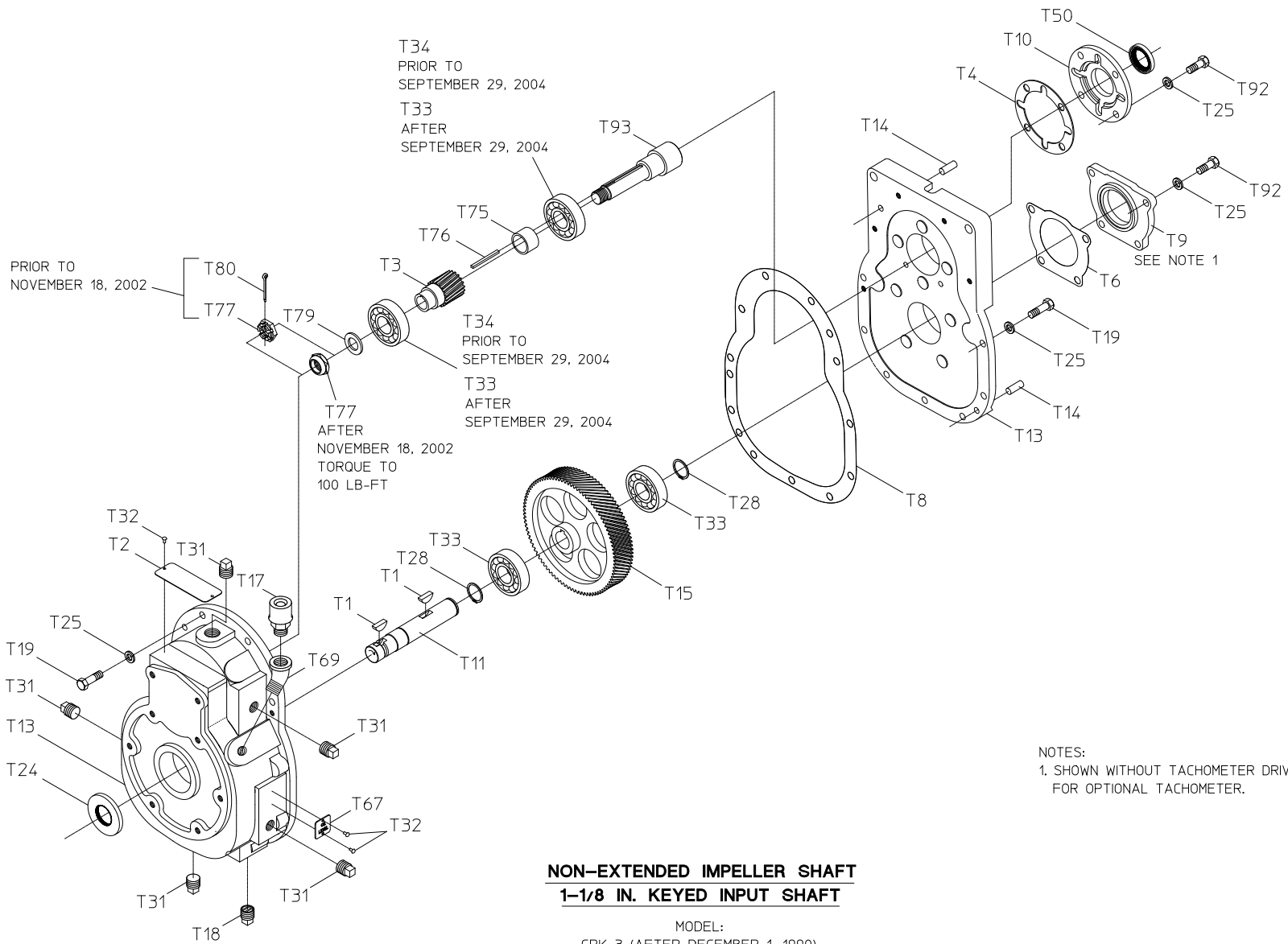

Combination Pumps
Main Pump Models: CM, CMU, CS, CSU, CGG
Combination Pump Models: CPK-1, CPK-2

REF. NO.	DESCRIPTION
T1	Woodruff Key
T2	Serial Plate
T3	Driven Gear
T4	Gasket
T6	Gasket
T8	Gasket
T9	Bearing Cover
T10	Oil Seal Housing
T11	Drive Shaft
T13	Gear Case Subassembly
T14	Dowel Pin, 3/8 x 1 in.
T15	Drive Gear
T17	Breather, 1/2 NPT
T18	Magnetic Drain Plug, 1/2 NPT
T19	Hex Hd Screw, 3/8-16 x 1-1/4 in.
T23	Hex Nut, 1/2-20
T24	Oil Seal
T25	Lockwasher, 3/8 in.
T26	Lockwasher, 7/16 in.
T27	Lockwasher, 1/2 in.

REF. NO.	DESCRIPTION
T28	Retaining Ring
T31	Pipe Plug, 1/2 NPT
T32	Drive Screw, No. 6 x 1/4 in.
T33	Ball Bearing
T34	Ball Bearing
T50	Oil Seal
T67	Oil Level Plate
T75	Bearing Spacer
T76	Square Key
T77	Castle Nut or Nylok Nut
T79	Flat Washer, 3/4 in.
T80	Cotter Pin, 1/8 x 1-1/2 in.
T84	Pipe Nipple, 1/2 x 2-1/2 in.
T85	Elbow, 90 Degree, 1/2 NPT
T87	Adapter Bushing
T89	Gear Case Adapter
T92	Hex Head Screw, 3/8-16 x 1 in.
T103	Hex Head Screw, 1/2 - 13 x 1-1/4 in.
T104	Stud, 1/2-13 x 4-1/4 in.

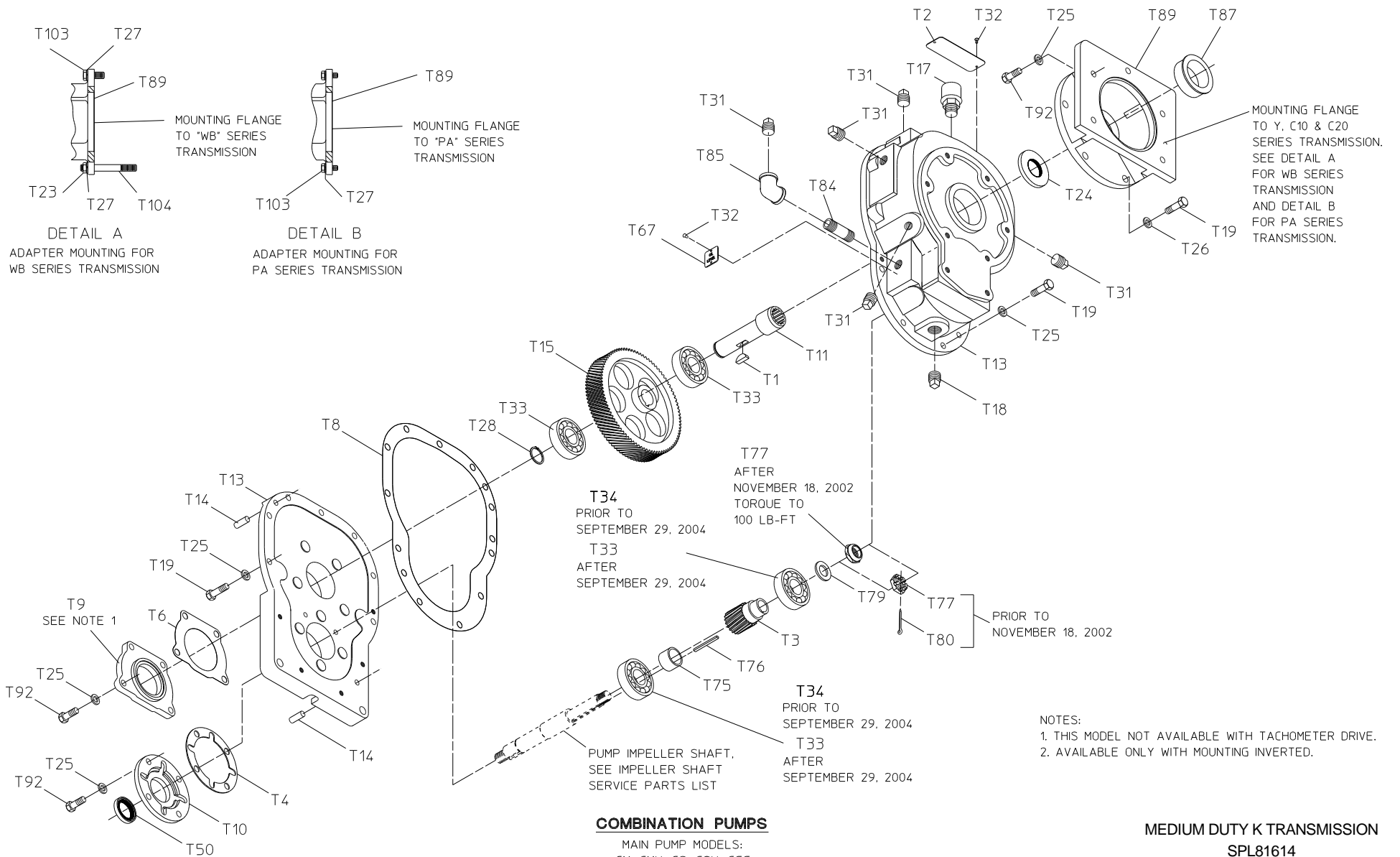

COMBINATION PUMPS

MAIN PUMP MODELS:
CM, CMU, CS, CSU, CGG
COMBINATION PUMP MODELS:
CPK-1, CPK-2

NOTES:
1. THIS MODEL NOT AVAILABLE WITH TACHOMETER DRIVE.
2. AVAILABLE ONLY WITH MOUNTING INVERTED.

MEDIUM DUTY K TRANSMISSION
SPL81614
WATEROUS COMPANY
SOUTH ST. PAUL, MN 55075
PAGE 13 OF 17

**Optional Transmission Input Shaft Tachometer
Transmission Case Mounting to Pump**

REF. NO.	DESCRIPTION
T6	Gasket
T13	Gear Case Subassembly
T20	Hex Head Screw, 7/16-14 x 1-1/4 in.
T21	Hex Head Screw, 1/2-13 x 1-1/2 in.
T22	Hex Head Screw, 1/2-20 x 2-3/4 in.
T23	Hex Nut, 1/2-20
T25	Lockwasher, 3/8 in.
T26	Lockwasher, 7/16 in.
T27	Lockwasher, 1/2 in.
T36	Tachometer Gear Assembly

REF. NO.	DESCRIPTION
T40	Tachometer Housing
T43	Tachometer Driven Gear
T44	Tachometer/Speedometer Sleeve
T45	Tachometer/Speedometer Bushing
T56	Suspension Pin
T57	Suspension Pin Bracket
T59	Cotter Pin, 5/16 x 2-1/2 in.
T73	Spirol Pin, 3/16 in.
T74	Tachometer Gear Pilot Ring
T92	Hex Head Screw, 3/8-16 x 1 in.

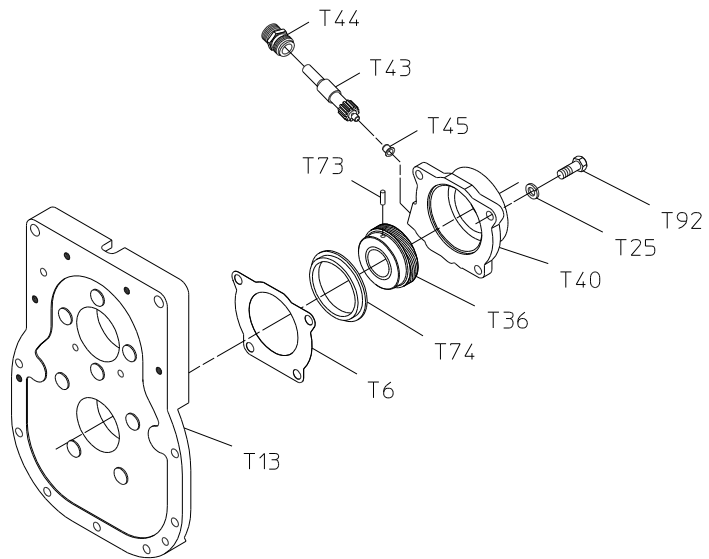

TRANSMISSION INPUT SHAFT
OPTIONAL TACHOMETER DRIVE

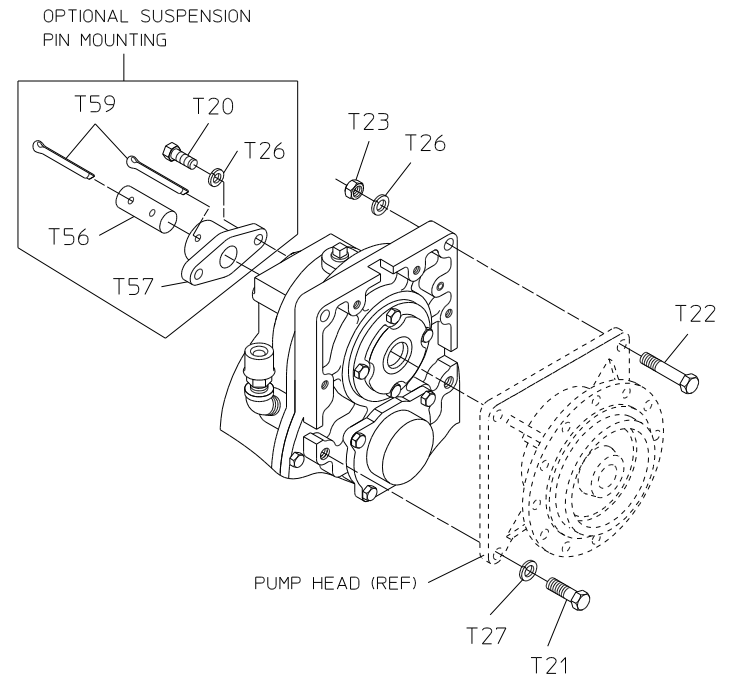

TRANSMISSION CASE
MOUNTING TO PUMP

Transmission Case Mounting Positions

REF. NO.	DESCRIPTION
T17	Breather, 1/2 NPT
T18	Magnetic Drain Plug, 1/2 NPT
T31	Pipe Plug, 1/2 NPT
T32	Drive Screw, No. 6 x 1/4 in.

REF. NO.	DESCRIPTION
T67	Oil Level Plate
T69	Street Elbow, 45 Degree x 1/2 NPT
T84	Pipe Nipple, 1/2 x 2-1/2 in.
T85	Elbow, 90 Degree, 1/2 NPT

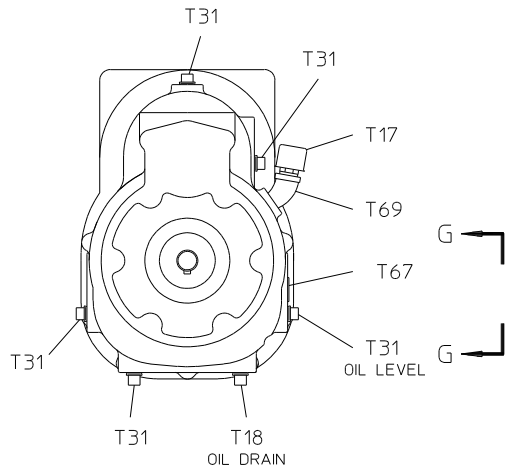

VERTICAL POSITION

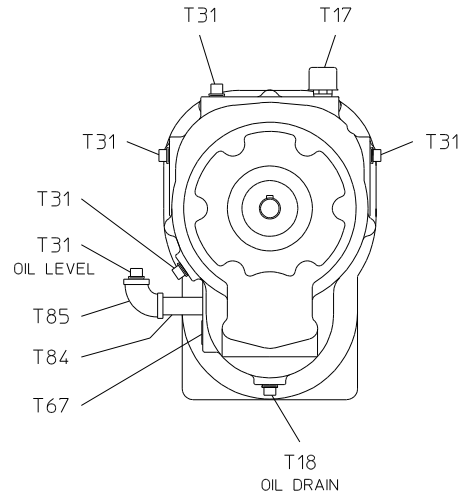

INVERTED POSITION

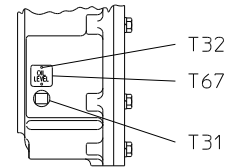

VIEW G-G

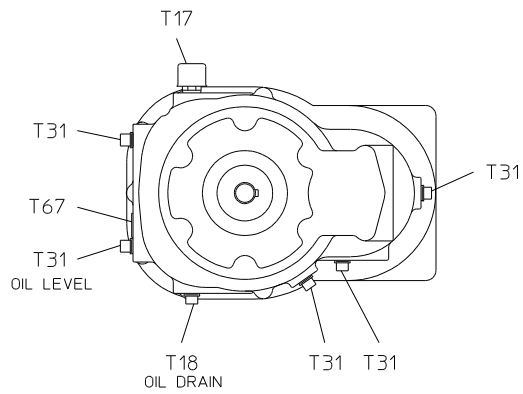

LEFT SIDE POSITION

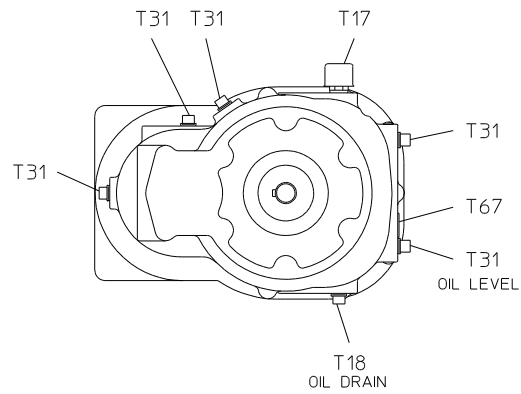

RIGHT SIDE POSITION

TRANSMISSION CASE MOUNTING POSITIONS