



Document Number	Issue Date	Rev. Date
SPL81615	11/15/88	3/26/24

Heavy Duty K Transmission Service Parts List

Index:

Pump		Transmission		See Page				
Series	Model <i>(Located on Serial Plate)</i>	Mounting	Extended Shaft <i>(Compressor Drive)</i>	Case Components	Optional Input <i>(SAE Class C 4-Bolt Hydraulic Adapter)</i>	Pump Mounting Hardware	Transmission Mounting Positions	Optional Oil Cooler
CM, CMH, CS, CSH	CMK, CMHK, CSK, CSHK	Rear of Pump, Vertical	N/A	2, 3	16, 17	18, 19	22, 23	24, 25
		Rear of Pump, Inverted	N/A	4, 5				
		Front of Pump, Inverted 45°	N/A	6, 7				
CG	CGVK, CGNK, CGRK, CGVGK, CGVNK, CGVRK, CGGK	Vertical or Inverted	N/A	8, 9				
		Horizontal (Left) Only	No	10, 11				
CX	CXNK, CXRK, CXVK	Vertical, Horizontal or Inverted	No	12, 13		20, 21		
		Horizontal (Left) Only	Yes	14, 15				

Note: When ordering parts, please supply Pump Serial Number

Case Components, CM & CS Series Pumps, Vertical Mounting

REF. NO.	DESCRIPTION
T2	Serial plate
T3	Driven gear
T4	Gasket
T8	Gasket
T10	Oil seal housing
T11	Drive shaft
T13	Gear case subassembly
T14	Dowel pin, 3/8 x 1 in.
T15	Drive gear
T19	Hex hd screw, 3/8-16 x 1-1/4 in., Grade 5
T24	Oil seal, 1-5/8 x 2-7/16
T25	Lock washer, 3/8 in.
T28	Retaining ring
T29	Square key, 3/8 x 1-3/4 in.
T32	Drive screw, no. 6 x 1/4 in.
T35	Woodruff key, 1/8 x 3/4 in.
T36	Tachometer drive gear
T37	Bearing spacer
T39	Oil seal sleeve

REF. NO.	DESCRIPTION
T40	Tachometer gear housing subassembly (includes T45)
T41	Bearing lock nut
T42	Tachometer plug
T43	Tachometer driven gear
T44	Tachometer/speedometer sleeve
T45	Tachometer/speedometer bushing
T46	Shaft nut, 1-20
T47	Bearing lock washer
T48	Cotter pin, 1/8 x 1-3/4 in. SS
T49	O-ring, 3-1/4 x 3-1/2 in.
T50	Oil seal, 1-5/8 x 2-3/4 or 1-7/8 x 2-3/4 in.
T51	Retaining ring
T52	Ball bearing
T53	Ball bearing
T54	Ball bearing
T92	Hex hd screw, 3/8-16 x 1 in.
T96	Driven shaft
T98	Flinger V-ring (used prior to 8/26/93) Sealing boot (used after 8/26/93)
T99	Square key, 5/16 x 1-9/16 in.

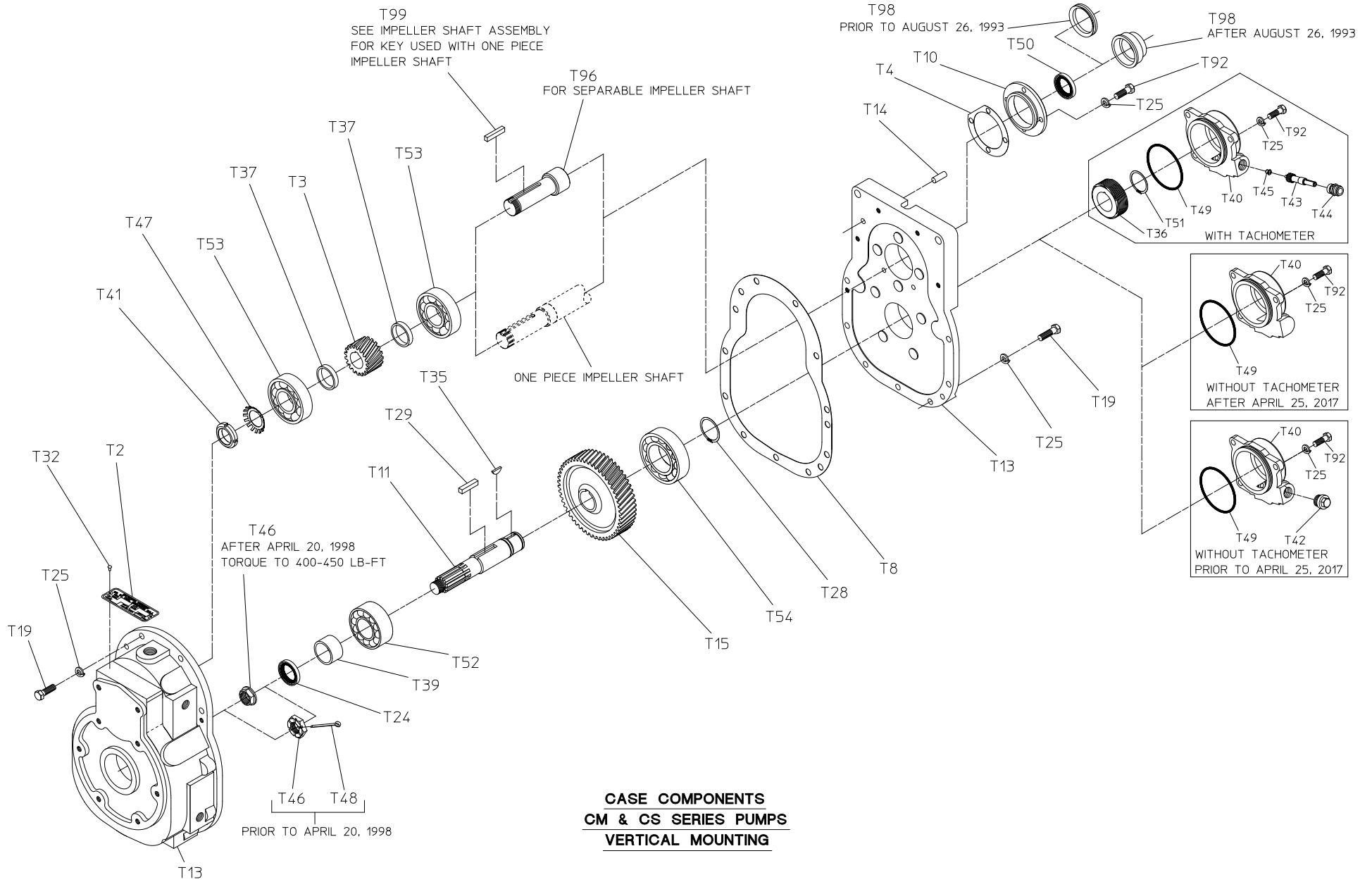

Case Components, CM & CS Series Pumps, Inverted Mounting

REF. NO.	DESCRIPTION
T3	Driven gear
T4	Gasket
T8	Gasket
T10	Oil seal housing
T11	Drive shaft
T13	Gear case subassembly
T14	Dowel pin, 3/8 x 1 in.
T15	Drive gear
T19	Hex hd screw, 3/8-16 x 1-1/4 in., Grade 5
T24	Oil seal, 1-5/8 x 2-7/16
T25	Lock washer, 3/8 in.
T28	Retaining ring
T29	Square key, 3/8 x 1-3/4 in.
T35	Woodruff key, 1/8 x 3/4 in.
T36	Tachometer drive gear
T37	Bearing spacer
T39	Oil seal sleeve
T40	Tachometer gear housing subassembly (includes T45)
T41	Bearing lock nut

REF. NO.	DESCRIPTION
T42	Tachometer plug
T43	Tachometer driven gear
T44	Tachometer/speedometer sleeve
T45	Tachometer/speedometer bushing
T46	Shaft nut, 1-20
T47	Bearing lock washer
T48	Cotter pin, 1/8 x 1-3/4 in. SS
T49	O-ring, 3-1/4 x 3-1/2 in.
T50	Oil seal, 1-5/8 x 2-3/4 or 1-7/8 x 2-3/4 in.
T51	Retaining ring
T52	Ball bearing
T53	Ball bearing
T54	Ball bearing
T82	Hex hd screw, 3/8-24 x 1-1/2 in. zinc plated
T83	Hex nut, 3/8-24
T92	Hex hd screw, 3/8-16 x 1 in.
T96	Driven shaft
T98	Flinger V-ring (used prior to 8/26/93) Sealing boot (used after 8/26/93)
T99	Square key, 5/16 x 1-9/16 in.

Case Components, CM & CS Series Pumps, Inverted 45° Mounting

REF. NO.	DESCRIPTION
T3	Driven gear
T4	Gasket
T8	Gasket
T11	Drive shaft
T13	Gear case subassembly
T14	Dowel pin, 3/8 x 1 in.
T15	Drive gear
T19	Hex hd screw, 3/8-16 x 1-1/4 in., Grade 5
T21	Hex hd screw, 1/2-13 x 1-1/2 or 1-1/4 in. Grade 5
T22	Hex hd screw, 1/2-20 x 2-1/2 in., Grade 5, zinc plated
T23	Hex nut, 1/2-20
T24	Oil seal, 1-5/8 x 2-7/16
T25	Lock washer, 3/8 in.
T27	Lock washer, 1/2 in.
T28	Retaining ring
T29	Square key, 3/8 x 1-3/4 in.
T35	Woodruff key, 1/8 x 3/4 in.
T36	Tachometer drive gear
T37	Bearing spacer
T38	Bearing spacer

REF. NO.	DESCRIPTION
T39	Oil seal sleeve
T40	Tachometer gear housing subassembly (includes T45)
T41	Bearing lock nut
T42	Tachometer plug
T43	Tachometer driven gear
T44	Tachometer/speedometer sleeve
T45	Tachometer/speedometer bushing
T46	Shaft nut, 1-20
T47	Bearing lock washer
T48	Cotter pin, 1/8 x 1-3/4 in. SS
T49	O-ring, 3-1/4 x 3-1/2 in.
T50	Oil seal, 1-5/8 x 2-1/2
T51	Retaining ring
T52	Ball bearing
T53	Ball bearing
T54	Ball bearing
T68	Gear case adapter
T82	Hex hd screw, 3/8-24 x 1-1/2 in. zinc plated
T83	Hex nut, 3/8-24
T92	Hex hd screw, 3/8-16 x 1 in.

Case Components, CG Series Pumps, Vertical, Horizontal or Inverted Mounting

REF. NO.	DESCRIPTION
T2	Serial plate
T3	Driven gear
T4	Gasket
T8	Gasket
T10	Oil seal housing
T11	Drive shaft
T13	Gear case subassembly
T14	Dowel pin, 3/8 x 1 in.
T15	Drive gear
T19	Hex hd screw, 3/8-16 x 1-1/4 in., Grade 5
T24	Oil seal, 1-5/8 x 2-7/16
T25	Lock washer, 3/8 in.
T28	Retaining ring
T29	Square key, 3/8 x 1-3/4 in.
T32	Drive screw, no. 6 x 1/4 in.
T35	Woodruff key, 1/8 x 3/4 in.
T36	Tachometer drive gear
T37	Bearing spacer

REF. NO.	DESCRIPTION
T38	Bearing spacer
T39	Oil seal sleeve
T40	Tachometer gear housing subassembly (includes T45)
T41	Bearing lock nut
T42	Tachometer plug
T43	Tachometer driven gear
T44	Tachometer/speedometer sleeve
T45	Tachometer/speedometer bushing
T46	Shaft nut, 1-20
T47	Bearing lock washer
T48	Cotter pin, 1/8 x 1-3/4 in. SS
T49	O-ring, 3-1/4 x 3-1/2 in.
T50	Oil seal, 1-5/8 x 2-1/2
T51	Retaining ring
T52	Ball bearing
T53	Ball bearing
T54	Ball bearing
T92	Hex hd screw, 3/8-16 x 1 in.

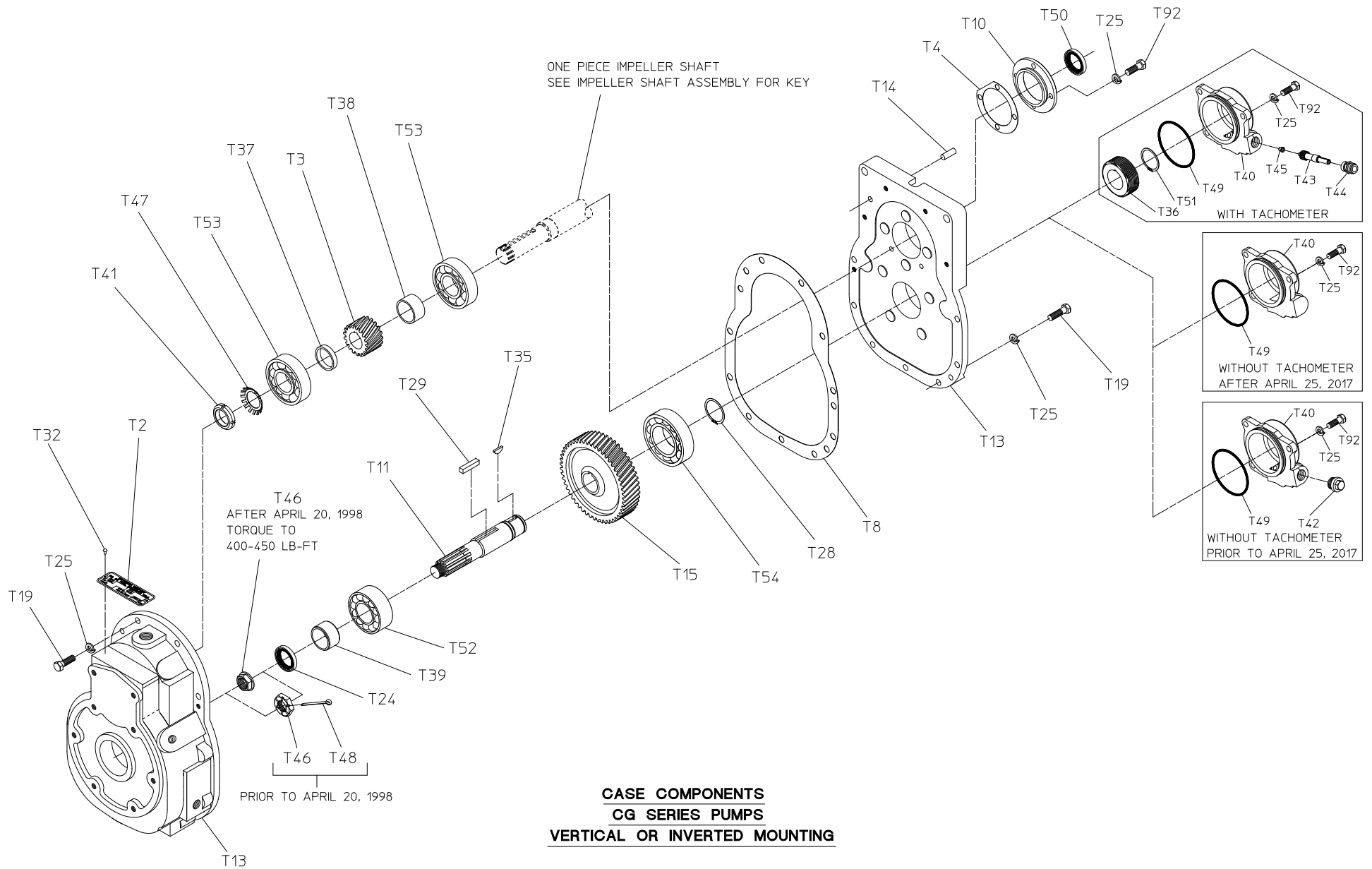

Case Components, CG Series Pumps, Horizontal Mounting

REF. NO.	DESCRIPTION
T2	Serial plate
T3	Driven gear
T4	Gasket
T8	Gasket
T10	Oil seal housing
T11	Drive shaft
T13	Gear case subassembly
T14	Dowel pin, 3/8 x 1 in.
T15	Drive gear
T19	Hex hd screw, 3/8-16 x 1-1/4 in., Grade 5
T24	Oil seal, 1-5/8 x 2-7/16
T25	Lock washer, 3/8 in.
T28	Retaining ring
T29	Square key, 3/8 x 1-3/4 in.
T32	Drive screw, no. 6 x 1/4 in.
T37	Bearing spacer

REF. NO.	DESCRIPTION
T38	Bearing spacer
T39	Oil seal sleeve
T40	Disc Cover
T41	Bearing lock nut
T46	Shaft nut, 1-20
T47	Bearing lock washer
T49	O-ring, 3-1/4 x 3-1/2 in.
T50	Oil seal, 1-5/8 x 2-1/2
T52	Ball bearing
T53	Ball bearing
T54	Ball bearing
T92	Hex hd screw, 3/8-16 x 1 in.

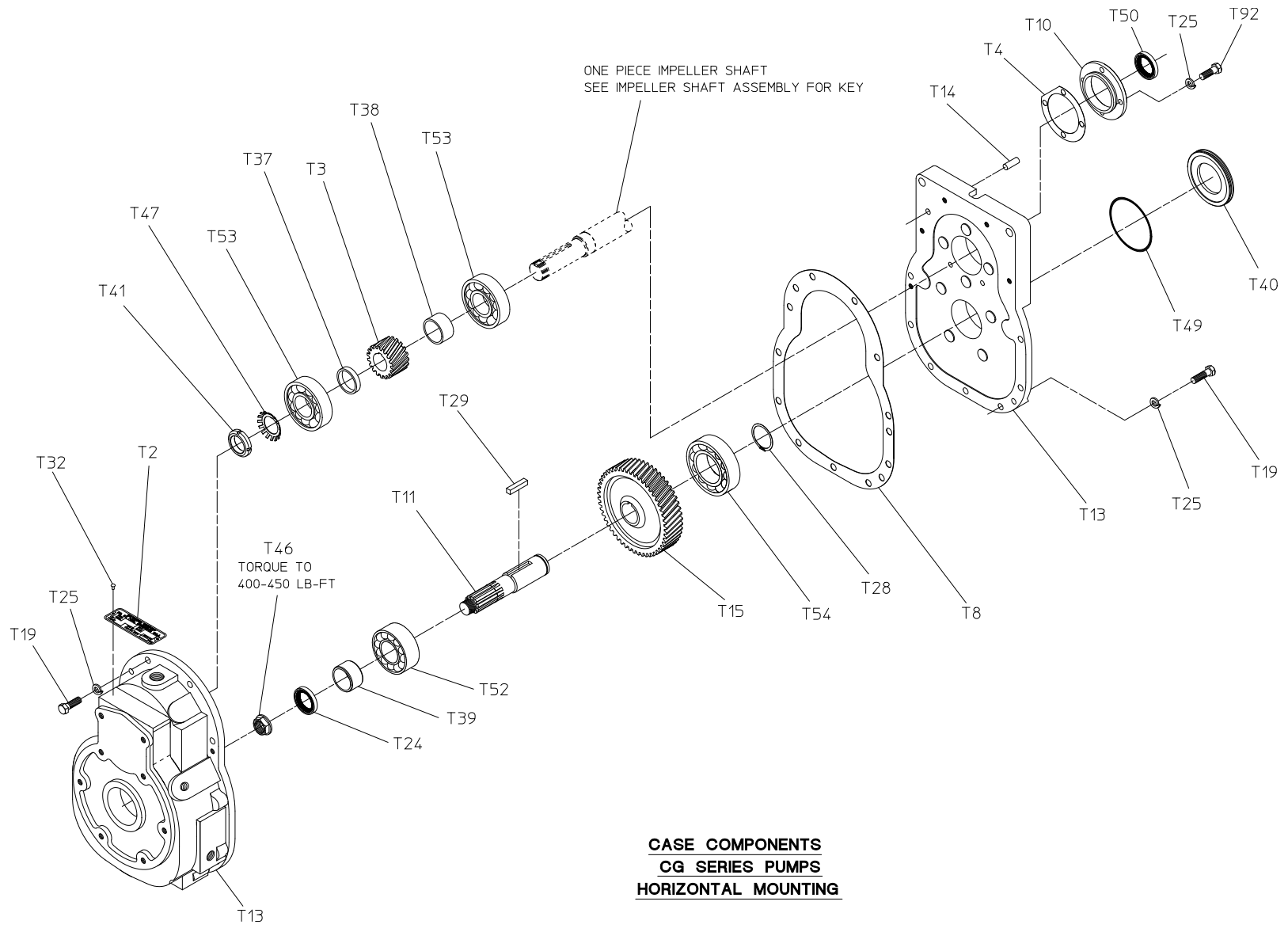

Case Components, CX Series Pumps, Vertical, Horizontal or Inverted (Without Extended Shaft)

REF. NO.	DESCRIPTION
T2	Serial plate
T3	Driven gear
T4	Gasket
T8	Gasket
T10	Oil seal housing
T11	Drive shaft
T13	Gear case subassembly
T14	Dowel pin, 3/8 x 1 in.
T15	Drive gear
T19	Hex hd screw, 3/8-16 x 1-1/4 in., Grade 5
T24	Oil seal, 1-5/8 x 2-7/16
T25	Lock washer, 3/8 in.
T28	Retaining ring
T29	Square key, 3/8 x 1-3/4 in.
T32	Drive screw, no. 6 x 1/4 in.
T35	Woodruff key, 1/8 x 3/4 in.
T36	Tachometer drive gear
T37	Bearing spacer

REF. NO.	DESCRIPTION
T39	Oil seal sleeve
T40	Tachometer gear housing subassembly (includes T45)
T41	Bearing lock nut
T42	Tachometer plug
T43	Tachometer driven gear
T44	Tachometer/speedometer sleeve
T45	Tachometer/speedometer bushing
T46	Shaft nut, 1-20
T47	Bearing lock washer
T48	Cotter pin, 1/8 x 1-3/4 in. SS
T49	O-ring, 3-1/4 x 3-1/2 in.
T50	Oil seal, 1-5/8 x 2-1/2
T51	Retaining ring
T52	Ball bearing
T53	Ball bearing
T54	Ball bearing
T92	Hex hd screw, 3/8-16 x 1 in.
T93	Ball bearing

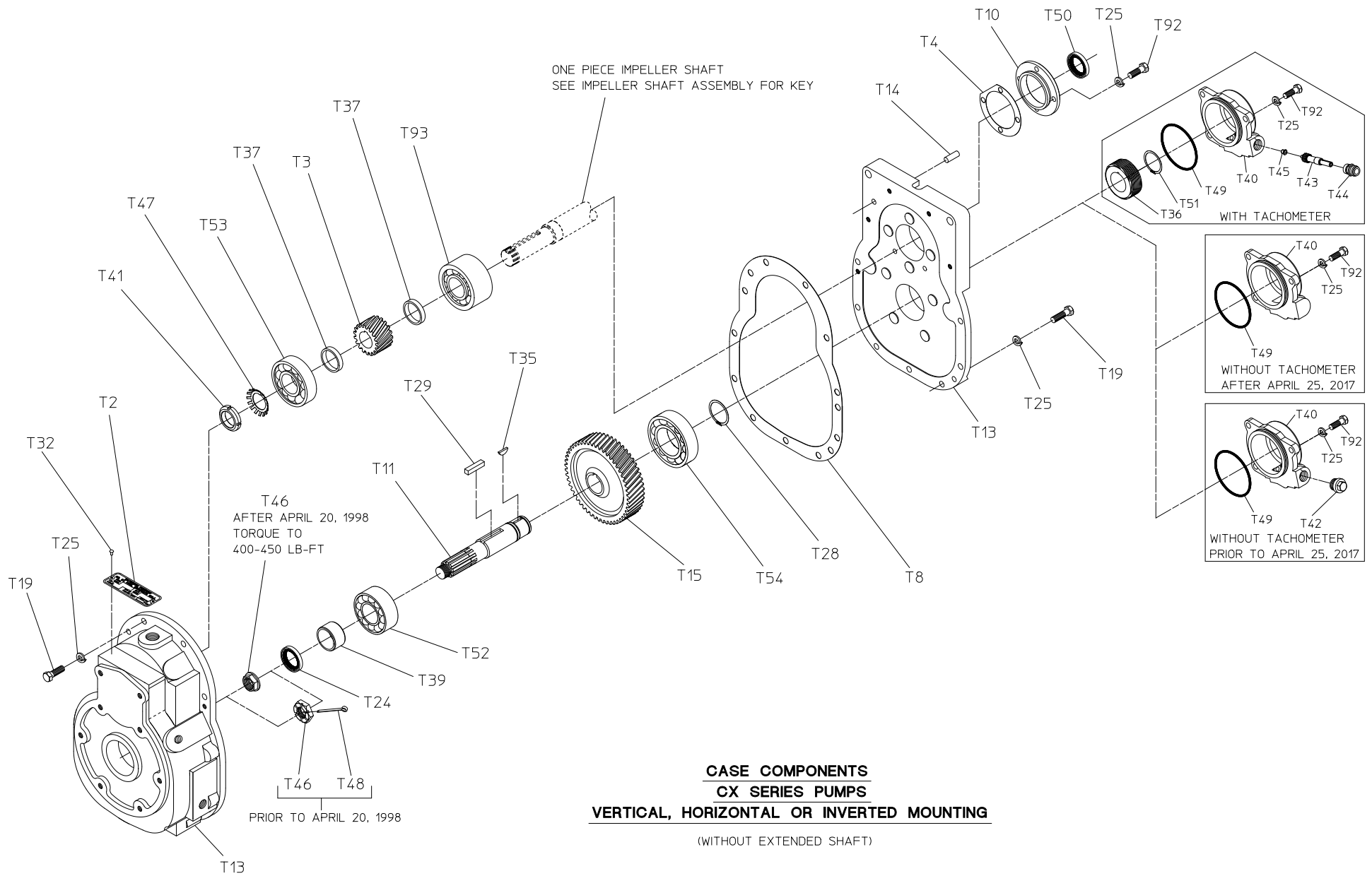

Case Components, CX Series Pumps, Horizontal (Left) Mouting with Extended Shaft

REF. NO.	DESCRIPTION
T2	Serial plate
T3	Driven gear
T4	Gasket
T8	Gasket
T10	Oil seal housing
T11	Drive shaft
T13	Gear case subassembly
T14	Dowel pin, 3/8 x 1 in.
T15	Drive gear
T19	Hex hd screw, 3/8-16 x 1-1/4 in., Grade 5
T24	Oil seal, 1-5/8 x 2-7/16
T25	Lock washer, 3/8 in.
T28	Retaining ring
T29	Square key, 3/8 x 1-3/4 in.
T32	Drive screw, no. 6 x 1/4 in.
T35	Woodruff key, 1/8 x 3/4 in.
T36	Tachometer drive gear
T37	Bearing spacer

REF. NO.	DESCRIPTION
T39	Oil seal sleeve
T40	Tachometer gear housing subassembly (includes T45)
T41	Bearing lock nut
T42	Tachometer plug
T43	Tachometer driven gear
T44	Tachometer/speedometer sleeve
T45	Tachometer/speedometer bushing
T46	Shaft nut, 1-20
T47	Bearing lock washer
T49	O-ring, 3-1/4 x 3-1/2 in.
T50	Oil seal, 1-5/8 x 2-1/2
T51	Retaining ring
T52	Ball bearing
T53	Ball bearing
T54	Ball bearing
T92	Hex hd screw, 3/8-16 x 1 in.
T93	Ball bearing
T100	Oil seal, 1-1/4 x 2 in.
T101	Shaft spacer

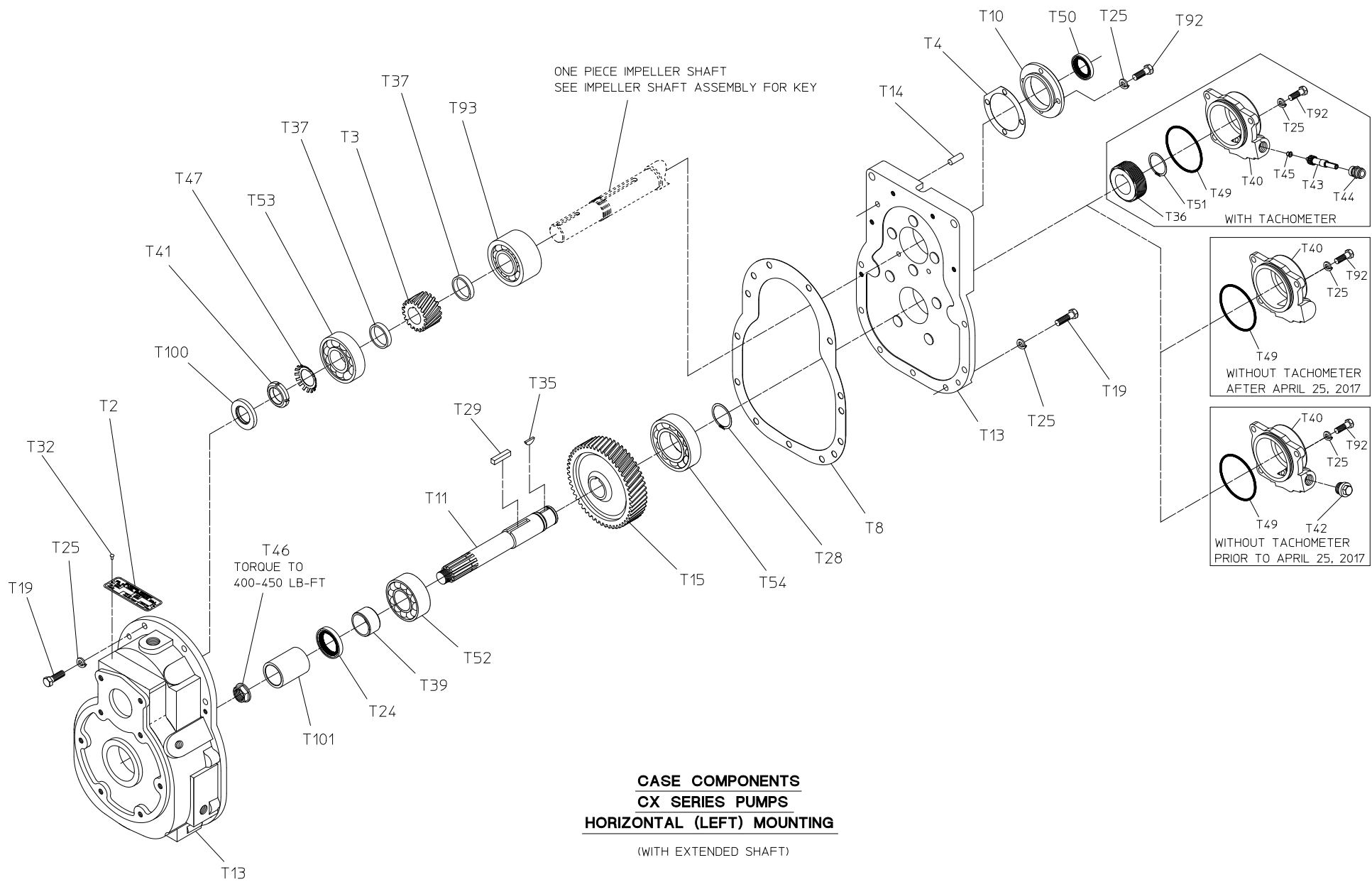

Optional SAE Class C Hydraulic Mounting Flange Input

REF. NO.	DESCRIPTION
T11	Drive shaft
T13	Gear case subassembly
T24	Oil seal, 1-5/8 x 2-7/16
T29	Square key, 3/8 x 1-3/4 in.

REF. NO.	DESCRIPTION
T87	Adapter bushing
T88	Hydraulic motor adapter
T91	Socket hd screw, 7/16-14 x 1-1/4 in.

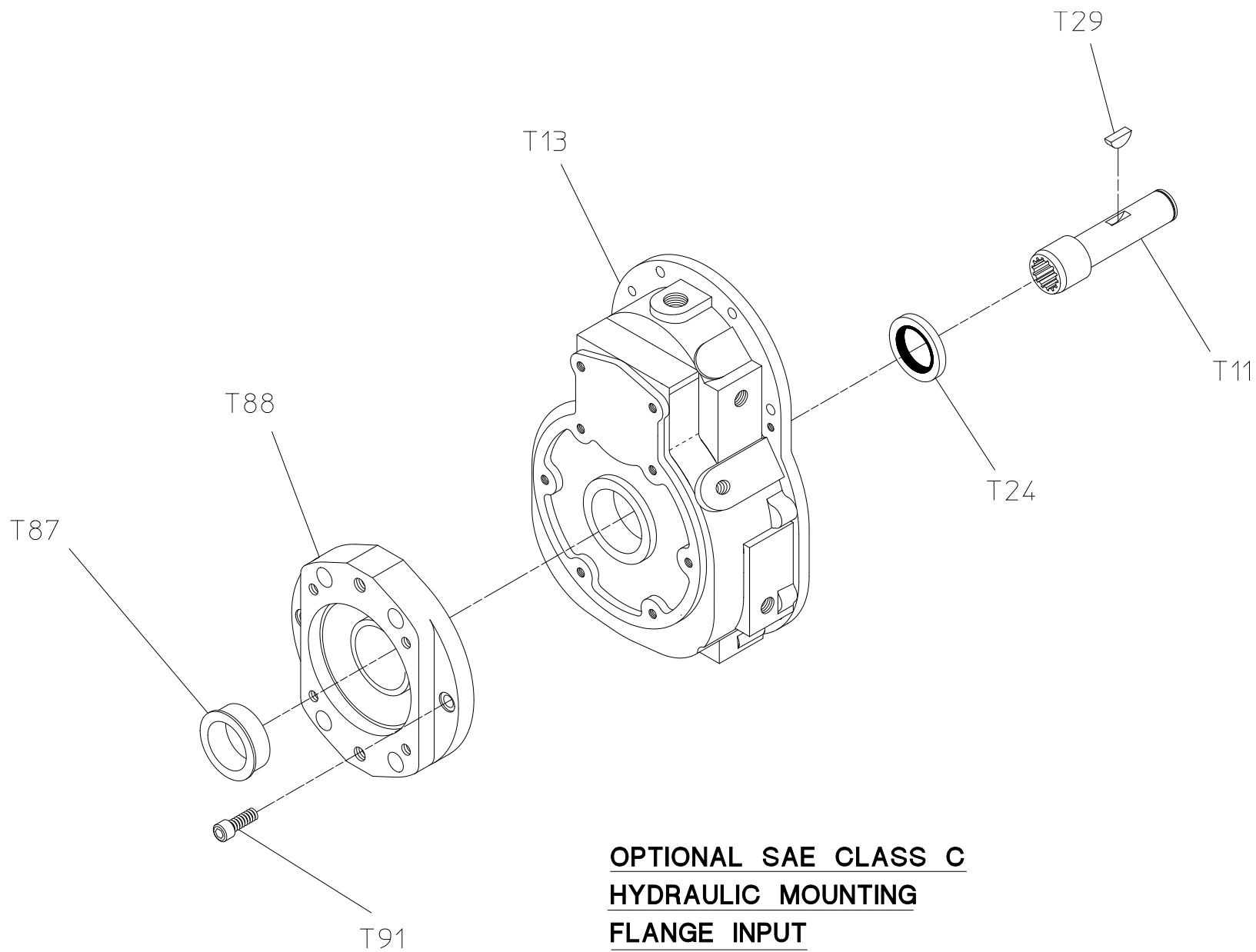

OPTIONAL SAE CLASS C
HYDRAULIC MOUNTING
FLANGE INPUT

Pump Mounting Hardware (CM, CS, CG)

REF. NO.	DESCRIPTION
T20	Hex hd screw, 7/16-14 x 1-1/4 in., Grade 5
T21	Hex hd screw, 1/2-13 x 1-1/2 or 1-1/4 in., Grade 5
T22	Hex hd screw, 1/2-20 x 2-3/4 in., Grade 5
T23	Hex nut, 1/2-20
T26	Lock washer, 7/16 in.
T27	Lock washer, 1/2 in.

REF. NO.	DESCRIPTION
T56	Suspension pin, 1 x 2-5/8 in.
T57	Suspension bracket
T59	Cotter pin, 5/16 x 2-1/2 in.

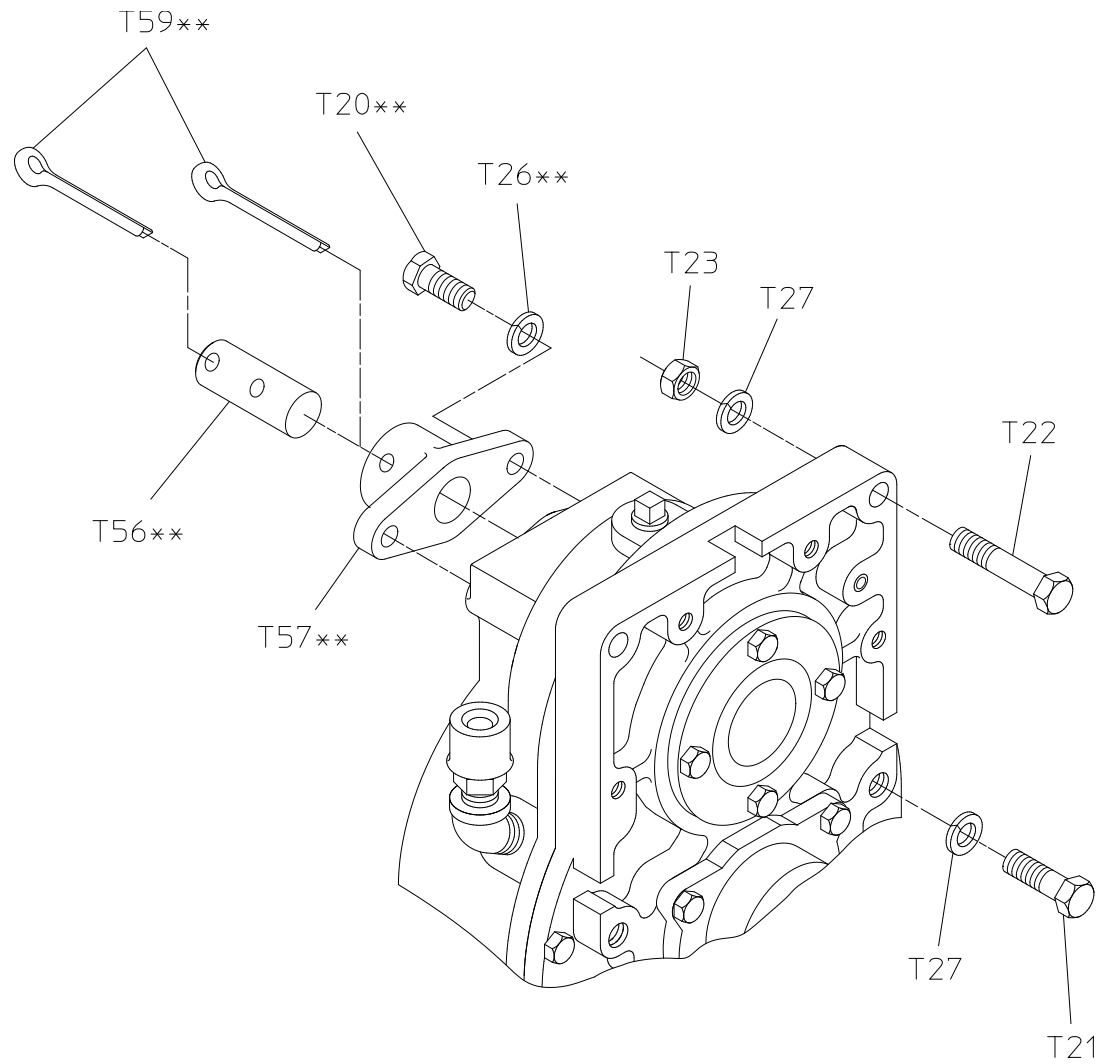

PUMP MOUNTING HARDWARE (CM, CS, CG)

** COMPRISES OPTIONAL GEAR CASE (SUSPENSION PIN)
MOUNTING KIT

Pump Mounting Hardware (CX)

REF. NO.	DESCRIPTION
T20	Hex hd screw, 7/16-14 x 1-1/4 in., Grade 5
T21	Hex hd screw, 1/2-13 x 1-1/2 or 1-1/4 in., Grade 5
T22	Hex hd screw, 1/2-20 x 2-3/4 in., Grade 5
T23	Hex nut, 1/2-20
T26	Lock washer, 7/16 in.
T27	Lock washer, 1/2 in.

REF. NO.	DESCRIPTION
T56	Suspension pin, 1 x 2-5/8 in.
T57	Suspension bracket
T59	Cotter pin, 5/16 x 2-1/2 in.
T124	Stud, 1/2-13 x 2-1/4 in. Grade 5
T125	Hex hd screw, 1/2-13 x 2-3/4 in. Grade 5
T126	Hex nut, 1/2-13

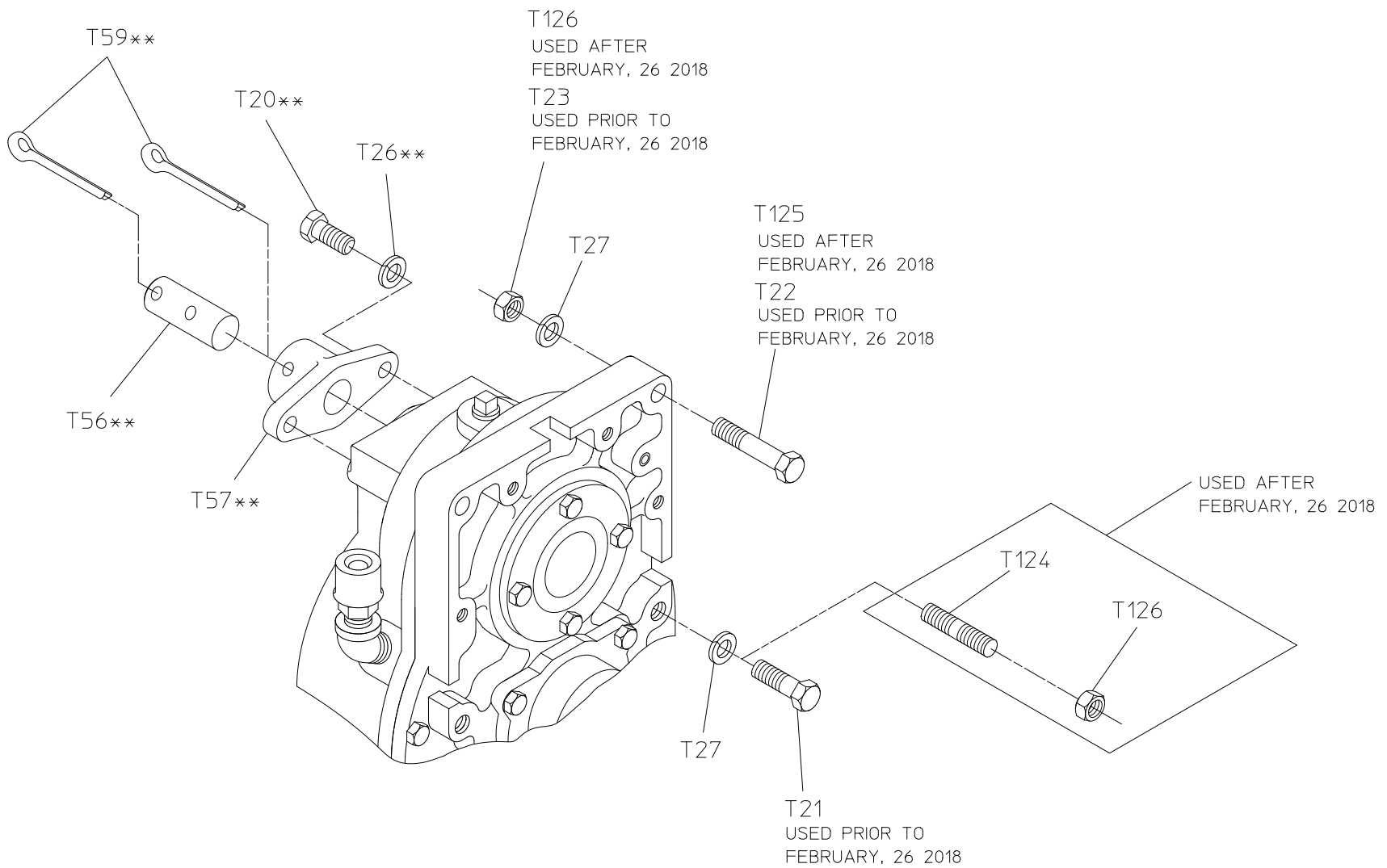

PUMP MOUNTING HARDWARE (CX)

** COMPRISES OPTIONAL GEAR CASE (SUSPENSION PIN)
MOUNTING KIT

Transmission Mounting Positions

REF. NO.	DESCRIPTION
T2	Serial plate
T17	Breather, 1/2 NPT
T18	Magnetic drain plug, 1/2 NPT
T31	Pipe plug, 1/2 NPT, steel
T32	Drive screw, no. 6 x 1/4 in.

REF. NO.	DESCRIPTION
T67	Oil level plate
T69	Street elbow, 45° x 1/2 NPT
T84	Pipe nipple, 1/2 x 2-1/2 in.
T85	Elbow, 90° x 1/2 NPT
T86	Pipe plug, 1/4 in., steel

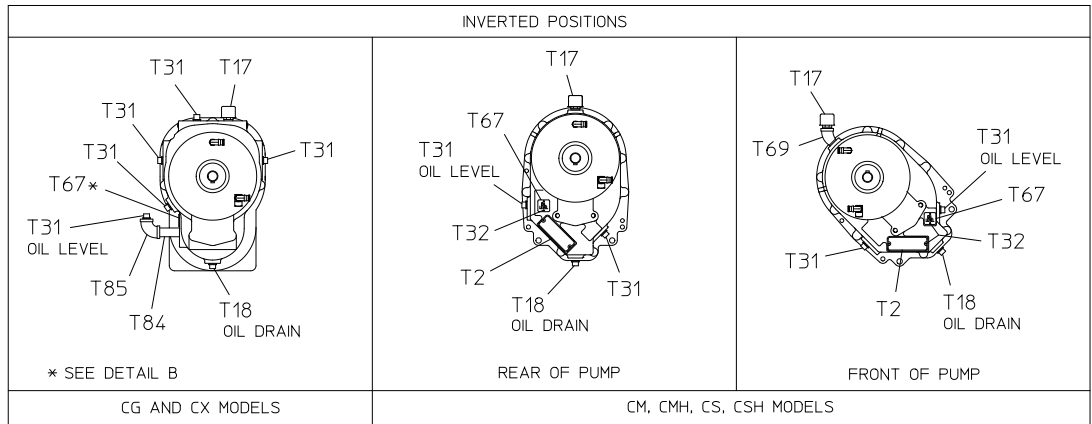
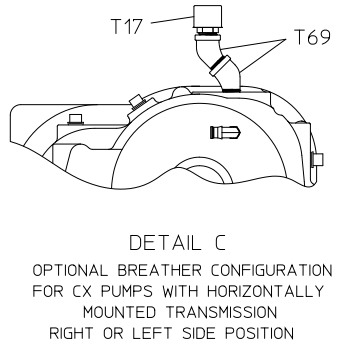
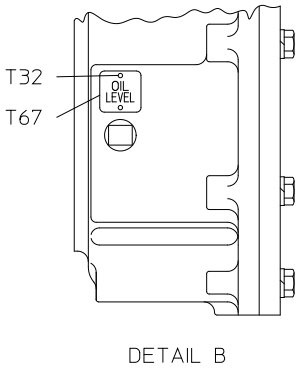
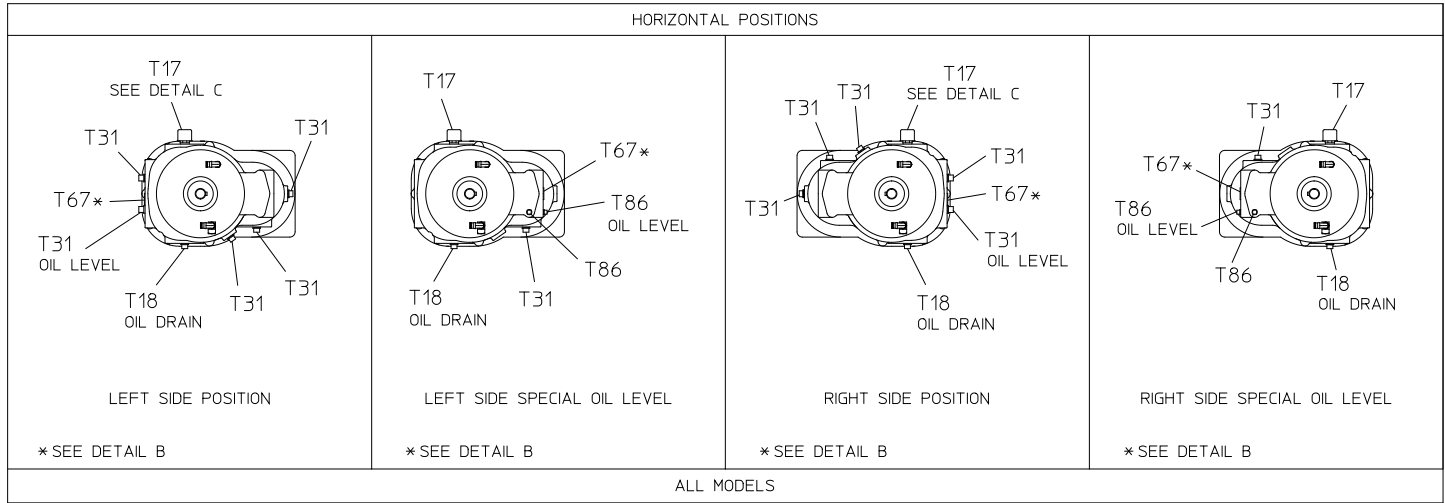
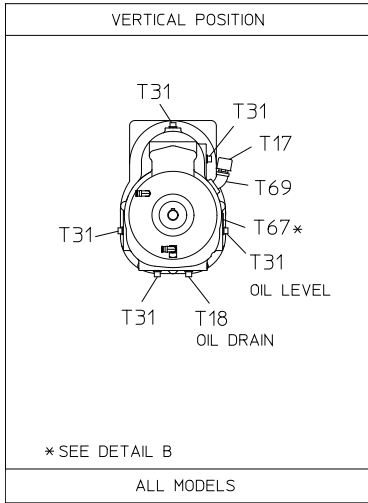

TRANSMISSION MOUNTING POSITIONS

Optional Oil Cooler CG & CX Series Pumps

REF. NO.	DESCRIPTION
T113	Cooling Plate
T114	Cooling Plate Gasket
T115	Hex Head Screw, 7/16-14 x 1-1/2 in.
T116	Lock Washer, 7/16 in.
T117	Socket Head Screw, 7/16-14 x 7/8 in.
T118	O-ring, 2-3/4 x 3 in.

REF. NO.	DESCRIPTION
T120	Green Tubing, 3/8 x 24 in.
T121	90 Degree Elbow, 3/8 PTC x 3/8 NPT or Adapter, 3/8 PTC x 3/8 NPT
T122	90 Degree Elbow, 3/8 PTC x 1/4 NPT
T123	Street Tee, 1/4 NPT
T127	90 Degree Elbow, 3/8 PTC x 3/8 NPT

