

Issued: 9/92
Revised: 12/10/97

W A T E R O U S

WATEROUS COMPANY
SOUTH ST. PAUL, MINNESOTA

Impeller Shaft Assembly, CP-3-500

REF NO.	DESCRIPTION	REF NO.	DESCRIPTION
---------	-------------	---------	-------------

Index:

Impeller Arrangement	See Page
High Capacity	2
High Pressure	3
Medium Capacity	4
Exploded Parts View for Part Identification	5

S1	Impeller Shaft	S8	Wear ring
S2	Retaining ring	S9	Wear ring
S3	Ball bearing	S10	Impeller, second stage
S4	Flinger ring	S11	Impeller, first stage
S5	Retaining ring	S14	Mechanical seal replacement kit (outboard end)
S6	Retaining ring	S15	Mechanical seal replacement kit (drive end)
S7	Square key, 1/4 x 1/4 x 1 in.		

PLEASE NOTE

WHEN ORDERING PARTS PLEASE SUPPLY PUMP SERIAL NUMBER

SPL81749

PAGE 1 OF 5

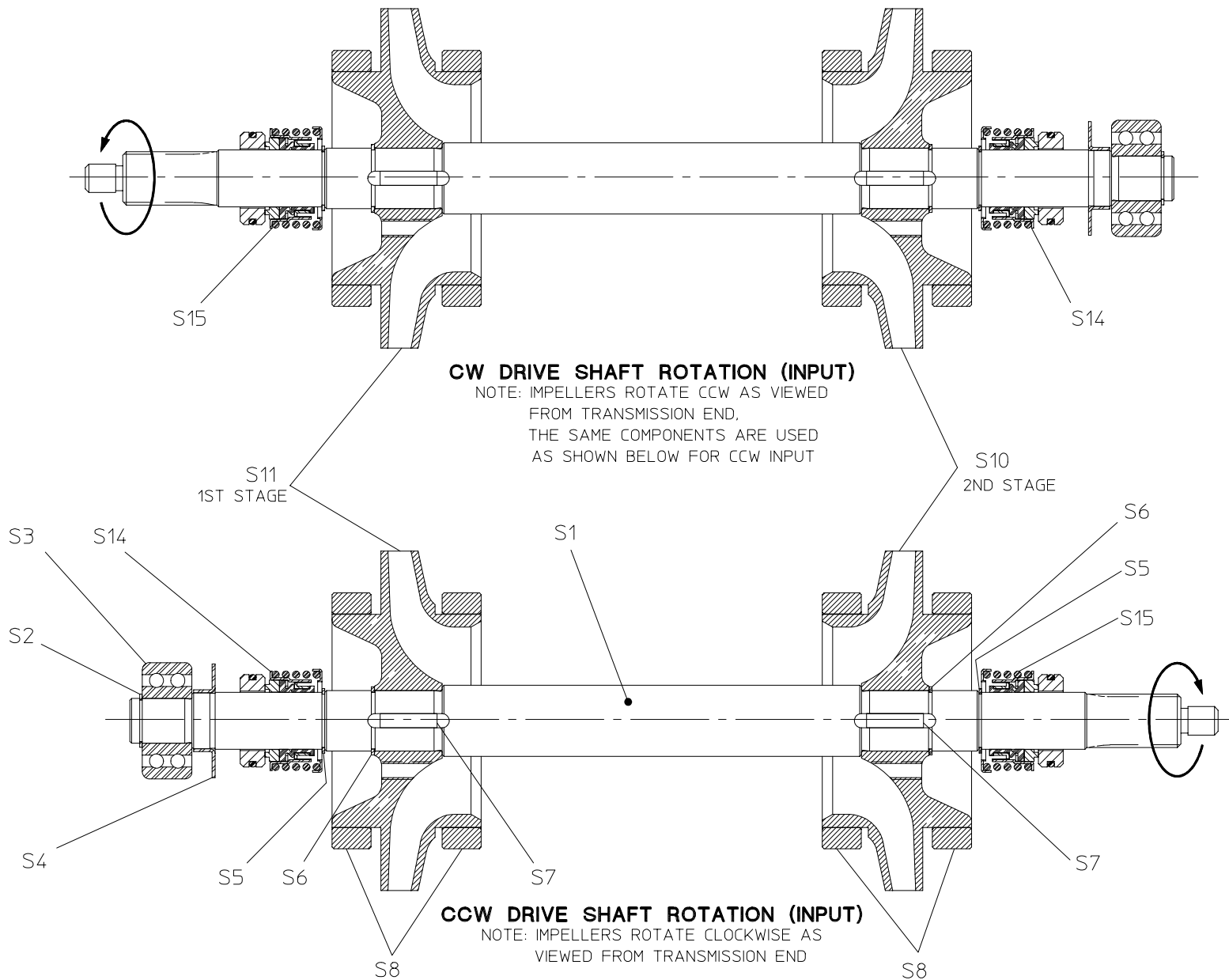

HIGH CAPACITY IMPELLER ARRANGEMENT

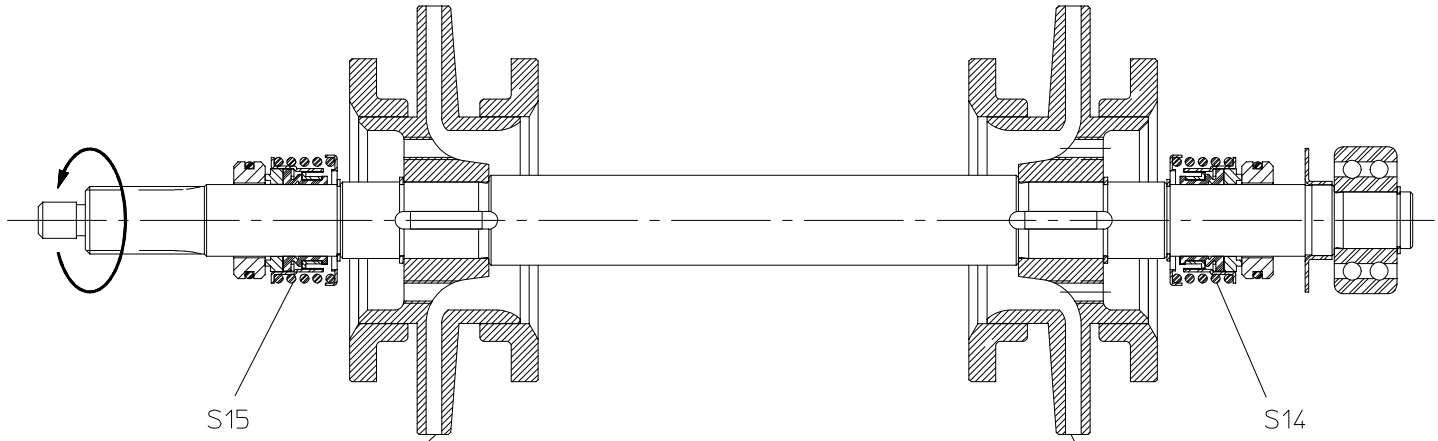

CW DRIVE SHAFT ROTATION (INPUT)

NOTE: IMPELLERS ROTATE CCW AS VIEWED FROM TRANSMISSION END, THE SAME COMPONENTS ARE USED AS SHOWN BELOW FOR CCW INPUT

S11
1ST STAGE

S10
2ND STAGE

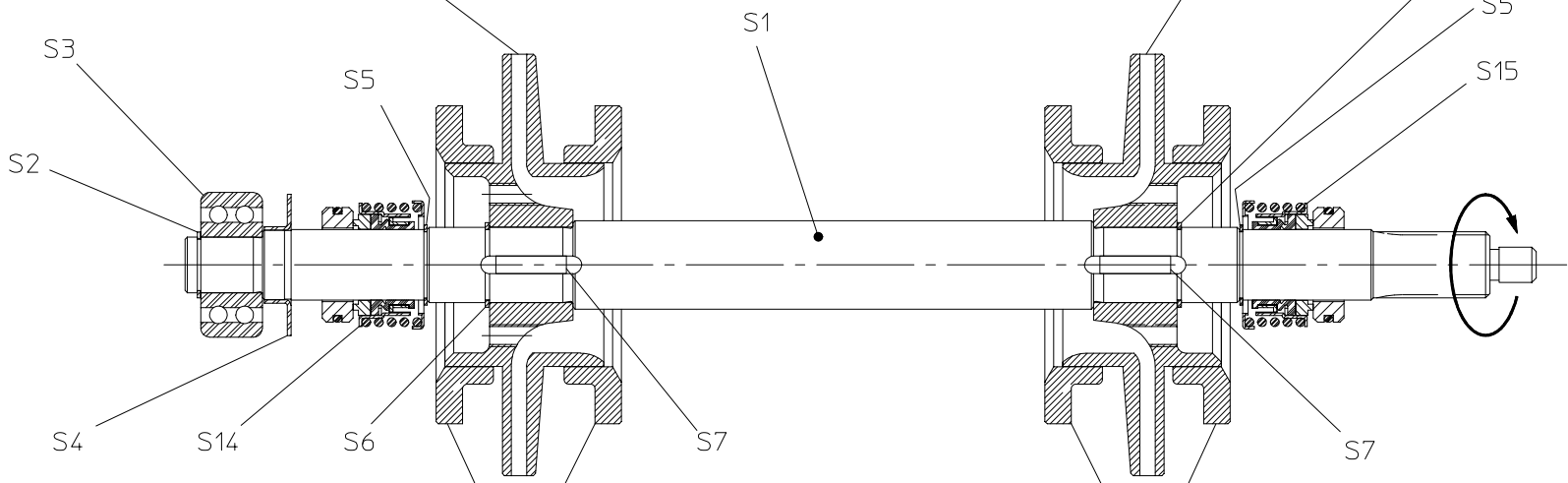

CCW DRIVE SHAFT ROTATION (INPUT)

NOTE: IMPELLERS ROTATE CLOCKWISE AS VIEWED FROM TRANSMISSION END

HIGH PRESSURE IMPELLER ARRANGEMENT

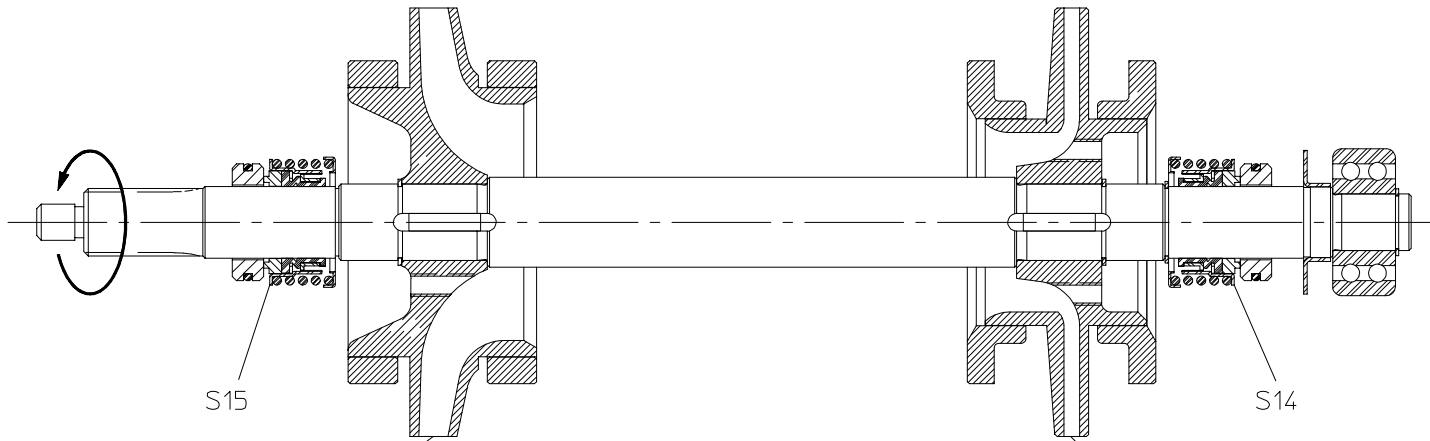

CW DRIVE SHAFT ROTATION (INPUT)

NOTE: IMPELLERS ROTATE CCW AS VIEWED FROM TRANSMISSION END, THE SAME COMPONENTS ARE USED AS SHOWN BELOW FOR CCW INPUT

S11
1ST STAGE

S10
2ND STAGE

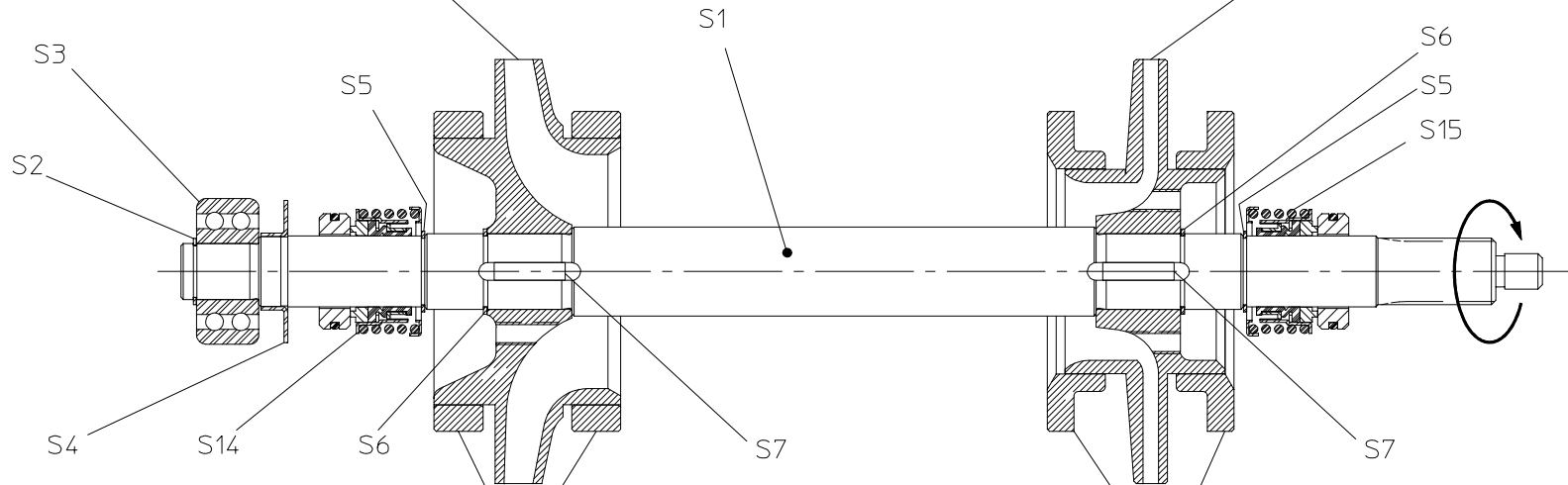

CCW DRIVE SHAFT ROTATION (INPUT)

NOTE: IMPELLERS ROTATE CLOCKWISE AS VIEWED FROM TRANSMISSION END

MEDIUM CAPACITY IMPELLER ARRANGEMENT

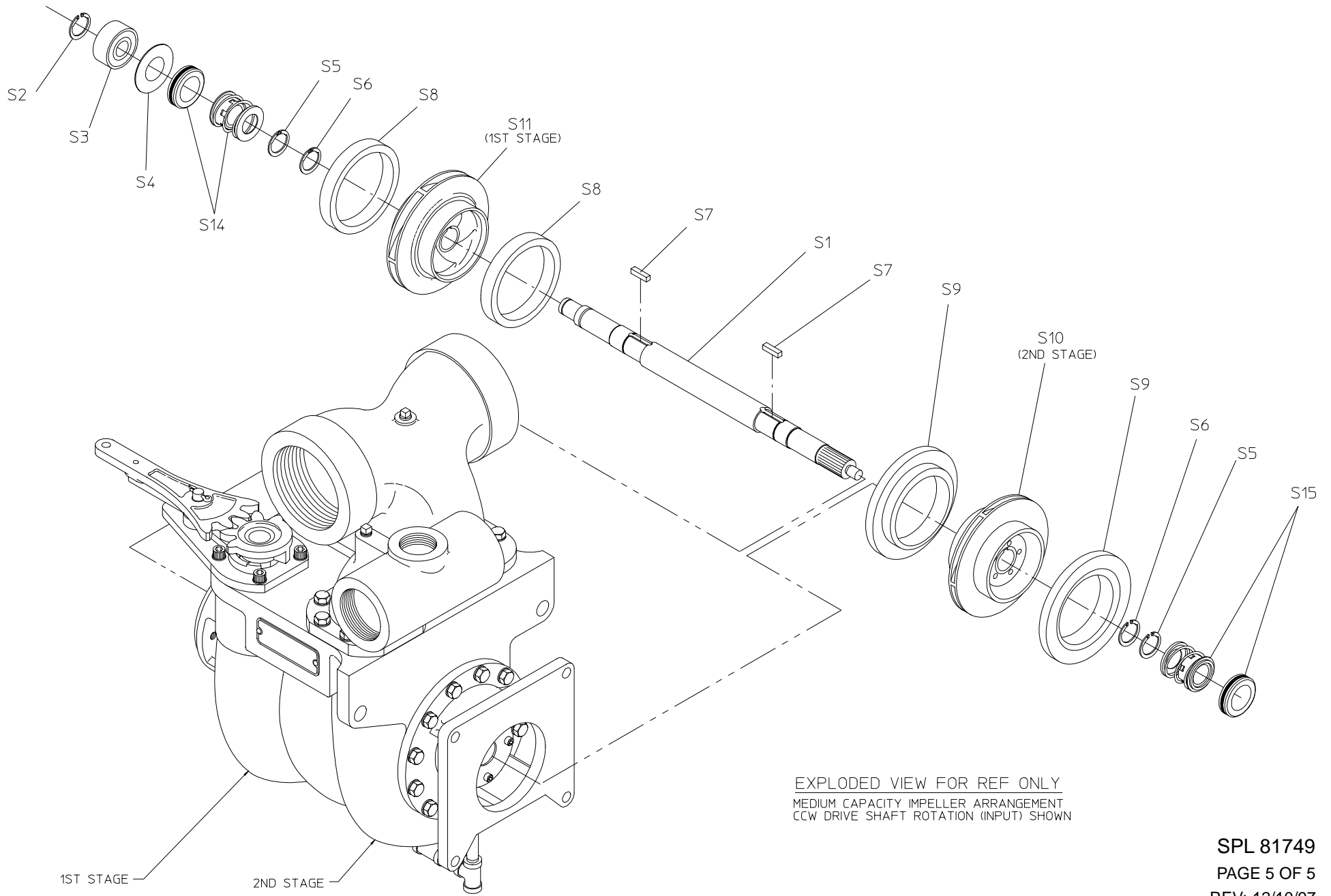

EXPLODED VIEW FOR REF ONLY
 MEDIUM CAPACITY IMPELLER ARRANGEMENT
 CCW DRIVE SHAFT ROTATION (INPUT) SHOWN

