



Document Number	Issue Date	Rev. Date
SPL81963	12/01/93	03/06/13

CM Body Assembly Service Parts List

CM '93 and CM '04 Body Styles

Body Style Identification

Pump Material	Body Style	
	Pumps Built After 2004	Pumps Built Prior to 2004
Iron	CM '04	CM '93
Bronze	CM '93	CM '93

Pump Model	Component				See Page		
					Pumps Built After October 1, 2000	Pumps Built Prior to October 1, 2000	
CM, CMH, CMU, CMUH	Pump Body Halves	View of Body (Top Side)			2, 3	2, 3	
		View of Cover (Underside)			4, 5	6, 7	
		Seal Cooling Line			8, 9	10, 11	
	Intake Adapters	Left Side	CM '93	CM, CMH	Standard	12, 13	12, 13
				CMU, CMUH	Large		
			CM '04	CM, CMH, CMU, CMUH	Large Rear		
				CM, CMH, CMU, CMUH	Large		
		Right Side	CM '93	CM, CMH	Standard	16, 17	16, 17
					Standard Rear		
			CM '04	CMU, CMUH	Large		
					Large Rear		
	CM '04	CM, CMH, CMU, CMUH	Large	18, 19	18, 19		
			Large Rear				
	Tank to Pump Connection				20, 21	20, 21	
Transfer Valve				22, 23	24, 25		

Waterous Company 125 Hardman Avenue South, South St. Paul, Minnesota 55075 USA (651) 450-5000

NOTE: When ordering parts, provide Pump, Transmission or PTO Serial Number.

View of Body (Top Side)

REF. NO.	DESCRIPTION
B10	Serial Plate, Pump Mounted
B15	Gasket Set, Cover-to-Body
B22	Hex Hd Screw, 1/2-13 x 1-1/4 in.
B30	Dowel Pin, 7/16 in. x 1-1/4 in.
B34	Square Hd Pipe Plug, 1/4 in.
B35	Square Hd Pipe Plug, 3/8 in.
B39	Round Hd Drive Screw, No. 6, 1/4 in.
B80	Body Assembly (Sold as assembly only - Consists of Volute Body and Volute Cover)
B89	O-ring, 2-1/2 in. x 2-3/4 in.
B96	Gasket Kit (Consists of B12, B15, B26, B27, B60, B81, B85, B86, B89, B90 & B95)
B109	Serial Plate (Located on Operator's Panel)

REF. NO.	DESCRIPTION
B121	Self-threading Nut
B122	Square Hd Pipe Plug, 1/2 in.
B127	Pipe Plug, 1/2 in. NPT Headless
B128	Front Discharge Plug
B129	O-ring, 3-3/4 x 4 in.
B133	O-ring, 2-1/8 x 2-3/8 in.
B134	Hex Hd Screw, 5/16-18 x 1 in.
B135	Lock Washer, 5/16 in.
B136	Priming Valve Pad Cover
B139	Pipe Plug, 3/4 in. NPT
B140	Priming Valve Pad Cover
B141	O-ring, 1-3/4 x 2 in.

THESE PARTS ARE USED TO COVER CENTER DISCHARGE OPENING WHEN NO PIPING IS REQUIRED.

USED AFTER APRIL 1, 2001.
THESE PARTS ARE USED TO COVER FRONT DISCHARGE OPENING ON IRON PUMPS ONLY WHEN NO PIPING IS REQUIRED.
BRONZE PUMP BODIES DO NOT HAVE A FRONT DISCHARGE FLANGE.

NOTE: DRAIN COCK IS USED IN PLACE OF PIPE PLUG WHEN BODY IS INVERTED.

IRON PUMPS:
AFTER MARCH 20, 2006, FURNISHED WHEN A VACUUM ACTIVATED (VAP) PRIMING VALVE IS NOT ORDERED OR WHEN A MANUAL/ELECTRIC, 12 VOLT SOLENOID OR 24 VOLT SOLENOID PRIMING VALVE IS USED.
PRIOR TO MARCH 20, 2006, NOT USED, PUMP BODY HAD A 3/8 NPT TAP FOR PRIMING VALVE MOUNTING.
BRONZE PUMPS:
ALL YEARS, NOT USED, PUMP BODY HAS A 3/8 NPT TAP FOR PRIMING VALVE MOUNTING.

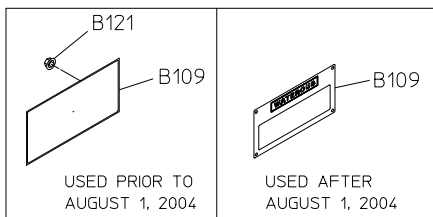
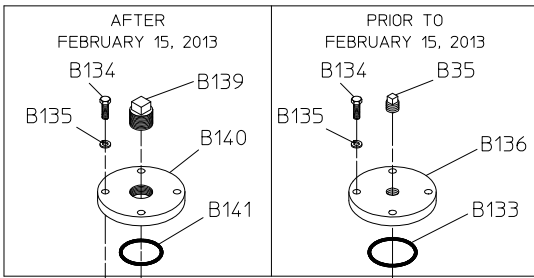

SERIAL PLATE MOUNTED ON PUMP OPERATORS PANEL

B122
USED AFTER FEBRUARY 1, 2000

B127
USED AFTER FEBRUARY 1, 2000

USED AFTER SEPTEMBER 2006

B22
USED AFTER MAY 11, 2001

B129
USED AFTER MAY 11, 2001

B128
USED AFTER MAY 11, 2001

B22
(TORQUE TO 85 LB-FT MIN)

B34 (IRON PUMPS)
B35 (BRONZE PUMPS)

PUMP BODY WITH FRONT DISCHARGE REMOVED
(MAINLY USED ON CMH/CMUH PUMP BODIES)

B96

GASKET KIT

★ PART OF GASKET KIT B96

PUMP BODY

View of Cover (Underside)

Pumps Built After October 1, 2000

REF. NO.	DESCRIPTION
B17	Socket Hd Screw, 5/8-11 x 3-1/4 in.
B19	Hex Hd Screw, 1/2-13 x 4-3/4 in.
B20	Hex Hd Screw, 1/2-13 x 3-1/2 in.
B21	Hex Hd Screw, 1/2-13 x 1 in.
B29	Plain Copper Washer, 1/2 in.
B30	Dowel Pin, 7/16 in. x 1-1/4 in.
B32	Pipe Nipple, 1/4 in. x 1-1/2 in.
B33	Pipe Tee, 1/4 in.
B34	Square Hd Pipe Plug, 1/4 in.

REF. NO.	DESCRIPTION
B43	Hex Hd Screw, 1/2-13 x 1-1/2 in.
B84	Socket Hd Screw, 5/16-18 x 3/4 in.
B91	Socket Hd Screw, 1/2-13 x 4-3/4 in.
B110	Socket Hd Screw, 1/2-13 x 1-1/2 in.
B122	Square Hd Pipe Plug, 1/2 in.
B130	Socket Hd Screw, 1/2-13 x 1-1/2 in.
B131	Socket Hd Screw, 1/2-13 x 3-1/2 in.

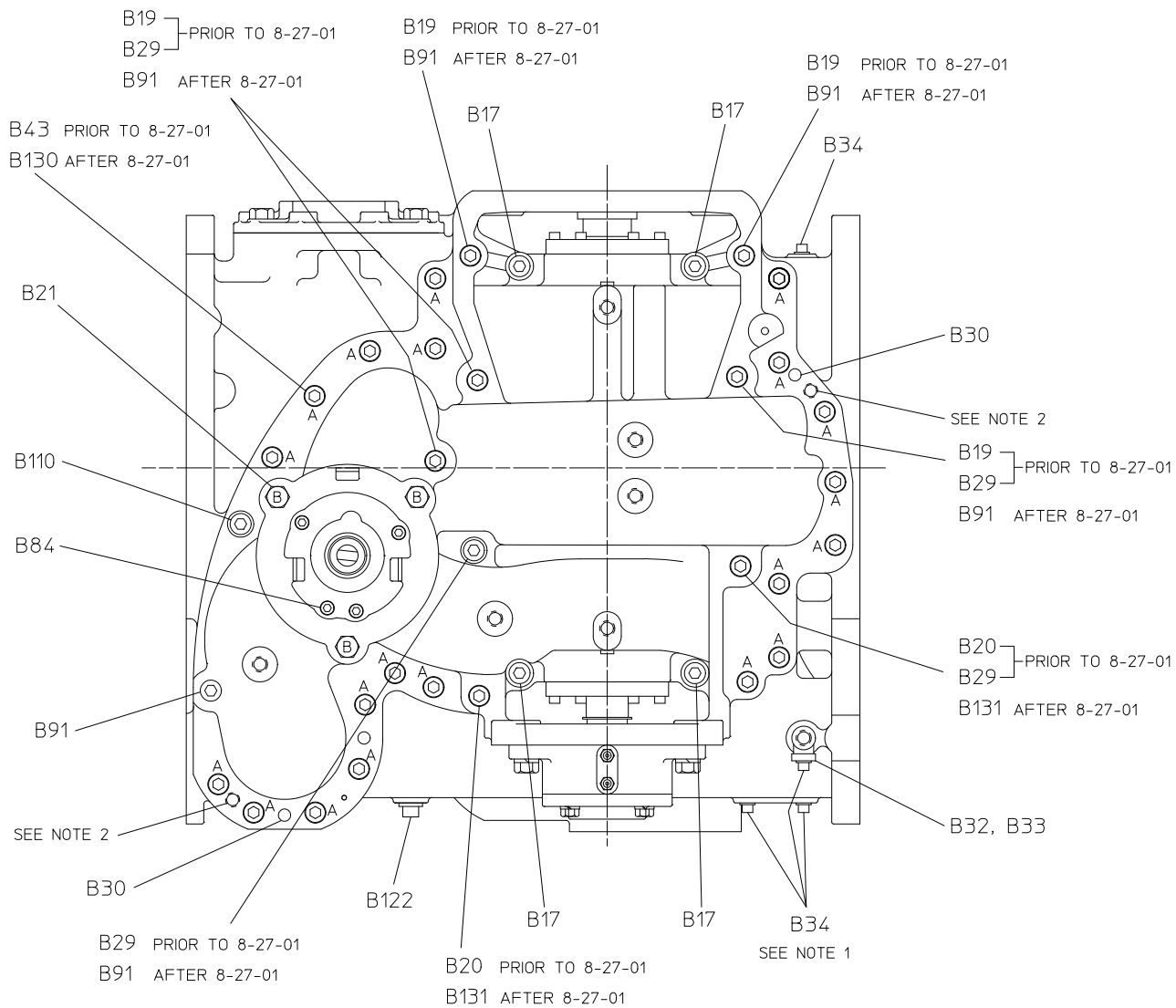

FASTENER TYPE AND SIZE			
REF. NO.	DESCRIPTION	QTY	MINIMUM TORQUE
B17	SOCKET HEAD, 5/8-11 X 3-1/4	4	105 LB-FT
B19	HEX HEAD, 1/2-13 X 4-3/4	5	
B20	HEX HEAD, 1/2-13 X 3-1/2	2	
B21	HEX HEAD, 1/2-13 X 1	3	
B29	COPPER WASHER, 1/2	5	105 LB-FT
B43	HEX HEAD, 1/2-13 X 1-1/2	20	
B84	SOCKET HEAD, 5/16-18 X 3/4	4	
B91	SOCKET HEAD, 1/2-13 X 4-3/4	7	
B110	SOCKET HEAD, 1/2-13 X 1-1/2	1	105 LB-FT
B130	SOCKET HEAD, 1/2-13 X 1-1/2	20	
B131	SOCKET HEAD, 1/2-13 X 3-1/2	2	

UNDERSIDE VIEW OF PUMP

CM/CMU USED WITH ALL MODELS OF ROTARY STYLE TRANSFER VALVE ACTUATOR. (USED AFTER 10-1-00)

NOTES:

1. WATEROUS FURNISHES PUMP WITH B34 PIPE PLUGS INSTALLED IN THESE HOLES, BUT THE APPARATUS BUILDER MAY HAVE REMOVED THEM AND INSTALLED PIPING TO THE DRAIN VALVE.
2. THESE ARE 1/2-13 UNC TAPPED HOLES TO ACCOMMODATE THE USE OF JACKING SCREWS DURING DISASSEMBLY.

View of Cover (Underside)
Pumps Built Prior to October 1, 2000

REF. NO.	DESCRIPTION
B17	Socket Hd Screw, 5/8-11 x 3-1/4 in.
B19	Hex Hd Screw, 1/2-13 x 4-3/4 in.
B20	Hex Hd Screw, 1/2-13 x 3-1/2 in.
B21	Hex Hd Screw, 1/2-13 x 1 in.
B29	Plain Copper Washer, 1/2 in.
B30	Dowel Pin, 7/16 in. x 1-1/4 in.
B32	Pipe Nipple, 1/4 in. x 1-1/2 in.
B33	Pipe Tee, 1/4 in.
B34	Square Hd Pipe Plug, 1/4 in.

REF. NO.	DESCRIPTION
B43	Hex Hd Screw, 1/2-13 x 1-1/2 in.
B84	Socket Hd Screw, 5/16-18 x 3/4 in.
B91	Socket Hd Screw, 1/2-13 x 4-3/4 in.
B110	Socket Hd Screw, 1/2-13 x 1-1/2 in.
B122	Square Hd Pipe Plug, 1/2 in.

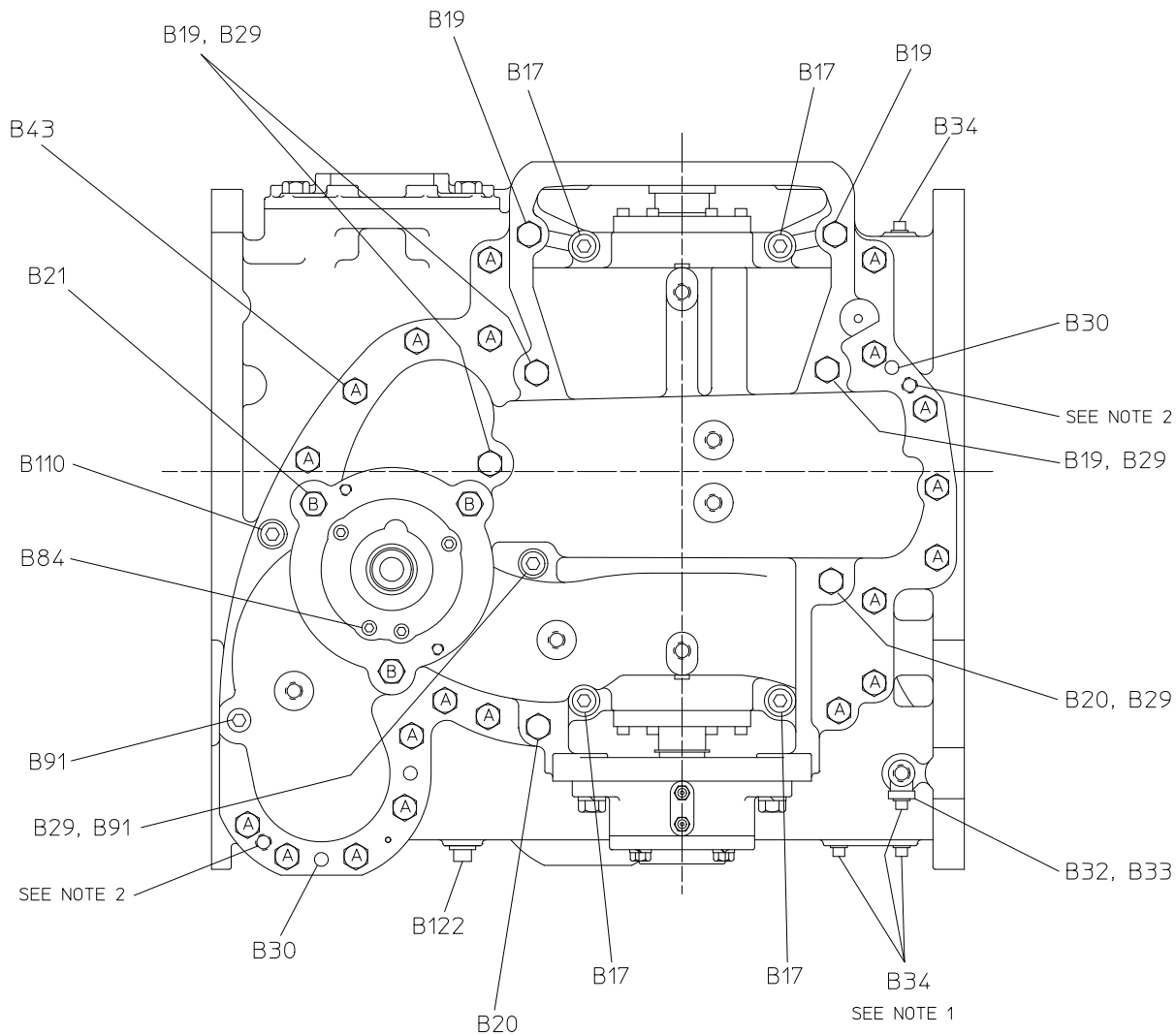

FASTENER TYPE AND SIZE			
REF. NO.	DESCRIPTION	QTY	MINIMUM TORQUE
B17	SOCKET HEAD, 5/8-11 X 3-1/4	4	105 LB-FT
* B19	HEX HEAD, 1/2-13 X 4-3/4	5	
* B20	HEX HEAD, 1/2-13 X 3-1/2	2	
B21	HEX HEAD, 1/2-13 X 1	3	105 LB-FT
B29	COPPER WASHER, 1/2	5	
B43	HEX HEAD, 1/2-13 X 1-1/2	20	105 LB-FT
B84	SOCKET HEAD, 5/16-18 X 3/4	4	105 LB-FT
* B91	SOCKET HEAD, 1/2-13 X 4-3/4	2	
B110	SOCKET HEAD, 1/2-13 X 1-1/2	1	

* MINIMUM TORQUE OF 85 LB-FT WHEN USED WITH COPPER WASHERS

UNDERSIDE VIEW OF PUMP

CM/CMU USED WITH ALL MODELS OF THE OLD STYLE RECIPROCATING TRANSFER VALVE ACTUATOR ASSEMBLY. (USED PRIOR TO 10-1-00)

NOTES:

1. WATEROUS FURNISHES PUMP WITH B34 PIPE PLUGS INSTALLED IN THESE HOLES, BUT THE APPARATUS BUILDER MAY HAVE REMOVED THEM AND INSTALLED PIPING TO THE DRAIN VALVE.
2. THESE ARE 1/2-13 UNC TAPPED HOLES TO ACCOMMODATE THE USE OF JACKING SCREWS DURING DISASSEMBLY.

**Seal Cooling Line
Pumps Built After October 1, 2000**

REF. NO.	DESCRIPTION
B77	Hose Assembly, 1/4 in.
B78	Male Elbow, 90°, 1/8 NPT x 1/4 Tube

REF. NO.	DESCRIPTION
B79	Connector, 1/8 in. x 1/4 Tube
B93	Square Hd Pipe Plug, 1/8 in.
B138	Compression Tee Fitting

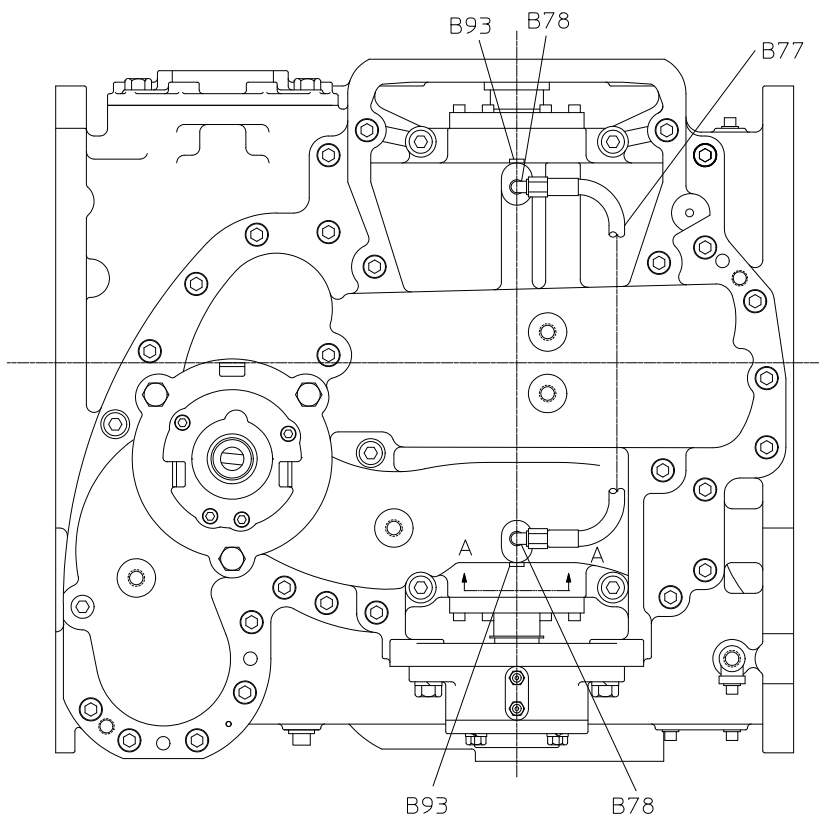

PRIOR TO AUGUST 16, 2010

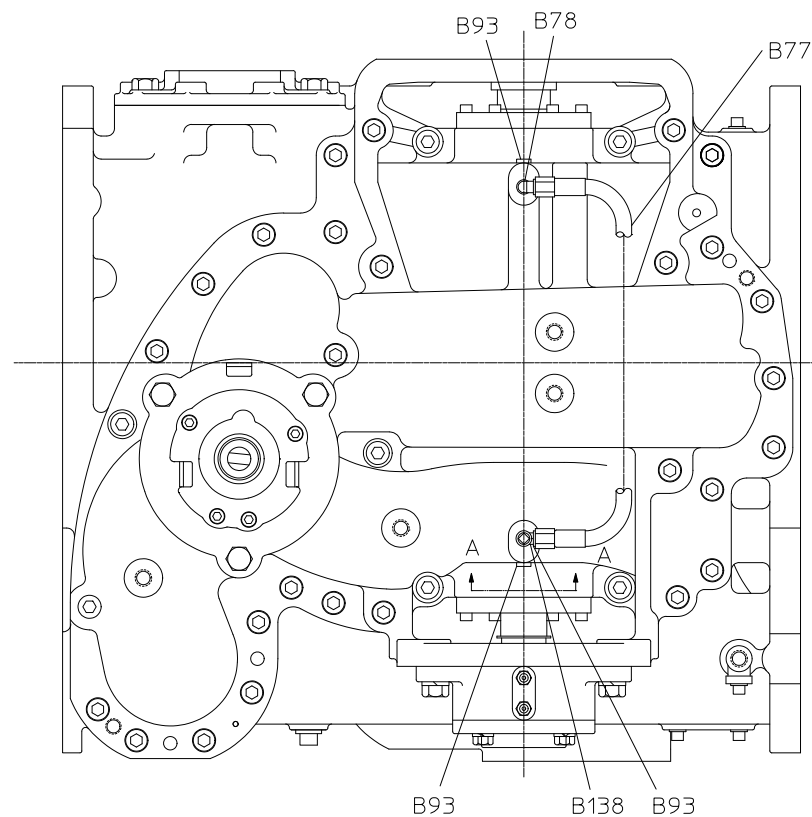

AFTER AUGUST 16, 2010

NOTE:
 TEE AND NIPPLE REPLACE
 ELBOW B78 PRIOR TO AUGUST 16, 2010
 B93 AND B138 AFTER AUGUST 16, 2010
 WHEN EXTRA PRESSURE STAGE
 IS ADDED. (THE TEE AND NIPPLE
 ARE PART OF EXTRA
 PRESSURE STAGE ASSEMBLY).

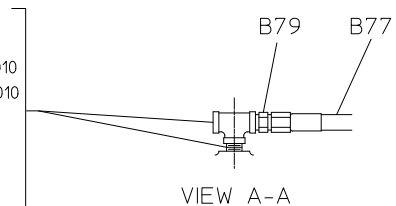

(PIPING FOR EXTRA PRESSURE STAGE ASSEMBLY CMH/CMUH)

SEAL COOLING LINE

CM/CMU USED WITH ALL MODELS OF ROTARY STYLE
 TRANSFER VALVE ACTUATOR. (USED AFTER OCTOBER 1, 2000)

**Seal Cooling Line
Pumps Built Prior to October 1, 2000**

REF. NO.	DESCRIPTION
B77	Hose Assembly, 1/4 in.
B78	Male Elbow, 90°, 1/8 NPT x 1/4 Tube
B79	Connector, 1/8 in. x 1/4 Tube

REF. NO.	DESCRIPTION
B93	Square Hd Pipe Plug, 1/8 in.
B107	Pipe Coupling, 1/8 in.
B108	Pipe Nipple, 1/8 in. x 3/4 in.
B124	Pipe Nipple, 1/8 in. x 1-1/2 in.

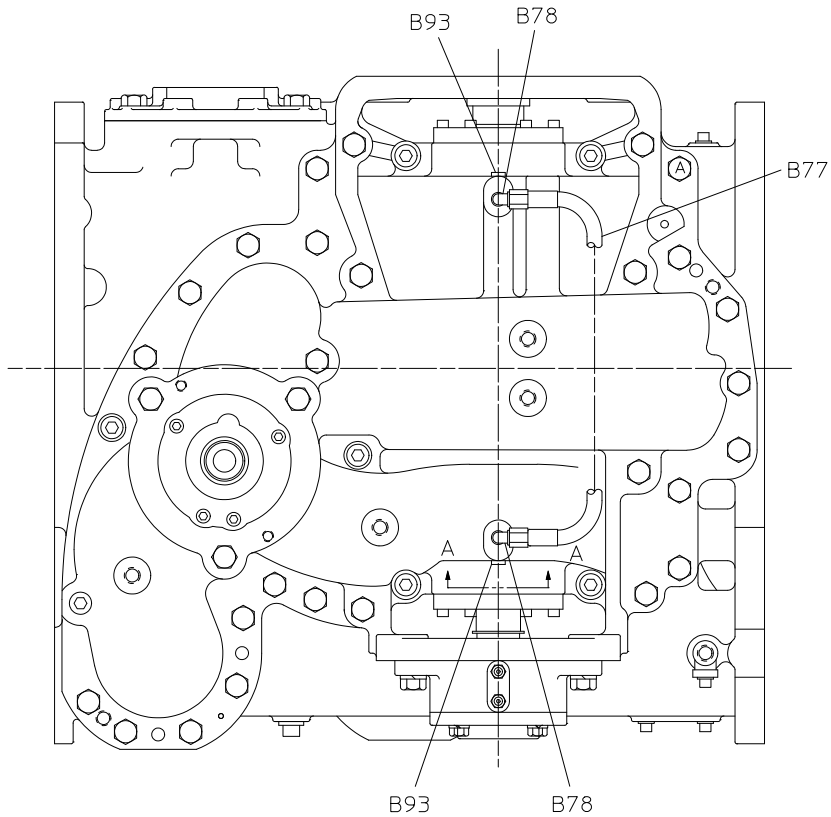

NOTE: TEE AND NIPPLE REPLACE ELBOW B78 WHEN EXTRA PRESSURE STAGE IS ADDED. (THE TEE AND NIPPLE ARE PART OF EXTRA PRESSURE STAGE ASSEMBLY).

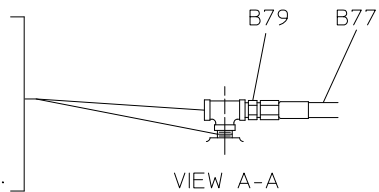

VIEW A-A

(PIPING FOR EXTRA PRESSURE STAGE ASSEMBLY CMH/CMUH)

SEAL COOLING LINE

CM/CMU USED WITH ALL MODELS OF THE OLD STYLE RECIPROCATING TRANSFER VALVE ACTUATOR EXCEPT THE BOTTOM MOUNTED ELECTRIC TRANSFER VALVE ACTUATOR ASSEMBLY. (USED PRIOR TO 10-1-00)

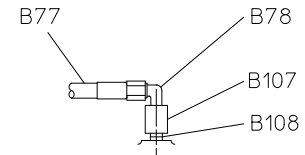
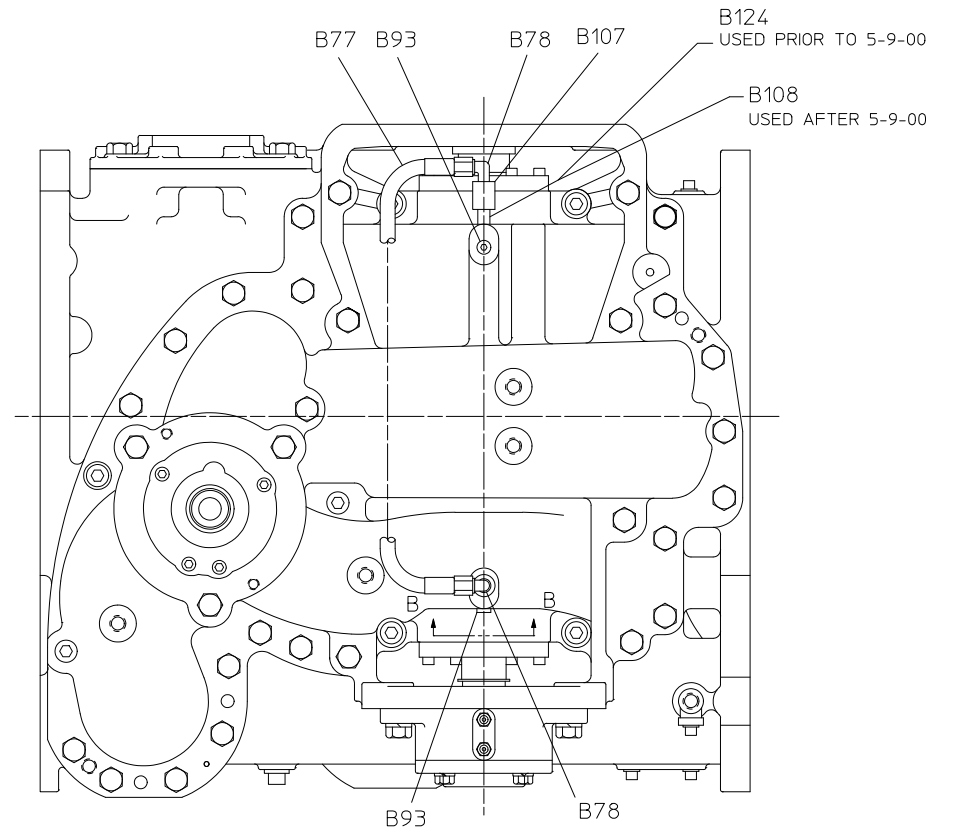

VIEW B-B

SEAL COOLING LINE

CM/CMU USED WITH OLD STYLE BOTTOM MOUNTED ELECTRIC RECIPROCATING TRANSFER VALVE ACTUATOR. (USED PRIOR TO 10-1-00)

Intake Adapters - Left Side CM '93 Pumps

REF. NO.	DESCRIPTION
B1	Flap Valve, Small Intake Adapter
B5	Intake Fitting Gasket, Small Adapter
B6	Intake Adapter, LH
B12	Intake Flange Gasket
B22	Hex Hd Screw, 1/2-13 x 1-1/4 in.
B23	Hex Hd Screw, 3/4-10 x 2 in.
B35	Square Hd Pipe Plug, 3/8 in.
B62	Flap Valve, Rear Intake
B63	Rear Intake Fitting Gasket
B74	Rear Intake Fitting
B75	Hex Hd Screw, 1/2-20 x 2 in.

REF. NO.	DESCRIPTION
B76	Hex Nut, 1/2-20
B90	Intake Flange Gasket (Bronze Body Only)
B95	Discharge Flange Gasket
B96	Gasket kit (Consists of B12, B15, B26, B27, B60, B81, B85, B86, B89, B90 & B95)
B97	Flap Valve, Large Intake Adapter
B98	Intake Fitting Gasket, Large Intake Adapter
B123	Plain Bearing, TFE (Intake Adapter Flap Valve)
B125	Plain Bearing, TFE (Rear Intake Flap Valve)
B126	Hex Hd Screw, 5/8-11 x 2 in.
B137	Hex Hd Screw, 3/4-10 x 1-3/4 in. with Threadlocker

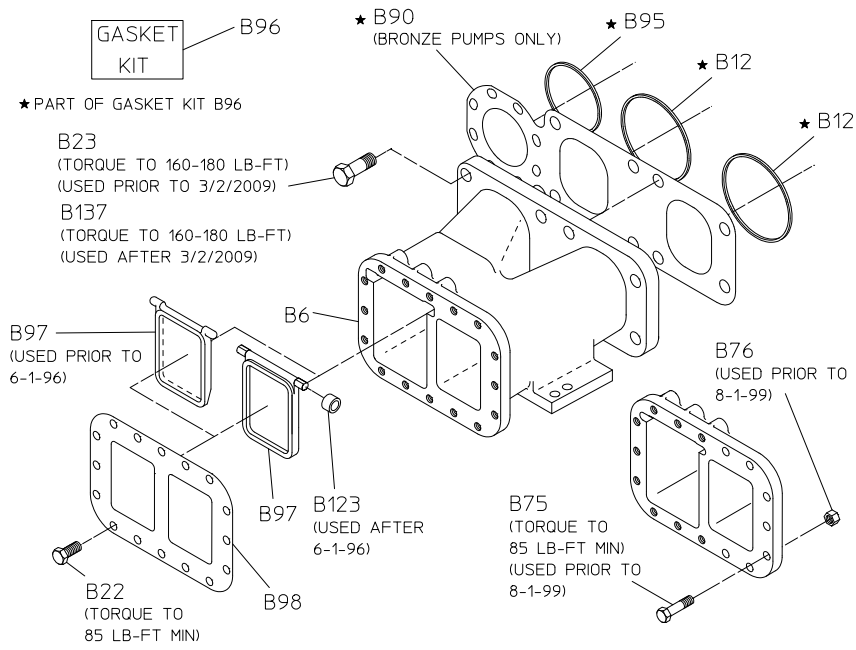

CM'93 LEFT SIDE LARGE INTAKE ADAPTER

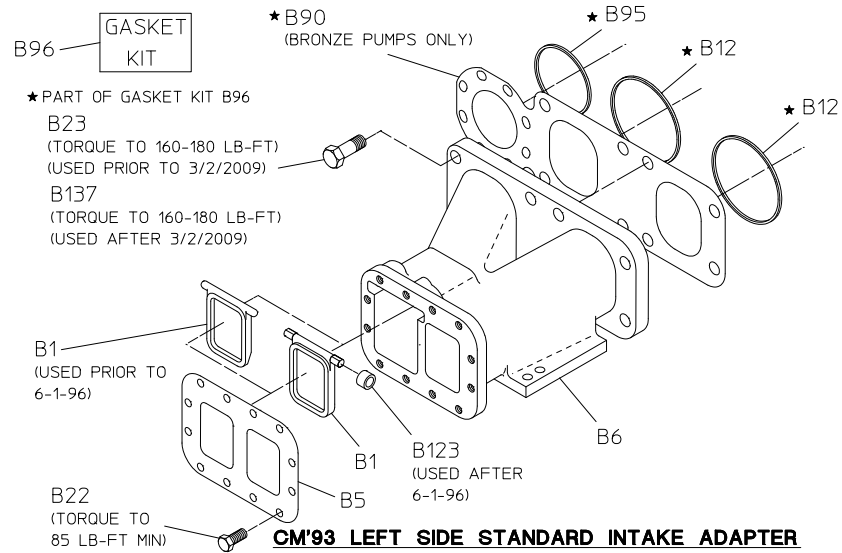

CM'93 LEFT SIDE STANDARD INTAKE ADAPTER

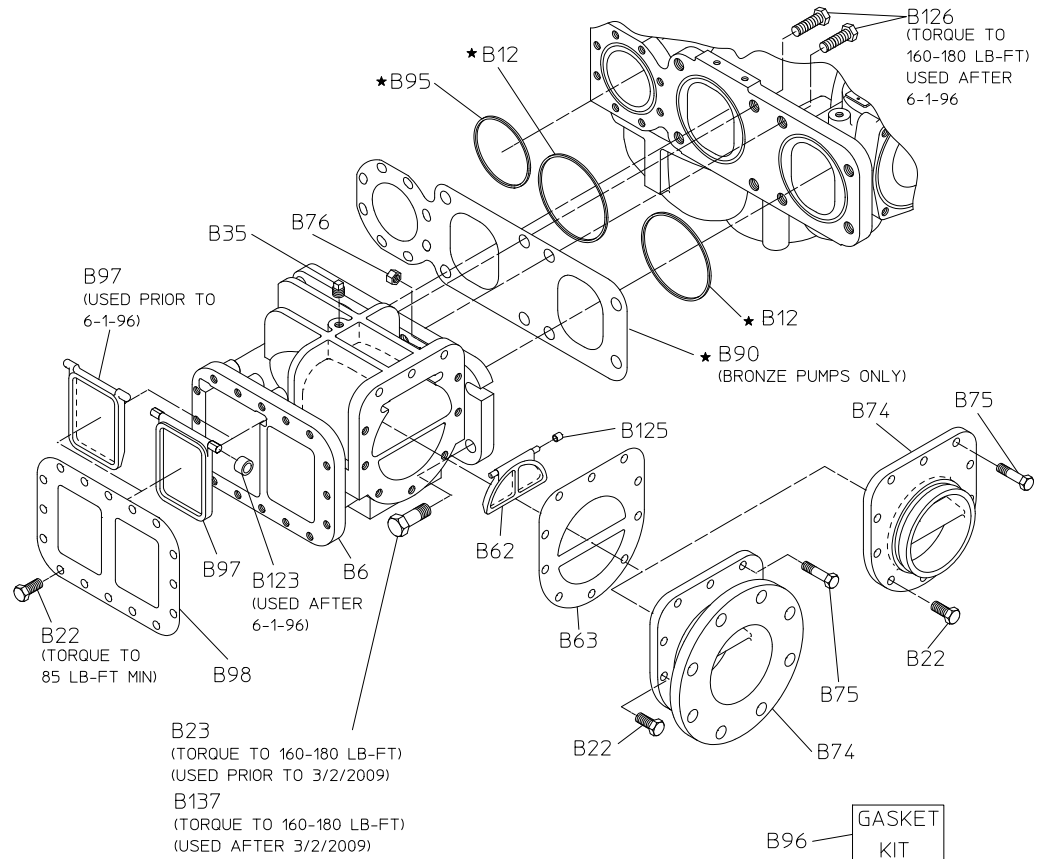

CM'93 LEFT SIDE LARGE REAR INTAKE ADAPTER

Intake Adapters - Left Side CM '04 Pumps

REF. NO.	DESCRIPTION
B6	Intake Adapter, LH
B12	Intake Flange Gasket
B22	Hex Hd Screw, 1/2-13 x 1-1/4 in.
B23	Hex Hd Screw, 3/4-10 x 2 in.
B35	Square Hd Pipe Plug, 3/8 in.
B62	Flap Valve, Rear Intake
B63	Rear Intake Fitting Gasket
B74	Rear Intake Fitting
B75	Hex Hd Screw, 1/2-20 x 2 in.

REF. NO.	DESCRIPTION
B76	Hex Nut, 1/2-20
B95	Discharge Flange Gasket
B96	Gasket kit (Consists of B12, B15, B26, B27, B60, B81, B85, B86, B89, B90 & B95)
B97	Flap Valve, Large Intake Adapter
B98	Intake Fitting Gasket, Large Intake Adapter
B123	Plain Bearing, TFE (Intake Adapter Flap valve)
B125	Plain Bearing, TFE (Rear Intake Flap valve)
B126	Hex Hd Screw, 5/8-11 x 2 in.
B137	Hex Hd Screw, 3/4-10 x 1-3/4 in. with Threadlocker

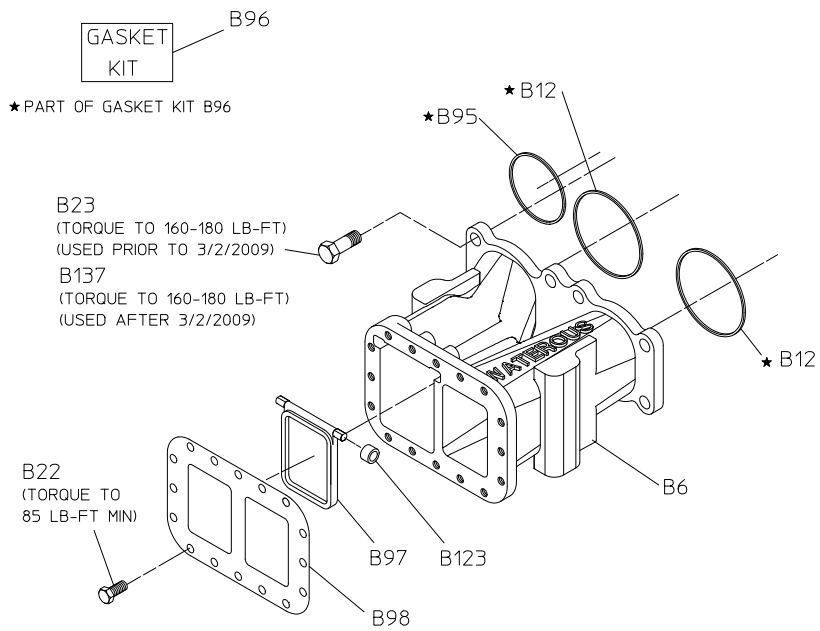

CM'04 LEFT SIDE UNIVERSAL INTAKE ADAPTER

IRON PUMPS ONLY

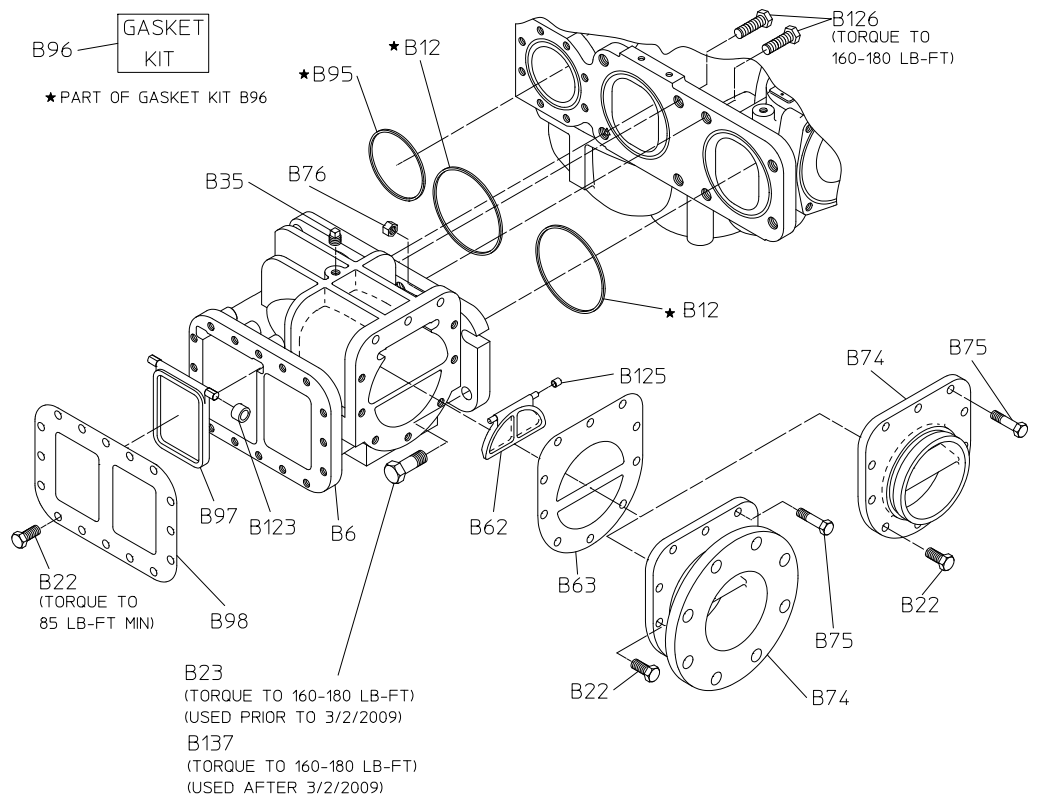

CM'04 LEFT SIDE LARGE REAR INTAKE ADAPTER

IRON PUMPS ONLY

Intake Adapters - Right Side

CM '93 Pumps

REF. NO.	DESCRIPTION
B1	Flap Valve, Small Intake Adapter
B5	Intake Fitting Gasket, Small Adapter
B7	Intake Adapter, RH (or Rear Intake Adapter, RH)
B12	Intake Flange Gasket
B22	Hex Hd Screw, 1/2-13 x 1-1/4 in.
B23	Hex Hd Screw, 3/4-10 x 2 in.
B35	Square Hd Pipe Plug, 3/8 in.
B62	Flap Valve, Rear Intake
B63	Rear Intake Fitting Gasket
B74	Rear Intake Fitting
B75	Hex Hd Screw, 1/2-20 x 2 in.

REF. NO.	DESCRIPTION
B76	Hex Nut, 1/2-20
B90	Intake Flange Gasket (Bronze Body Only)
B95	Discharge Flange Gasket
B96	Gasket kit (Consists of B12, B15, B26, B27, B60, B81, B85, B86, B89, B90 & B95)
B97	Flap Valve, Large Intake Adapter
B98	Intake Fitting Gasket, Large Intake Adapter
B123	Plain Bearing, TFE (Intake Adapter Flap Valve)
B125	Plain Bearing, TFE (Rear Intake Flap Valve)
B126	Hex Hd Screw, 5/8-11 x 2 in.
B137	Hex Hd Screw, 3/4-10 x 1-3/4 in. with Threadlocker

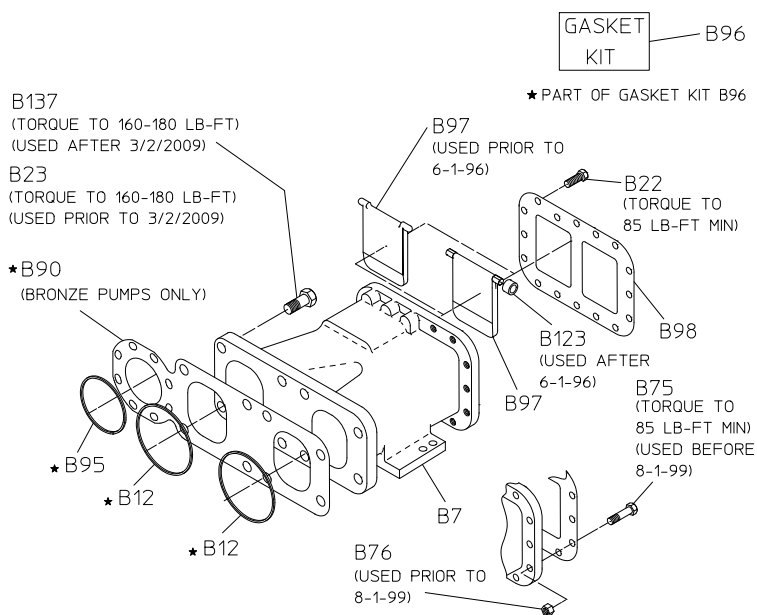

CM'93 RIGHT SIDE LARGE INTAKE ADAPTER

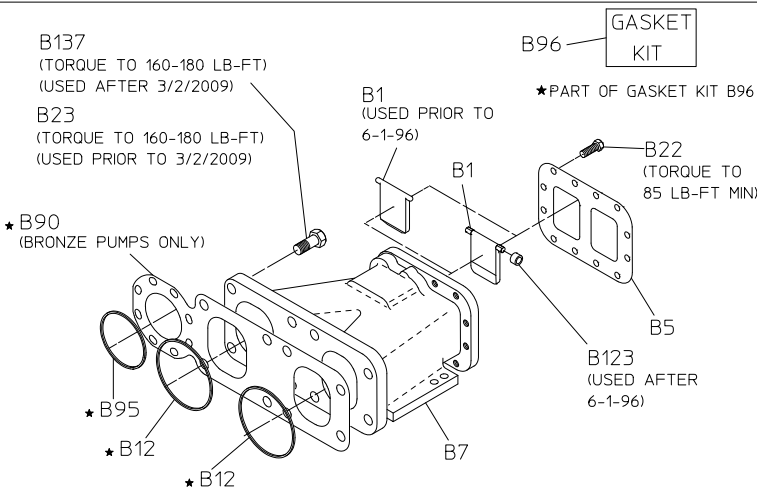

CM'93 RIGHT SIDE STANDARD INTAKE ADAPTER

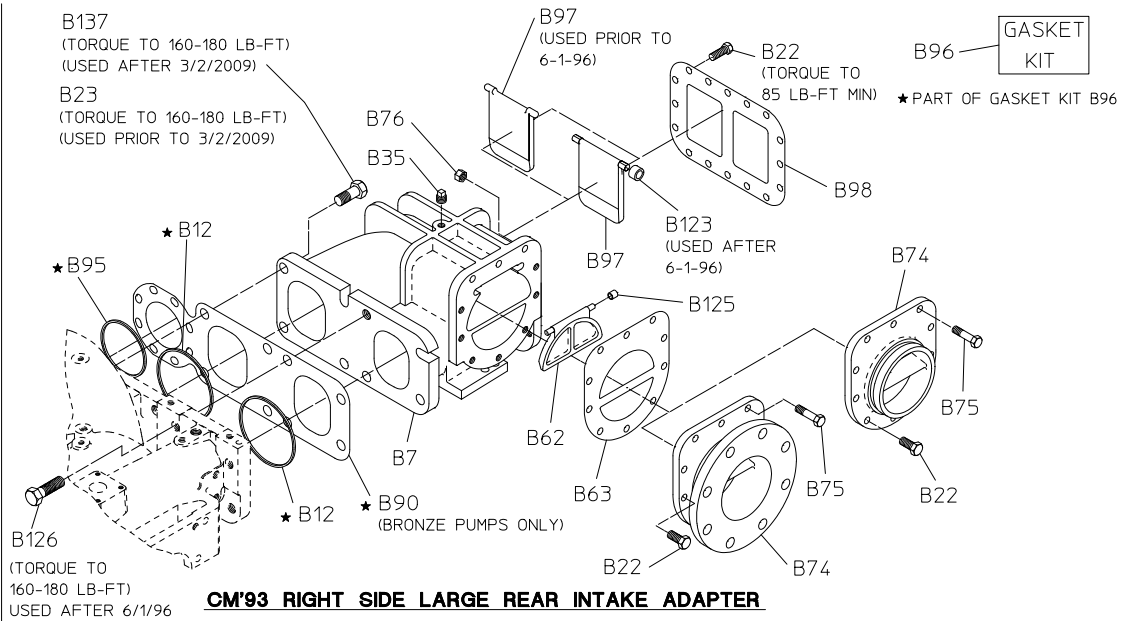

CM'93 RIGHT SIDE LARGE REAR INTAKE ADAPTER

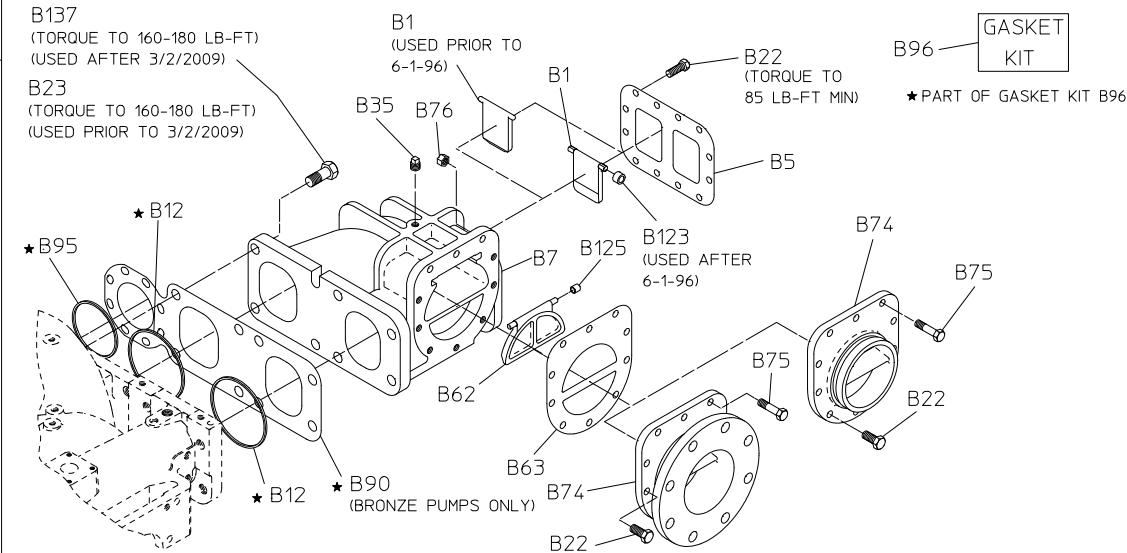

CM'93 RIGHT SIDE STANDARD REAR INTAKE ADAPTER

Intake Adapters - Right Side

CM '04 Pumps

REF. NO.	DESCRIPTION
B7	Intake Adapter, RH (or Rear Intake Adapter, RH)
B12	Intake Flange Gasket
B22	Hex Hd Screw, 1/2-13 x 1-1/4 in.
B23	Hex Hd Screw, 3/4-10 x 2 in.
B35	Square Hd Pipe Plug, 3/8 in.
B62	Flap Valve, Rear Intake
B63	Rear Intake Fitting Gasket
B74	Rear Intake Fitting
B75	Hex Hd Screw, 1/2-20 x 2 in.

REF. NO.	DESCRIPTION
B76	Hex Nut, 1/2-20
B95	Discharge Flange Gasket
B96	Gasket kit (Consists of B12, B15, B26, B27, B60, B81, B85, B86, B89, B90 & B95)
B97	Flap Valve, Large Intake Adapter
B98	Intake Fitting Gasket, Large Intake Adapter
B123	Plain Bearing, TFE (Intake Adapter Flap Valve)
B125	Plain Bearing, TFE (Rear Intake Flap Valve)
B126	Hex Hd Screw, 5/8-11 x 2 in.
B137	Hex Hd Screw, 3/4-10 x 1-3/4 in. with Threadlocker

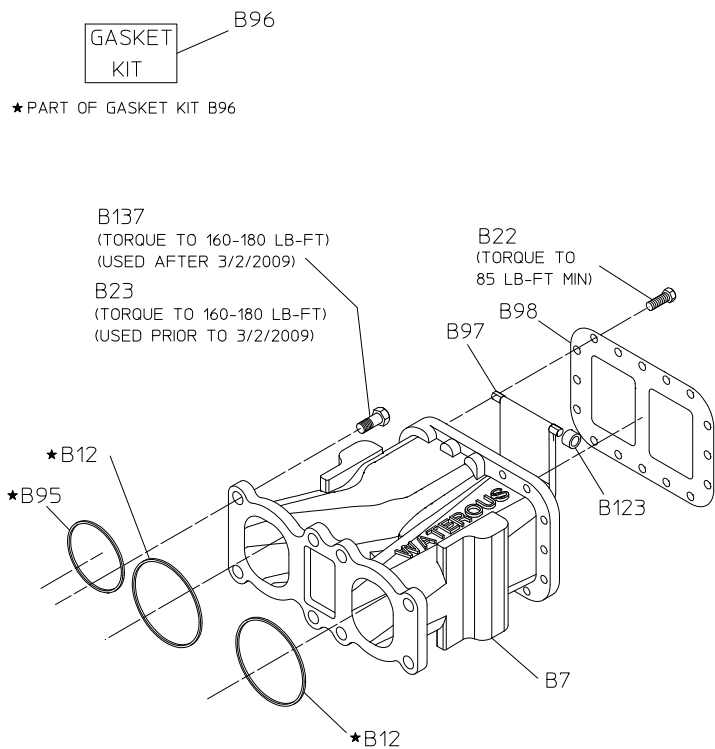

CM'04 RIGHT SIDE UNIVERSAL INTAKE ADAPTER

IRON PUMPS ONLY

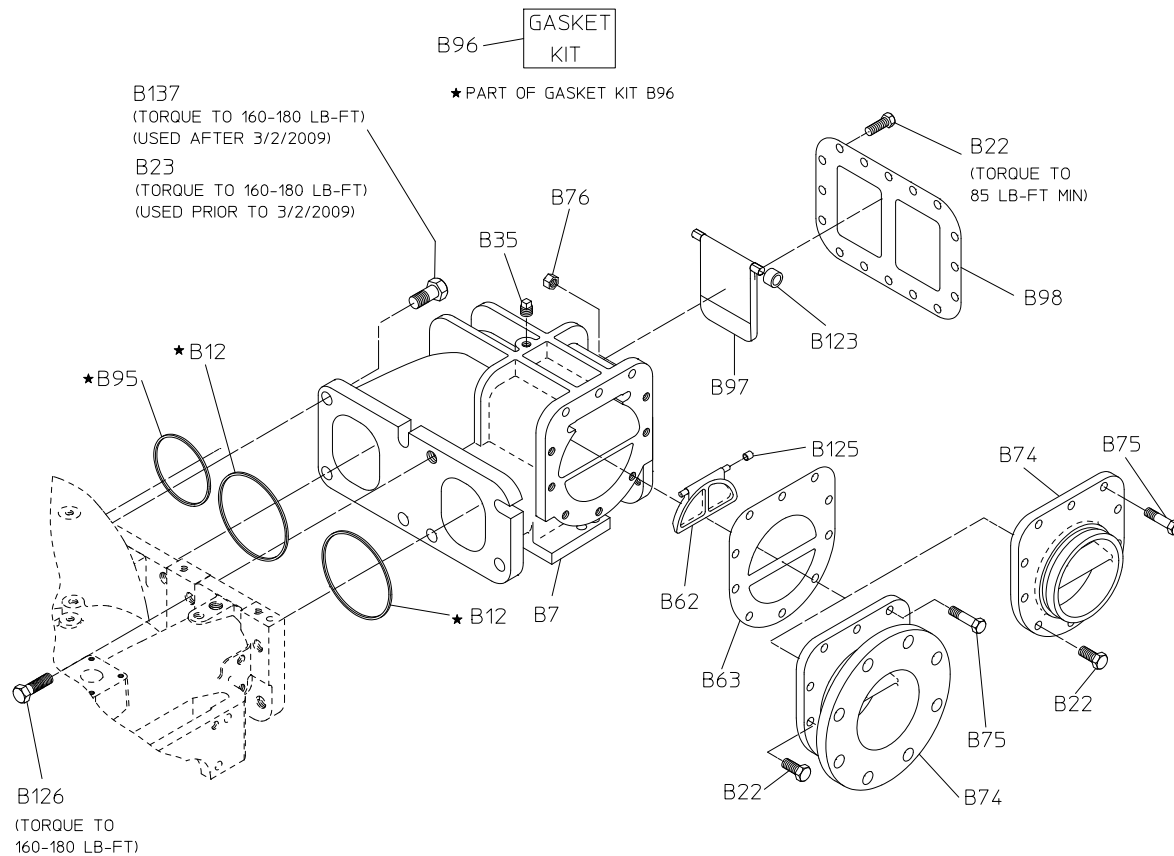

CM'04 RIGHT SIDE LARGE REAR INTAKE ADAPTER

IRON PUMPS ONLY

Tank to Pump Connection

REF. NO.	DESCRIPTION
B22	Hex Hd Screw, 1/2-13 x 1-1/4 in.
B60	O-ring, 6-3/4 in. x 7 in.
B61	Blind Flange
B64	Tank Intake Adapter (2-1/2 in. NPT, 3 in. NPT or 4 in. ANSI Flange)

REF. NO.	DESCRIPTION
B72	Tank to Pump Check Valve
B80	Body Assembly (Sold as Assembly Only - Consists of Volute Body and Volute Cover)
B96	Gasket Kit (Consists of B12, B15, B26, B27, B60, B81, B85, B86, B89, B90 & B95)
B123	Plain Bearing, TFE (Intake Adapter Flap Valve)
B132	Plain Bearing, TFE (Tank to Pump Check Valve)

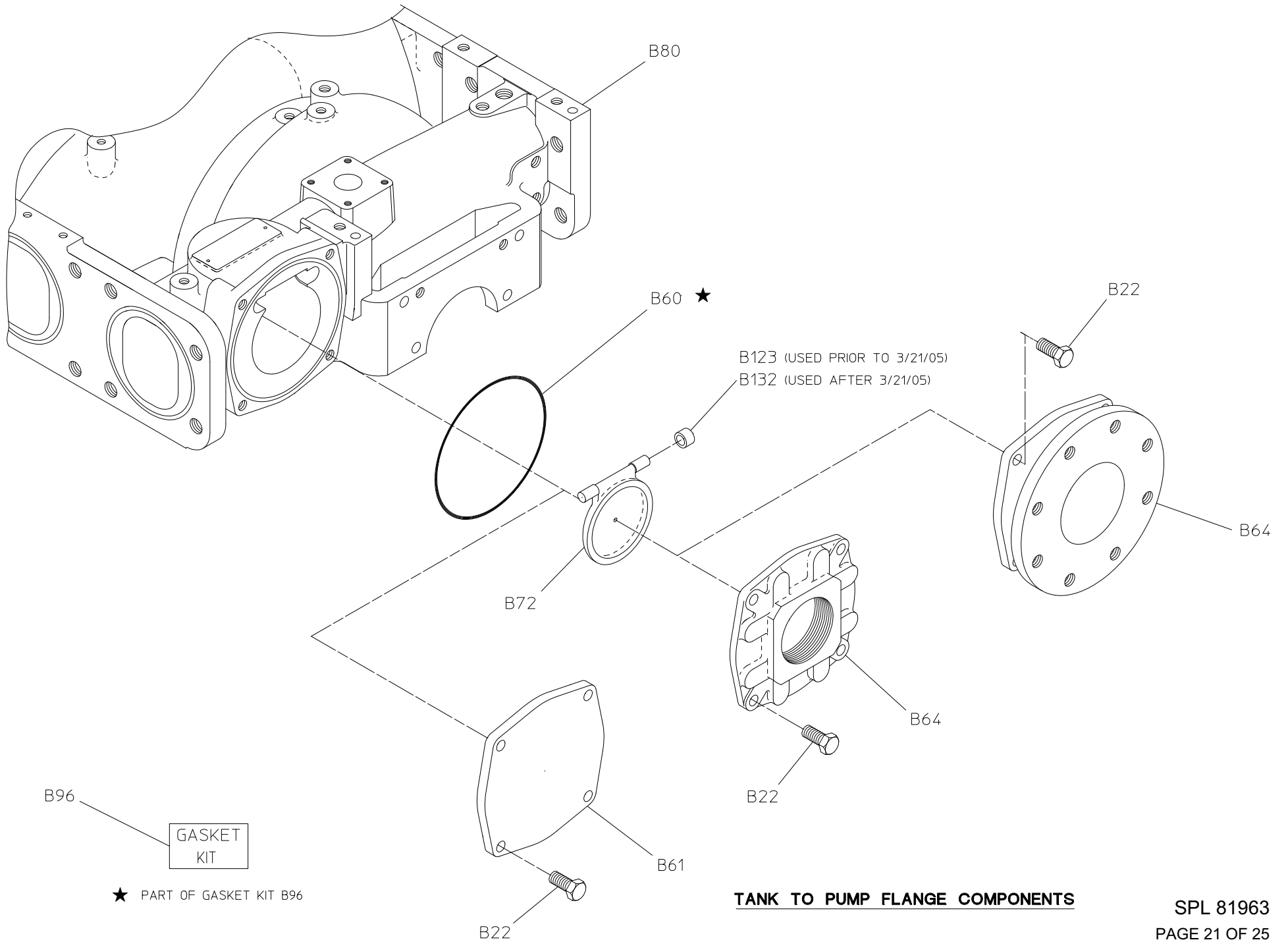

Transfer Valve Pumps Built After October 1, 2000

REF. NO.	DESCRIPTION
B11	Transfer Valve Stem Bushing
B16	Transfer Valve Housing Assembly
B14	Transfer Valve Ball
B21	Hex Hd Screw, 1/2-13 x 1 in
B26	O-ring, 1-1/8 in. x 1-3/8 in.
B27	O-ring, 5 in. x 5-1/4 in.
B31	Groove Pin
B80	Body Assembly (Sold as Assembly only - Consists of Volute Body and Volute Cover)

REF. NO.	DESCRIPTION
B81	Transfer Valve Housing Gasket
B82	Transfer Valve Seal
B83	Transfer Valve Cover
B84	Socket Hd Screw, 5/16-18 x 3/4 in.
B85	O-ring, 1-5/8 in. x 1-7/8 in.
B86	O-ring, 3-1/8 in. x 3-1/2 in.
B88	Transfer Valve Seal Spring
B96	Gasket kit (Consists of B12, B15, B26, B27, B60, B81, B85, B86, B89, B90 & B95)
B116	Transfer Valve Repair Kit (Consists of B11, B26, B27, B31, B81, B82, B85, B86 and B88)

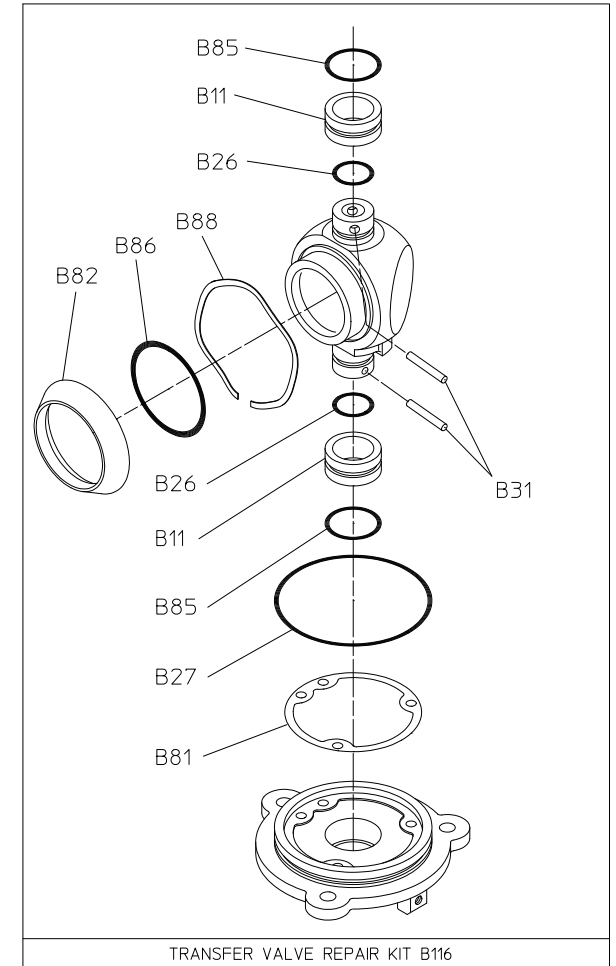
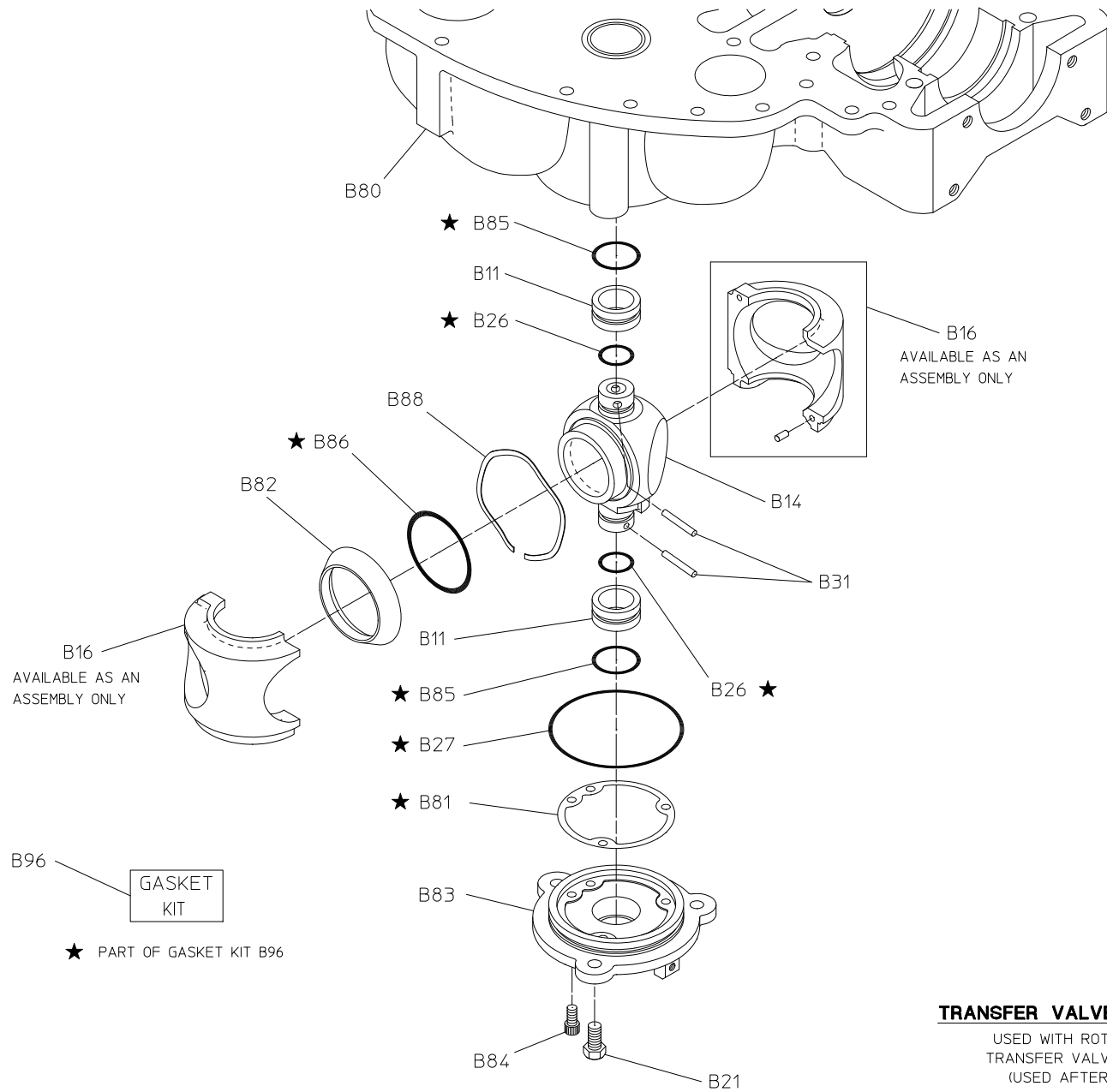

TRANSFER VALVE COMPONENTS

USED WITH ROTARY STYLE
TRANSFER VALVE ACTUATOR
(USED AFTER 10-1-00)

Transfer Valve Pumps Built Prior to October 1, 2000

REF. NO.	DESCRIPTION
B11	Transfer Valve Stem Bushing
B14	Transfer Valve Ball
B16	Transfer Valve Housing Assembly
B21	Hex Hd Screw, 1/2-13 x 1 in
B26	O-ring, 1-1/8 in. x 1-3/8 in.
B27	O-ring, 5 in. x 5-1/4 in.
B31	Groove Pin
B80	Body Assembly (Sold as Assembly Only - Consists of Volute Body and Volute Cover)

REF. NO.	DESCRIPTION
B81	Transfer Valve Housing Gasket
B82	Transfer Valve Seal
B83	Transfer Valve Cover
B84	Socket Hd Screw, 5/16-18 x 3/4 in.
B85	O-ring, 1-5/8 in. x 1-7/8 in.
B86	O-ring, 3-1/8 in. x 3-1/2 in.
B87	Dowel Pin, SS, 1/4 in. x 3/4 in.
B88	Transfer Valve Seal Spring
B96	Gasket kit (Consists of B12, B15, B26, B27, B60, B81, B85, B86, B89, B90 & B95)
B116	Transfer Valve Repair Kit (Consists of B11, B26, B27, B31, B81, B82, B86, B87 and B88)

