



Document Number	Issue Date	Rev. Date
SPL81995	02/11/94	02/02/12

Standard Model Floto Pump Service Parts List

Index:

Components		See Page
Float and Fuel System		2, 3
Exhaust and Air Intake	Prior to July 21, 2006	4, 5
Exhaust and Air Intake	After July 21, 2006	6, 7
Pump		8, 9
Engine, Starter and Ignition		10, 11
Engine, Caruretor and Power Head		12, 13

Float and Fuel System

REF. NO.	DESCRIPTION
8	Float
13	Self-locking nut, 3/8-16
14	Plain washer, 3/8 in.
15	Intake screen
26	Fuel line
31	Fuel tank cap
38	Hex hd screw, 3/8-16 x 2-3/4 in.
41	Fuel line filter
42	Internal tooth lock washer, 1/4 in.
49	RUN-STOP decal
50	Fuel mix decal
51	Name plate decal (includes pump serial number)
77	Hearing protection warning decal

REF. NO.	DESCRIPTION
79	Patent decal
80	Folding spanner wrench
90	Fuel tank subassembly (includes ref no. 41, 50 & 77)
128	Hex hd screw, 1/4-20 x 1/2 in.
134	Carbon monoxide warning label
148	Plain washer, 1/4 in.
165	Rubber bushing
166	Pan hd screw, 1/4-20 x 2-1/2 in.
169	Inlet chamber seal
175	Compression release decal
176	Hot warning decal
177	CE marking decal

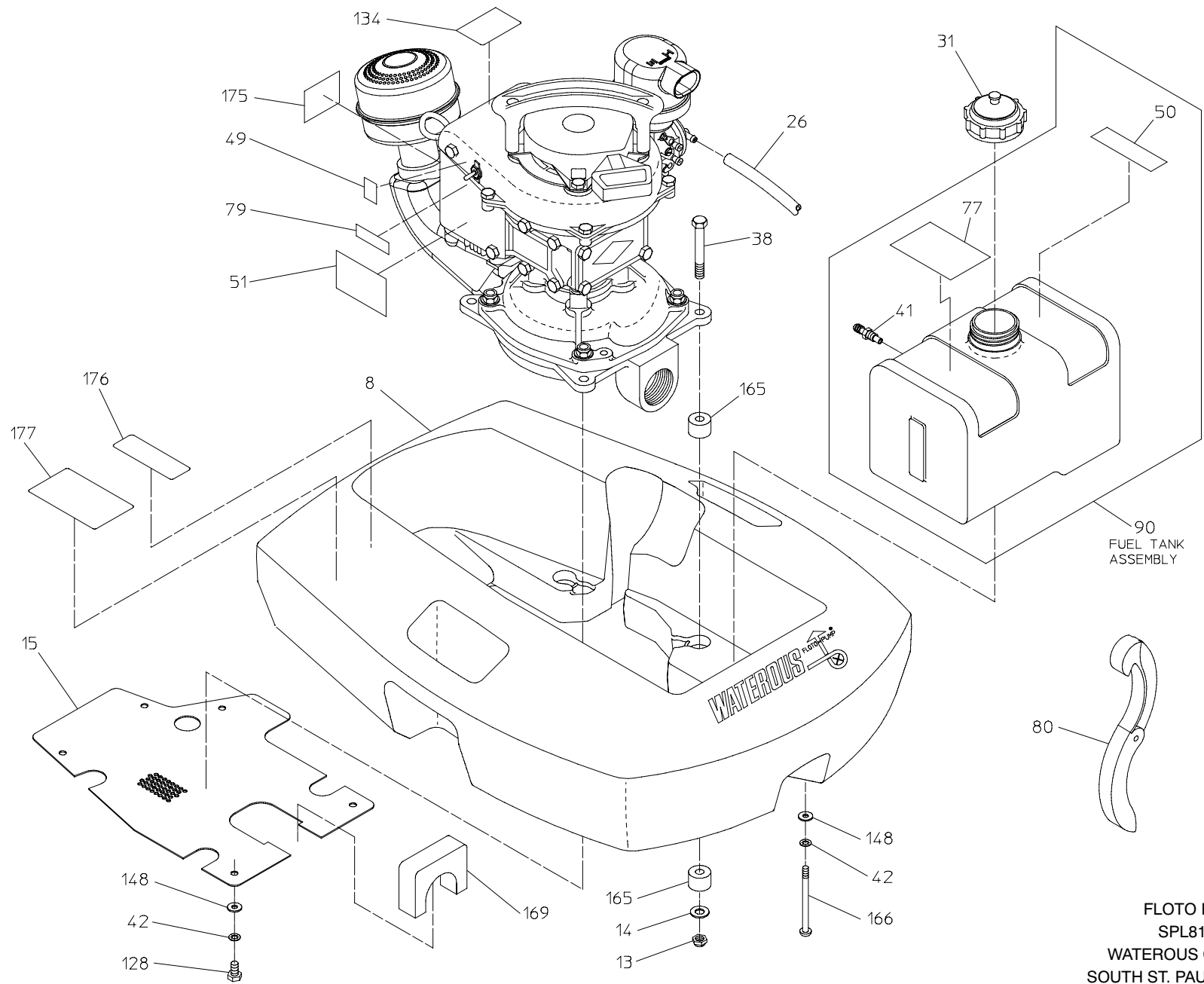

FLOAT AND FUEL SYSTEM

FLOTO PUMP
 SPL81995
 WATEROUS COMPANY
 SOUTH ST. PAUL, MN 55075
 PAGE 3 OF 13

Exhaust and Air Intake (Prior to July 21, 2006)

REF. NO.	DESCRIPTION
1	Air intake stack cap
2	Wing nut, no. 10-32
3	Internal tooth lock washer, no. 10
4	Plain washer, 3/16 in.
6	Lifting handle
7	Engine
23	Throttle control float
25	Throttle control arm
28	Socket hd screw, no. 10-32 x 3/8 in.
29	Socket hd screw, 1/4-20 x 2-1/2 in.
35	Self-locking nut, no. 10-24
42	Internal tooth lock washer, 1/4 in.
44	Muffler

REF. NO.	DESCRIPTION
45	Exhaust adapter
48	Choke decal (prior to May 19, 2003) Choke plate (after May 19, 2003)
53	U-bolt clamp
58	Self-locking nut, 1/4-20
65	Air intake stack
82	Muffler bracket
83	Hex hd screw, 5/16 x 1-1/4 in.
84	Lock plate
135	Hex hd screw, 1/4-20 x 5/8 in.
153	Lock washer, 1/4 in.
164	Conduit locknut, 1-1/4 in.
170	Fill hd screw, no. 10-24 x 9/16 in.

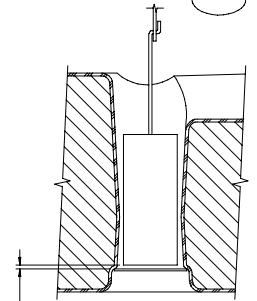
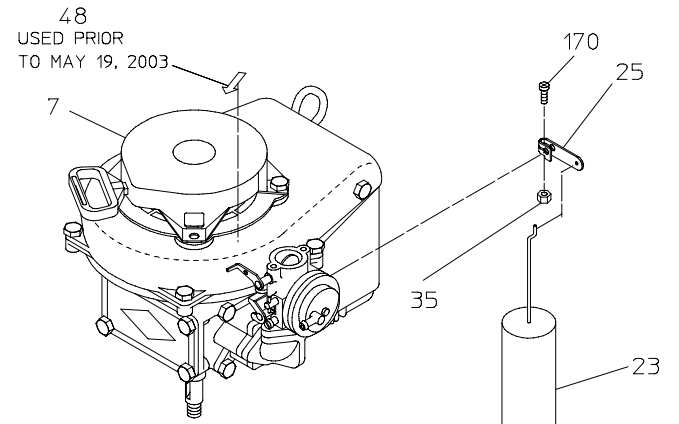
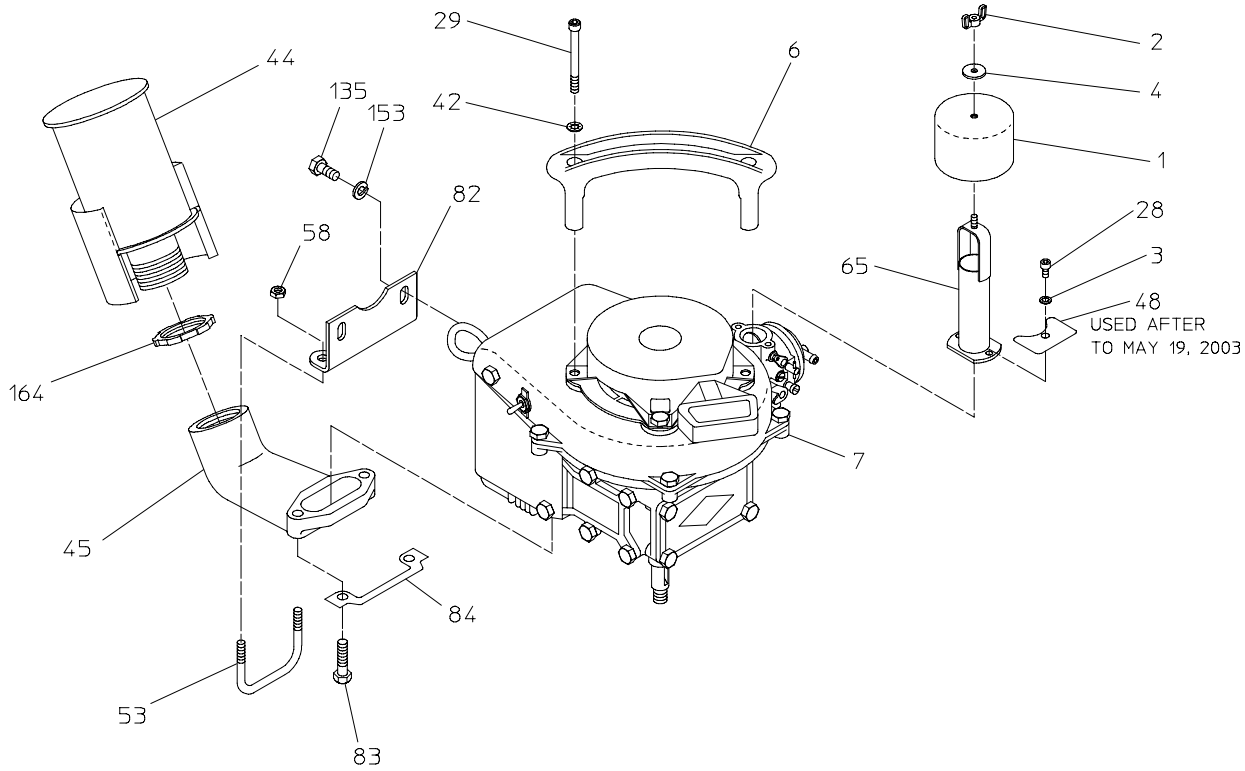

WITH THROTTLE CLOSED, SET THE THROTTLE CONTROL ARM SO THAT THE FLOAT COMES WITHIN 1/8 IN. OF THE SCREEN

EXHAUST AND AIR INTAKE PRIOR TO JULY 21, 2006

FLOTO PUMP
 SPL81995
 WATEROUS COMPANY
 SOUTH ST. PAUL, MN 55075
 PAGE 5 OF 13

Exhaust and Air Intake (After July 21, 2006)

REF. NO.	DESCRIPTION
1	Air intake cover
3	Internal tooth lock washer, no. 10
6	Lifting handle
7	Engine
21	Socket hd screw, 5/16-18 x 1-1/2 in.
23	Throttle control float
25	Throttle control arm
28	Socket hd screw, no. 10-32 x 3/8 in.
29	Socket hd screw, 1/4-20 x 2-1/2 in.
35	Self-locking nut, no. 10-24
42	Internal tooth lock washer, 1/4 in.

REF. NO.	DESCRIPTION
44	Muffler
45	Exhaust adapter
65	Air intake base
82	Muffler bracket
128	Hex hd screw, 1/4-20 x 1/2 in.
135	Hex hd screw, 1/4-20 x 5/8 in.
153	Lock washer, 1/4 in.
170	Fill hd screw, no. 10-24 x 9/16 in.
178	Pipe nipple, 1-1/4 NPT x 5 in.
179	Air intake screen

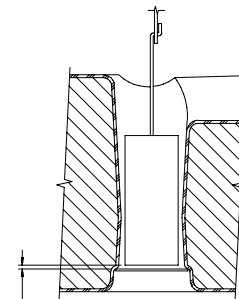
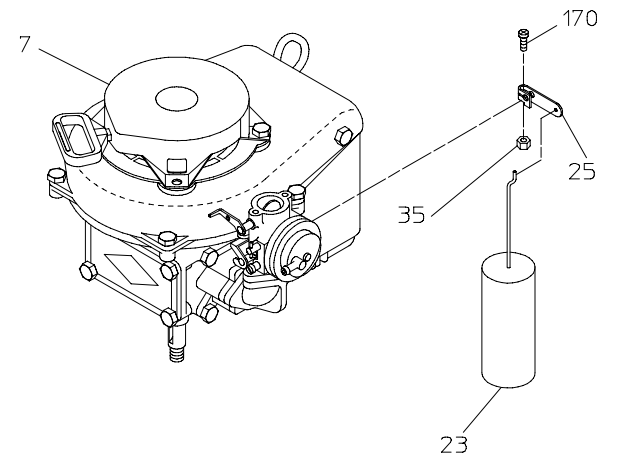
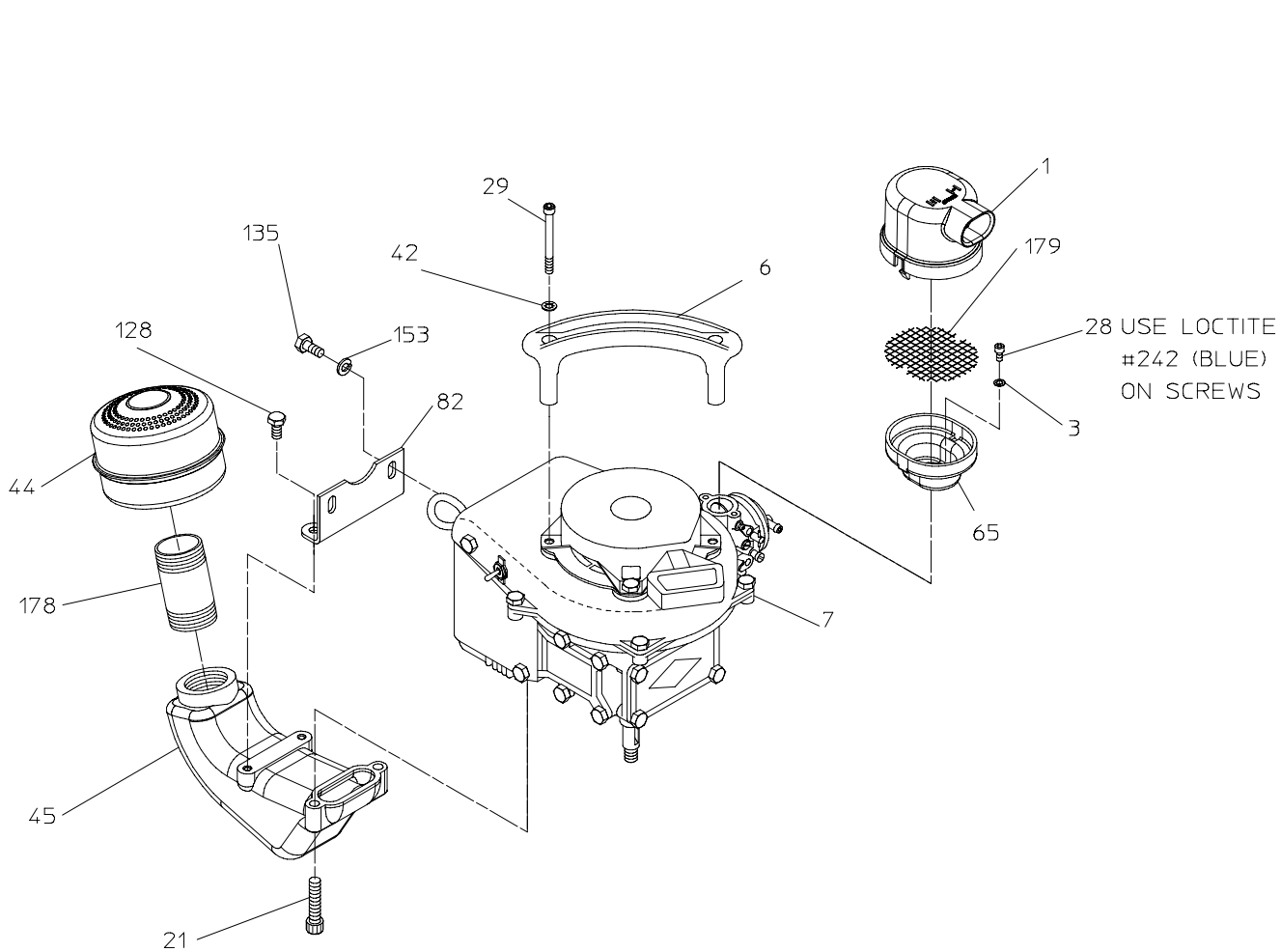

WITH THROTTLE CLOSED, SET THE THROTTLE CONTROL ARM SO THAT THE FLOAT COMES WITHIN 1/8 IN. OF THE SCREEN

EXHAUST AND AIR INTAKE AFTER JULY 21, 2006

FLOTO PUMP
 SPL81995
 WATEROUS COMPANY
 SOUTH ST. PAUL, MN 55075
 PAGE 7 OF 13

Pump

REF. NO.	DESCRIPTION
7	Engine
12	Hex hd screw, 3/8-16 x 1-1/2 in.
13	Self-locking nut, 3/8-16
14	Plain washer, 3/8 in.
16	Mechanical seal
17	Self-locking nut, 9/16-18
18	Impeller
19	Dowel pin, SS, 5/16 x 3/4 in.
20	Upper volute body

REF. NO.	DESCRIPTION
21	Socket hd screw, 5/16-18 x 1-1/2 in.
22	Lower volute body
36	Discharge nipple, 1-1/2 NPSH x 11 in., or 1-1/2 BSP x 11 in., or 1-1/2 NPT x 8-7/8 in. (1-1/2 NPT x 8-7/8 in. nipple requires ref. no. 37 nozzle)
37	Discharge nozzle, 1/1/2 NH (not used with ref. no. 36 NPSH or BSP discharge nipples)
46	O-ring, 7/1/4 x 7-1/2 in.
131	Woodruff key

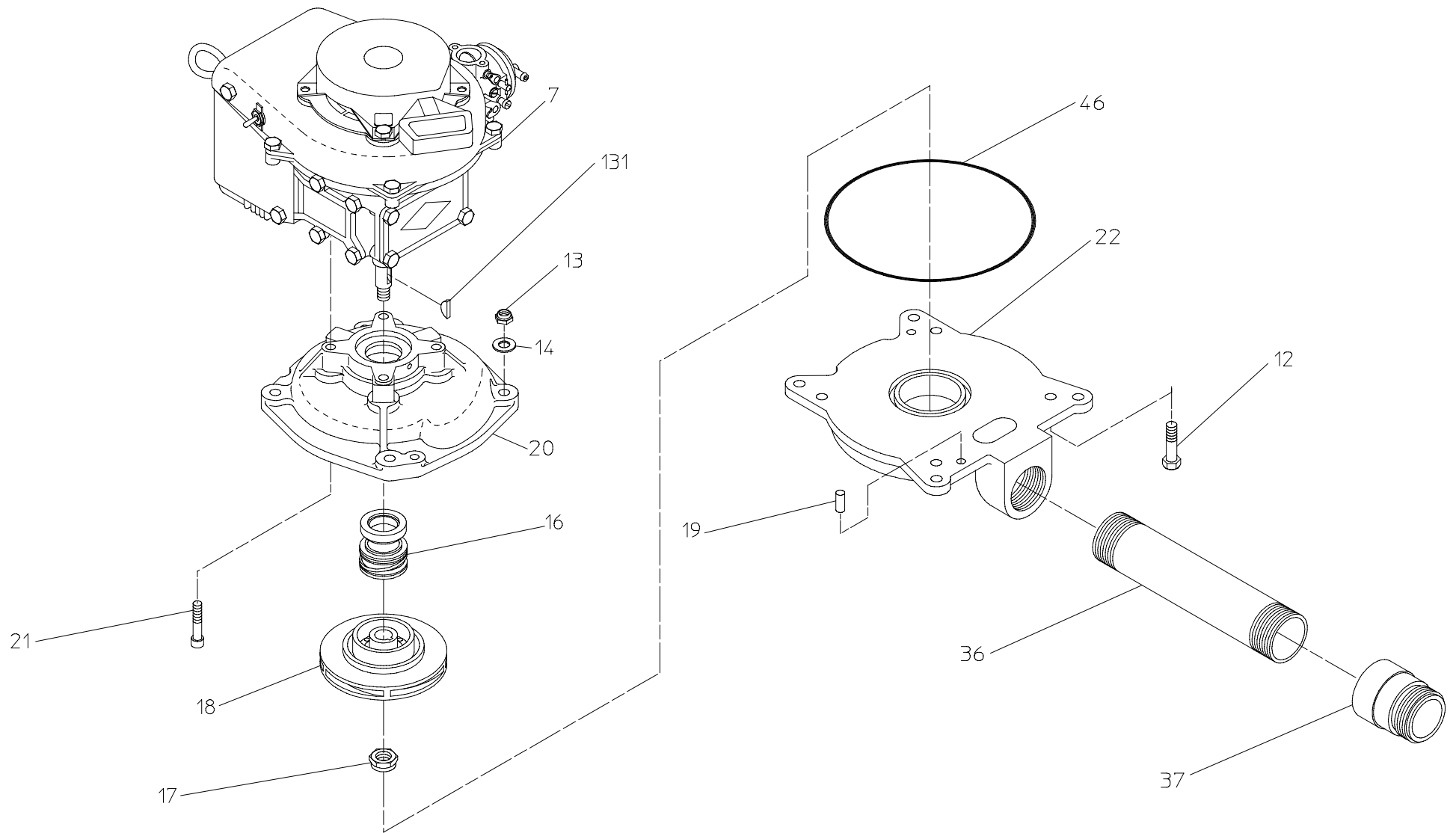

PUMP

Engine - Starter and Ignition

REF. NO.	DESCRIPTION
85	Cylinder cover
86	Fan housing
87	Support plate
88	Coil wedge spring
89	Coil with sparkie
91	Ignition switch
93	Starter
95	Flywheel key
98	Magneto end seal
99	Stator plate assembly
127	Hex hd cap screw with lockwasher, 1/4-20 x 5/8 in.
128	Hex hd cap screw with lockwasher, 1/4-20 x 1/2 in.
135	Hex hd screw, 1/4-20 x 5/8 in.

REF. NO.	DESCRIPTION
136	Hex nut, 7/16-20
138	Starter cup
139	Flywheel
141	Ground lead
142	Hex slot screw with lockwasher, 1/4-20 x 11/16 in.
144	Insulator
148	Plain washer, 1/4 in.
156	Pan hd screw, 6-32 x 3/8 in.
157	Insulator screw
159	Self-locking nut, no. 6-32
167	Atom module assembly
171	Power head gasket and seal set
172	Spacer

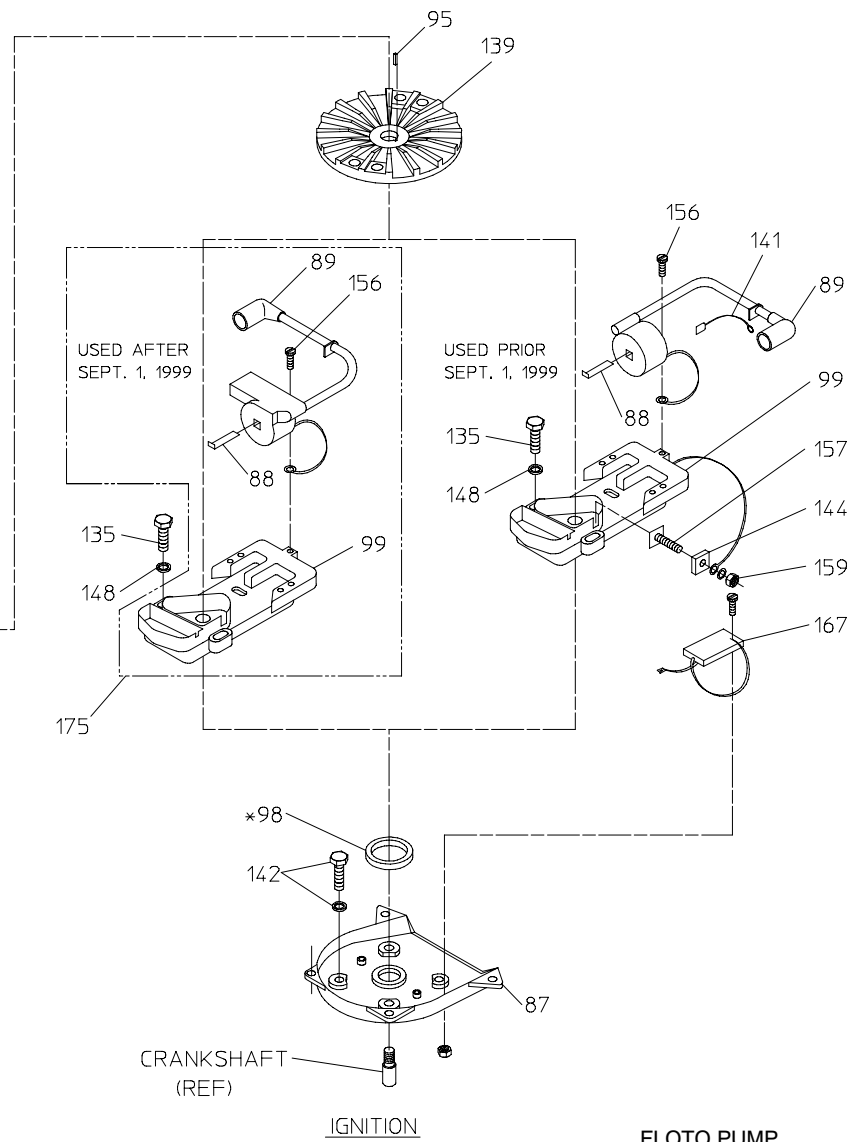
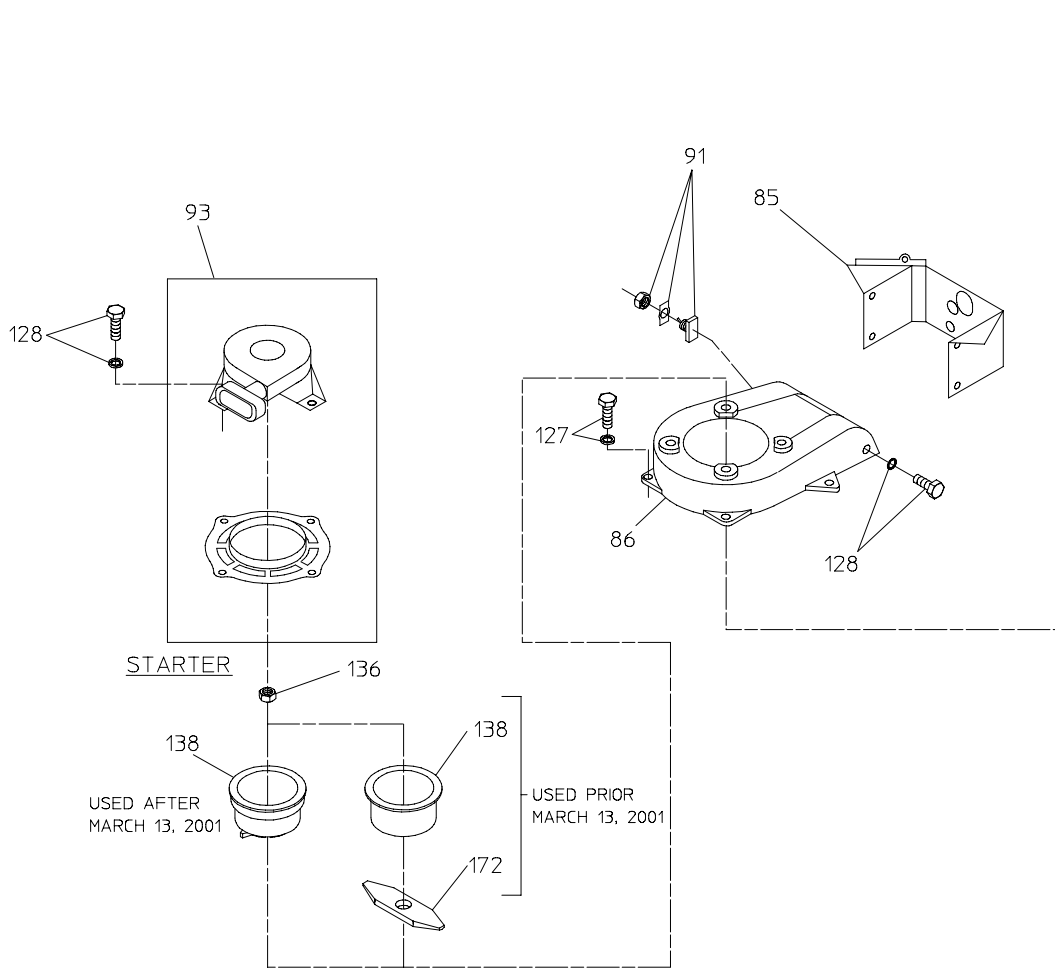

NOTE: ENGINE PARTS DESIGNATED BY A REF. NO. CAN BE SUPPLIED BY WATEROUS COMPANY OR A U.S. MOTOR POWER BEE DISTRIBUTOR OR DEALER. PARTS WITHOUT A REF. NO. CAN BE SUPPLIED BY U.S. MOTOR POWER ONLY. SEE U.S. MOTOR POWER'S SERVICE MANUAL FOR INFORMATION ON OBTAINING THESE PARTS.

*INCLUDED IN GASKET REPAIR KIT REF NO. 171 (ALSO SEE POWER HEAD DETAIL)

FLOTO PUMP
SPL81995
WATEROUS COMPANY
SOUTH ST. PAUL, MN 55075
PAGE 11 OF 13

Engine - Carburetor and Power Head

REF. NO.	DESCRIPTION
56	Complete carburetor
57	Carburetor gasket
69	Manifold gasket
70	Transfer port cover gasket
71	Carburetor stud
74	Spark plug (Champion L-86C or AC R44 F)
75	Carburetor adapter elbow
76	Manifold
81	Head bolt stud
94	Carburetor repair parts kit
101	Fuel strainer cover
102	Main adjustment screw washer
103	Throttle shaft and lever
104	Bearing cage gasket
105	Ball bearing
106	Crankshaft
107	Connecting rod with cap
108	Retaining ring
109	Piston
110	Piston pin
111	Piston ring set
112	Cylinder head
113	Head gasket, .032 in. thick
114	Head gasket, .062 in. thick

REF. NO.	DESCRIPTION
115	Cylinder with seal
116	Reed
117	Drive end seal
118	Crankcase cover gasket
119	Transfer port cover
120	Connecting rod screw
121	Crankpin roller set
123	Hex hd screw with lockwasher, 1/4-20 x 3/4 in.
124	Hex hd screw with lockwasher, 1/4-20 x 7/8 in.
125	Hex hd screw with lockwasher, 1/4-20 x 1-1/8 in.
130	Hex nut, 1/4-20
149	Crankcase cover
150	Reed stop
151	Round hd screw with lockwasher, no. 6-32 x 5/16 in.
152	Reed plate (includes 116, 150 & 151)
153	Spring lockwasher, 1/4 in.
154	Socket hd cap screw, 1/4-20 x 1 in.
155	Plain washer, 1/4 in.
160	Fuel stainer screen
161	Fuel strainer cover gasket
162	Hex hd screw, 6-32 x 7/16 in.
171	Power head gasket and seal set
173	Compression release valve
174	Washer

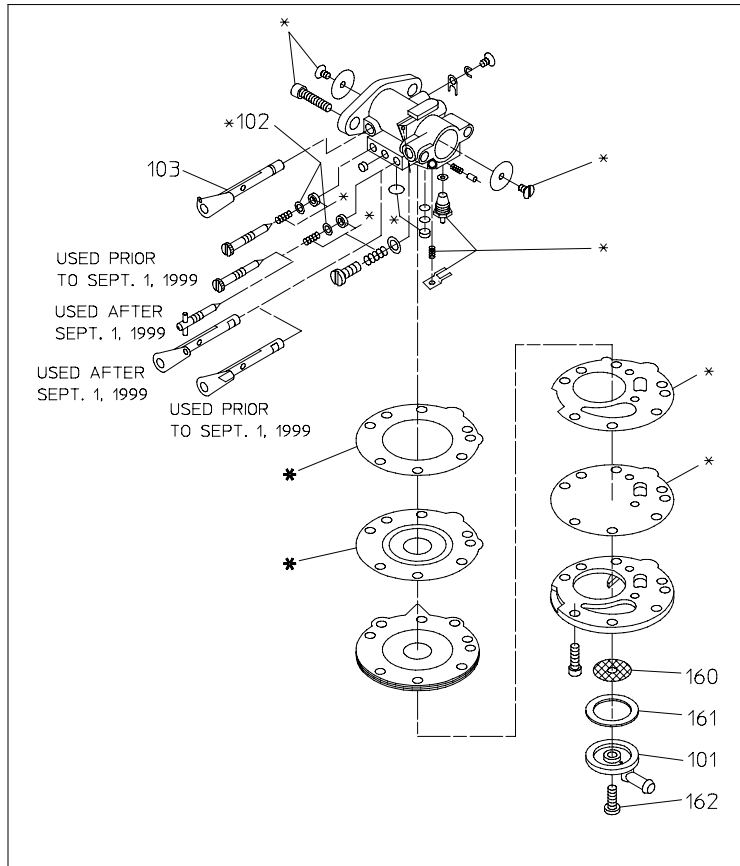

56 COMPLETE CARBURETOR KIT (INCLUDES (3) REF NO. 57 GASKETS, SEE POWER HEAD DETAIL)

CARBURETOR KIT 94

*INCLUDED IN CARBURETOR REPAIR KIT REF NO. 94

CARBURETOR

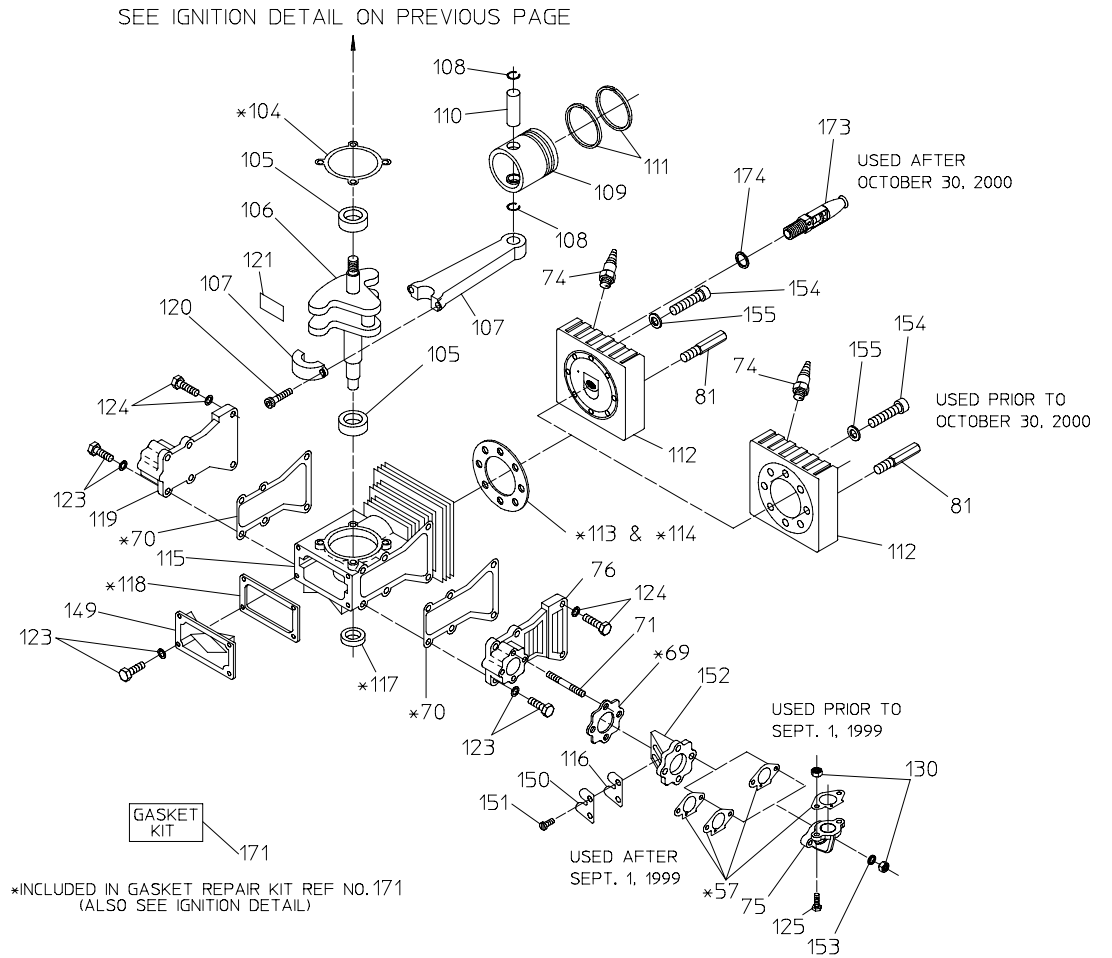

*INCLUDED IN GASKET REPAIR KIT REF NO. 171 (ALSO SEE IGNITION DETAIL)

POWER HEAD