



Document Number	Issue Date	Rev. Date
<b>SPL82020</b>	<b>09/20/94</b>	<b>02/02/12</b>

## PB18 Series Portable Pump Assembly Service Parts List

### Index:

Component	Pump Model <i>(Located on Pump Serial Plate)</i>	See Page
Pump Assembly	PB18-2515, PB18-2515B	2, 3
	PB18-3030, PB18-3030C	4, 5
	PB18-3030E	
	PB18-3025E	
		PB18-3025A
Engine and Primer	All	8, 9
Primer Control	All	10, 11
Ignition Switch	All	
Wiring Diagram	All	12, 13
Fuel Line Connection	All	
Instrument Panel (Optional)	All	14, 15
Fuel Tank	All	16, 17

## Pump Assembly, Models PB18-2515 and PB18-2515B

REF. NO.	DESCRIPTION
1	Drain Cock
2	Serial Plate
3	Round Head Drive Screw, No. 6 x 1/4 in.
9	O-ring, 7-3/4 x 8 in.
11	Shaft Sleeve
12	O-ring, 1 x 1-1/8 in.
13	Primer Tube
14	Compression Connector, 3/8 x 1/4 in.
20	Hex Head Screw, 1/4-20 x 3/4 in.
21	Lock Washer, 1/4 in.
26	Hex Head Screw, 1/4-20 x 1-1/4 in.
33	Square Key, 1/4 x 3/4 in. SS
34	Hex Head Screw, 3/8-16 x 1 in.
35	Lock Washer, 3/8 in.
36	Engine Adapter Subassembly (Includes 39)
37	Copper Washer, 3/8 in.
38	Socket Head Screw, 3/8-16 x 2 in.
39	Wear Ring
40	Mechanical Seal
41	Impeller
42	Clamp Washer
43	Socket Head Screw, 3/8-24 x 1 in., SS

REF. NO.	DESCRIPTION
44	Volute Body Subassembly (Includes 2, 3 & 39)
45	Headless Pip Plug, 1/4 in.
46	Compression Elbow, 90 Degree
47	Ball Valve, 1/4 in.
48	Pipe Nipple, 1/4 x 1-1/2 in.
56	Ball Valve, 1-1/2 NH or 1-1/2 NPT
91	O-ring
101	Discharge Adapter
102	Cap and Chain
103	Discharge Adapter
104	Intake Adapter
129	Pressure Gauge Hose
141	Tube Connector, 1/4 x 1/4 in.
159	Ball Valve Adapter
160	Hex Nut, 1/4-20
237	Pipe Nipple, 1/4 x 7/8 in.
238	Pipe Tee, 1/4 in.
246	Compound Gauge Hose

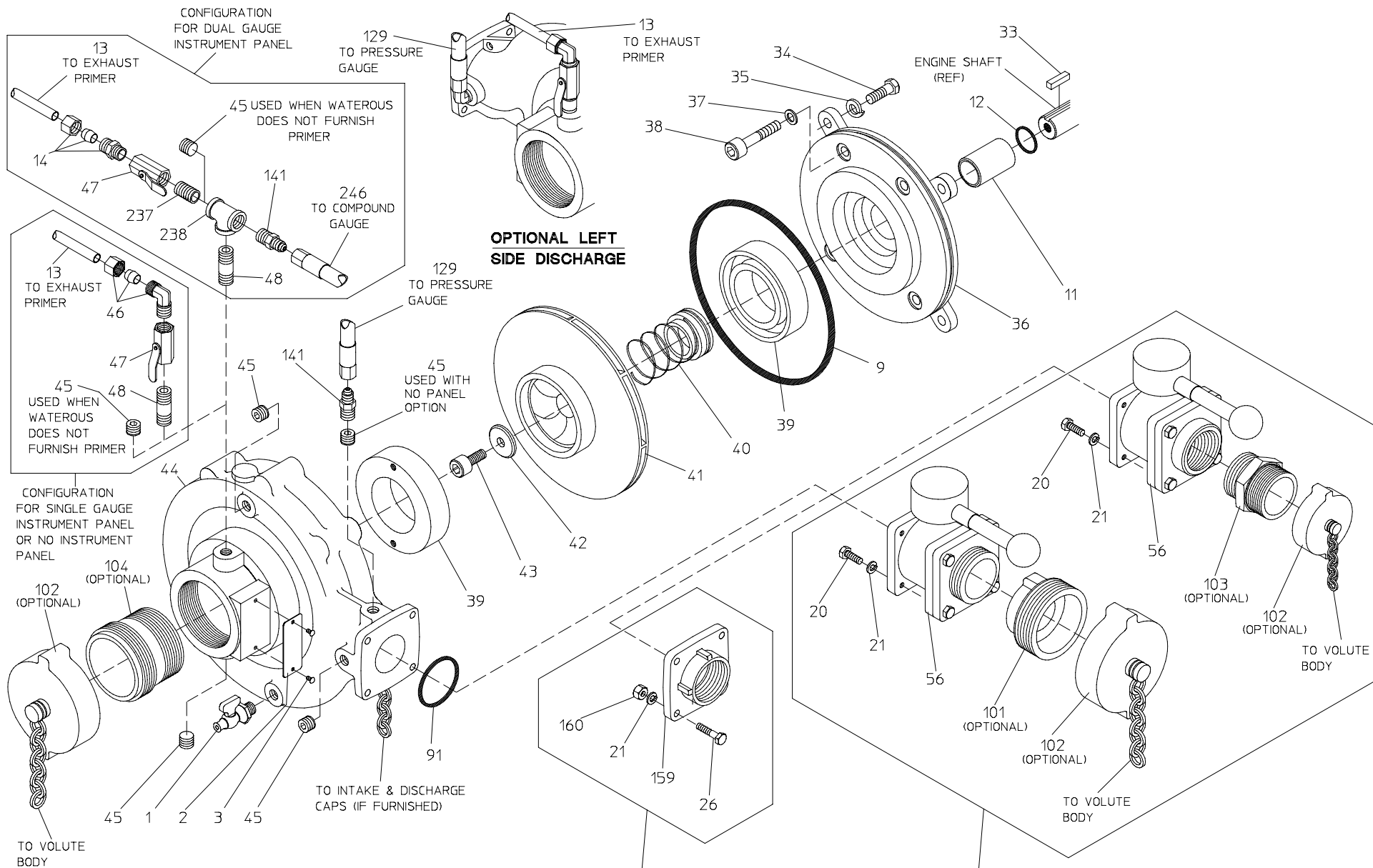

**PUMP ASSEMBLY FOR  
MODELS PB18-2515 & PB18-2515B**

**MODEL PB18-2515**

**MODEL PB18-2515B**

## Pump Assembly, Models PB18-3025E, PB18-3030, PB18-3030C, and PB18-3030E

REF. NO.	DESCRIPTION
1	Drain Cock
2	Serial Plate
3	Round Head Drive Screw, No. 6 x 1/4 in.
9	O-ring, 7-1/4 x 7-1/2 in.
11	Shaft Sleeve
12	O-ring, 1 x 1-1/8 in.
13	Primer Tube
14	Compression Connector, 3/8 x 1/4 in.
33	Square Key, 1/4 x 3/4 in. SS
34	Hex Head Screw, 3/8-16 x 1 in.
35	Lock Washer, 3/8 in.
36	Engine Adapter Subassembly (Includes 39)
37	Copper Washer, 3/8 in.
38	Socket Head Screw, 3/8-16 x 2 in.
39	Wear Ring
40	Mechanical Seal
41	Impeller
42	Clamp Washer
43	Socket Head Screw, 3/8-24 x 1 in., SS
44	Volute Body Subassembly (Includes 2, 3 and 39)

REF. NO.	DESCRIPTION
45	Headless Pip Plug, 1/4 in.
46	Compression Elbow, 90 Degrees
47	Ball Valve, 1/4 in.
48	Pipe Nipple, 1/4 x 1-1/2 in.
102	Cap and Chain
103	Discharge Adapter
104	Intake Adapter
129	Pressure Gauge Hose
141	Tube Connector, 1/4 x 1/4 in.
155	Discharge Gasket
156	Elbow, 3 NPT
158	Hex Head Screw, 5/16-18 x 1 in.
161	Check Valve
171	Male Elbow, 90 Degrees
237	Pipe Nipple, 1/4 x 7/8 in.
238	Pipe Tee, 1/4 in.
247	Discharge WYE With Ball Valves
254	Discharge Extension, 3 NPT
255	O-ring, 3-5/8 x 3-7/8 in.

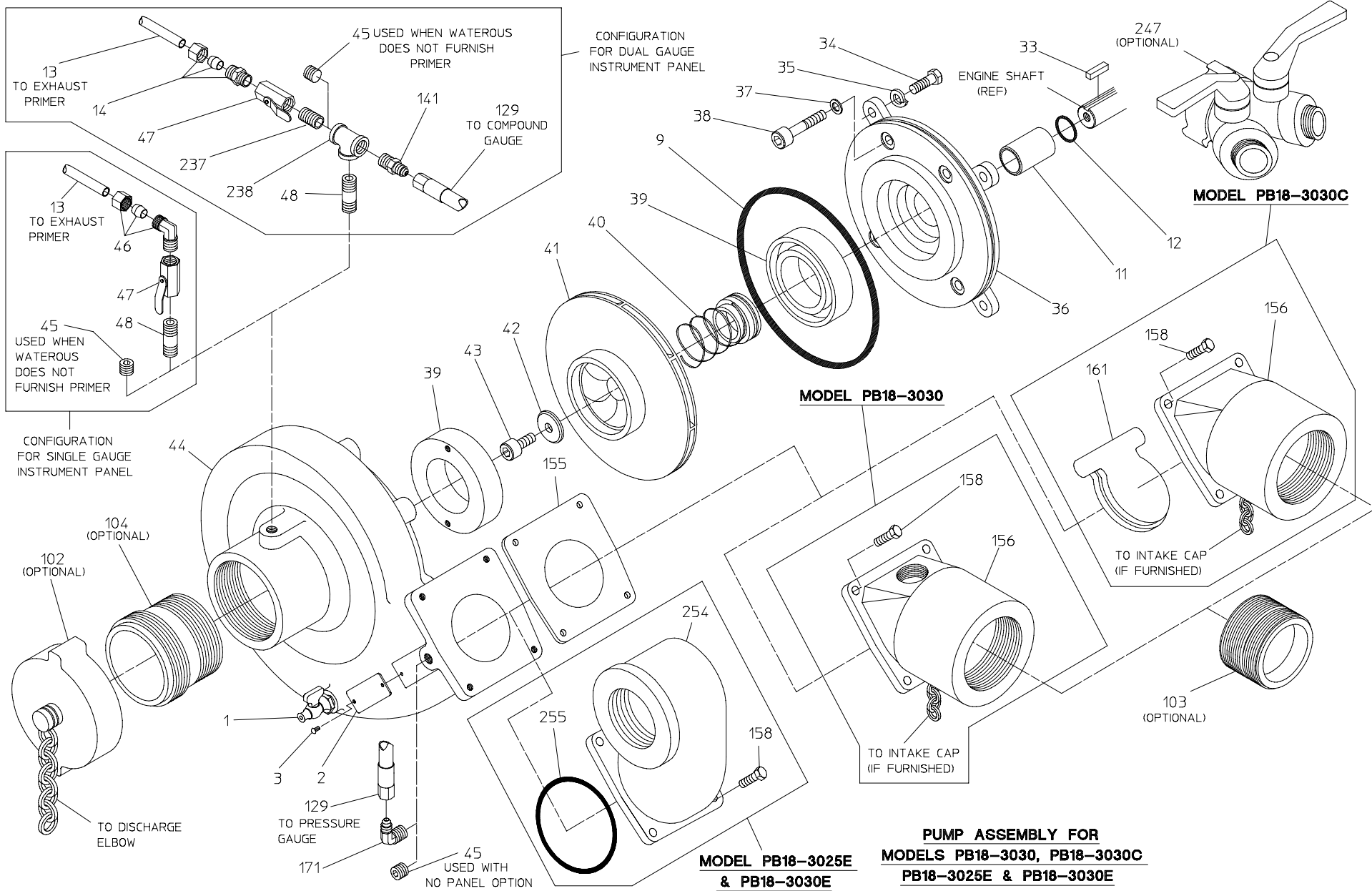

## Pump Assembly, Models PB18-3025A

REF. NO.	DESCRIPTION
1	Drain Cock
2	Serial Plate
3	Round Head Drive Screw, No. 6 x 1/4 in.
9	O-ring, 7-1/4 x 7-1/2 in.
11	Shaft Sleeve
12	O-ring, 1 x 1-1/8 in.
13	Primer Tube
14	Compression Connector, 3/8 x 1/4 in.
33	Square Key, 1/4 x 3/4 in. SS
34	Hex Head Screw, 3/8-16 x 1 in.
35	Lock Washer, 3/8 in.
36	Engine Adapter Subassembly (Includes 39)
37	Copper Washer, 3/8/ in.
38	Socket Head Screw, 3/8-16 x 2 in.
39	Wear Ring
40	Mechanical Seal
41	Impeller

REF. NO.	DESCRIPTION
42	Clamp Washer
43	Socket Head Screw, 3/8-24 x 1 in., SS
44	Volute Body Subassembly (Includes 2, 3 and 39)
45	Headless Pipe Plug, 1/4 in.
47	Ball Valve, 1/4 in.
48	Pipe Nipple, 1/4 x 1-1/2 in.
129	Pressure Gauge Hose
158	Hex Head Screw, 5/16-18 x 1 in.
171	Male Elbow, 90 Degree
237	Pipe Nipple, 1/4 x 7/8 in.
238	Pipe Tee, 1/4 in.
239	O-ring, 93 mm x 99 mm
240	Socket Head Screw, 5/16-18 x 1-1/4 in.
241	2-1/2 in. BSP Discharge Valve
243	Discharge Valve Adapter

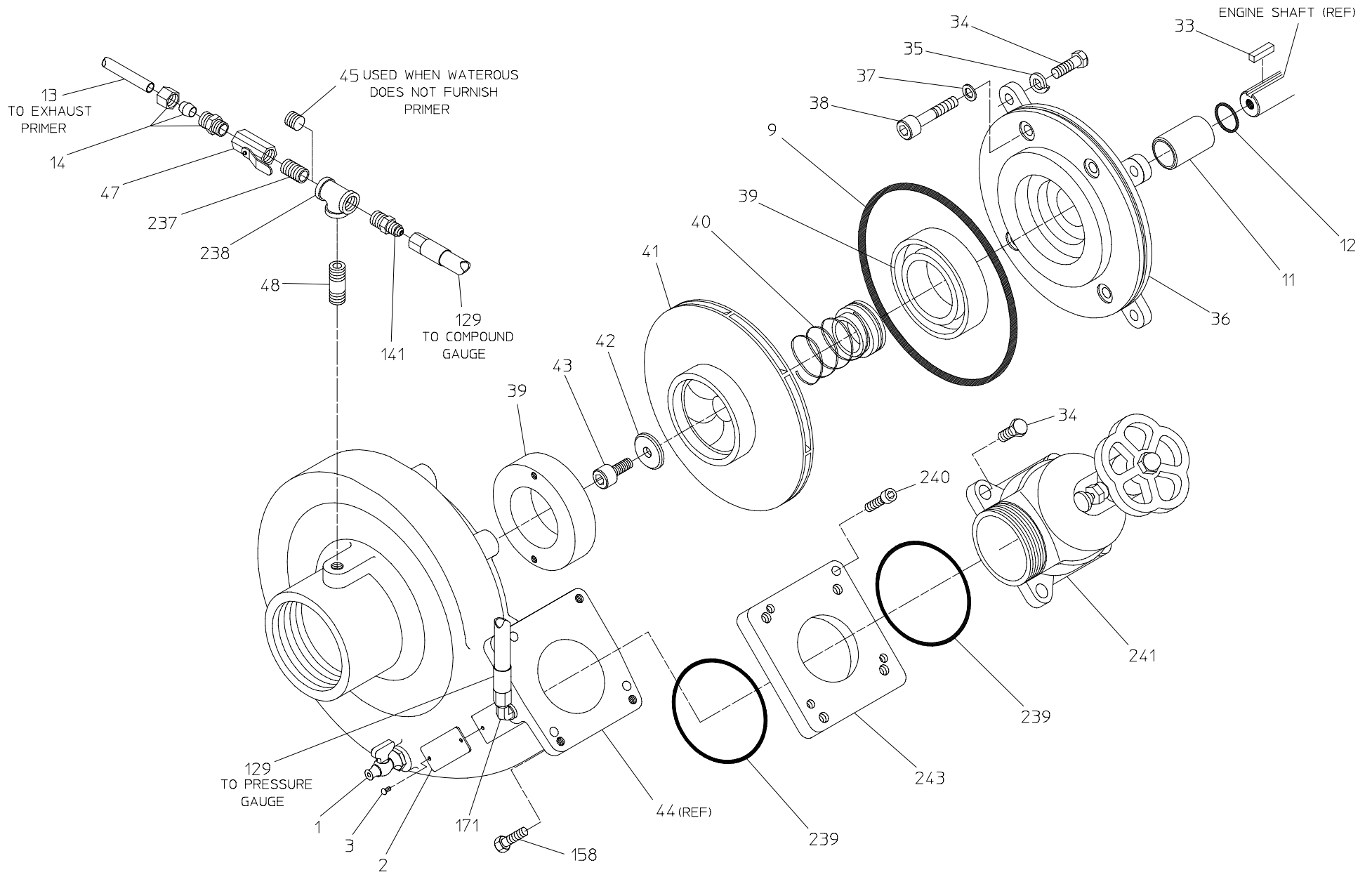

**PUMP ASSEMBLY FOR MODEL PB18-3025A**  
 (NOT AVAILABLE WITH NO PANEL OPTION)

## Engine and Primer

REF. NO.	DESCRIPTION
13	Primer Tube
14	Compression Connector, 3/8 x 1/4 in.
15	Exhaust Primer Subassembly
46	Compression Elbow, 90 Degree
53	18 HP Engine Replacement Kit
94	Muffler
95	Primer
114	Spark Arrestor
119	Instrument Panel
131	Hex Head Screw, 1/4-20 x 3/4 in.
153	Pump Decal
200	Warning Label
215	Hose Clamp
216	Extension Tube
220	Butterfly Valve

REF. NO.	DESCRIPTION
221	Butterfly Shaft
222	Butterfly Rod Linkage
225	Muffler Guard
226	Spirol Pin, 1/8 x 5/16 in.
227	Pan Head Screw, 8-32 x 3/8 in.
230	Lock Washer, No. 8
231	Set Screw, 1/4-20 x 1/2 in.
232	Self Tapping Hex Head Screw, #6 x 1/2 in. or Pan Head Screw, #10-24 x 1/2 in.
233	Plain Washer, 3/8 in.
234	Muffler Screw
235	Muffler Gasket
236	Guard Screw
244	Street Elbow, 90 Degree, 1/2 NPT



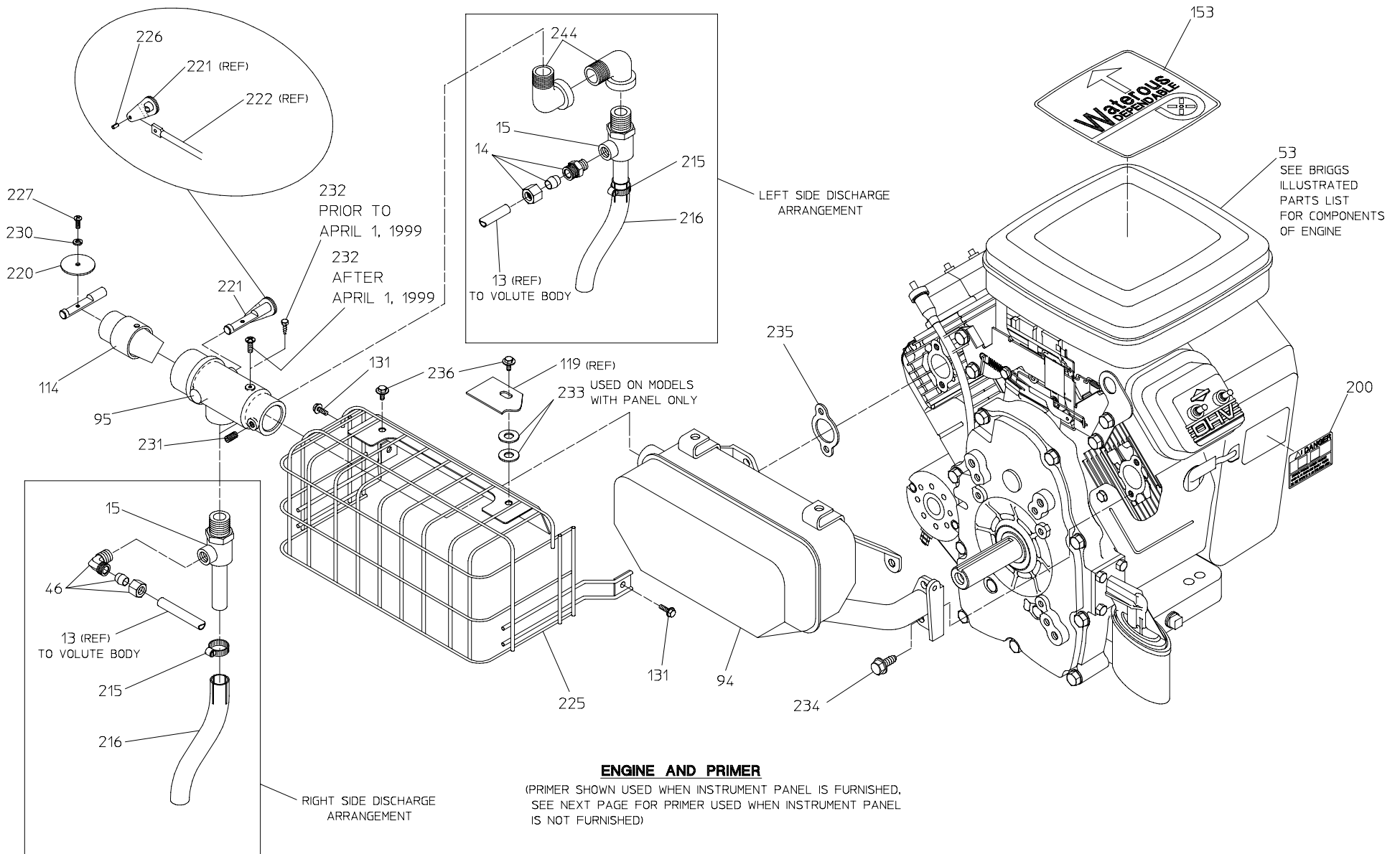

## Primer Control and Ignition Switch

REF. NO.	DESCRIPTION
61	Nylok Nut, 1/4-20
63	Pan Head Screw, 1/4-20 x 3/4 in.
94	Muffler
131	Hex Head Screw, 1/4-20 x 3/4 in.
222	Butterfly Rod Linkage
223	Compression Spring
224	Push/Pull Knob
225	Muffler Guard

REF. NO.	DESCRIPTION
228	Wire Protector
229	Plain Waher, 1/4 in.
236	Guard Screw
249	Primer Rod Support
250	Fender Washer, 1/4 in.
251	Ignition Switch
252	Wiring Harness
253	Ignition Switch Knob

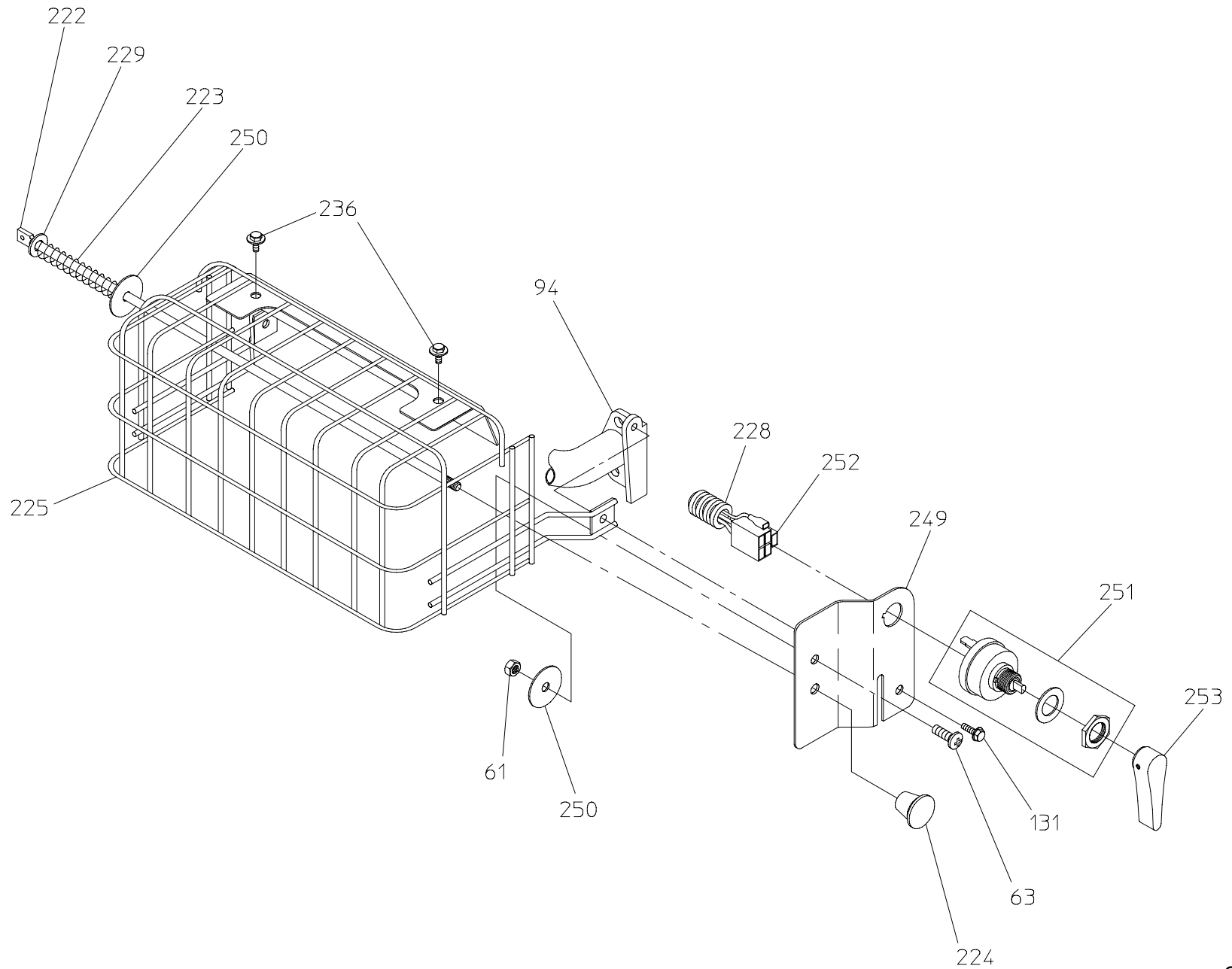

**PRIMER CONTROL & IGNITION SWITCH**  
 (MODELS WITHOUT PANEL)

## Wiring Diagrams and Fuel Line Connection

REF. NO.	DESCRIPTION
119	Instrument Panel
122	Black Battery to Ground Wire
123	Black Off Switch to Ground Wire
124	Black Off Switch to Magneto Wire
125	Fuel Fitting, 3/8 in.
126	Fuel Line
136	Off Switch
137	Start Switch
138	Hose Clamp
172	Cable Clamp
180	Red Battery to Solenoid Wire
182	Red Solenoid to Start Switch Wire
183	Red Start Switch to Light Switch Wire
184	Red Light Switch to Light Wire

REF. NO.	DESCRIPTION
185	Black Light to Ground Wire
186	Orange Solenoid to Start Switch Wire
190	Light Switch
193	Panel Light
201	Black Indicating Light to Oil Pressure Switch Wire
202	Yellow Alternator to Indicating Light Wire
203	Red Indicating Light
204	Oil Pressure Switch
219	Red 18 Gauge Wire
228	Wire Protector
233	Plain Washer, 3/8 in.
245	Diode
248	12 Volt Battery
249	Primer Rod Support
251	Ignition Switch
252	Wiring Harness
253	Ignition Switch Knob

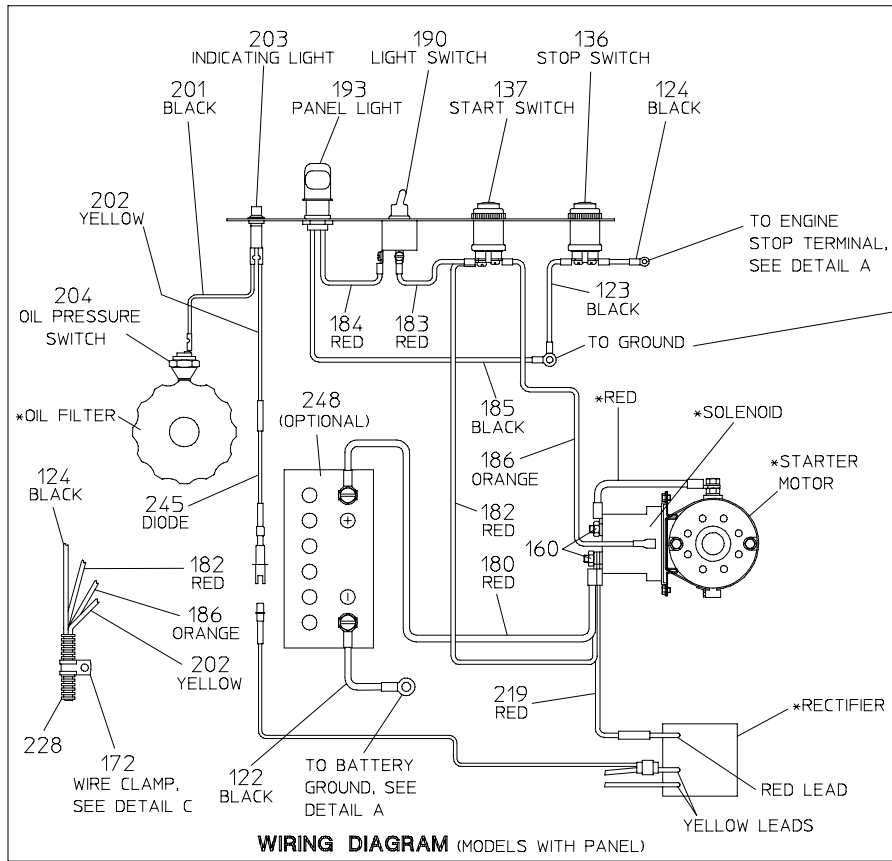

\* THESE PARTS NOT AVAILABLE FROM WATEROUS.  
SEE AN AUTHORIZED BRIGGS & STRATTON SERVICE DEALER.

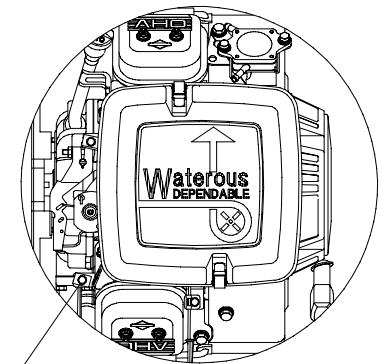
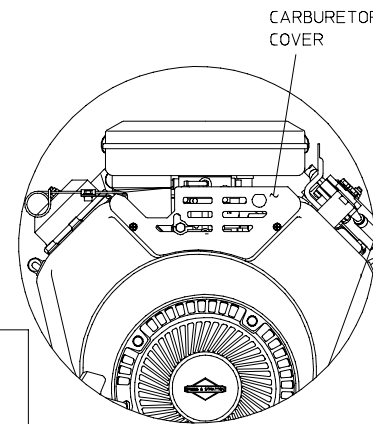
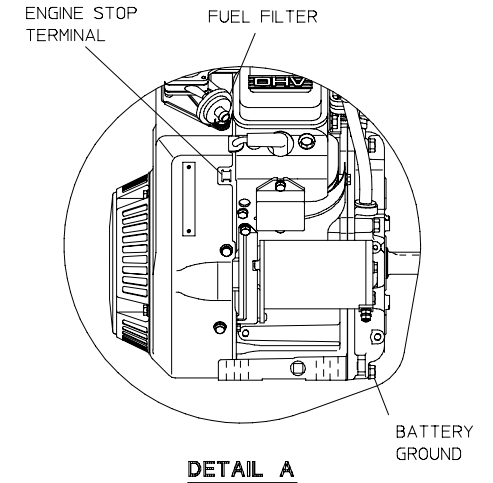
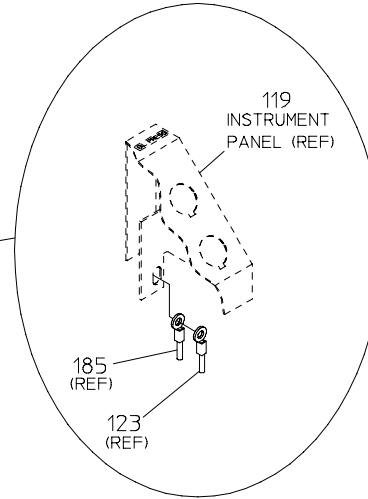
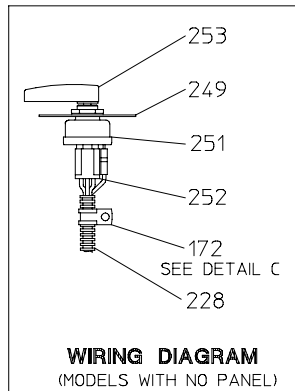
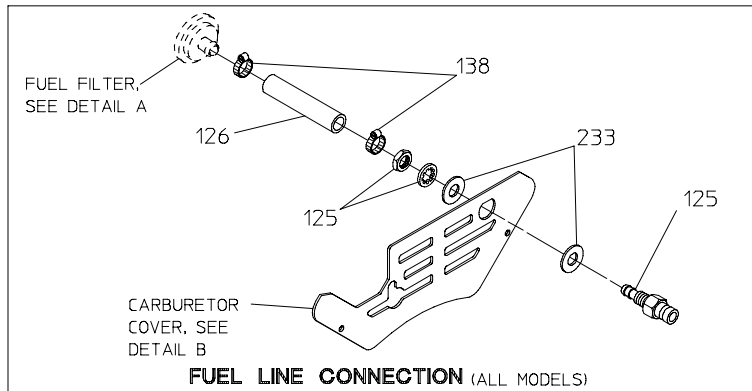

**WIRING DIAGRAMS & FUEL LINE CONNECTION (ALL MODELS)**

## Optional Instrument Panel

REF. NO.	DESCRIPTION
119	Instrument Panel
127	Pressure Gauge, 300 lb.
129	Pressure Gauge Hose
135	Switch Seal
136	Off Switch
137	Start Switch
139	Galvanized Pipe Elbow, 90 Degree, 1/4 in.
189	Panel Plate
190	Light Switch
192	12 Volt Bulb, No. 68
193	Panel Light

REF. NO.	DESCRIPTION
203	Red Indicating Light
205	Oil Pressure Decal
222	Butterfly Rod Linkage
223	Compression Spring
224	Push/Pull Knob
229	Plain Washer, 1/4 in.
242	Compound Gauge
246	Compound Gauge Hose

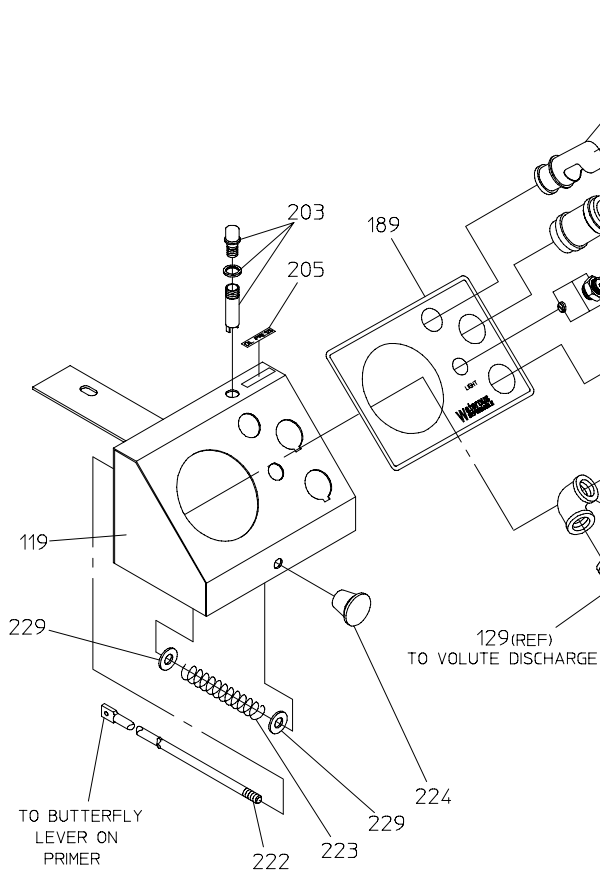

**SINGLE GAUGE INSTRUMENT PANEL**

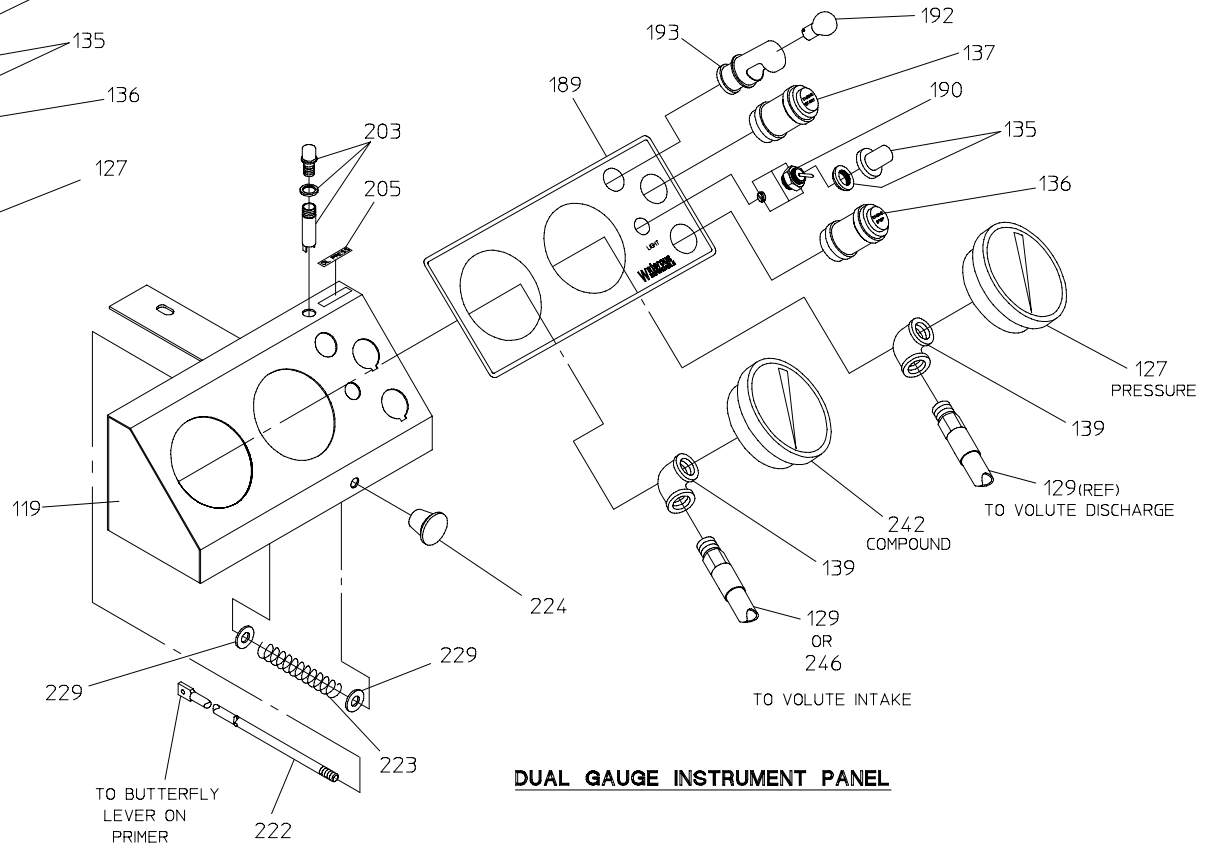

**DUAL GAUGE INSTRUMENT PANEL**

**OPTIONAL INSTRUMENT PANEL**  
(ALL MODELS)

## Fuel Tank

REF. NO.	DESCRIPTION
7	Lock Washer, 5/16 in.
20	Hex Head Scre, 1/4-20 x 3/4 in.
57	Hex Head Screw, 5/16-18 x 1-3/4 in. or 2-3/4 in.
58	Rail Base
60	Hex Nut, 5/16-18
61	Nylok Nut, 1/4-20
62	Rubber Foot
63	Pan Head Screw, 1/4-20 x 3/4 in.
64	Handle Grip
65	Pick Up Handle
66	Compression Spring
69	Foot Spacer
70	Pan Head Screw, 1/4-20 x 2-1/4 in.
92	Spring Pin, 3/16 x 1-1/4 in., SS

REF. NO.	DESCRIPTION
109	Hex Head Screw, 1/4-20 x 1 in.
110	Litter Base
111	End Frame
112	Side Frame
138	Hose Clamp
147	Fuel Tank Subassembly (Includes 138, 211, 212, 213, 214 & 256)
148	Battery Holder
149	Battery Hold Down
151	Curved Flange Tee Nut
168	Button Plug
211	Fuel Tank
212	Hose Connector
213	Fuel Line Kit
214	Quick-Release Connector
217	Spacer, 1 in.
248	12 Volt Battery
256	Fuel Cap



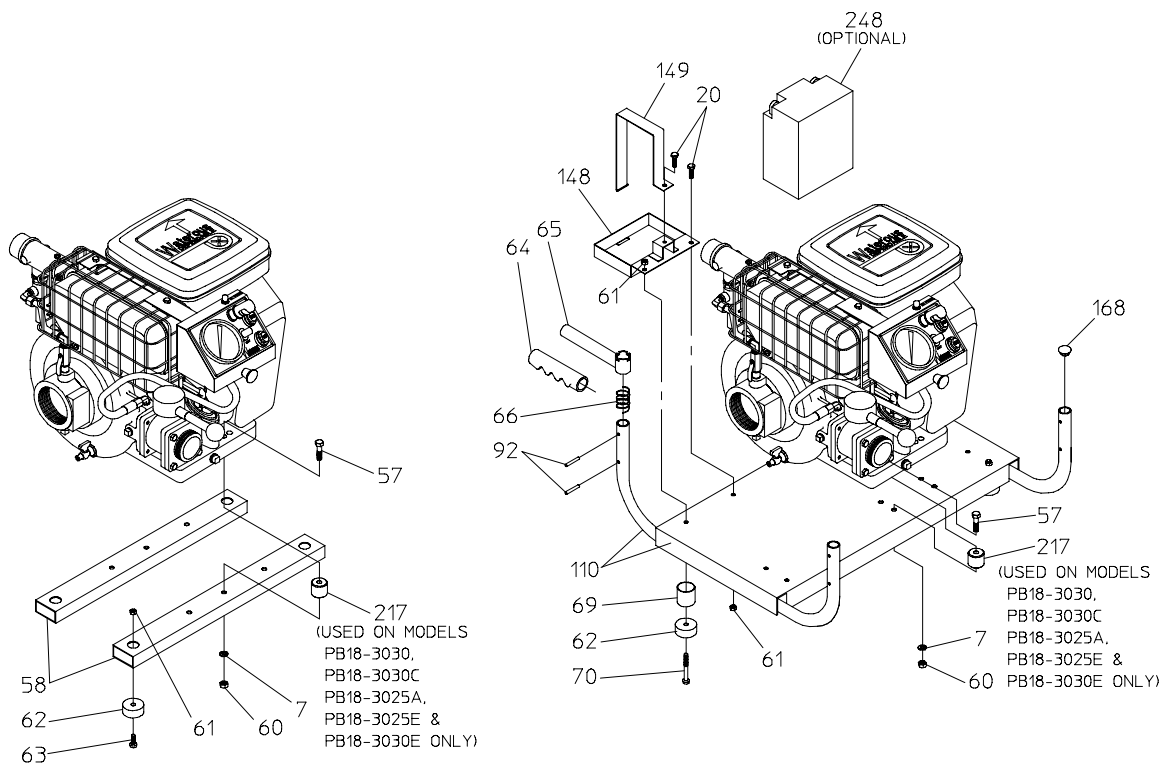

**RAIL BASE**

**LITTER BASE**

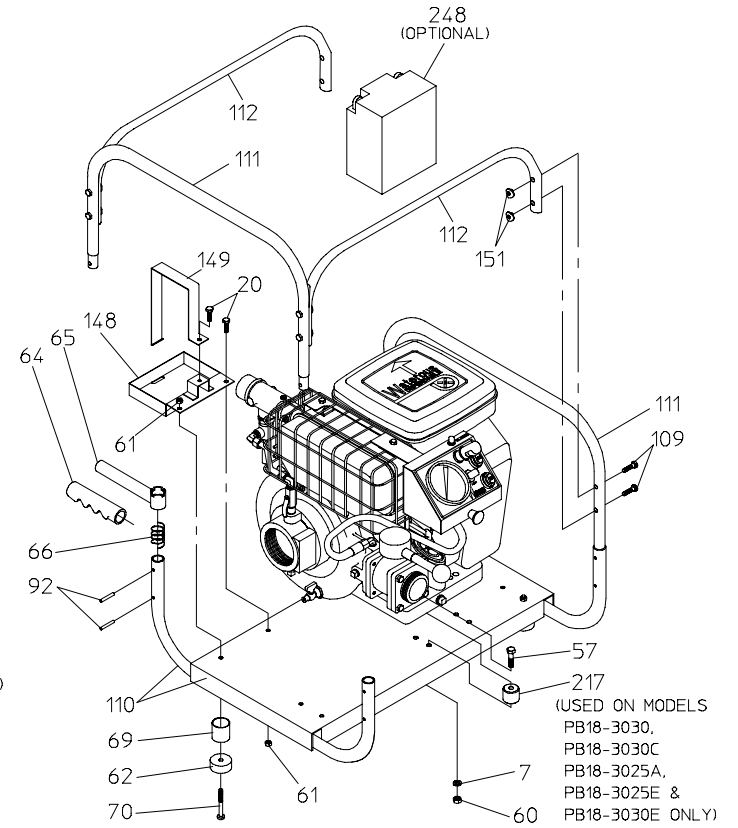

**WRAP-AROUND BASE**

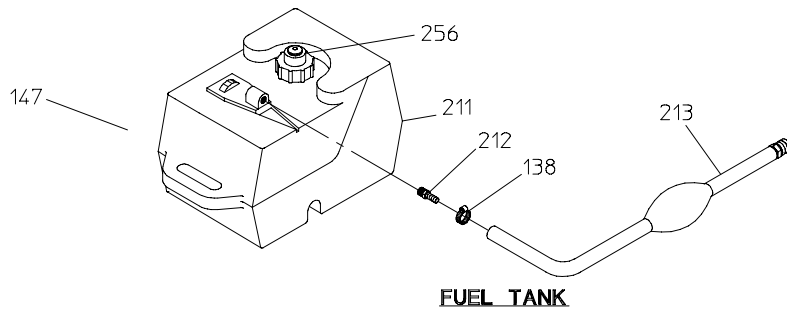

**FUEL TANK**