

CZ Series Pump Impeller Shaft Service Parts List

Index:

View	See Page
Exploded View	2, 3
Cross Section View	4, 5

Exploded View

Ref No.	Description
S1	Impeller
S2	Impeller Shaft
S3	Wear Ring
S4	Impeller Nut
S5	Bearing Spacer
S6	Oil Seal Sleeve
S7	Plain Washer
S8	Shaft Nut

Ref No.	Description
S9	Mechanical Seal Kit (Includes S9, S17) (Also Includes B9 O-ring from Body Assembly)
S10	Cotter Pin, 1/8 x 1-3/4 in. (Prior to April 20, 1998)
S11	Oil Seal, 2-1/2 x 3-1/4 x 7/16 in.
S12	Oil Seal, 2 x 2-7/8 x 1/2 in.
S13	Flat Washer, 1 in.
S14	Square Key, 1/2 x 1/2 x 1-1/2 in.
S15	Ball Bearing, Double Row
S16	Ball Bearing, Single Row
S17	Cotter Pin, 5/32 x 1-3/4 in.

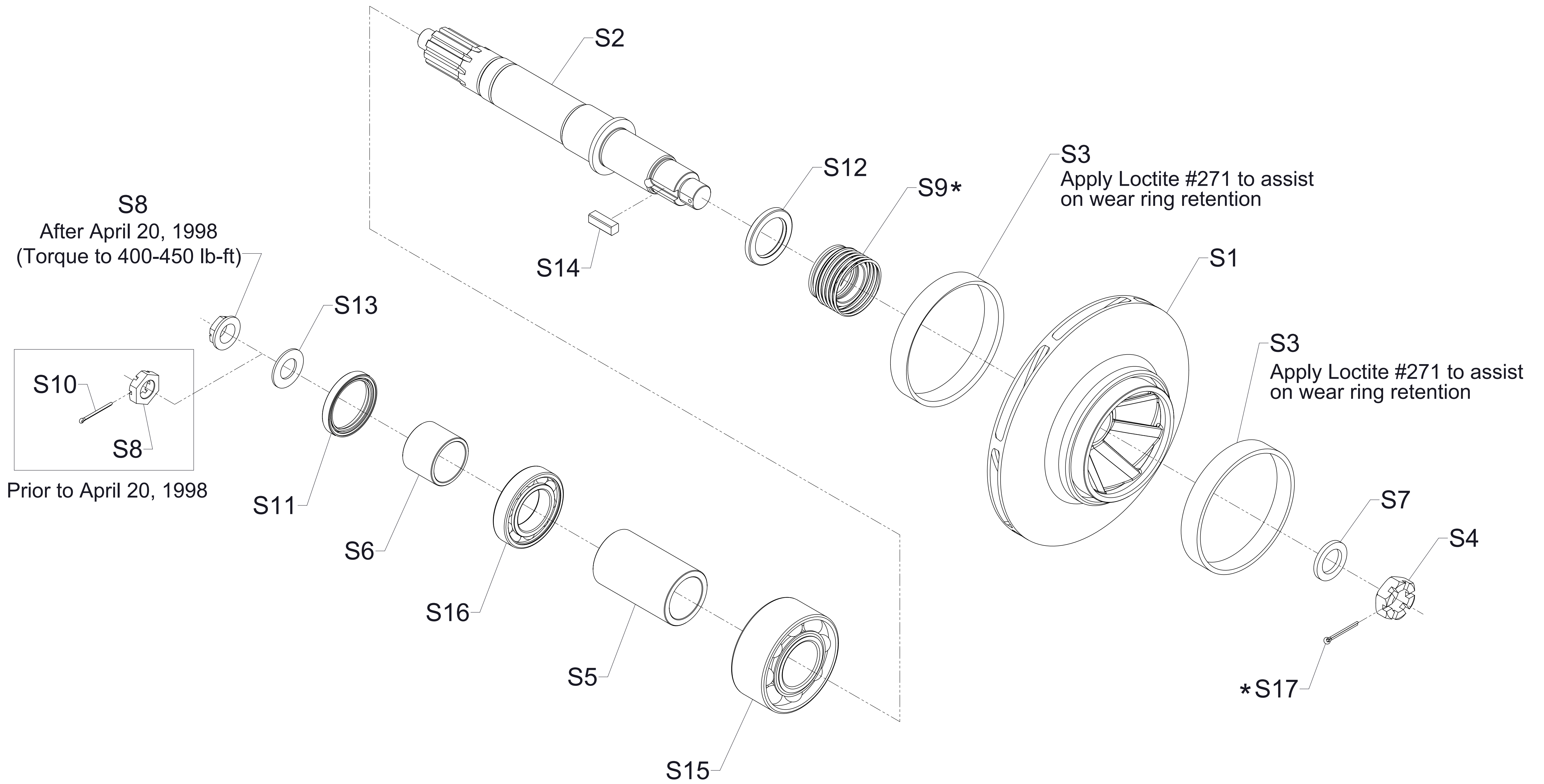

* Included in Mechanical Seal
repair Kit S9. Also includes
O-ring B9 from Body Assembly

Exploded View

Cross Section View

Ref No.	Description
S1	Impeller
S2	Impeller Shaft
S3	Wear Ring
S4	Impeller Nut
S5	Bearing Spacer
S6	Oil Seal Sleeve
S7	Plain Washer
S8	Shaft Nut

Ref No.	Description
S9	Mechanical Seal Kit (Includes S9, S17) (Also Includes B9 O-ring from Body Assembly)
S11	Oil Seal, 2-1/2 x 3-1/4 x 7/16 in.
S12	Oil Seal, 2 x 2-7/8 x 1/2 in.
S13	Flat Washer, 1 in.
S14	Square Key, 1/2 x 1/2 x 1-1/2 in.
S15	Ball Bearing, Double Row
S16	Ball Bearing, Single Row
S17	Cotter Pin, 5/32 x 1-3/4 in.

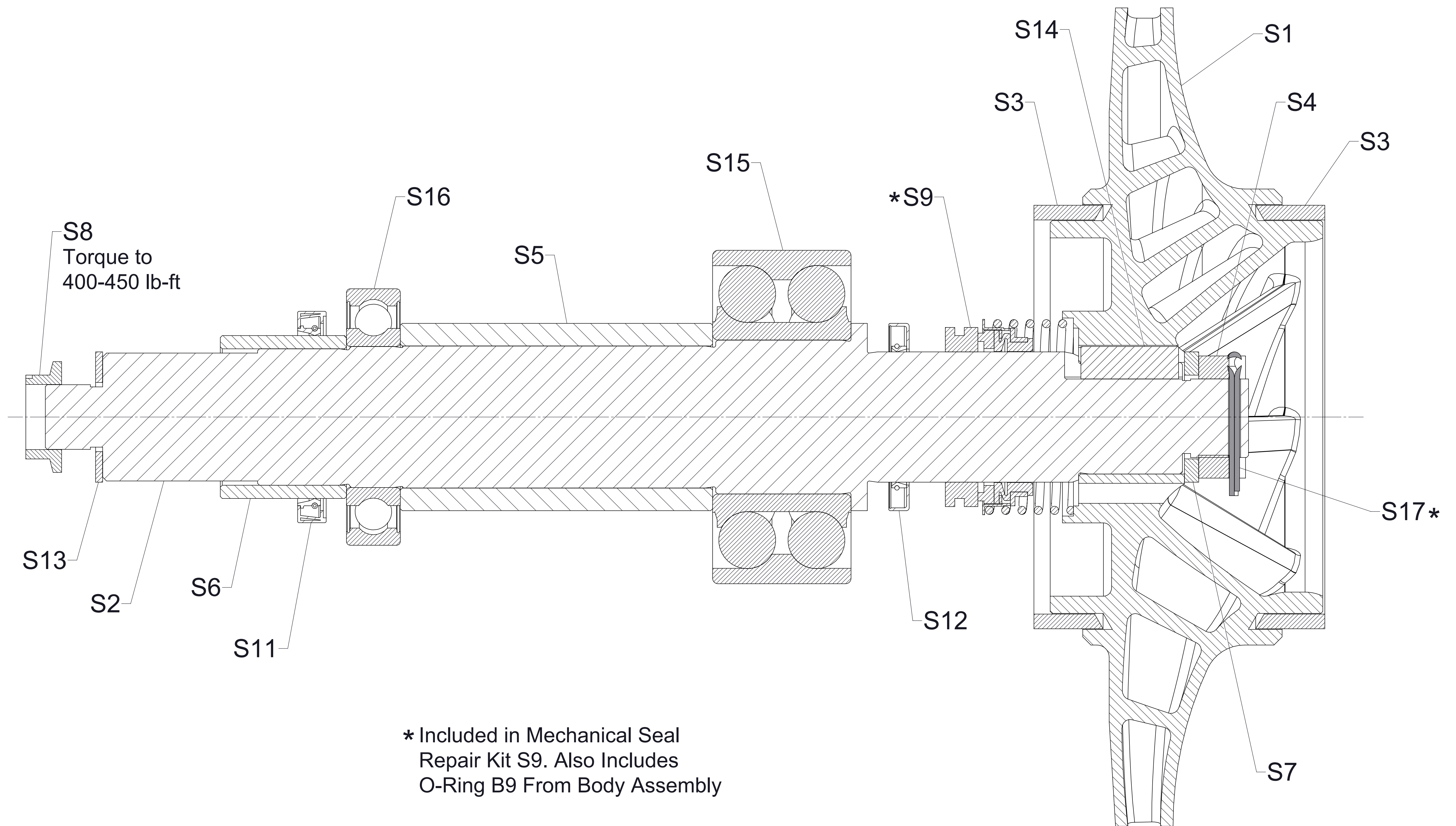

Cross Section View