



Document Number SPL82214	Issue Date 02/12/96	Rev. Date 10/2/15
------------------------------------	-------------------------------	-----------------------------

**Y Series Chain Drive Transmission for CMY/CMUY, CSY/CSUY Series Pumps
with Hydraulic Pump Mounting Provisions on Rear of Transmissions
Service Parts List**

REF NO.	DESCRIPTION
T1	Ball bearing, coupling shaft
T2	Bearing spacer, coupling shaft
T3	Ball bearing, drive shaft pilot
T4	Shift collar
T5	Drive sprocket
T6	Needle bearing
T7	Drive shaft spacer
T8	Hex hd screw w/thread sealant, 3/8-16 x 1-1/4 in.
T9	Lock washer, 3/8 in.
T10	Drive gear, tachometer
T11	Drive shaft housing
T12	Cotter pin, SS, 1/8 x 1-3/4 in.
T13	Drive shaft
T14	Oil seal sleeve
T15	Ball bearing, drive shaft
T17	Drive shaft housing gasket
T18	Drive chain
T19	Oil seal
T23	Oil seal housing
T24	Oil seal housing gasket
T25	Ball bearing, driven shaft
T26	Driven sprocket
T27	Breather

REF NO.	DESCRIPTION
T28	Chain case assembly (Supplied as assembly only consisting of mid-section and bottom section)
T29	Bearing spacer, driven shaft
T30	Shim, bearing housing, 0.005 (blue) and 0.010 (brown) in. thick
T32	Bearing lock washer
T33	Bearing lock nut
T37	Pivot pin
T38	Locking arm assembly
T39	O-ring
T40	Shifter shoe
T41	Shim, coupling shaft housing, 0.005 (blue), 0.007 (natural), and 0.010 (brown) in. thick
T42	Coupling shaft housing
T43	Shaft nut
T44	Coupling shaft
T45	Oil seal
T46	Shift shaft
T47	Sector gear
T48	Gear sector spacer
T49	O-ring
T50	Shift shaft bushing
T51	Spirol pin, SS, 5/16 x 1-3/8 in.

Y Series Chain Drive Transmission for CMY/CMUY, CSY/CSUY Series Pumps with Hydraulic Pump Mounting Provisions on Rear of Transmissions

REF NO.	DESCRIPTION
T53	Lock washer, 1/2 in.
T54	Spirol pin, heavy duty, 3/8 x 1-3/4 in. (used prior to 9/25/98 on pneumatic shift, prior to 12/20/02 on manual or electric shift)
T55	Shift cover
T56	Shift cover gasket
T57	Street elbow, 90°, 1/2 in.
T58	Magnetic drain plug, 3/4 in.
T59	Spring housing, shift arm
T60	Spirol pin, SS, 1/4 x 1-1/4 in.
T61	Shift arm spring
T62	Shift arm
T64	Hose, oil pump to spray tube
T65	Chain case cap
T66	Straight adapter union, 1/2 in.
T67	Hose, sump to oil pump
T68	Hex hd screw, 1/2-20 x 2-1/4 or 4-1/4 in.
T69	Hex nut, 1/2-20
T70	Hex hd screw, 1/2-13 x 1-1/2 in. or 3-1/2 in.
T72	Hex hd screw, 1/2-13 x 1 in., Grade 5 (with thread sealant)
T73	Sq hd pipe plug, 3/4 in.
T75	Shifter shoe (included with fork T80) Available individually for repairs

REF NO.	DESCRIPTION
T76	Shifter shoe stud (included with fork T80) Available individually for repairs
T80	Shift fork (supplied with shifter shoe T75 and shifter shoe studs T76)
T83	Pin set, connecting (chain repairs)
T85	Drain pipe
T86	Adjusting screw
T87	Adjusting screw retainer
T88	Driven gear bushing, tachometer
T89	Driven gear, tachometer
T90	Driven gear sleeve, tachometer
T93	Hex hd screw, 1/2-20 x 1-3/4 in.
T94	Washer, plain, 1-1/4 in.
T95	Bearing spacer, driven shaft
T98	Sq hd pipe plug, 1/2 in.
T99	Spacer, cap
T100	Spacer, cap (YC only)
T101	Nipple, pipe, 1/2 x 2-1/2 in.
T102	Tee, pipe, 1/2 in.
T103	Pin, dowel, 1/2 x 1-1/2 in. (YB) or 3 in. (YC)
T104	Spacer, tachometer gear

Y Series Chain Drive Transmission for CMY/CMUY, CSY/CSUY Series Pumps with Hydraulic Pump Mounting Provisions on Rear of Transmissions

REF NO.	DESCRIPTION
T105	Ring, retaining
T108	Spirol pin, heavy duty, SS, 1/16 x 1/4 in. (chain repairs)
T109	Stud, 1/2-13 x 1/2-20 (YC only), 4-1/4
T110	Stud, 1/2-20 x 1/2-20 (YC only), 4-3/4
T112	Lower shift shaft bushing
T131	Pin, dowel, 3/8 x 1 in. (part of T28)
T132	Oil strainer
T133	Hex hd screw, 3/8-16 x 1 in.
T134	Sight plug
T135	Shaft, driven
T136	Square key, 5/16 x 2-5/16 in.
T139	Serial plate
T140	Rd hd drive screw, No. 6 x 1/4 in.
T141	Gasket and shim kit, consists of: T17, T24, T30, T41, T43, T56, T94 and T96
T159	Coupling pipe, 1/2 NPT
T169	Hydraulic Pump adapter
T170	Retaining ring
T171	Street elbow, 45°, 1/2 in.
T172	Adapter union, 90°, 1/2 in.
T173	Actuating shift lever

REF NO.	DESCRIPTION
T174	Hex hd screw, 1/2-13 x 1-3/4 in.
T180	Magnetic pick-up
T181	O-ring, 5/8 x 3/4 in.
T182	O-ring, 4-3/4 x 5 in.
T186	Hex hd screw, 1/2-13 x 1-1/4 in., Grade 5 (with thread sealant)
T187	Oil seal, 3-1/2 x 4-3/8 in.
T188	Pipe nipple, 1/2 x 1-1/8 in.
T189	Oil seal, 1-3/8 x 2 in.
T190	Bearing sleeve
T191	Nipple, pipe, 1/2 x 4-1/2 in.
T192	Elbow, Female, 90°, 1/2 NPT
T230	Drive shaft spacer
T231	Oil seal, 2-1/2 in. x 3-1/2 in.
T237	Shoulder screw, 3/8 x 1-3/4 in. (after 9/25/98 on pneumatic shift, after 12/20/02 on manual or electric shift)
T238	Lock nut, 5/16-18 in. (after 9/25/98 on pneumatic shift, after 12/20/02 on manual or electric shift)
T239	Spacer, tachometer
T240	Hex hd screw, 1/2-20 x 2-1/2 in.
T241	Hex hd screw with thread sealant, 3/8-16 x 1-1/2 in.

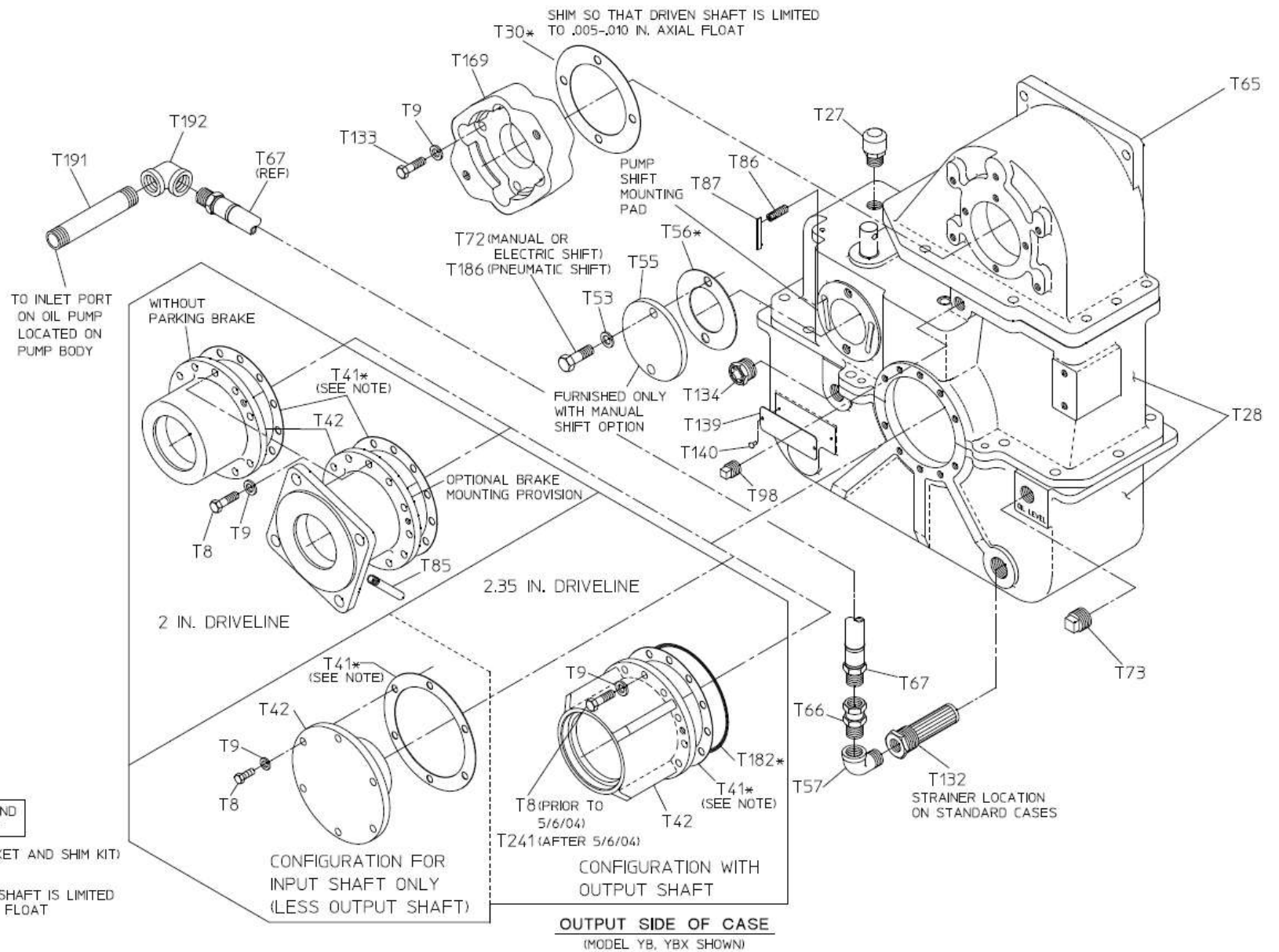

*PART OF T141 (GASKET AND SHIM KIT)
T41*
SHIM SO THAT DRIVE SHAFT IS LIMITED TO .005-.010 AXIAL FLOAT

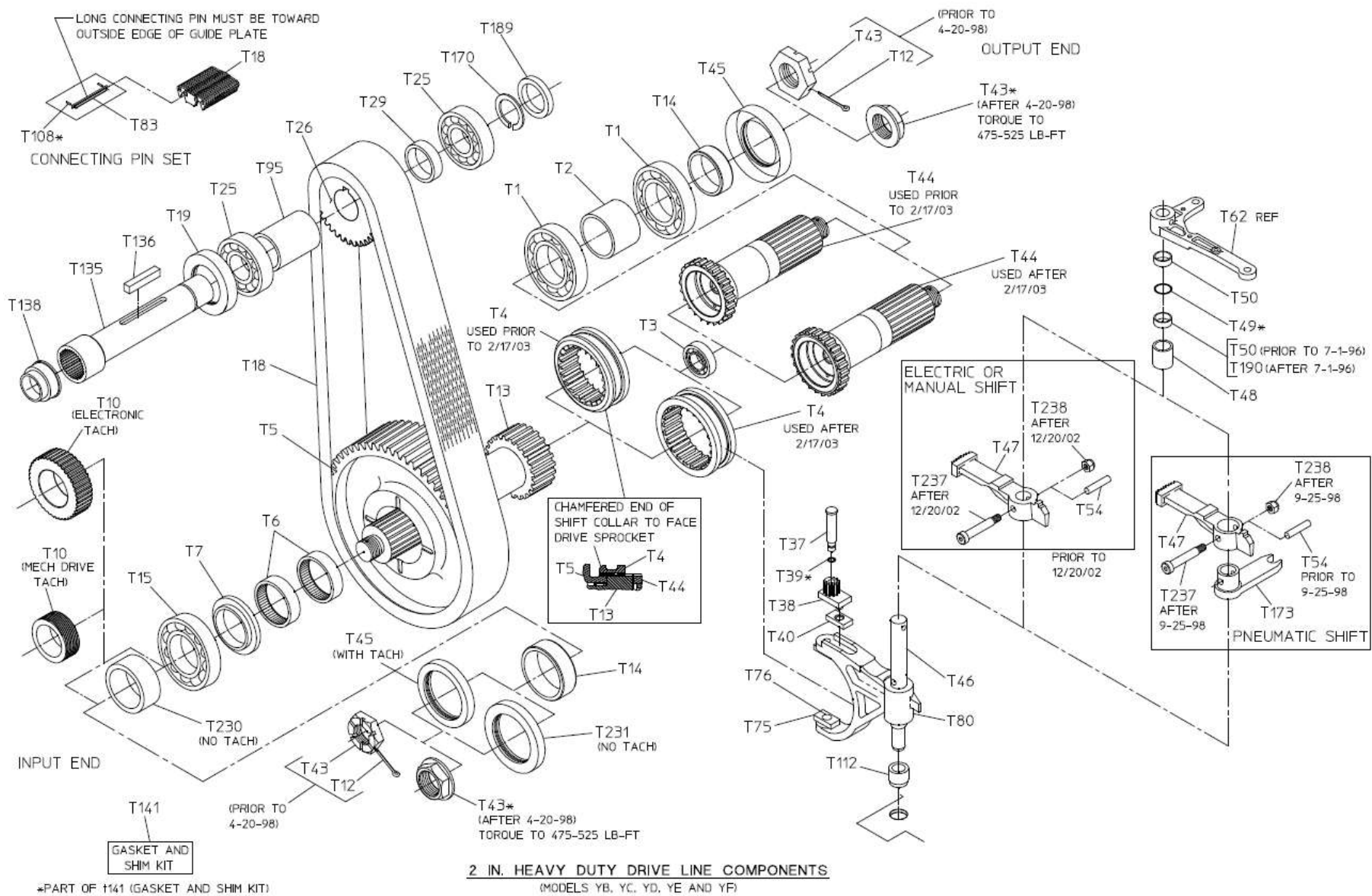

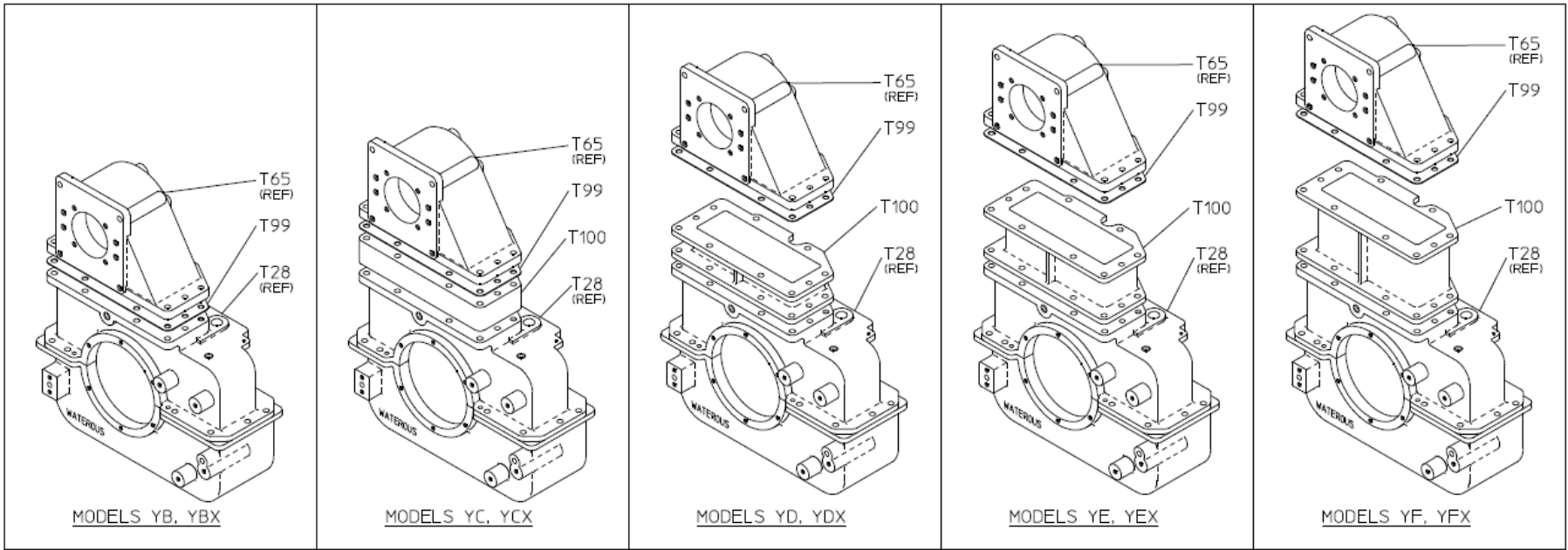

RATIOS	MODELS YB, YBX	MODELS YC, YCX		MODELS YD, YDX		MODELS YE, YEX		MODELS YF, YFX	
	T99	T99	T100	T99	T100	T99	T100	T99	T100
1.14	2	6	1	4	1	3	1	2	1
1.27	0	0	1	3	1	2	1	1	1
1.41	0	3	1	3	1	2	1	1	1
1.48	4	5	1	3	1	1	1	1	1
1.58	0	2	1	2	1	1	1	0	1
1.69	4	0	1	1	1	4	1	4	1
1.79	2	1	1	1	1	3	1	2	1
1.88	2	0	1	1	1	3	1	2	1
1.97	2	1	1	2	1	2	1	3	1
2.03	0	2	1	2	1	1	1	2	1
2.27	0	3	1	0	1	0	1	0	1
2.46	3	3	1	1	1	3	1	3	1
2.73	3	1	1	3	1	2	1	2	1

SPACERS BETWEEN CAP (T65) AND CASE (T28)
(SEE FOLLOWING PAGES FOR HARDWARE DETAILS)

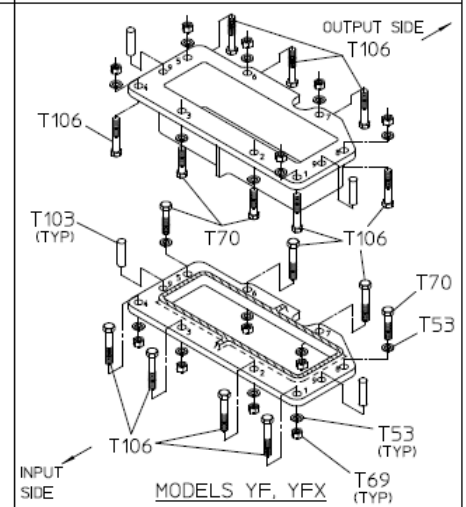
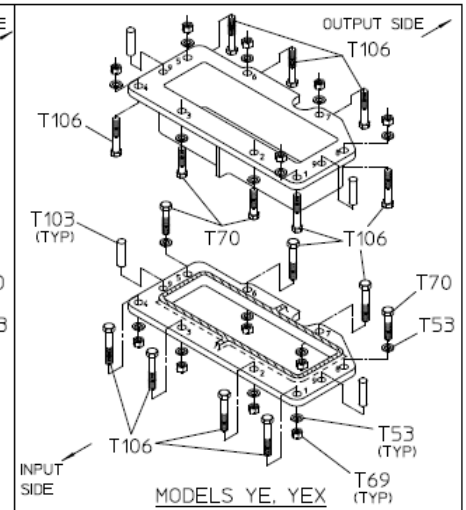
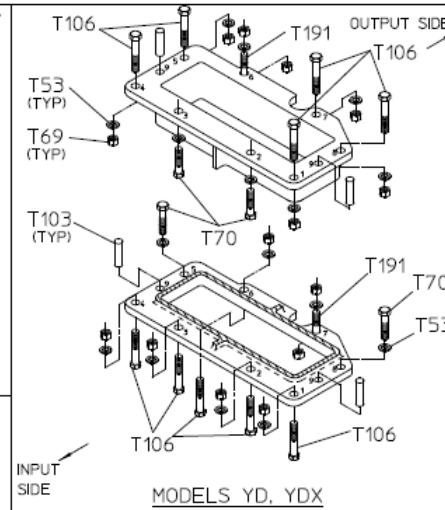
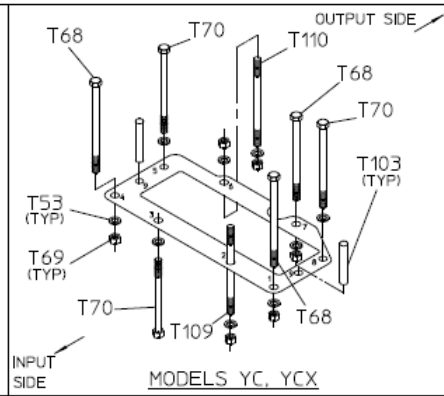
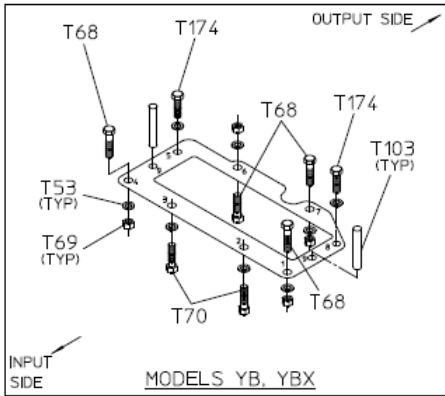

REF NO.	TYPE	THREAD	LENGTH (MODEL)				
			YB, YBX	YC, YCX	YD, YDX	YE, YEX	YF, YFX
T53	LOCKWASHER	1/2	---	---	---	---	---
T68	HEX HD SCREW	1/2-20	2-1/4	4-1/4	---	---	---
T69	HEX NUT	1/2-20	---	---	---	---	---
T70	HEX HD SCREW	1/2-13	1-1/2	3-1/2	1-1/2	1-1/2	1-1/2
T103	DOWEL PIN, 1/2	---	1-1/2	3	1-1/2	1-1/2	1-1/2
T106	HEX HD SCREW	1/2-20	---	---	2	---	---
T109	STUD	1/2-13 x 1/2-20	---	4-1/4	5-1/4 OR 5-3/4	---	---
T110	STUD	1/2-20 x 1/2-20	---	4-3/4	6 OR 6-1/4	---	---
T174	HEX HD SCREW	1/2-13	1-3/4	---	---	---	---
T191	STUD	1/2-20 x 1/2-20	---	---	2-3/4	---	---

HOLE NO.	MODELS YB, YBX ALL RATIOS	MODELS YC, YCX ALL RATIOS	MODELS YD, YDX		MODELS YE, YEX		MODELS YF, YFX	
			ALL RATIOS		ALL RATIOS		ALL RATIOS	
			UPPER	LOWER	UPPER	LOWER	UPPER	LOWER
1	T68	T68	T106	T106	T106	T106	T106	T106
2	T70	T109	T70	T106	T70	T106	T70	T106
3	T70	T70	T70	T106	T70	T106	T70	T106
4	T68	T68	T106	T106	T106	T106	T106	T106
5	T174	T70	T106	T70	T106	T70	T106	T70
6	T68	T110	T191	T106	T106	T106	T106	T106
7	T68	T68	T106	T191	T106	T106	T106	T106
8	T174	T70	T106	T70	T106	T70	T106	T70
9 (2) LOCATIONS	T103	T103	T103	T103	T103	T103	T103	T103

FLANGE HARDWARE BETWEEN CAP (T65) AND CASE (T28)

