

Issued: 02/14/97

Revised: 11/02/07

**WATEROUS**

WATEROUS

SOUTH ST. PAUL, MINNESOTA

## 4 Inch Indicating Relief Valve

REF NO.	DESCRIPTION	REF NO.	DESCRIPTION
V4	Spring	V30	Wiring assembly
V5	Main valve	V31	Wiring assembly
V6	Cover gasket	V32	Indicating light wire
V7	Cover	V35	Wiring assembly
V8	Body	V36	Green indicating light
V9	Hex hd screw, 3/8-16 x 1"	V37	Amber indicating light
V10	O-ring	V38	Replacement bulb (12 volt - light no. 1891) (24 volt - light no. 313)
V11	Pipe plug, 1/4" NPT	V39	Actuator switch
V12	Seat	V40	Straight sealing grip
V13	Sleeve	V52	O-ring
V21	CH actuating rod	V59	Complete replacement valve without wiring assembly
V22	Rod spring	V60	Repair kit (consists of V6, V10, V25, V27 and V52)
V24	Switch bracket	V61	Retaining ring
V25	O-ring	V62	Tube connector, 3/8" x 1/4"
V26	Copper washer, 3/8"		
V27	Groove pin		

**PLEASE NOTE**

**WHEN ORDERING PARTS PLEASE SUPPLY PUMP SERIAL NUMBER**

SPL82260

PAGE 1 OF 4

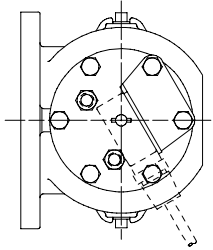

LEFT FACING AND LEFT MOUNTING  
DISCHARGE ASSEMBLIES

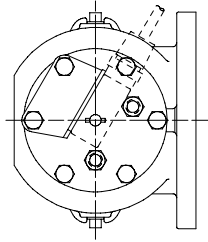

RIGHT FACING AND RIGHT MOUNTING  
DISCHARGE ASSEMBLIES

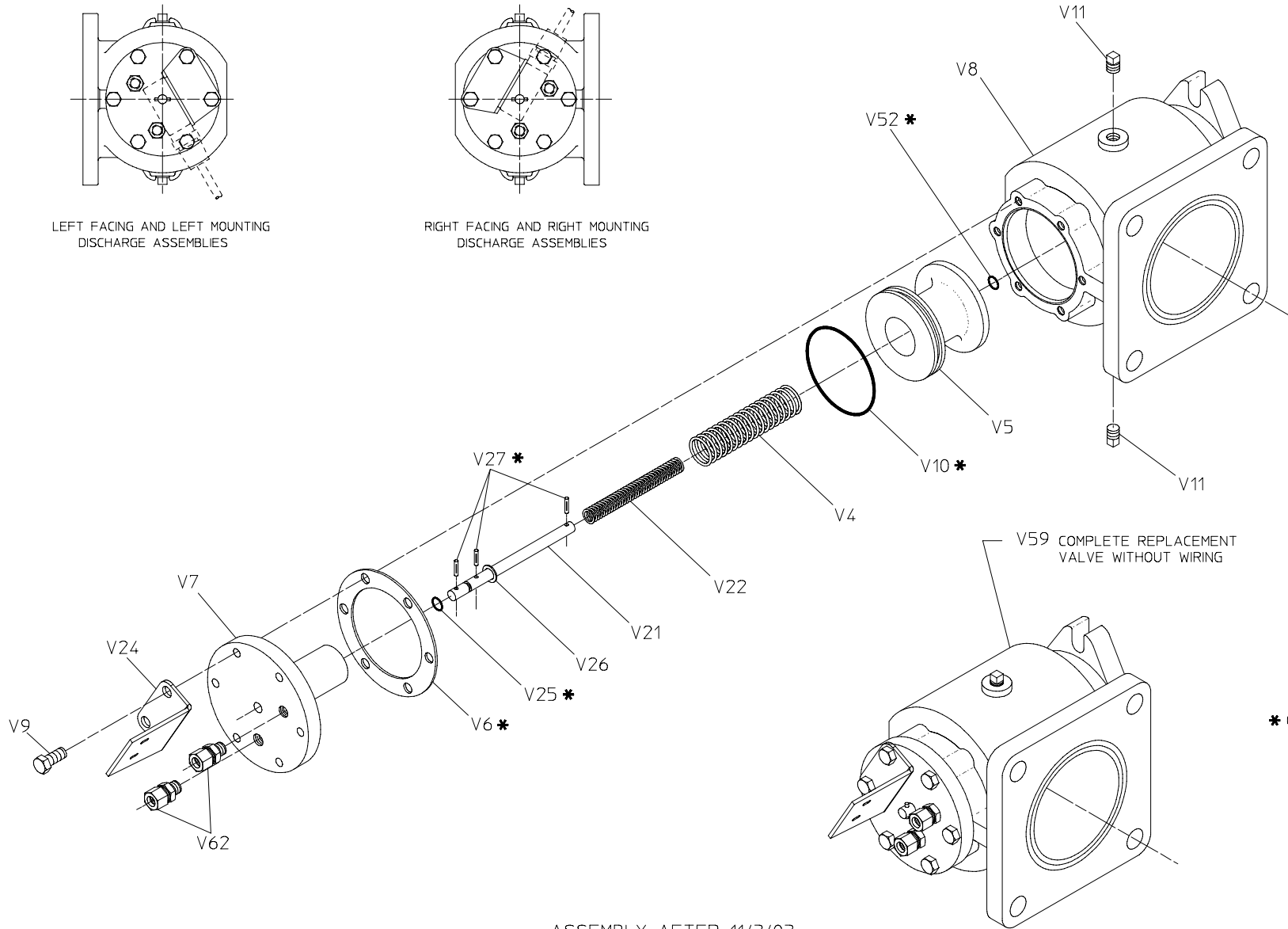

ASSEMBLY AFTER 11/3/03

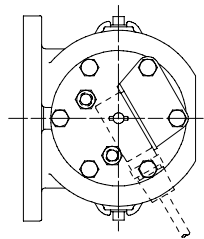

LEFT FACING AND LEFT MOUNTING  
DISCHARGE ASSEMBLIES  
82260-1, -3 (12V), 82260-9,  
-11 (24V) (WITH WIRING POINTING  
DOWN) 82260-5 & -7 (WITHOUT WIRING)

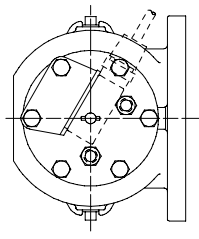

RIGHT FACING AND RIGHT MOUNTING  
DISCHARGE ASSEMBLIES  
82260-2, -4 (12V), 82260-10, -12 (24V)  
(WITH WIRING POINTING UP) 82260-6 & -8  
WITHOUT WIRING)

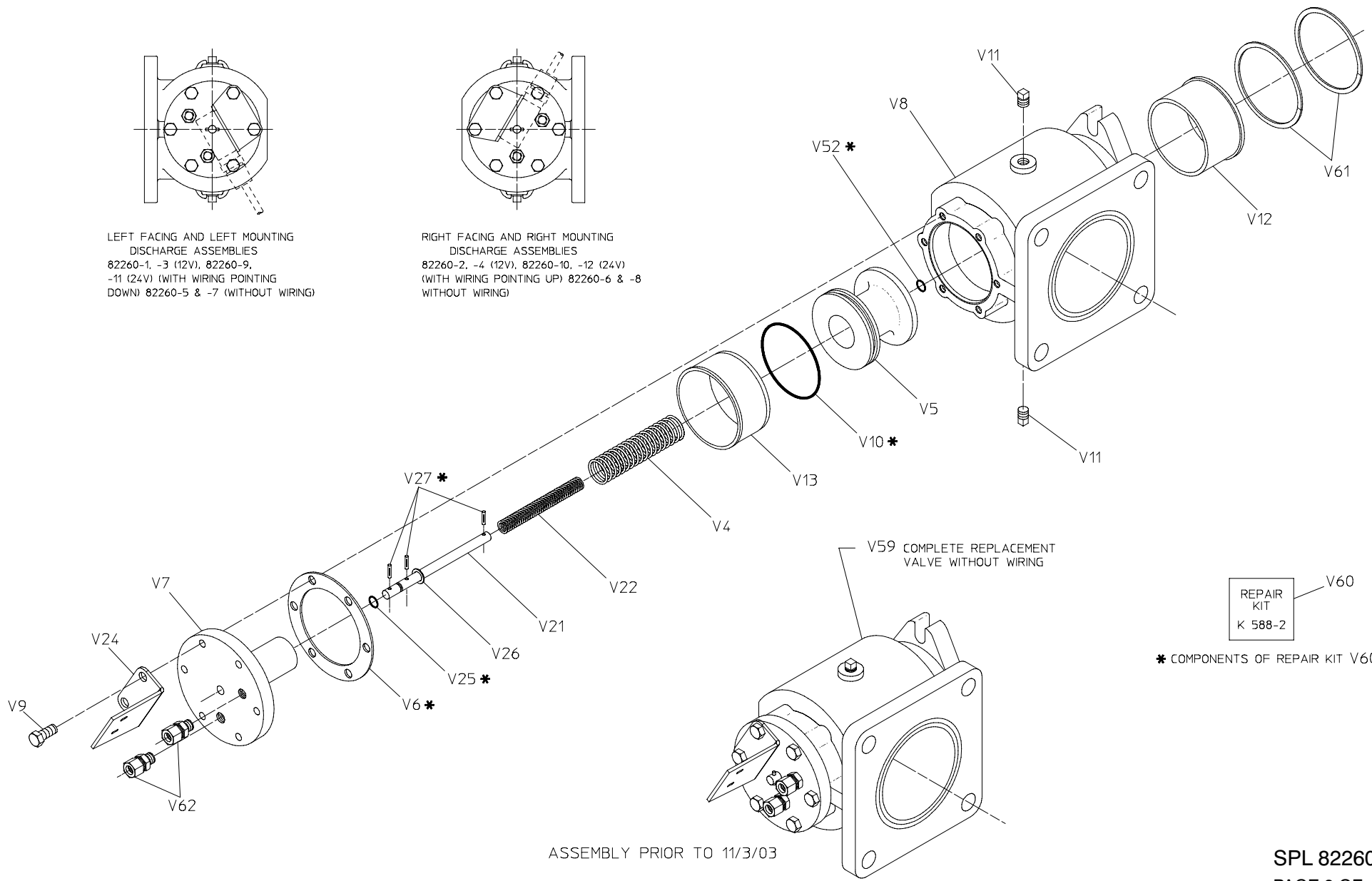

REPAIR  
KIT  
K 588-2

\* COMPONENTS OF REPAIR KIT V60

ASSEMBLY PRIOR TO 11/3/03

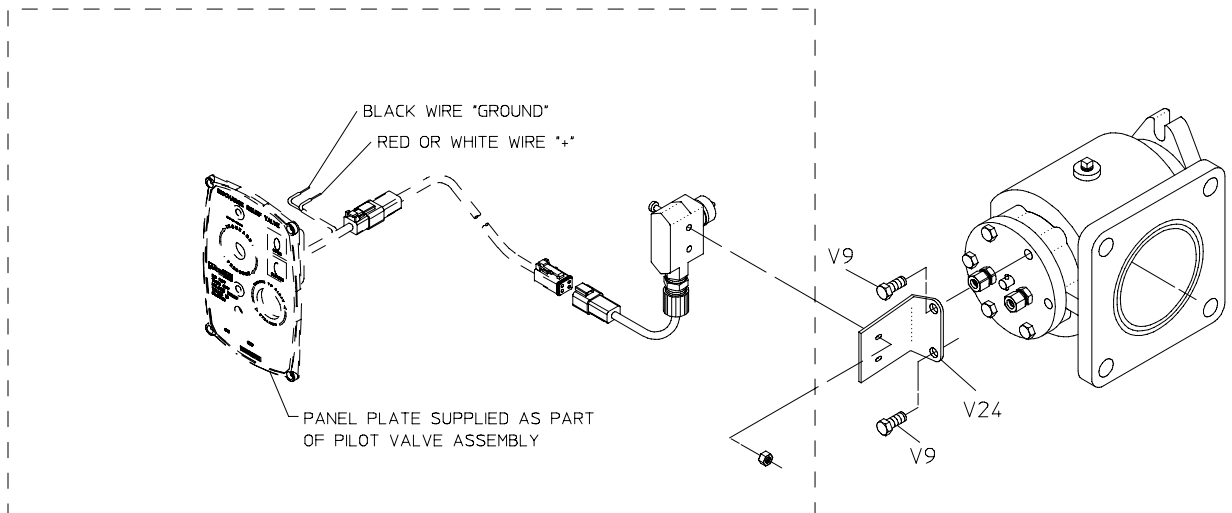

V30  
WIRING ASSEMBLY  
AFTER 4/21/06

NOTE: ADJUST POSITION OF SWITCH SO THAT INSERTION OF A .015 IN. FEELER GAGE WILL LIGHT AMBER INDICATOR, BUT INSERTION OF A .010 IN. FEELER GAGE WILL NOT.

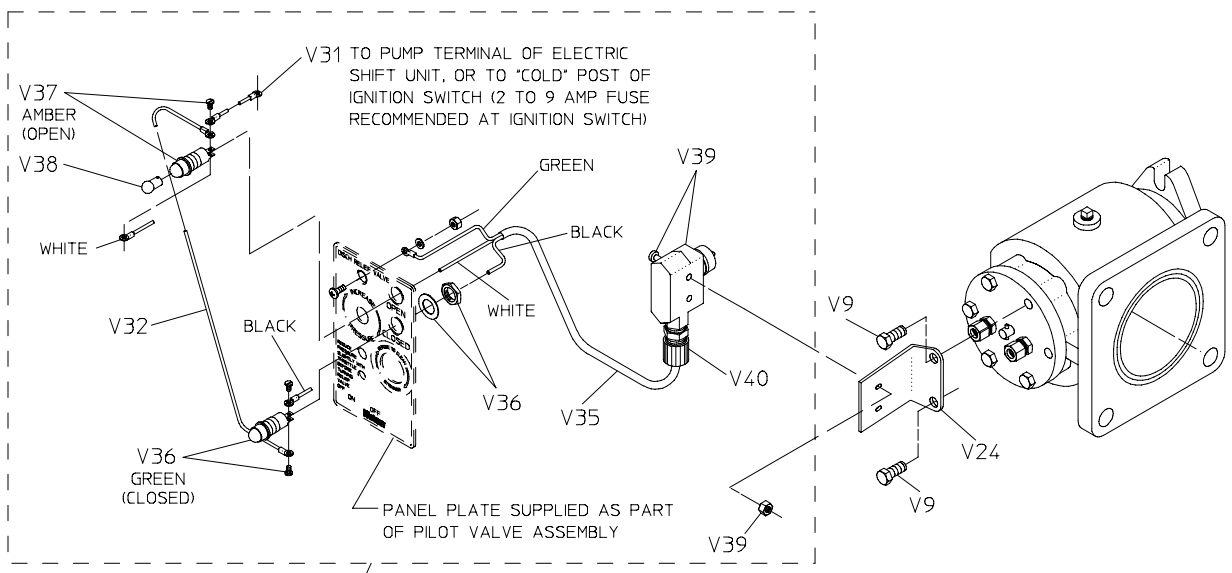
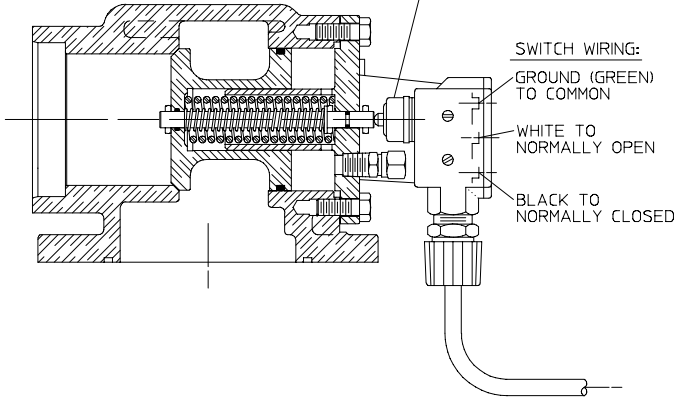

V30  
WIRING ASSEMBLY  
PRIOR TO 4/21/06

**WIRING DETAILS**