

Issued: 04/27/98

Revised: 12/01/04

**W A T E R O U S**

WATEROUS COMPANY

SOUTH ST. PAUL, MINNESOTA

## Y SERIES TRANSMISSION WITH AIR DRIVE CLUTCH MOUNTING PROVISION ON REAR

REF NO.	DESCRIPTION	REF NO.	DESCRIPTION
T1	Ball bearing	T28	Chain case assembly (Supplied as assembly only consisting of mid section and bottom section)
T2	Spacer, coupling shaft	T29	Bearing spacer, driven shaft
T3	Ball bearing, drive shaft pilot	T30	Shim, bearing housing, 0.005 (blue) and 0.010 (brown) in. thick
T4	Shift collar	T37	Pivot pin, 5/8 x 2-3/4 in.
T5	Drive sprocket	T38	Locking arm assembly
T6	Needle bearing	T39	O-ring, 1/4 x 3/8 in.
T7	Thrust washer	T40	Shifter shoe
T8	Hex hd screw, 3/8-16 x 1-1/4 in.	T41	Shim, coupling shaft housing, 0.005 (blue), 0.007 (natural), and 0.010 (brown) in. thick.
T9	Lock washer, 3/8 in.	T42	Coupling shaft housing
T10	Drive gear or pulse generator, tachometer	T43	Shaft nut
T11	Drive shaft housing subassembly	T44	Coupling shaft
T12	Cotter pin, SS, 1/8 x 1-3/4 in.	T45	Oil seal, 2-3/4 x 3-1/2 in.
T13	Drive shaft	T46	Shift shaft
T14	Oil seal sleeve	T47	Sector gear
T15	Ball bearing, drive shaft	T48	Gear sector spacer
T17	Drive shaft housing gasket	T49	O-ring, 7/8 x 1 in.
T18	Drive chain	T50	Bearing sleeve
T19	Oil seal, 1-7/8 x 2-3/4 in.	T51	Spirol pin, SS, 5/16 x 1-3/8 in.
T23	Oil seal housing	T53	Lock washer, 1/2 in.
T24	Oil seal housing gasket	T54	Spirol pin, heavy duty, 3/8 x 1-3/4 in. (prior to 9/25/98 on pneumatic shift, prior to 12/20/02 on manual or electric shift.)
T25	Ball bearing, driven shaft		
T26	Driven sprocket		
T27	Breather, 1/2 NPT		

**PLEASE NOTE**

**WHEN ORDERING PARTS PLEASE SUPPLY PUMP SERIAL NUMBER**

SPL82322

PAGE 1 OF 9

## Y SERIES TRANSMISSION WITH AIR DRIVE CLUTCH MOUNTING PROVISION ON REAR

REF NO.	DESCRIPTION	REF NO.	DESCRIPTION
T55	Shift cover	T85	Drain pipe
T56	Shift cover gasket	T86	Adjusting screw
T57	Street elbow, 90°, 1/2 in. NPT	T87	Adjusting screw retainer
T58	Magnetic drain plug, 3/4 in. NPT	T88	Driven gear bushing, tachometer
T59	Spring housing, shift arm	T89	Driven gear, tachometer
T60	Spirol pin, SS, 1/4 x 1-1/4 in.	T90	Driven gear sleeve, tachometer
T61	Shift arm spring	T93	Hex hd screw, 1/2-20 x 1-3/4 in.
T62	Shift arm	T94	Washer, plain, 1-1/4 in.
T64	Hose, oil pump to spray tube	T95	Bearing spacer, driven shaft
T65	Chain case cap	T98	Sq hd pipe plug, 1/2 in. NPT, steel
T66	Straight adapter union, 1/2 in.	T99	Spacer, cap
T67	Hose, sump to oil pump	T100	Spacer, cap (YC, YD, YE & YF)
T68	Hex hd screw, 1/2-20 x 2-1/4	T102	Tee, pipe, 1/2 in. NPT
T69	Hex nut, 1/2-20	T103	Pin, dowel, 1/2 x 1-1/2 in. (YB) or 3 in. (YC)
T70	Hex hd screw, 1/2-13 x 1-1/2 in.	T104	Spacer, tachometer gear
T72	Hex hd screw, 1/2-13 x 1 in., Grade 5 (with thread sealant)	T105	Ring, retaining (chain repairs)
T73	Sq hd pipe plug, 3/4 in. NPT	T108	Spirol pin, heavy duty, 1/16 x 1/4
T75	Shifter shoe (included with fork T80) Available individually for repairs	T109	Stud, 1/2-13 x 1/2-20 4-1/4 in. (YC only) or 5-1/4 in. (YD)
T76	Shifter shoe stud (included with fork T80) Available individually for repairs	T110	Stud, 1/2-20 x 1/2-20, 4-3/4 (YC only) or 6, 6-1/4 in (YD)
T80	Shift fork (supplied with shifter shoe T75 and shifter shoe studs T76)	T112	Lower shift shaft bushing
T83	Connecting set pin	T131	Pin, dowel, 3/8 x 1 in. (part of T28)
		T132	Oil strainer

## Y SERIES TRANSMISSION WITH AIR DRIVE CLUTCH MOUNTING PROVISION ON REAR

REF NO.	DESCRIPTION	REF NO.	DESCRIPTION
T133	Hex hd screw, 3/8-16 x 1 in.	T186	Hex hd screw, 1/2-13 x 1-1/4 in., Grade 5 (with thread sealant)
T134	Sight plug	T187	Oil seal, 3-1/2 x 4-3/8 in.
T135	Shaft, driven	T189	Seal, 1-3/8 x 2 in.
T136	Square key, 5/16 x 2-5/16 in.	T190	Bearing sleeve
T138	V-ring flinger (used prior to 8/26/93) Sealing boot (used after 8/26/93)	T191	Stud, 1/2-20 x 1/2-20 x 2-3/4 in. (YD)
T139	Serial plate	T192	Elbow, 1/2 in., 90°
T140	Rd hd drive screw, No. 6 x 1/4 in.	T230	Drive shaft spacer
T141	Gasket and shim kit, consists of: T56, T24, T41, T30, T96, T17, T94 & T43	T231	Oil seal, 2-1/2 in. x 3-1/2 in.
T170	Retaining ring	T232	Key, 5/16 in. x 1-3/4 in.
T171	45° street elbow, 1/2 in. NPT	T233	Oil seal housing
T173	Actuating shift lever	T237	Shoulder screw, 3/8 x 1-3/4 in. (after 9/25/98 on pneumatic shift, after 12/20/02 on manual or electric shift.)
T174	Hex hd screw, 1/2-13 x 1-3/4 in. (YB)	T238	Lock nut, 5/16-18 in. (after 9/25/98 on pneumatic shift, after 12/20/02 on manual or electric shift.)
T180	Magnetic pickup	T239	Spacer, tachometer
T181	O-ring, 5/8 x 3/4 in.	T240	Hex hd screw, 1/2-20 x 2-1/2 in.
T182	O-ring, 4-3/4 x 5 in.	T241	Hex hd screw with thread sealant, 3/8-16 x 1-1/2 in.
T183	Ball bearing, double row		

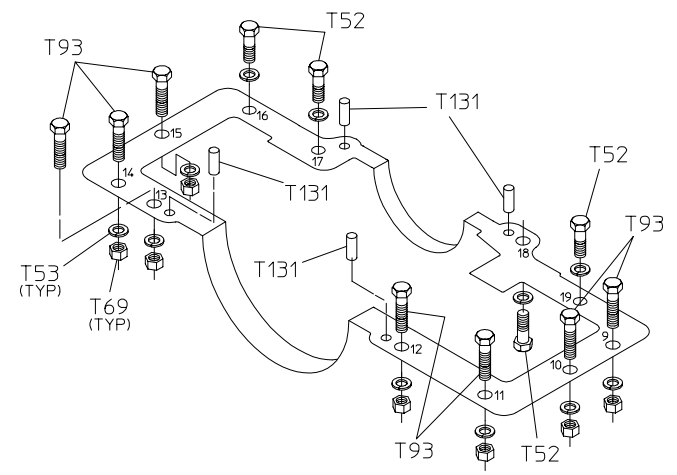
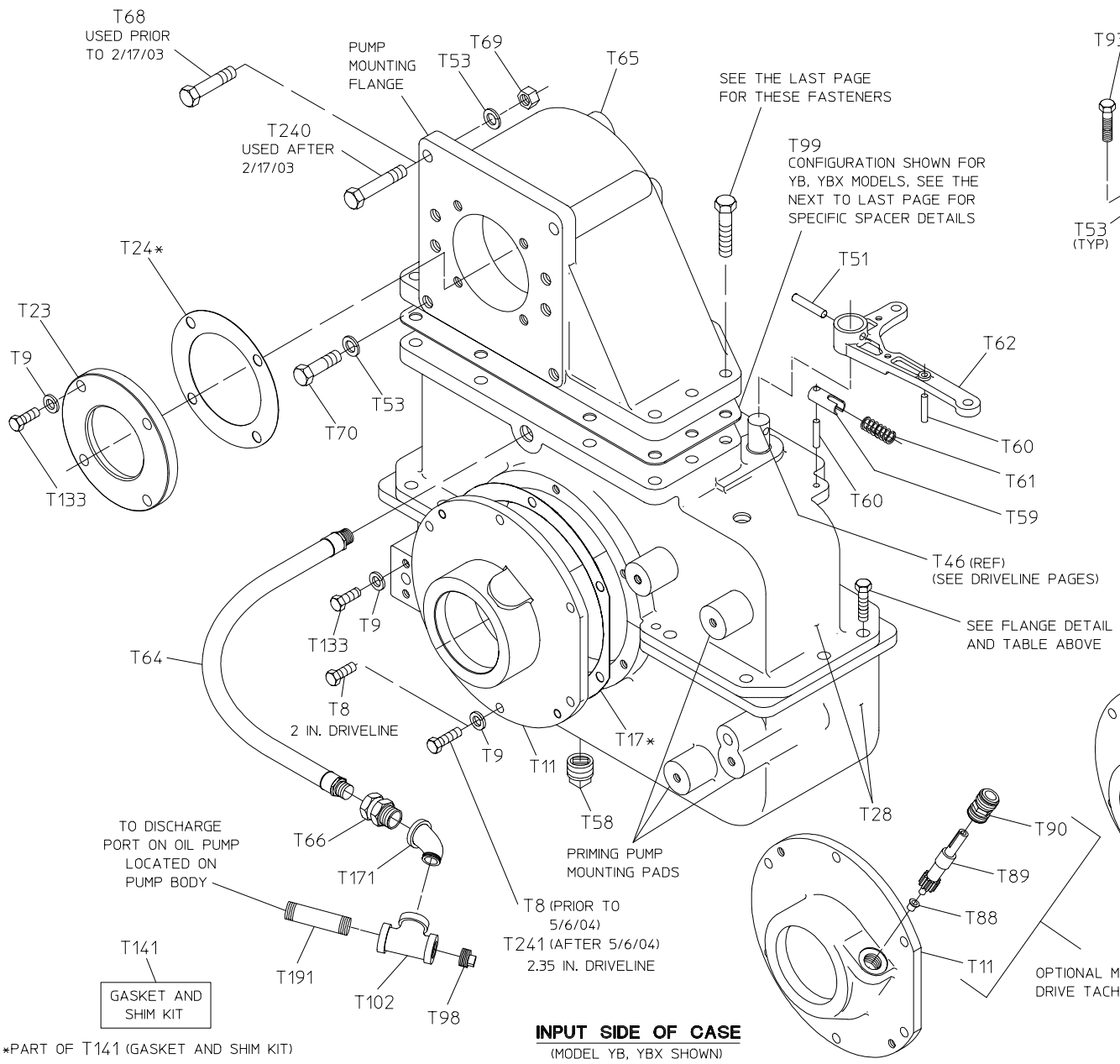

FASTENER TYPE AND LENGTH			
HOLE NO.	TYPE	THREAD	LENGTH
9 TO 15	HEX HD SCREW	1/2-20	1-3/4
16 TO 19	HEX HD SCREW	1/2-13	1-1/4

OPTIONAL CABLE  
PART NO. 63033,  
MAY NOT HAVE BEEN  
SUPPLIED BY WATEROUS

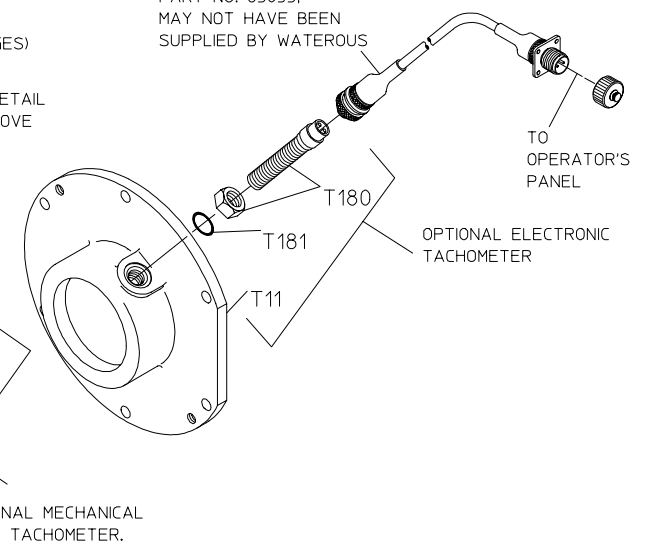

\*PART OF T141 (GASKET AND SHIM KIT)

**INPUT SIDE OF CASE**  
(MODEL YB, YBX SHOWN)

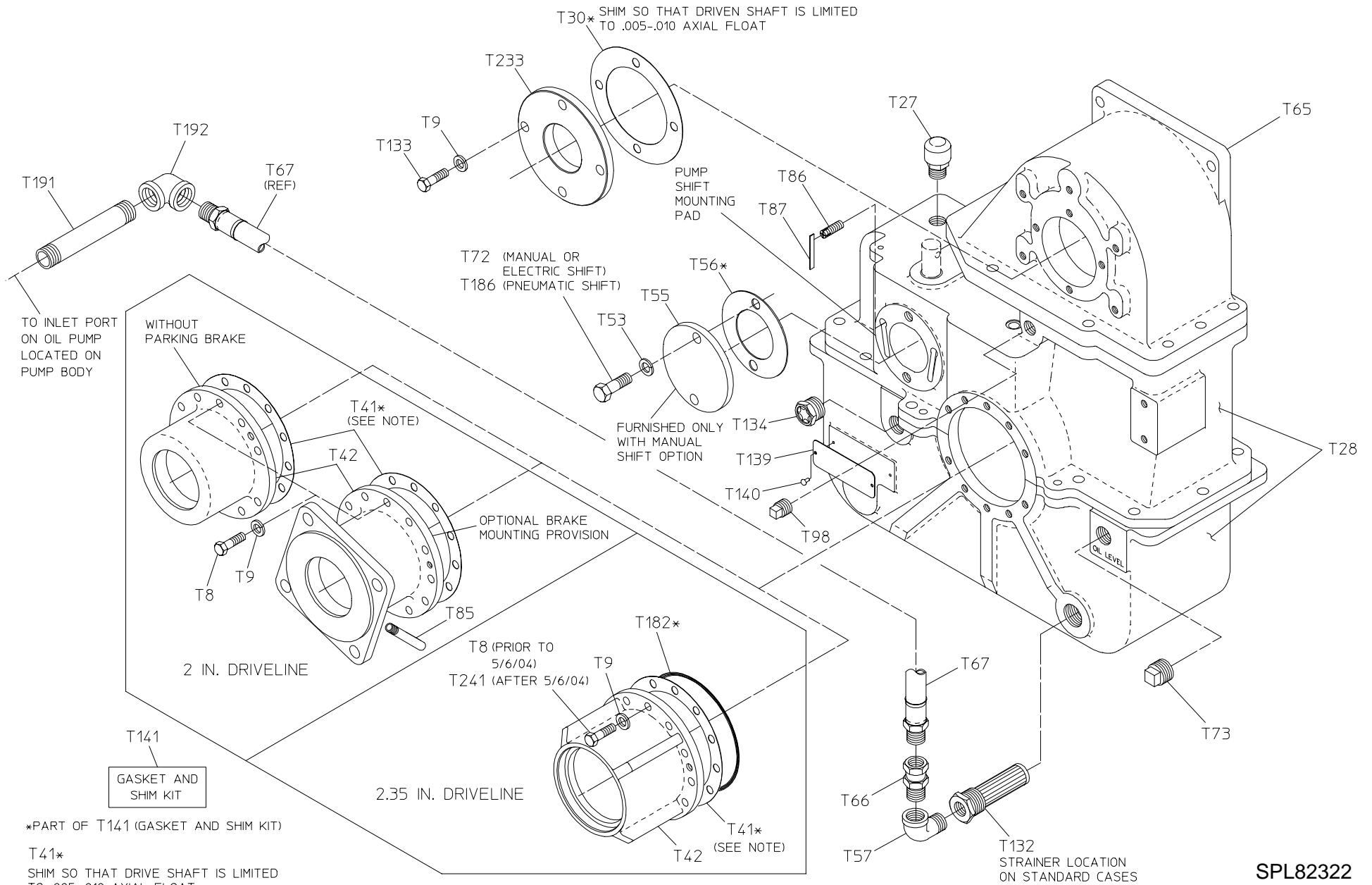

**OUTPUT SIDE OF CASE**  
(MODEL YB, YBX SHOWN)

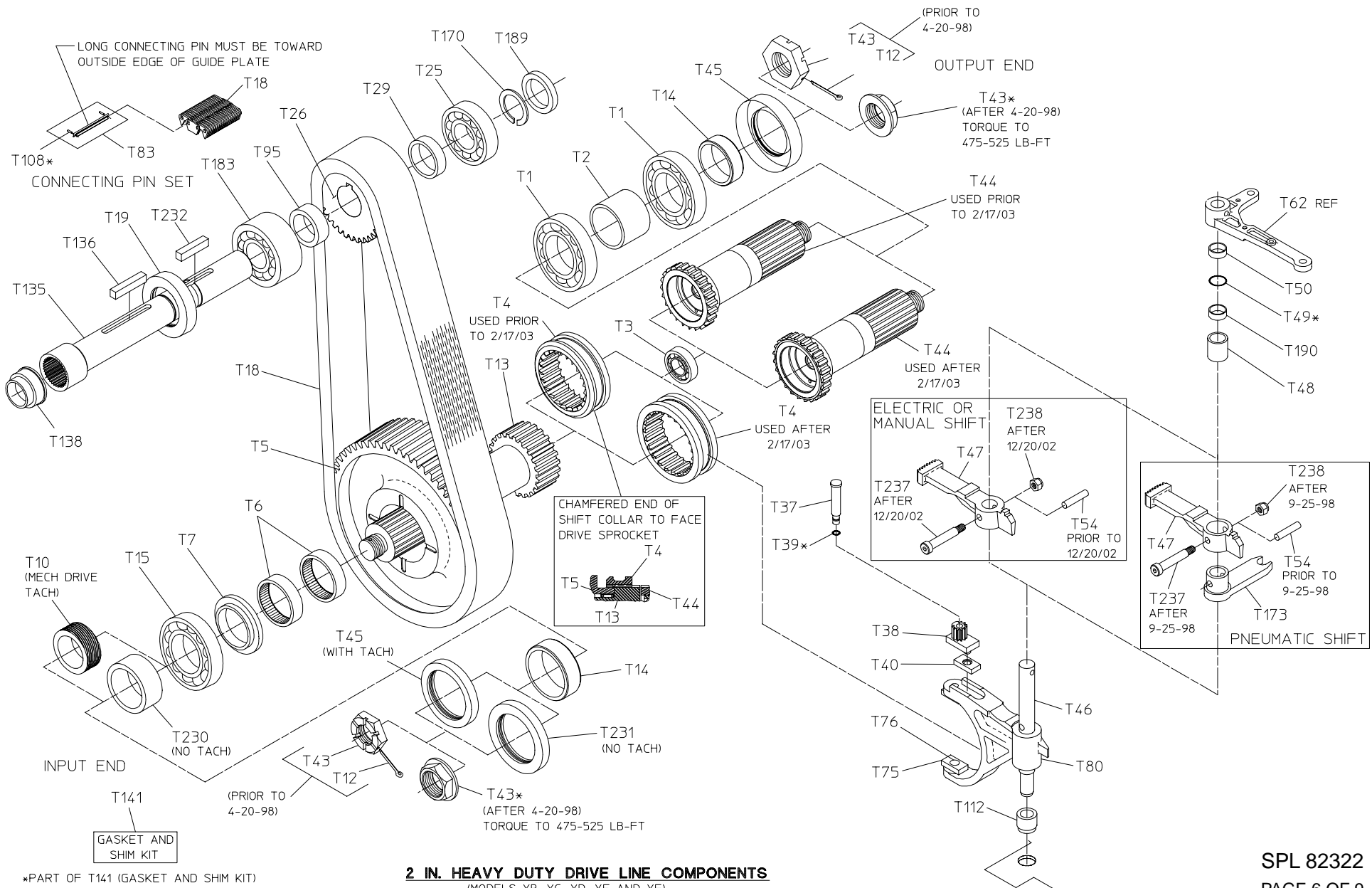

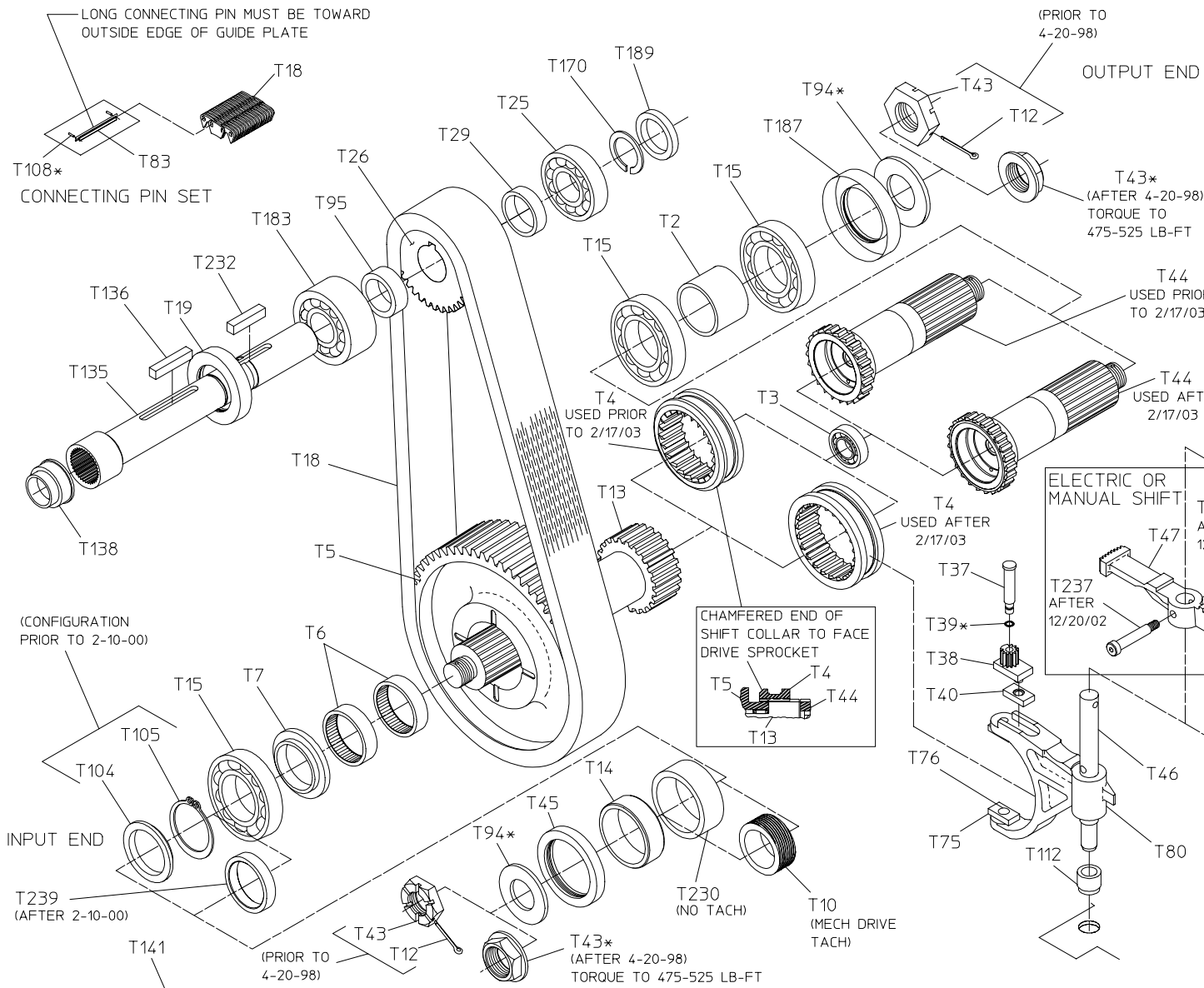

SERIES	YOKE PART NO.	CROSS & BRG KIT NO.
1710	V2837	V2839
1810	V2838	V2840

OPTIONAL END YOKE AND CROSS & BEARING KITS MAY NOT HAVE BEEN SUPPLIED BY WATEROUS

(CONFIGURATION PRIOR TO 2-10-00)

INPUT END

OUTPUT END

**2.35 IN. EXTRA HEAVY DUTY DRIVE LINE COMPONENTS**  
(MODELS YBX, YCX, YDX, YEX AND YFX)

\*PART OF T141 (GASKET AND SHIM KIT)

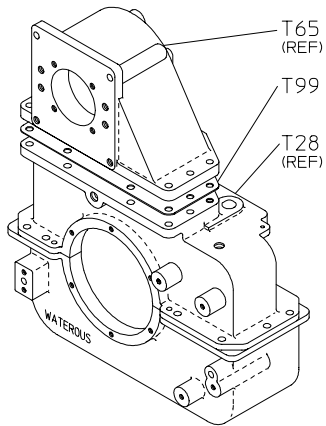

MODELS YB, YBX

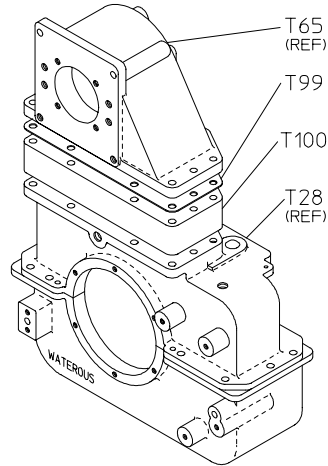

MODELS YC, YCX

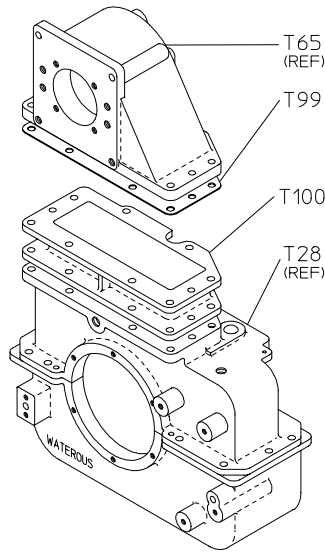

MODELS YD, YDX

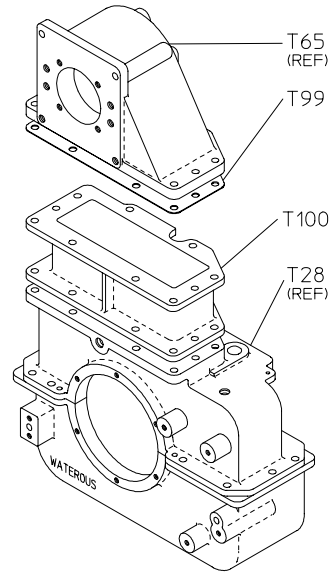

MODELS YE, YEX

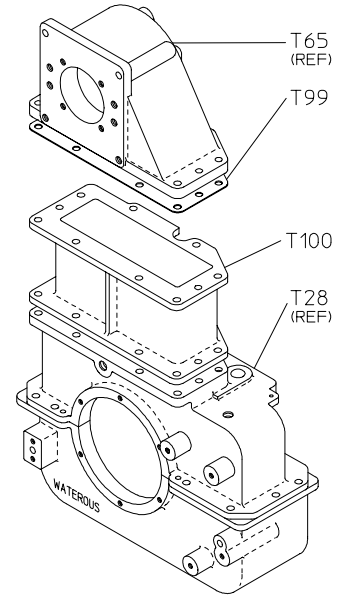

MODELS YF, YFX

RATIOS	MODELS YB, YBX		MODELS YC, YCX		MODELS YD, YDX		MODELS YE, YEX		MODELS YF, YFX	
	T99	T100	T99	T100	T99	T100	T99	T100	T99	T100
1.14	2	1	6	1	4	1	3	1	2	1
1.27	0	1	0	1	3	1	2	1	1	1
1.41	0	1	3	1	3	1	2	1	1	1
1.48	4	1	5	1	5	1	1	1	1	1
1.58	0	1	2	1	2	1	1	1	0	1
1.69	4	1	0	1	1	1	4	1	4	1
1.79	2	1	1	1	1	1	3	1	2	1
1.88	2	1	0	1	1	1	3	1	2	1
1.97	2	1	1	1	2	1	2	1	3	1
2.03	0	1	2	1	2	1	1	1	2	1
2.27	0	1	3	1	0	1	0	1	0	1
2.46	3	1	3	1	1	1	3	1	3	1
2.73	3	1	1	1	3	1	2	1	2	1

SPACERS BETWEEN CAP (T65) AND CASE (T28)  
(SEE FOLLOWING PAGES FOR HARDWARE DETAILS)



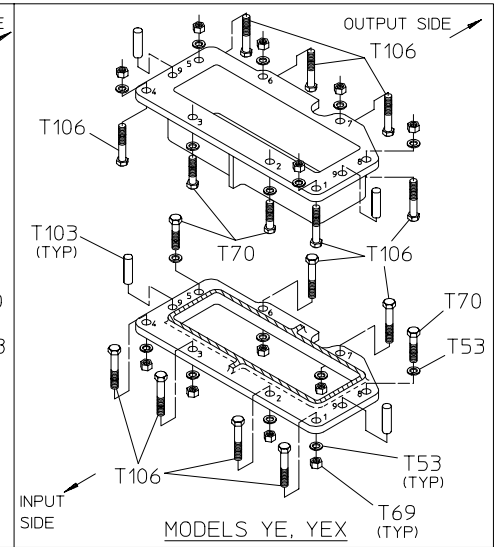
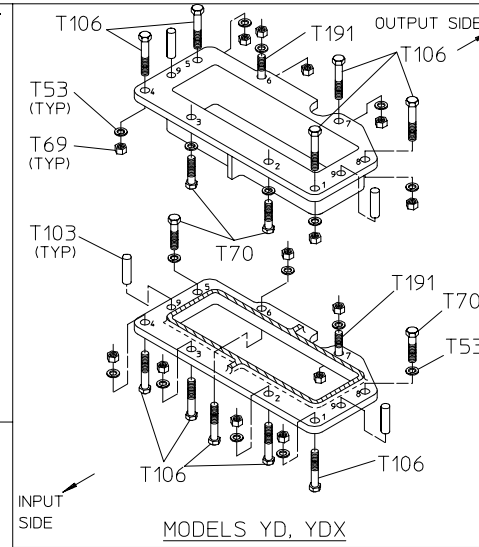
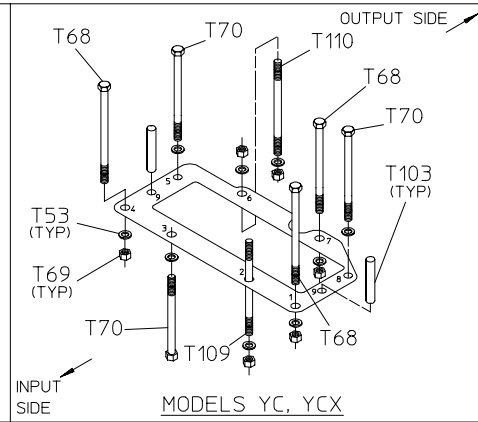
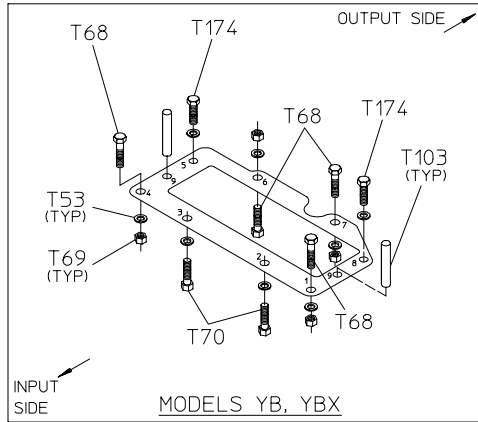

REF NO.	TYPE	THREAD	LENGTH (MODEL)				
			YB, YBX	YC, YCX	YD, YDX	YE, YEX	YF, YFX
T53	LOCKWASHER	1/2	---	---	---	---	---
T68	HEX HD SCREW	1/2-20	2-1/4	4-1/4	---	---	---
T69	HEX NUT	1/2-20	---	---	---	---	---
T70	HEX HD SCREW	1/2-13	1-1/2	3-1/2	1-1/2	1-1/2	1-1/2
T103	DOWEL PIN, 1/2	---	1-1/2	3	1-1/2	1-1/2	1-1/2
T106	HEX HD SCREW	1/2-20	---	---	2	2	2
T109	STUD	1/2-13 x 1/2-20	---	4-1/4	5-1/4 OR 5-3/4	---	---
T110	STUD	1/2-20 x 1/2-20	---	4-3/4	6 OR 6-1/4	---	---
T174	HEX HD SCREW	1/2-13	1-3/4	---	---	---	---
T191	STUD	1/2-20 x 1/2-20	---	---	2-3/4	---	---

HOLE NO.	MODELS YB, YBX ALL RATIOS	MODELS YC, YCX ALL RATIOS	MODELS YD, YDX		MODELS YE, YEX		MODELS YF, YFX	
			ALL RATIOS		ALL RATIOS		ALL RATIOS	
			UPPER	LOWER	UPPER	LOWER	UPPER	LOWER
1	T68	T68	T106	T106	T106	T106	T106	T106
2	T70	T109	T70	T106	T70	T106	T70	T106
3	T70	T70	T70	T106	T70	T106	T70	T106
4	T68	T68	T106	T106	T106	T106	T106	T106
5	T174	T70	T106	T70	T106	T70	T106	T70
6	T68	T110	T191	T106	T106	T106	T106	T106
7	T68	T68	T106	T191	T106	T106	T106	T106
8	T174	T70	T106	T70	T106	T70	T106	T70
9	T103	T103	T103	T103	T103	T103	T103	T103

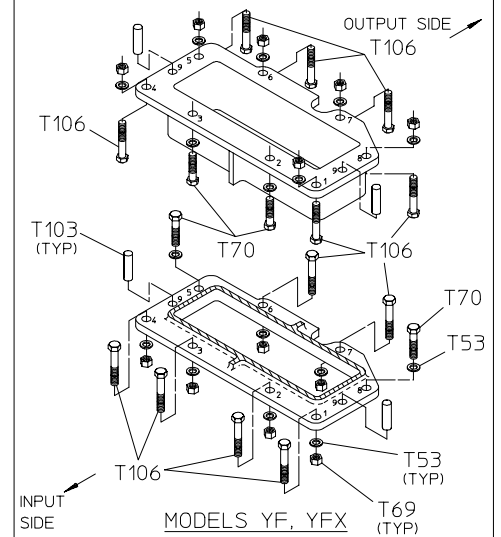

FLANGE HARDWARE BETWEEN CAP (T65) AND CASE (T28)