



Document Number	Issue Date	Rev. Date
SPL82373	03/16/98	09/12/11

Medium Duty K Transmission Assembly Service Parts List

Index:

Pump Model	Impeller Shaft Type	Input Shaft	See Page for Diagram
CLRK, CLVK	One-Piece	1-1/8 in. Keyed	3
		SAE Class C Spline	5
	One-Piece Extended for Compressor Drive	1-1/8 in Keyed	7
		SAE Class C Spline	9
	Transmission Mounting Positions and Pump Mounting Hardware		

Drive Shaft with Keyed Input Shaft

REF. NO.	DESCRIPTION
T1	Woodruff Key
T2	Serial Plate
T4	Gasket
T6	Gasket
T8	Gasket
T9	Bearing Cover
T10	Bearing Cover
T11	Drive Shaft
T13	Gear Case Subassembly
T14	Dowel Pin, 3/8 x 1 in.
T15	Drive Gear
T17	Breather, 1/2 in.
T18	Magnetic Drain Plug, 1/2 in.
T19	Hex Hd Screw, 3/8-16 x 1-1/4 in. Grade 5
T24	Oil Seal
T25	Lock Washer, 3/8 in.

REF. NO.	DESCRIPTION
T28	Retaining Ring
T31	Pipe Plug, 1/2 in.
T32	Drive Screw, No. 6 x 1/4 in.
T33	Ball Bearing
T34	Ball Bearing
T50	Oil Seal
T67	Oil Level Plate
T69	Street Elbow 45 Degrees, 1/2 in.
T75	Bearing Spacer
T76	Key, .125 x .187 x 2-19/32 in.
T77	Self Locking Castle Nut
T79	Plain Washer, 3/4 in.
T80	Cotter Pin, 1/8 x 1-1/2 in.
T87	Adapter Bushing
T92	Hex Hd Screw, 3/8-16 x 1 in.

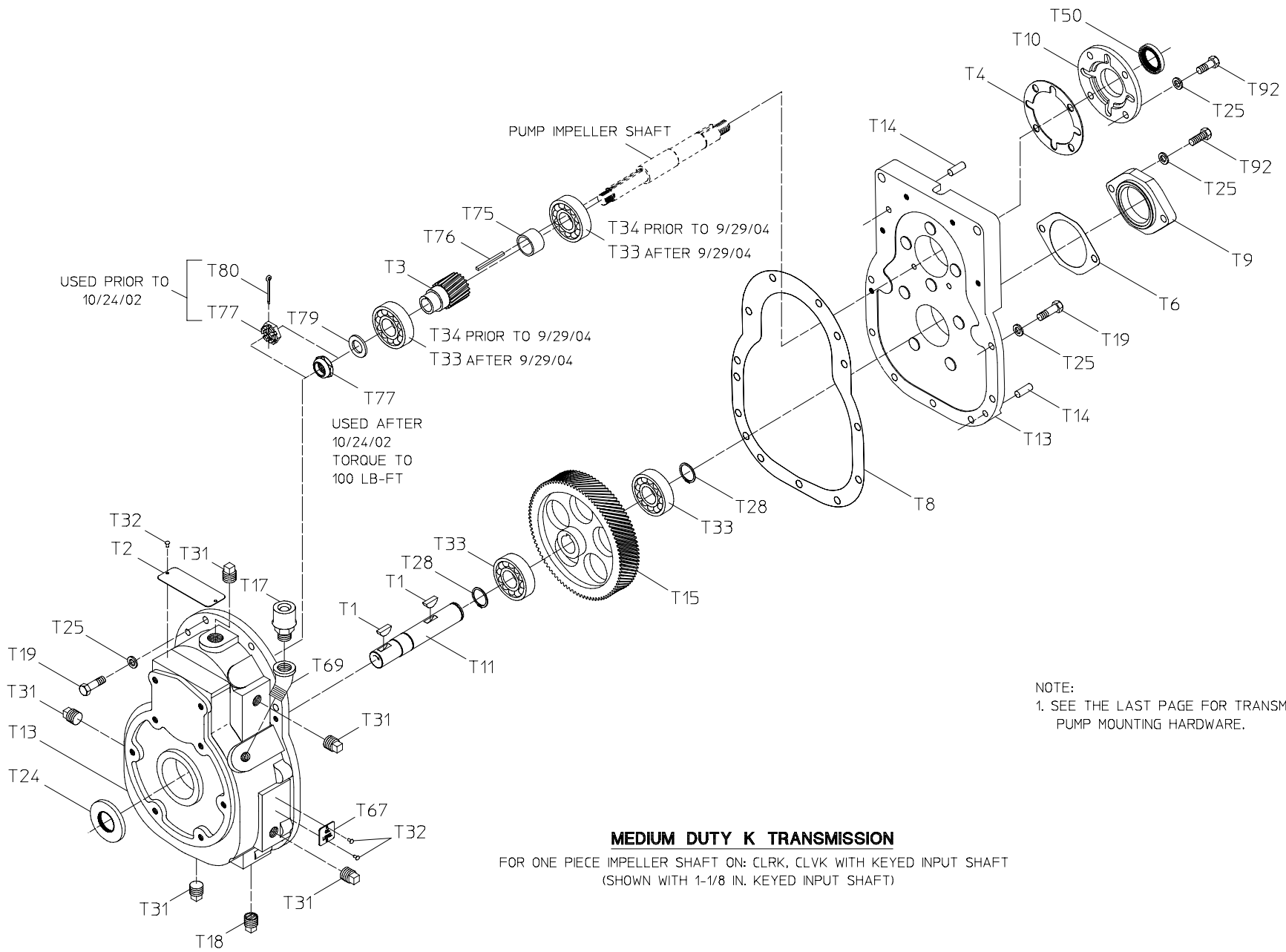

MEDIUM DUTY K TRANSMISSION

FOR ONE PIECE IMPELLER SHAFT ON: CLRK, CLVK WITH KEYED INPUT SHAFT
(SHOWN WITH 1-1/8 IN. KEYED INPUT SHAFT)

Drive Shaft

REF. NO.	DESCRIPTION
T1	Woodruff Key
T2	Serial Plate
T3	Driven Gear
T4	Gasket
T6	Gasket
T8	Gasket
T9	Bearing Cover
T10	Bearing Cover
T11	Drive Shaft
T13	Gear Case Subassembly
T14	Dowel Pin, 3/8 x 1 in.
T15	Drive Gear
T17	Breather, 1/2 in.
T18	Magnetic Drain Plug, 1/2 in.
T19	Hex Hd Screw, 3/8-16 x 1-1/4 in. Grade 5
T24	Oil Seal
T25	Lock Washer, 3/8 in.

REF. NO.	DESCRIPTION
T28	Retaining Ring
T31	Pipe Plug, 1/2 in.
T32	Drive Screw, No. 6 x 1/4 in.
T33	Ball Bearing
T34	Ball Bearing
T50	Oil Seal
T67	Oil Level Plate
T69	Street Elbow 45 Degrees, 1/2 in.
T75	Bearing Spacer
T76	Key, .125 x .187 x 2-19/32 in.
T77	Self Locking Castle Nut
T79	Plain Washer, 3/4 in.
T80	Cotter Pin, 1/8 x 1-1/2 in.
T87	Adapter Bushing
T88	Case Adapter
T91	Socket Hd Screw, 7/16-0 x 1-1/4 in.
T92	Hex Hd Screw, 3/8-16 x 1 in.

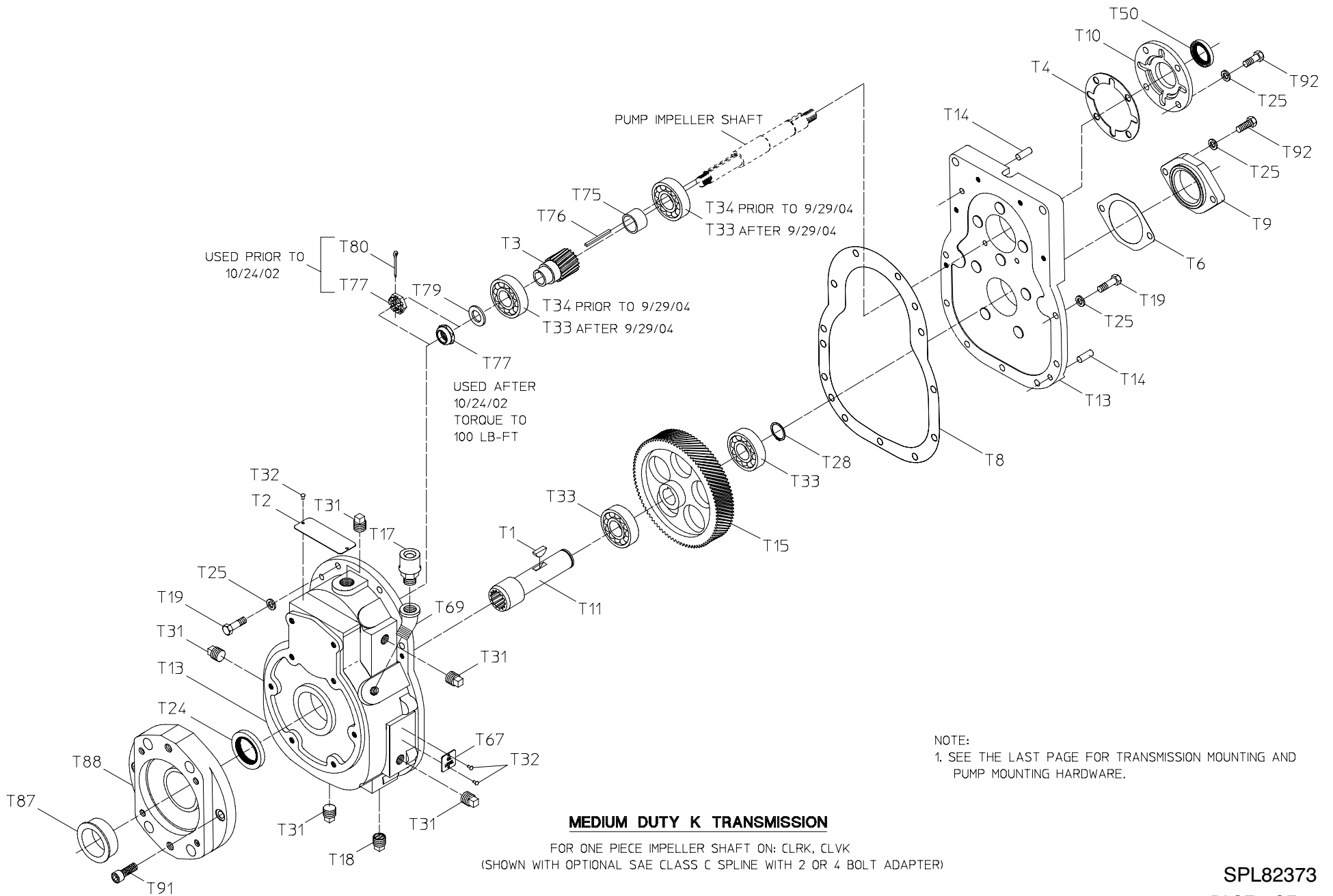

NOTE:
 1. SEE THE LAST PAGE FOR TRANSMISSION MOUNTING AND PUMP MOUNTING HARDWARE.

MEDIUM DUTY K TRANSMISSION

FOR ONE PIECE IMPELLER SHAFT ON: CLRK, CLVK
 (SHOWN WITH OPTIONAL SAE CLASS C SPLINE WITH 2 OR 4 BOLT ADAPTER)

Compressor Drive

REF. NO.	DESCRIPTION
T1	Woodruff Key
T2	Serial Plate
T3	Driven Gear
T4	Gasket
T5	Bearing Spacer
T6	Gasket
T7	Retaining Ring
T8	Gasket
T9	Bearing Cover
T10	Bearing Cover
T11	Drive Shaft
T13	Gear Case Subassembly
T14	Dowel Pin, 3/8 x 1 in.
T15	Drive Gear
T17	Breather, 1/2 in.
T18	Magnetic Drain Plug, 1/2 in.
T19	Hex Hd Screw, 3/8-16 x 1-1/4 in. Grade 5
T24	Oil Seal
T25	Lock Washer, 3/8 in.

REF. NO.	DESCRIPTION
T28	Retaining Ring
T31	Pipe Plug, 1/2 in.
T32	Drive Screw, No. 6 x 1/4 in.
T33	Ball Bearing
T34	Ball Bearing
T50	Oil Seal
T67	Oil Level Plate
T69	Street Elbow 45 Degrees, 1/2 in.
T75	Bearing Spacer
T76	Key, .125 x .187 x 2-19/32 in.
T92	Hex Hd Screw, 3/8-16 x 1 in.
T94	Square Key, 5/16 x 2-15/16 in.
T106	Oil Seal
T109	Bearing Lock - Nut
T110	Bearing Lock - Washer

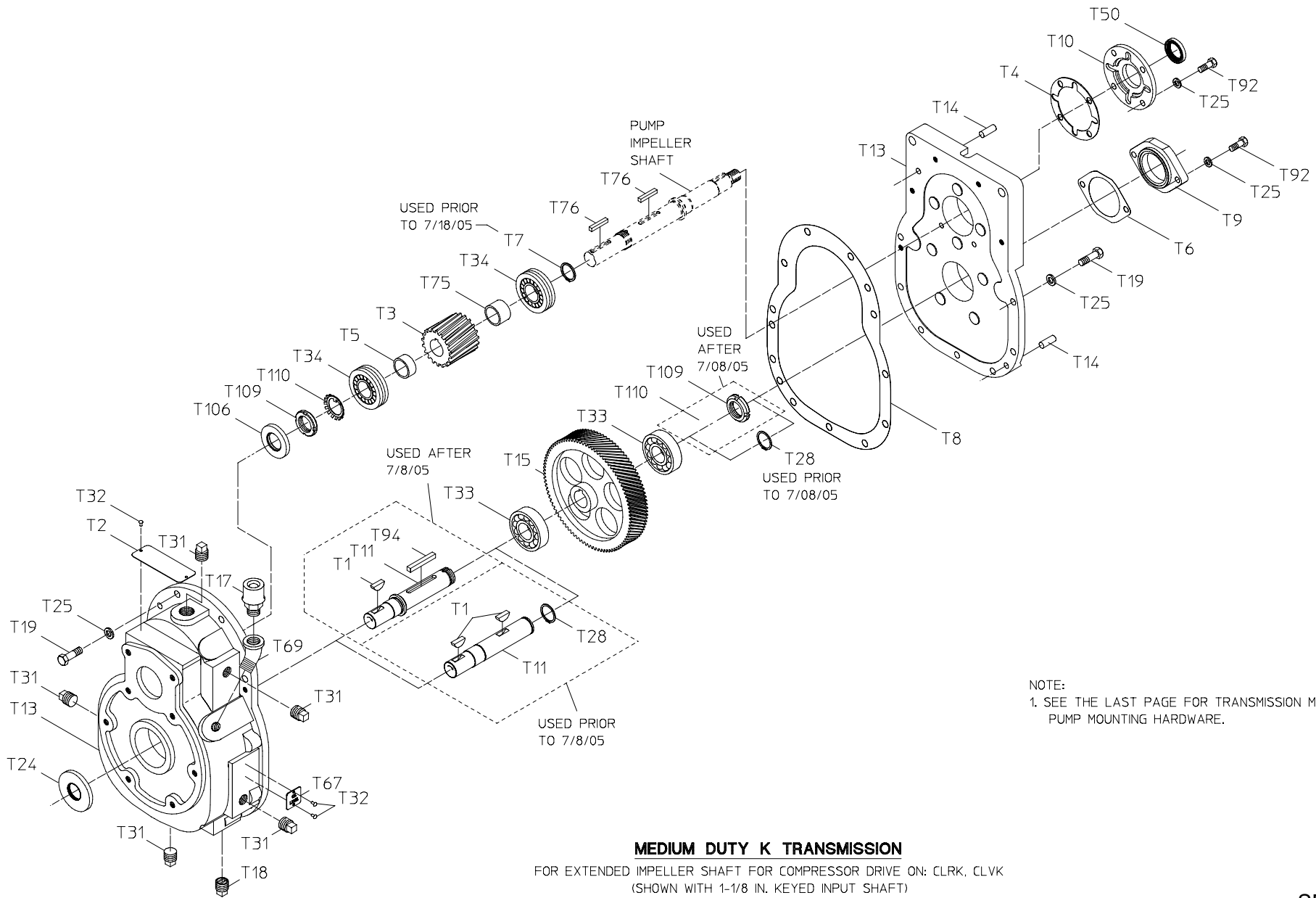

MEDIUM DUTY K TRANSMISSION

FOR EXTENDED IMPELLER SHAFT FOR COMPRESSOR DRIVE ON: CLRK, CLVK
(SHOWN WITH 1-1/8 IN. KEYED INPUT SHAFT)

Extended Impeller Shaft

REF. NO.	DESCRIPTION
T1	Woodruff Key
T2	Serial Plate
T3	Driven Gear
T4	Gasket
T5	Bearing Spacer
T6	Gasket
T7	Retaining Ring
T8	Gasket
T9	Bearing Cover
T10	Bearing Cover
T11	Drive Shaft
T13	Gear Case Subassembly
T14	Dowel Pin, 3/8 x 1 in.
T15	Drive Gear
T17	Breather, 1/2 in.
T18	Magnetic Drain Plug, 1/2 in.
T19	Hex Hd Screw, 3/8-16 x 1-1/4 in. Grade 5
T24	Oil Seal
T25	Lock Washer, 3/8 in.

REF. NO.	DESCRIPTION
T28	Retaining Ring
T31	Pipe Plug, 1/2 in.
T32	Drive Screw, No. 6 x 1/4 in.
T33	Ball Bearing
T34	Ball Bearing
T50	Oil Seal
T67	Oil Level Plate
T69	Street Elbow 45 Degrees, 1/2 in.
T75	Bearing Spacer
T76	Key, .125 x .187 x 2-19/32 in.
T88	Case Adapter
T92	Hex Hd Screw, 3/8-16 x 1 in.
T94	Square Key, 5/16 x 2-15/16 in.
T106	Oil Seal
T109	Bearing Lock - Nut
T110	Bearing Lock - Washer

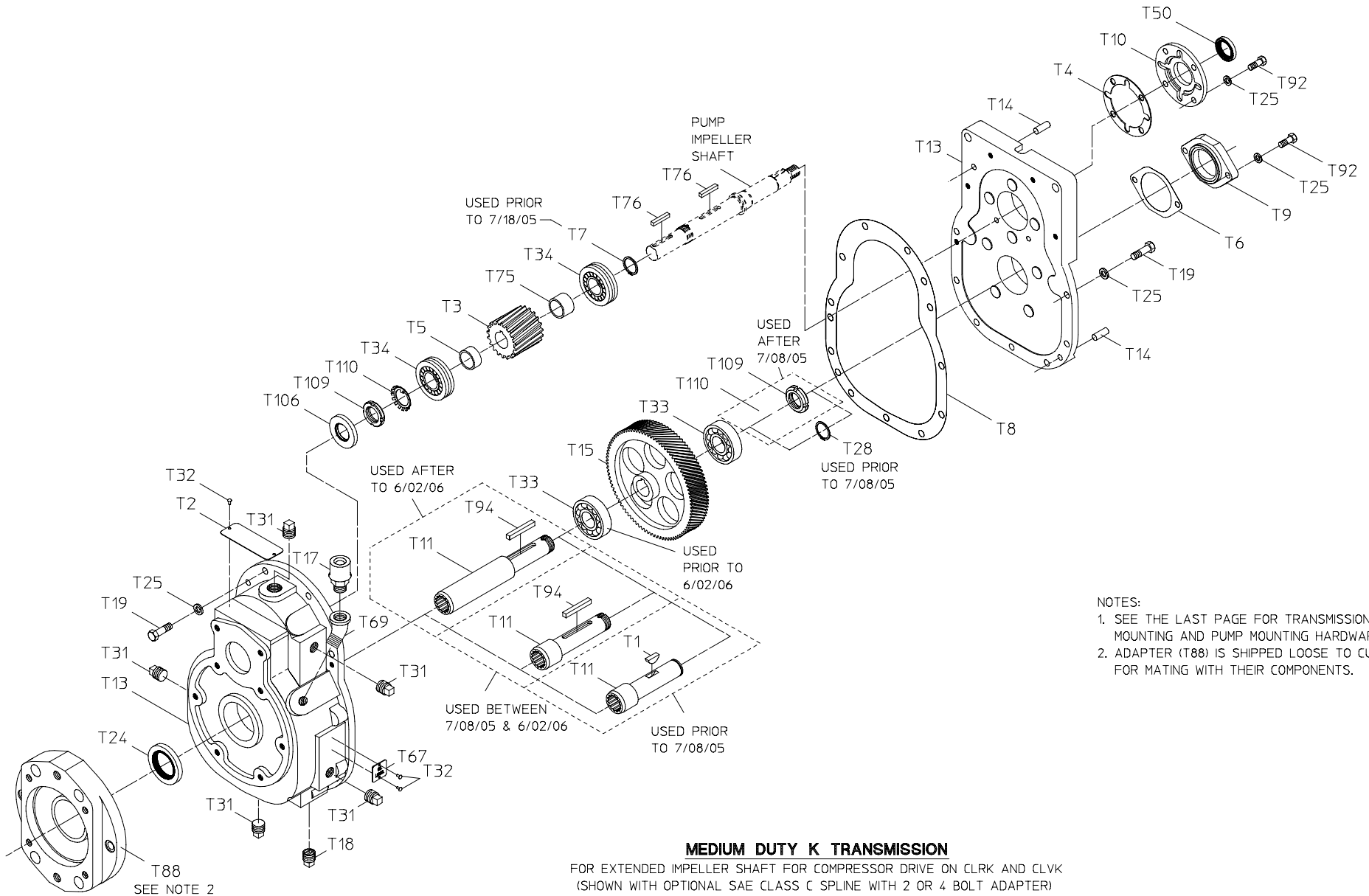

MEDIUM DUTY K TRANSMISSION

FOR EXTENDED IMPELLER SHAFT FOR COMPRESSOR DRIVE ON CLRK AND CLVK
(SHOWN WITH OPTIONAL SAE CLASS C SPLINE WITH 2 OR 4 BOLT ADAPTER)

Transmission Mounting Positions and Pump Mounting Hardware

REF. NO.	DESCRIPTION
T17	Breather, 1/2 in.
T18	Magnetic Drain Plug, 1/2 in.
T20	Hex Hd Screw, 7/16-14 x 1-1/4 in.
T21	Hex Head Screw, 1/2-13 x 1-1/2 in.
T22	Hex Head Screw, 1/2-20 x 2-3/4 in.
T23	Hex Nut, 1/2-20
T26	Lock Washer, 7/16 in.

REF. NO.	DESCRIPTION
T27	Lock Washer, 1/2 in.
T31	Pipe Plug, 1/2 in.
T32	Drive Screw, No. 6 x 1/4 in.
T56	Suspension Pin, 1 x 2-5/8 in.
T57	Suspension Bracket
T59	Cotter Pin, 5/16 x 2-1/2 in.
T67	Oil Level Plate
T69	Street Elbow, 45 Degrees, 1 x 1/2 in.

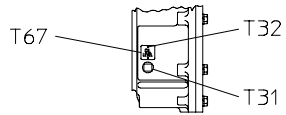

VIEW A-A

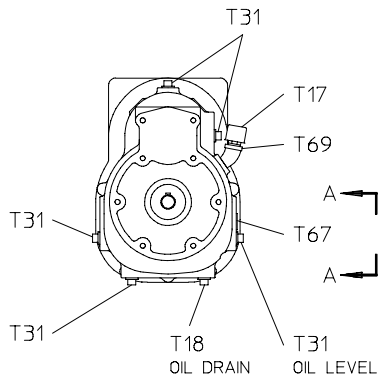

VERTICAL POSITION

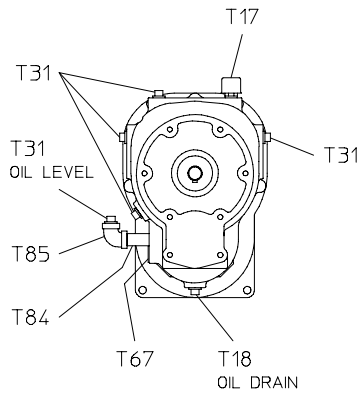

INVERTED POSITION

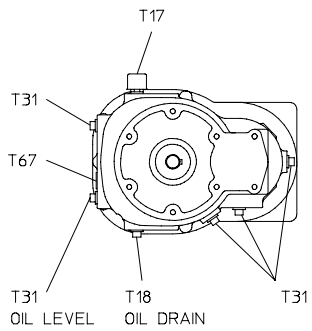

LEFT SIDE POSITION

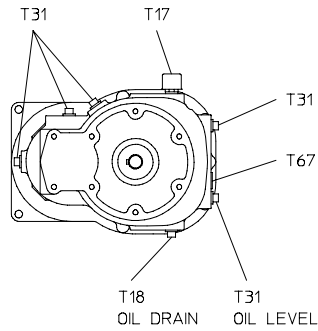

RIGHT SIDE POSITION

TRANSMISSION MOUNTING POSITIONS

OPTIONAL SUSPENSION PIN MOUNTING

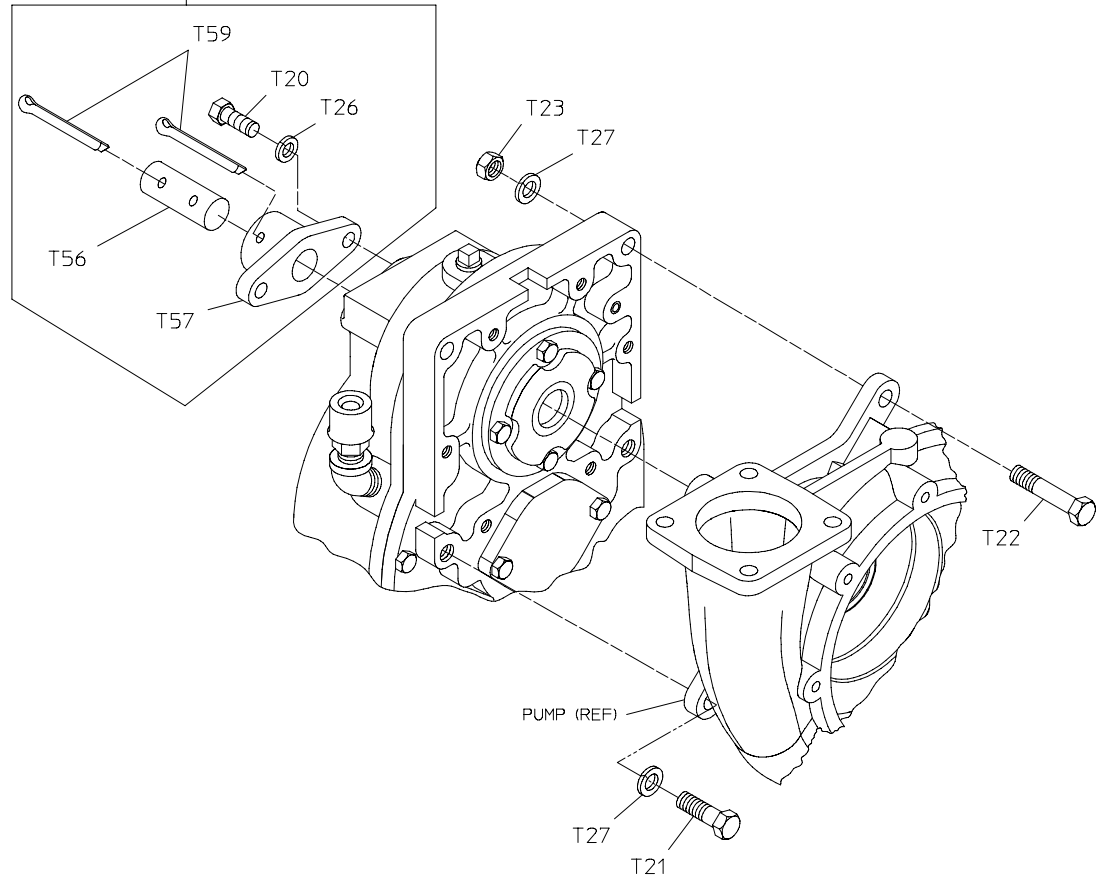

PUMP MOUNTING HARDWARE