



Document Number	Issue Date	Rev. Date
<b>SPL82392</b>	<b>10/15/98</b>	<b>MMS</b>

## Drive Assembly for Eclipse™ CAFS Service Parts List

### Index:

Belt Guard Design	Component	See Page
<b>Two-Piece</b> (Pumps built after December 8, 2008)	Clutch and Belt	2, 3
	Mounting Bracket and Air Line	4, 5
<b>One-Piece</b> (Pumps built prior to December 8, 2008)	Clutch and Belt	6, 7
	Mounting Bracket and Air Line	8, 9

## Clutch and Belt, Two-Piece Guard Design Pumps Built After December 8, 2008

REF. NO.	DESCRIPTION
1	Driven sprocket
2	Drive sprocket
3	Drive belt
6	Idler sprocket
7	Air clutch
11	Nylon tubing, 1/4, 10 in.
12	Sprocket retainer
18	Hex hd screw, 16mm x 40mm
19	Lock washer, 16mm
24	Lock washer, 8mm
26	Internal lock washer, 3/4 in.
27	Bushing
29	Female elbow, 1/4 tube x 1/8 NPT
30	Pipe nipple, 1/8 x 4-1/2 in.
31	Set screw, 3/8-24 x 3/8 in.

REF. NO.	DESCRIPTION
32	Set screw, 3/8-24 x 3/4 in.
33	Air clutch subassembly
46	Hex hd screw, 8mm x 25mm
48	Air clutch repair kit
60	Air clutch rotating union repair kit
61	Belt guard, two-piece design
65	Waterous decal
67	Hex hd screw, 1/4-20 x 5/8 in.
68	Plain washer, 1/4 in.

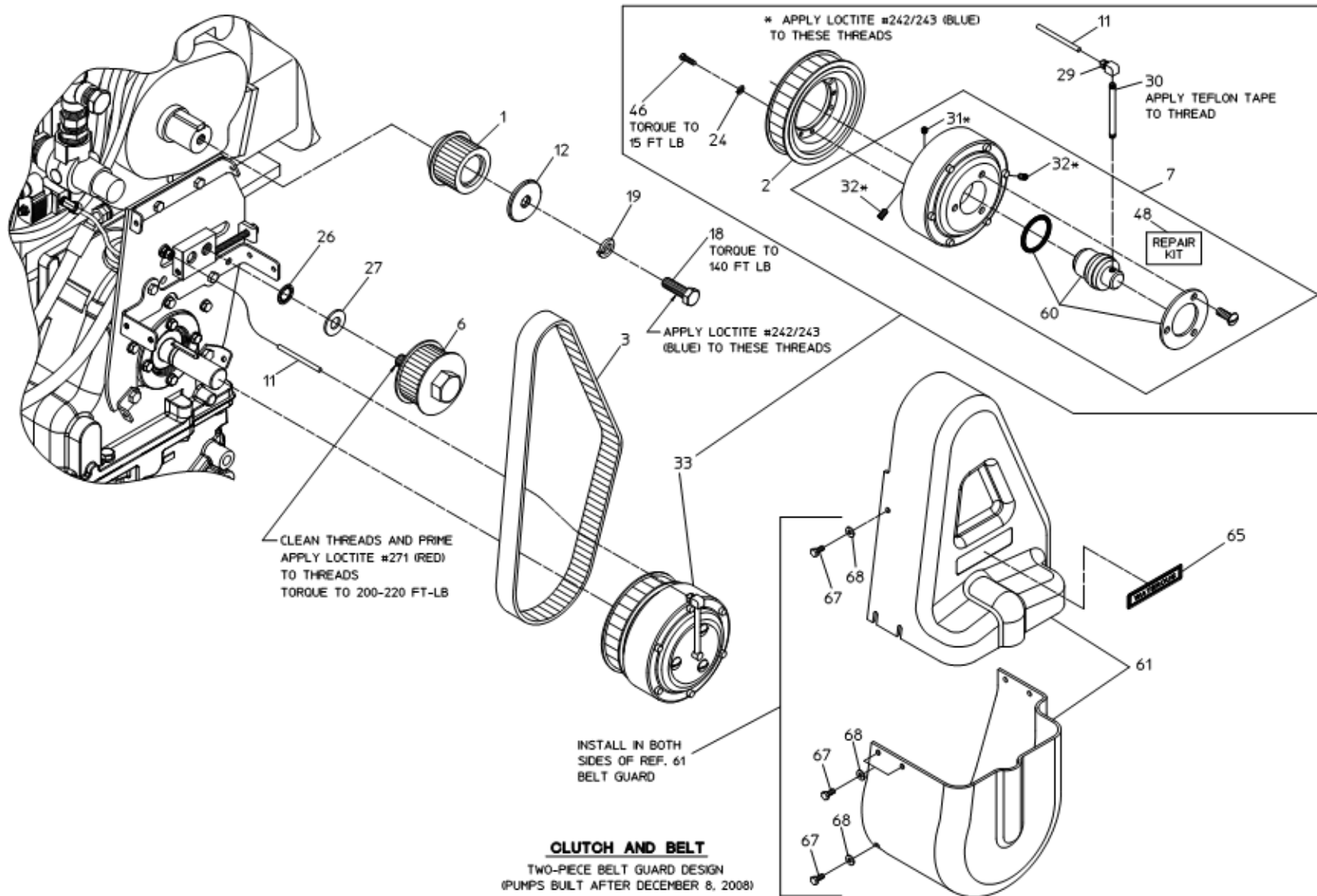

## Mounting Bracket and Air Line, Two-Piece Guard Design Pumps Built After December 8, 2008

REF. NO.	DESCRIPTION
4	Idler plate
10	1/4 tube, bulkhead union
11	Nylon tubing, 1/4, 10 in.
13	Lock washer, 7/16 in.
15	Lock washer, 3/8 in.
16	Hex hd screw, 3/8-24 x 5-1/2 in.
17	Plain washer, 3/8 in.
20	Hex hd screw, 3/4-16 x 1 in. or 3/4-16 x 1-1/4 in.
21	Plain washer, 3/4 in.
22	Lock washer, 3/4 in.
25	Hex nut, 3/8-16
58	Hex hd screw, 10mm x 20mm
59	Lock washer, 10mm
62	Upper belt guard bracket
63	Middle belt guard bracket

REF. NO.	DESCRIPTION
64	Lower belt guard bracket
66	Hex hd screw, 3/8-16 x 1 in.

CLEAN THREADS AND PRIME  
APPLY LOCTITE #242/243 (BLUE) TO  
THREADS AT TIME OF BELT ADJUSTMENT  
TORQUE TO 200-220 FT-LB

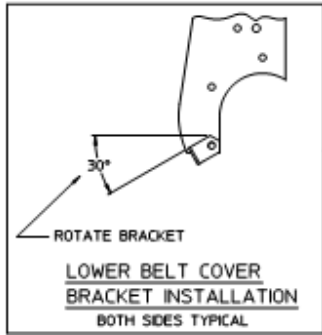
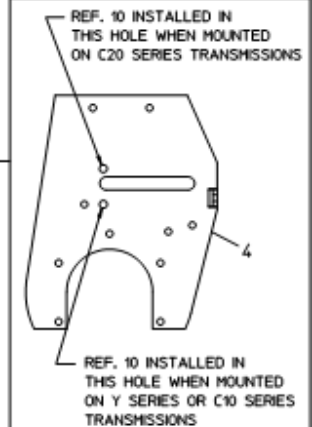
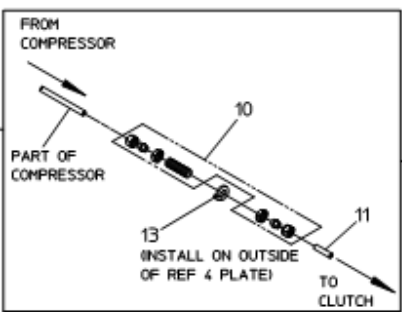
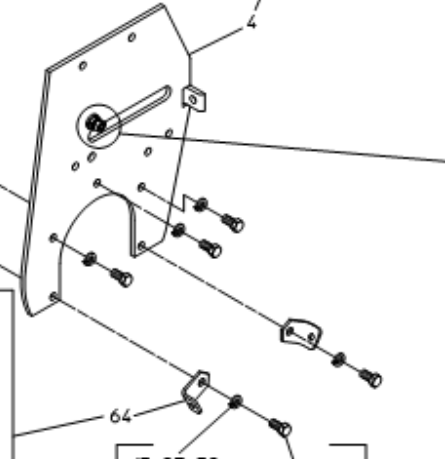
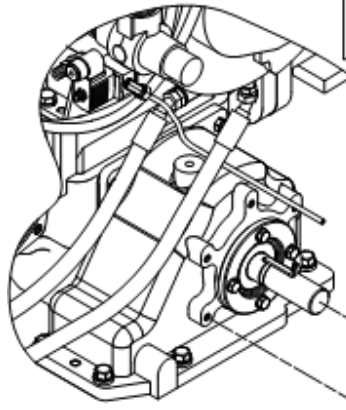
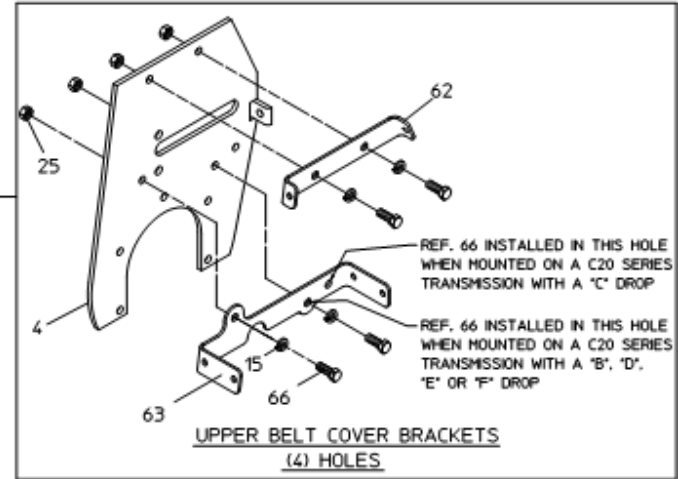
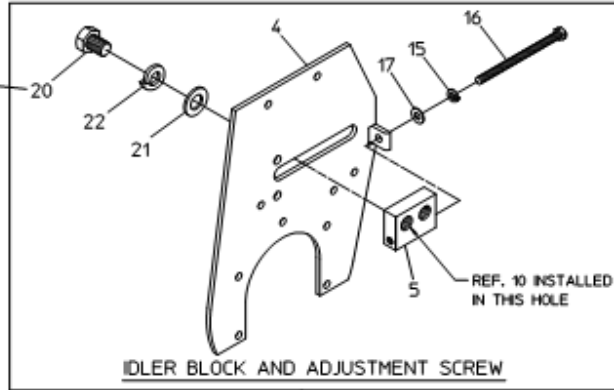

**MOUNTING BRACKET AND AIR LINE**  
TWO-PIECE BELT GUARD DESIGN  
(PUMPS BUILT AFTER DECEMBER 8, 2008)

## Clutch and Belt, One-Piece Guard Design Pumps Built Prior to December 8, 2008

REF. NO.	DESCRIPTION
1	Driven sprocket
2	Drive sprocket
3	Drive belt
6	Idler sprocket
7	Air clutch
9	Belt guard
11	Nylon tubing, 1/4, 10 in.
12	Sprocket retainer
15	Lock washer, 3/8 in.
17	Plain washer, 3/8 in.
18	Hex hd screw, 16mm x 40mm
19	Lock washer, 16mm
23	Socket hd screw, 8mm x 25mm
24	Lock washer, 8mm
25	Hex nut, 3/8-16

REF. NO.	DESCRIPTION
26	Internal lock washer, 3/4 in.
27	Bushing
28	Tube connector, 1/4 in.
29	Female elbow, 1/4 tube x 1/8 NPT
30	Pipe nipple, 1/8 x 4-1/2 in.
31	Set screw, 3/8-24 x 3/8 in.
32	Set screw, 3/8-24 x 3/4 in.
33	Air clutch subassembly
46	Hex hd screw, 8mm x 25mm
48	Air clutch repair kit
60	Air clutch rotating union repair kit

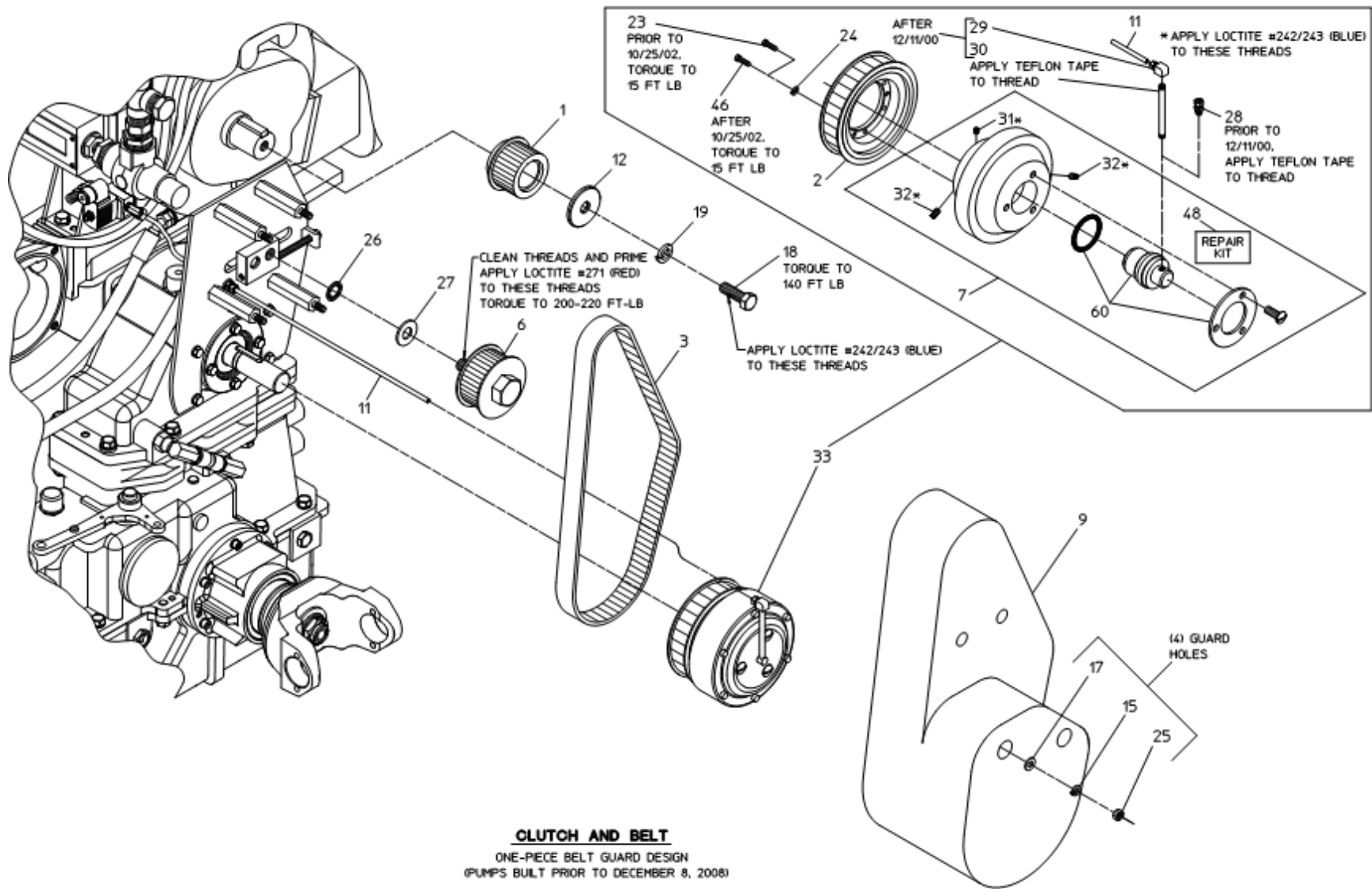

## Mounting Bracket and Air Line, One-Piece Guard Design Pumps Built Prior to December 8, 2008

REF. NO.	DESCRIPTION
4	Idler plate
5	Idler adjustment block
8	Standoff
10	1/4 tube, bulkhead union
11	Nylon tubing, 1/4, 10 in.
13	Lock washer, 7/16 in.
14	Hex hd screw, 3/8-16 x 3/4 in.
15	Lock washer, 3/8 in.
16	Hex hd screw, 3/8-24 x 5-1/2 in.
17	Plain washer, 3/8 in.
20	Hex hd screw, 3/4-16 x 1 in.
21	Plain washer, 3/4 in.
22	Lock washer, 3/4 in.
25	Hex nut, 3/8-16
58	Hex hd screw, 10mm x 20mm

REF. NO.	DESCRIPTION
59	Lock washer, 10mm



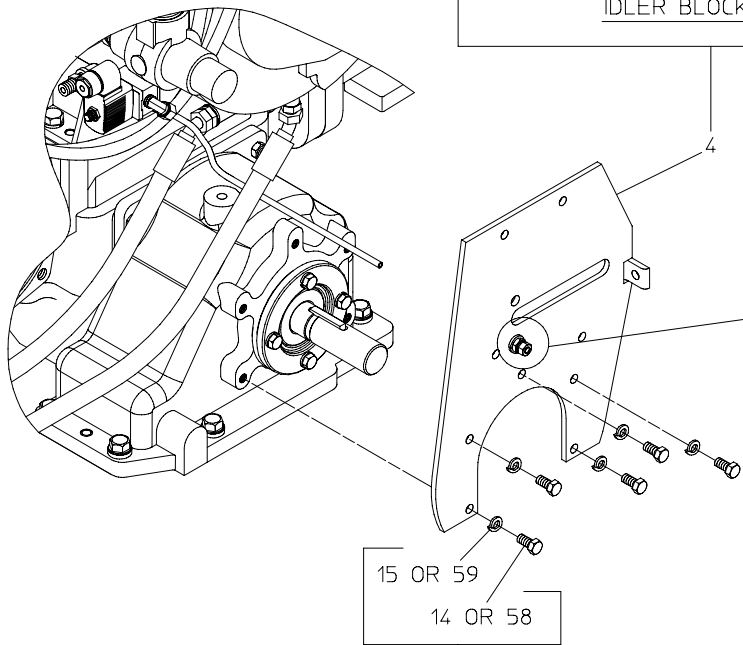
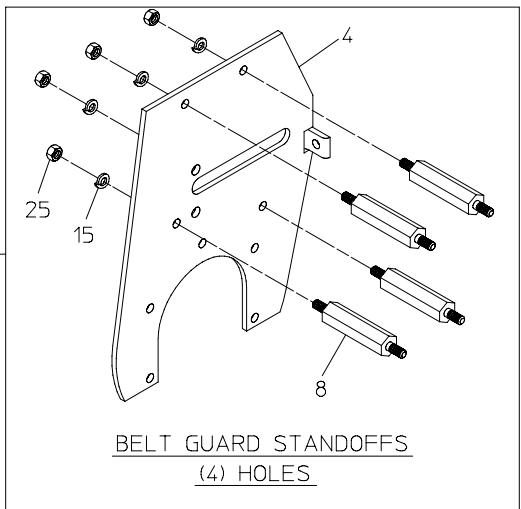
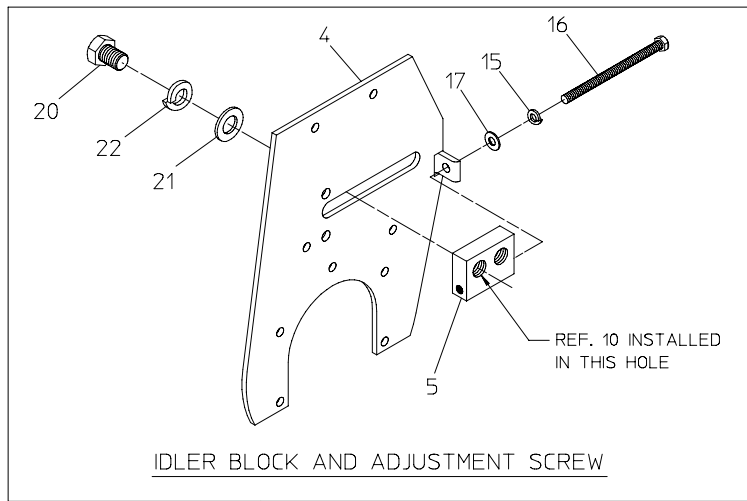

CONNECTION TO  
TRANSMISSION, (5) HOLES

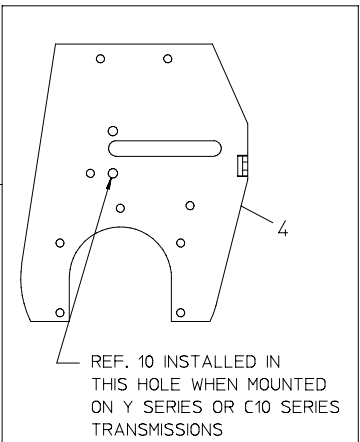
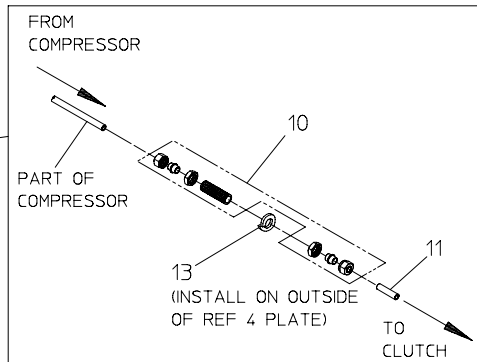

**MOUNTING BRACKET AND AIR LINE**

ONE-PIECE BELT GUARD DESIGN  
(PUMPS BUILT PRIOR TO DECEMBER 8, 2008)

DRIVE ASSEMBLY FOR ECLIPSE CAFS

SPL82392

WATEROUS COMPANY

SOUTH ST. PAUL, MN 55075

PAGE 9 OF 9