

## S100 Series Impeller Shaft Service Parts List

Pump Model	Complete Pump and Transmission Model (Located on Pump Serial Plate)						Pump Mounting on Transmission	See Pages
	C10 Series	P Series	C20 Series	C22 Series	D Series (Direct Drive)	QC Series		
S101	--	--	S101C20B S101C20C S101C20D S101C20E S101C20F	S101C22B S101C22C S101C22D S101C22E S101C22F	--	--	Front (Input Shaft Side)	2
S100	S100C10B S100C10C S100C10D S100C10E S100C10F	--	S100C20B S100C20C S100C20D S100C20E S100C20F	S100C22B S100C22C S100C22D S100C22E S100C22F	--	--	Rear (Output Shaft Side)	3
	--	S100PA	--	--	--	--	Front (Input Shaft Side)	4
	--	--	--	--	S100D	--	--	5
	--	--	--	--	--	S100QC	Rear (Output Shaft Side)	6
	--	--	Optional Impeller Inducer					7

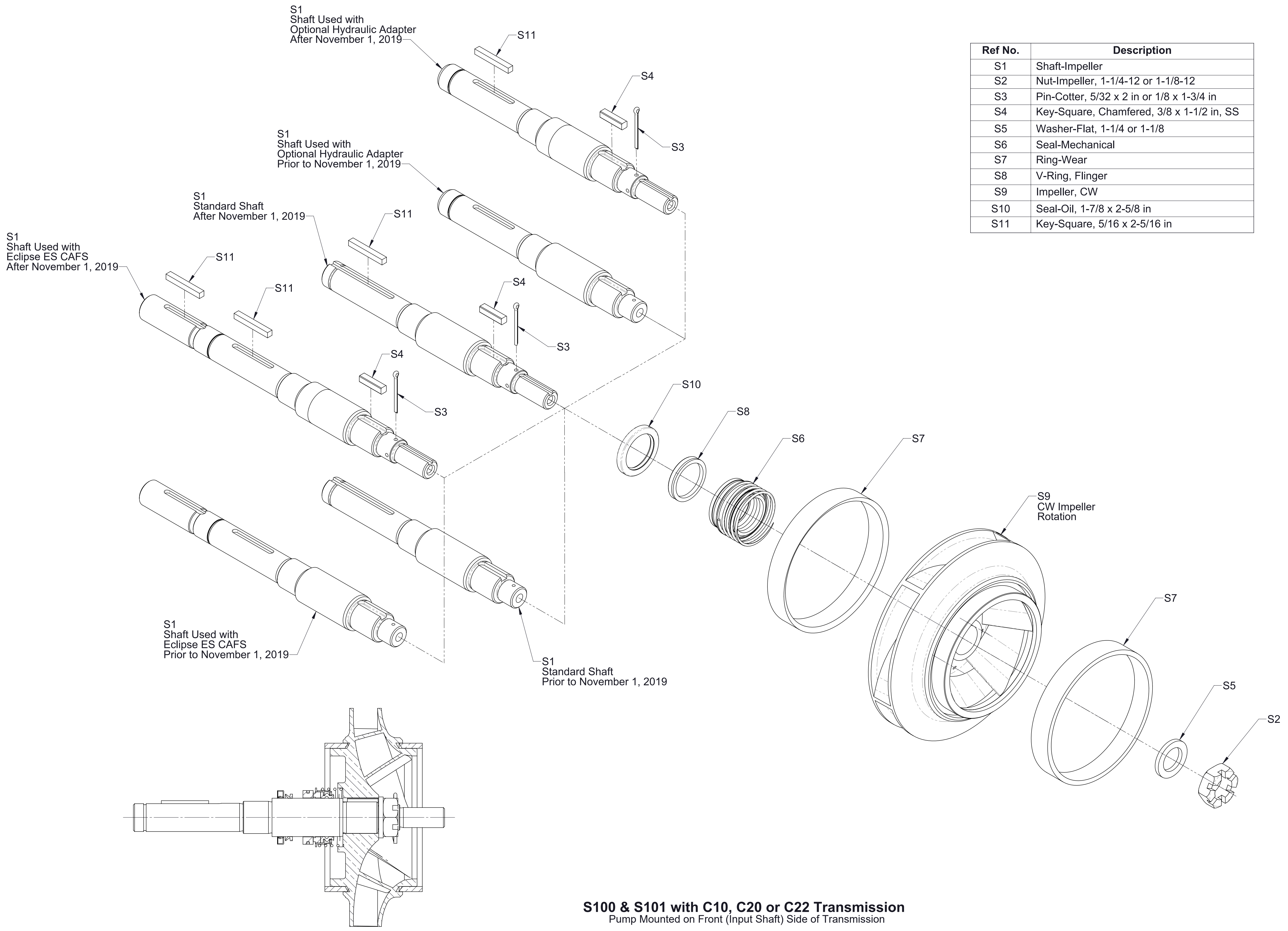

Ref No.	Description
S1	Shaft-Impeller
S2	Nut-Impeller, 1-1/4-12 or 1-1/8-12
S3	Pin-Cotter, 5/32 x 2 in or 1/8 x 1-3/4 in
S4	Key-Square, Chamfered, 3/8 x 1-1/2 in, SS
S5	Washer-Flat, 1-1/4 or 1-1/8
S6	Seal-Mechanical
S7	Ring-Wear
S8	V-Ring, Flinger
S9	Impeller, CW
S10	Seal-Oil, 1-7/8 x 2-5/8 in
S11	Key-Square, 5/16 x 2-5/16 in

**S100 & S101 with C10, C20 or C22 Transmission**  
 Pump Mounted on Front (Input Shaft) Side of Transmission

**Sectional View**

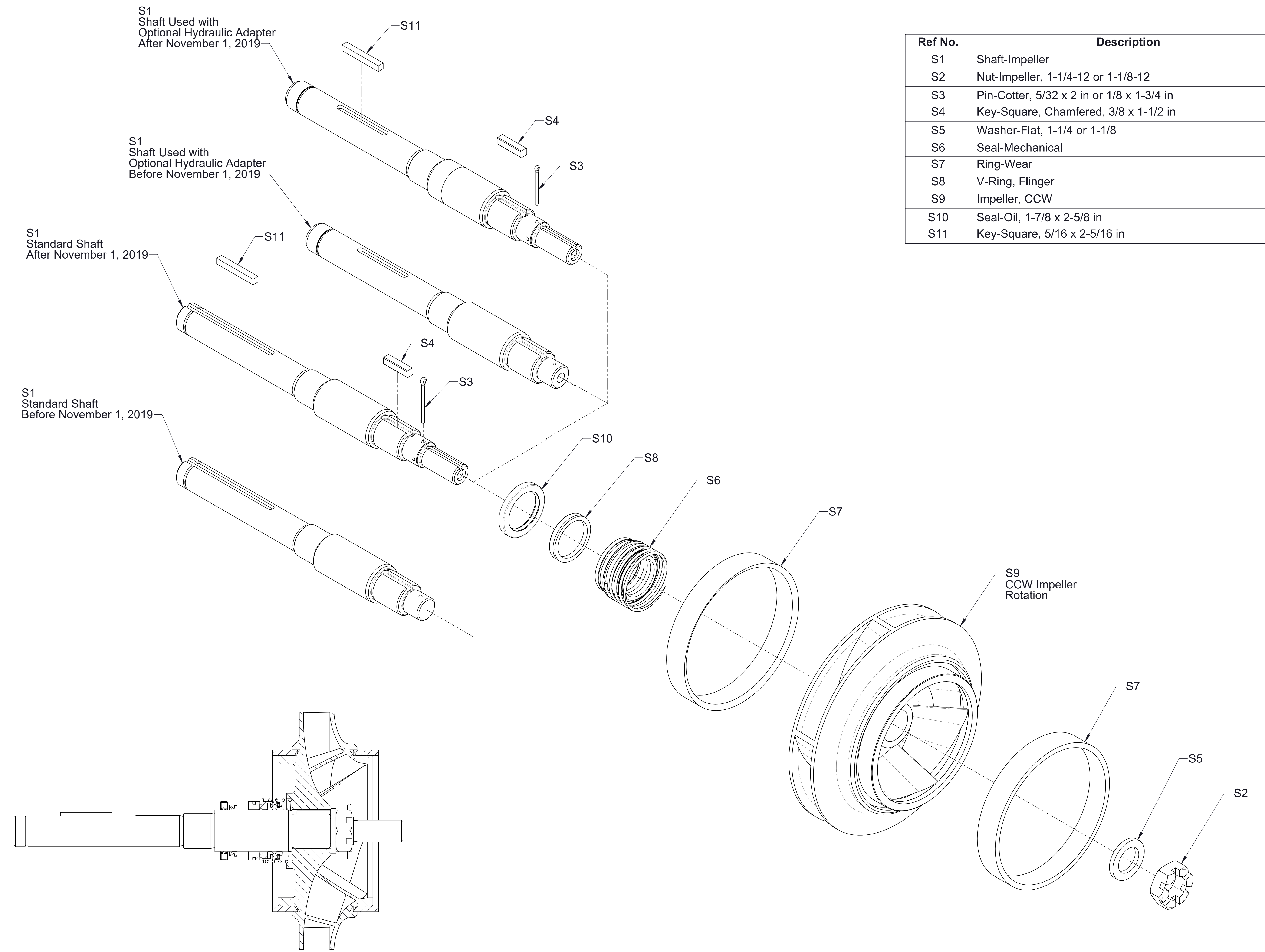

Ref No.	Description
S1	Shaft-Impeller
S2	Nut-Impeller, 1-1/4-12 or 1-1/8-12
S3	Pin-Cotter, 5/32 x 2 in or 1/8 x 1-3/4 in
S4	Key-Square, Chamfered, 3/8 x 1-1/2 in
S5	Washer-Flat, 1-1/4 or 1-1/8
S6	Seal-Mechanical
S7	Ring-Wear
S8	V-Ring, Flinger
S9	Impeller, CCW
S10	Seal-Oil, 1-7/8 x 2-5/8 in
S11	Key-Square, 5/16 x 2-5/16 in

**Sectional View**

**S100 with C10, C20 or C22 Transmission**  
 Pump Mounted on Rear (Output Shaft) Side of Transmission

Ref No.	Description
S1	Shaft-Impeller
S2	Nut-Impeller, 1-1/8-12
S3	Pin-Cotter, 1/8 x 1-3/4 in
S4	Key-Square, Chamfered, 3/8 x 1-1/2 in
S5	WASHER-PLAIN, SAE STANDARD
S6	Seal-Mechanical
S7	Ring-Wear
S8	V-Ring, Flinger
S9	Impeller, CW
S10	Seal-Oil, 1-7/8 x 2-5/8 in
S11	Key-Square, 5/16 x 2-5/16 in

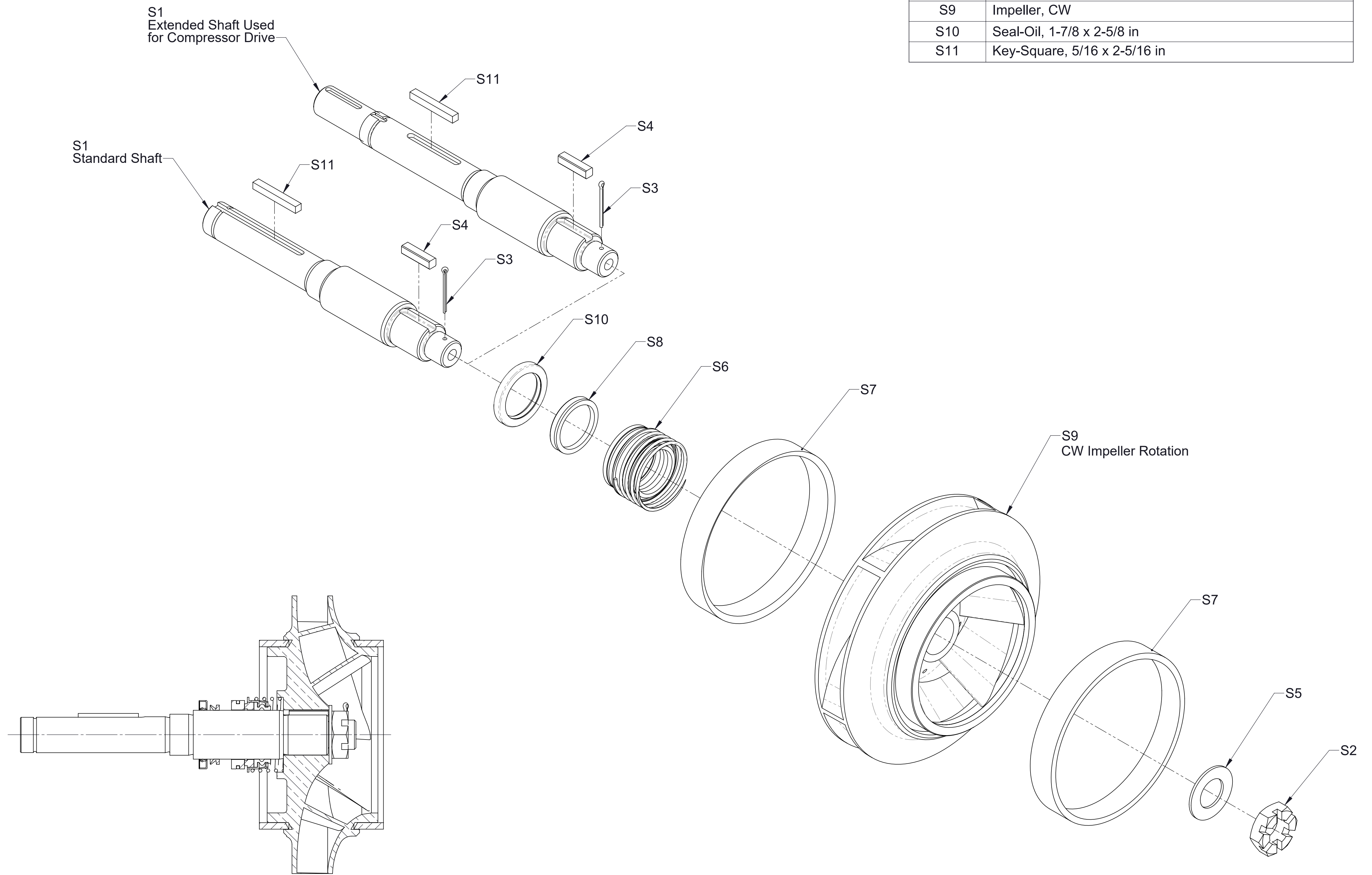

**Sectional View**

**S100 with PA Transmission**  
 Pump Mounted on Front (Input Shaft) Side of Transmission

Ref No.	Description
S1	Shaft-Impeller
S2	Nut-Impeller, 1-1/4-12 or 1-1/8-12
S3	Pin-Cotter, 5/32 x 2 in or 1/8 x 1-3/4 in
S4	Key-Square, Chamfered, 3/8 x 1-1/2 in
S5	Washer-Flat, 1-1/4 or 1-1/8
S6	Seal-Mechanical
S7	Ring-Wear
S8	V-Ring, Flinger
S9	Impeller
S10	Seal-Oil, 1-7/8 x 2-5/8 in
S12	Bearing, Ball, Double Row
S13	Nut-Lock, Bearing, N08
S14	Washer-Lock, Bearing, W08
S15	Ring-Retaining, External, Heavy Duty, 1-3/8 in Shaft Dia
S16	Bearing, Ball, Single Row
S17	Seal-Oil, 1-23/32 x 2-5/8 in
S18	End Yoke
S19	Nut-Self Locking, 1-20 UNEF-2B

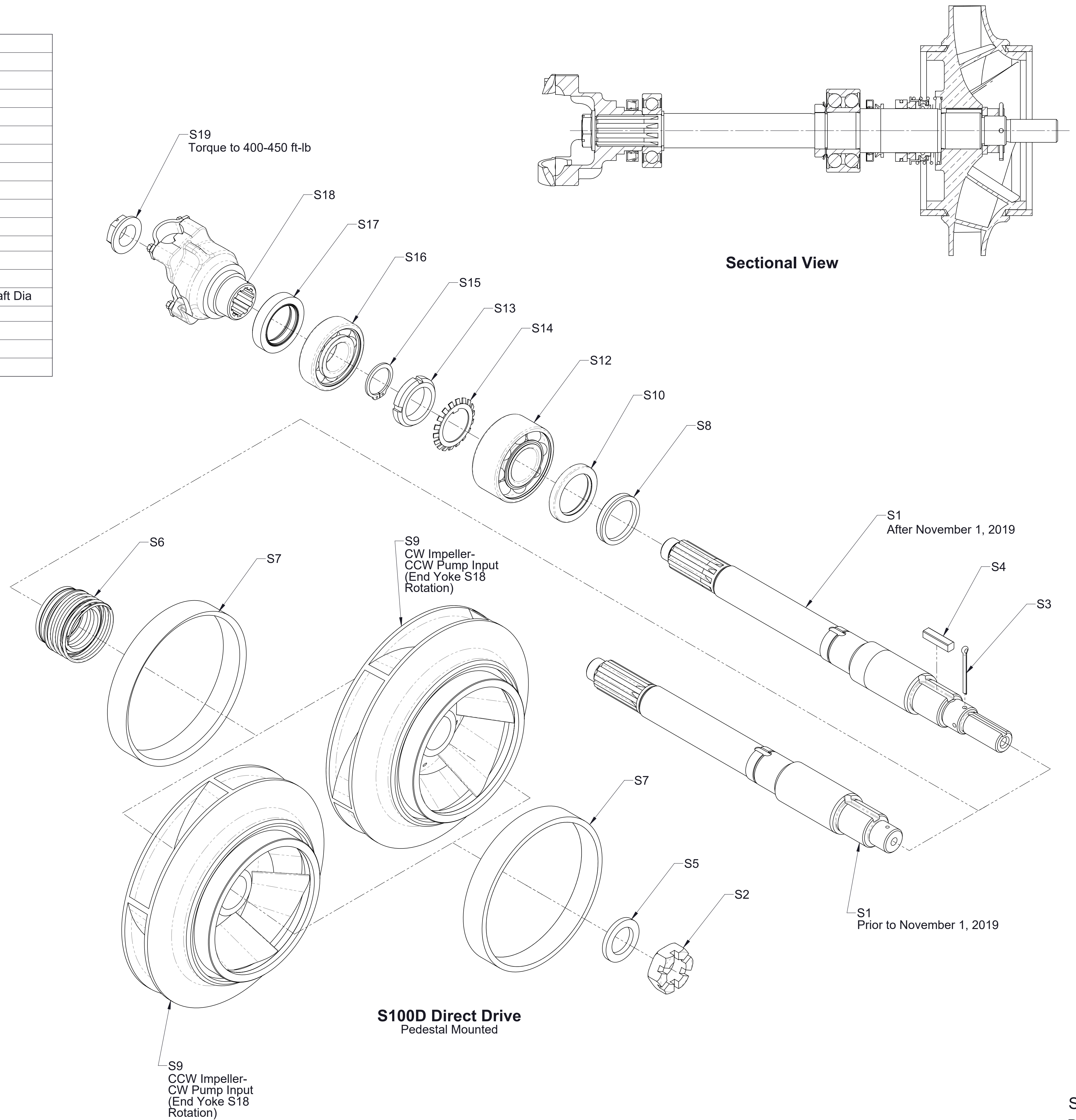

Ref No.	Description
S1	Shaft-Impeller
S2	Nut-Impeller
S3	Pin-Cotter, 5/32 x 2 in
S4	Key-Square, Chamfered, 3/8 x 1-1/2 in
S5	Washer-Flat, 1-1/4 in
S6	Seal-Mechanical
S7	Ring-Wear
S8	V-Ring, Flinger
S9	Impeller
S10	Seal-Oil, 1-7/8 x 2-5/8 in
S11	Key-Square, 1/2 x 1-3/4 in

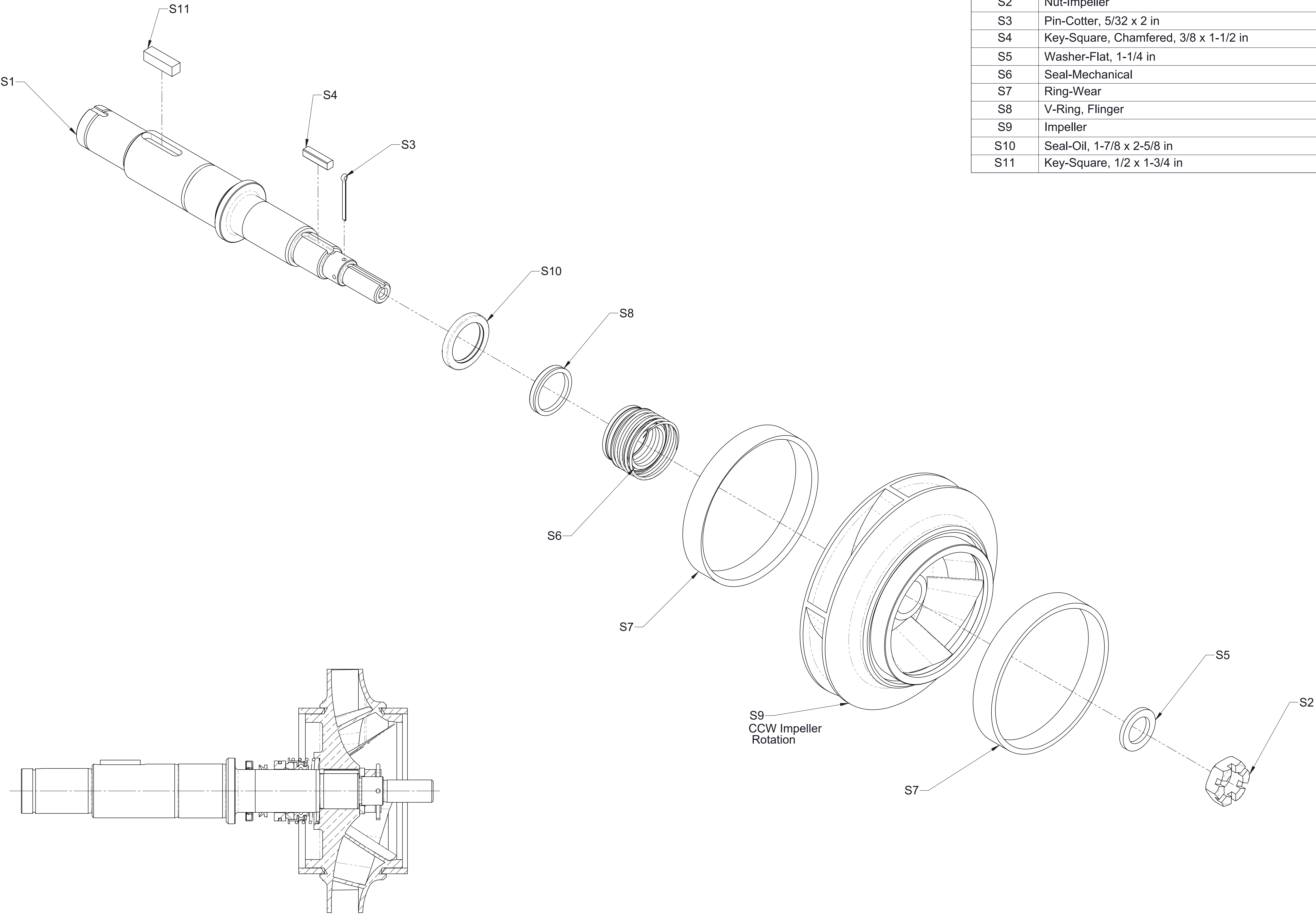

**Section View**

**S100 with QC Transmission**  
 Pump Mounted on Rear (Output Shaft) Side of Transmission

Ref No.	Description
S20	Key-Square, 1/4 x 2 in, SS
S21	Inducer-Impeller
S22	Washer, Nord-Lock, 1/2 in
S23	Screw-Cap, Hex Socket Hd, 1/2-13 x 3-1/2 in, SS

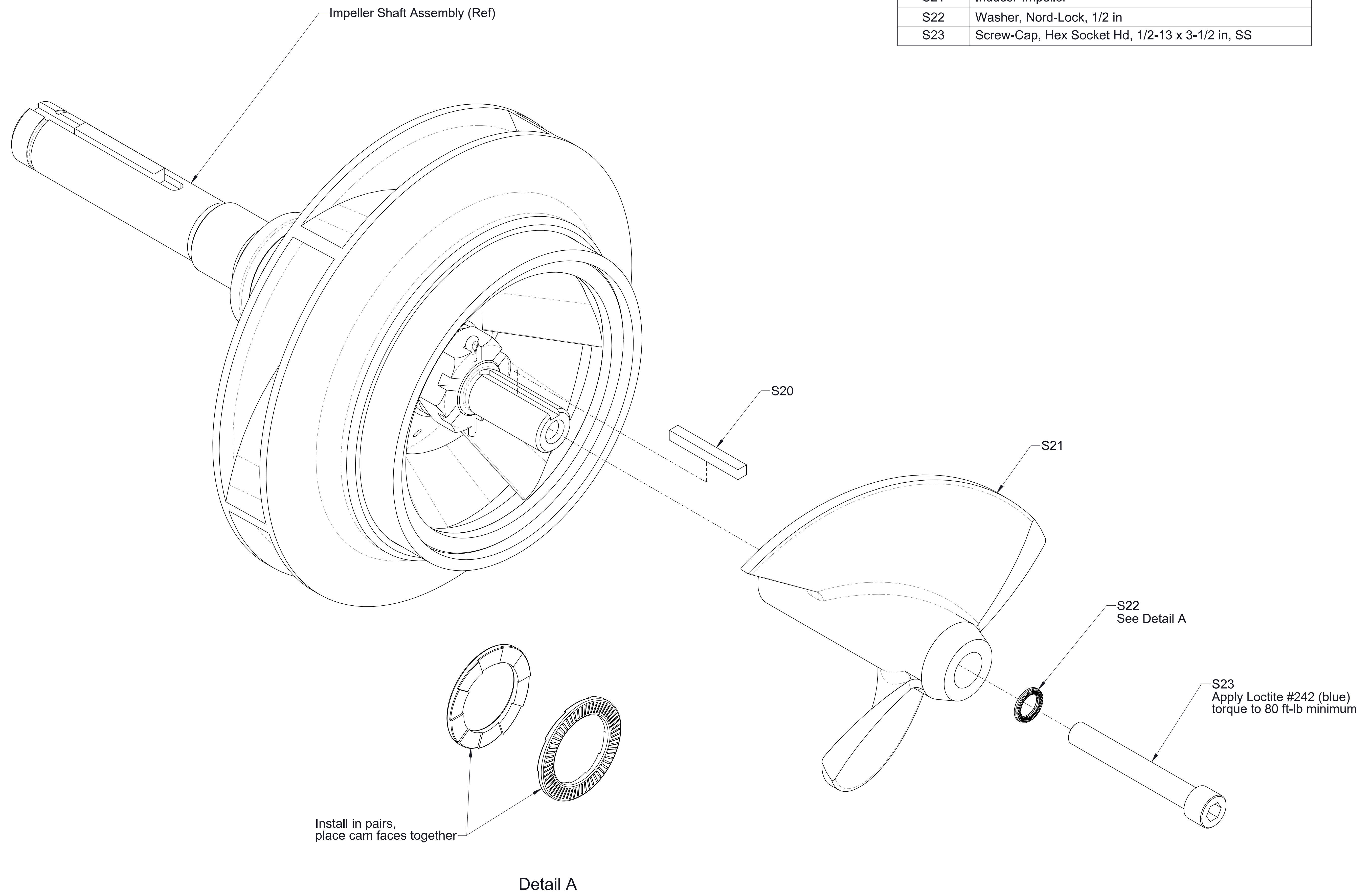

**Impeller Inducer**