



Document Number	Issue Date	Rev. Date
SPL82516	05/01/00	02/08/10

Overheat Protection Manager (OPM) Service Parts List

Index:

Panel Design	Date Built	See Page	
		All CM and CS Series Pump Models	Pump Models Other Than CM and CS
Bezel with Flashing LED	After April 21, 2006	2, 3	8, 9
Die Cast with Fladshing Light Bulb	April 22, 2002 to April 21, 2006	4, 5	10, 11
Die Cast with Separate Flasher	Prior to April 22, 2002	6, 7	-

All CM and CS Series Models Built After 4/21/2006

REF. NO.	DESCRIPTION
1	Thermal Relief Valve
2	Thermal Switch Wire Assembly
8	Control Panel (Includes Ref 15 Mounting Hardware)

REF. NO.	DESCRIPTION
14	Extension Cable
15	Control Panel Mounting Hardware
16	Audible Alarm Assembly

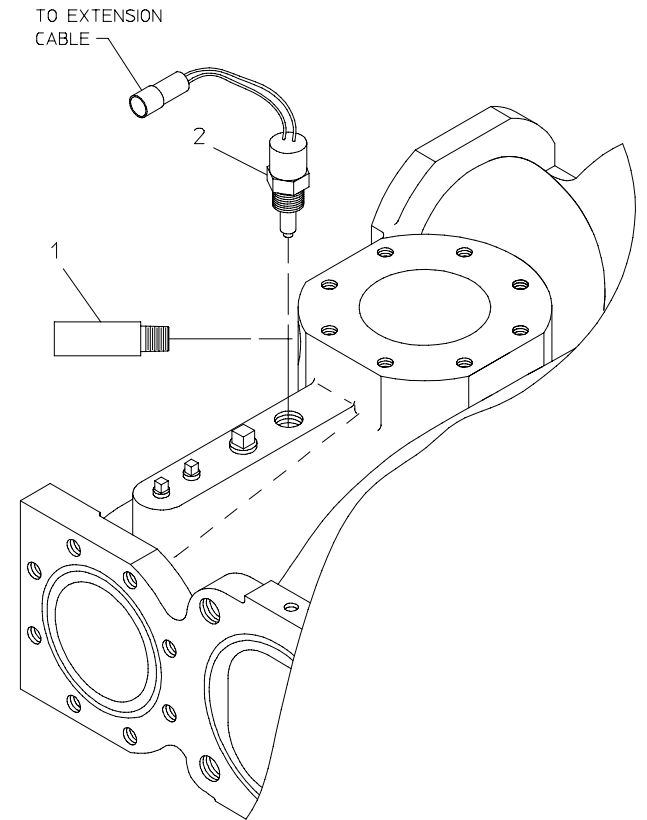
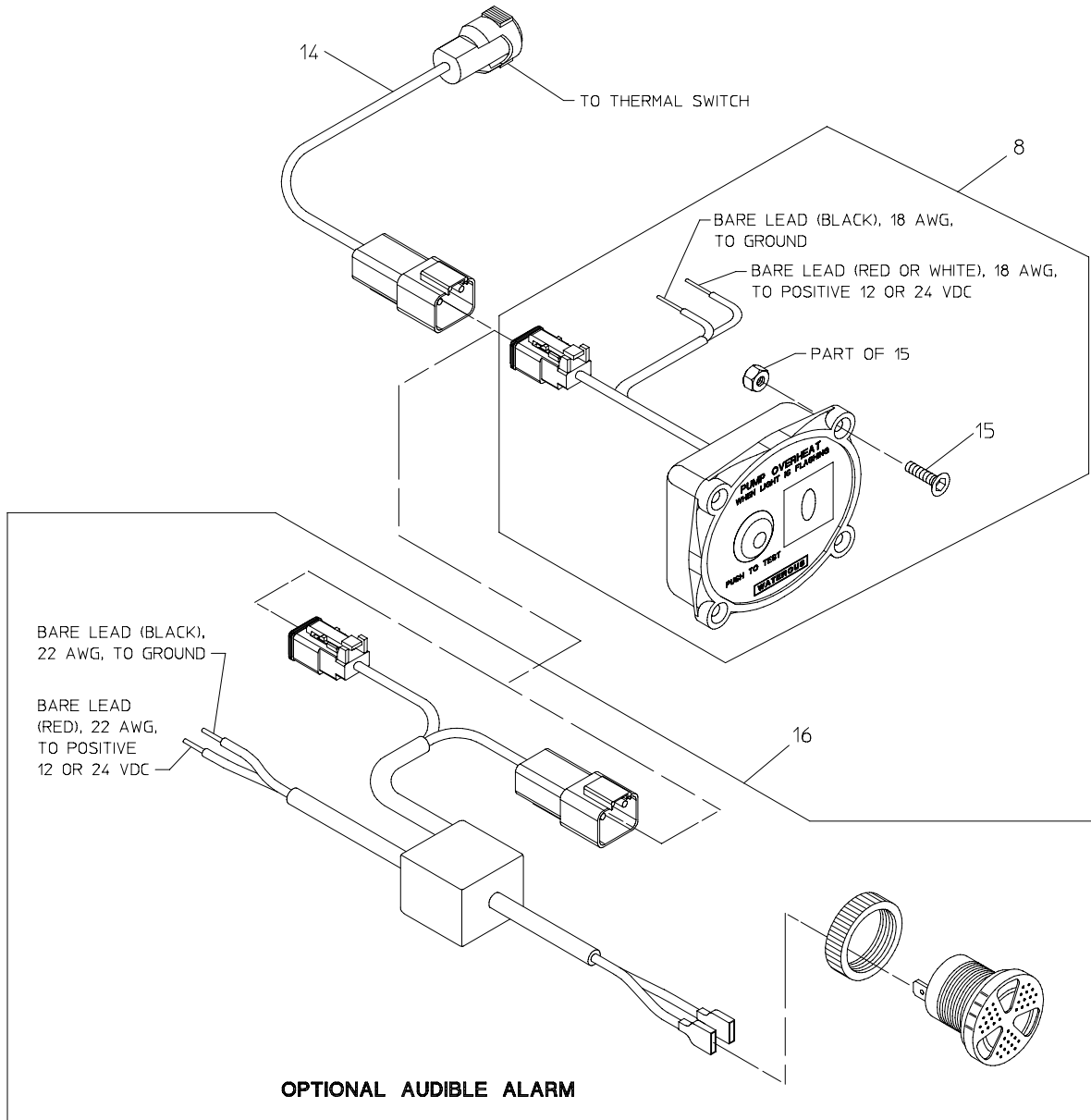

CM & CS MODELS
AFTER APRIL 21, 2006

All CM and CS Series Models Built 4/22/2002 to 4/21/2006

REF. NO.	DESCRIPTION
1	Thermal Relief Valve
2	Thermal Switch Wire Assembly
4	Wire Assembly
5	Push Button Switch Wire Assembly
6	Panel Plate

REF. NO.	DESCRIPTION
7	Warning Light Wire Assembly
8	Panel Wiring Assembly
9	Light Bulb
10	Red Lens Replacement

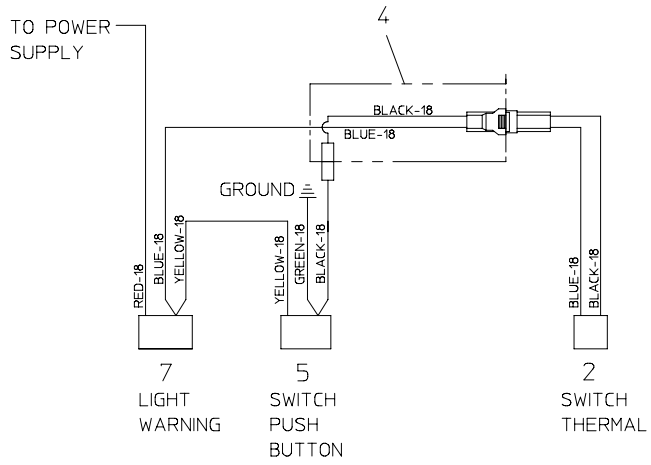

WIRING SCHEMATIC

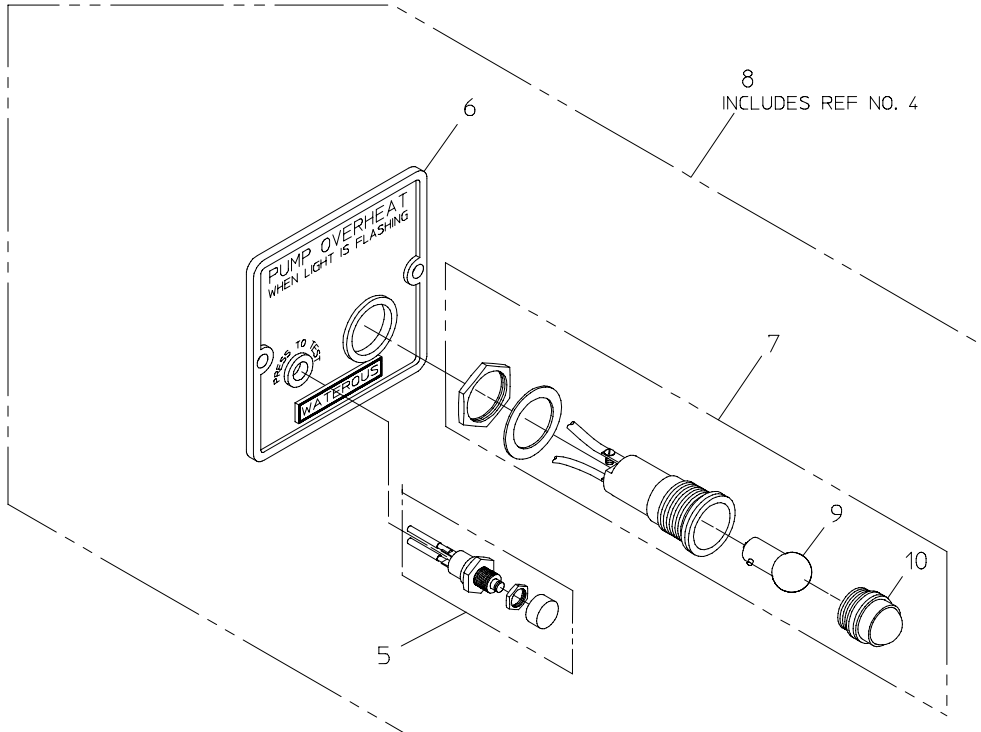
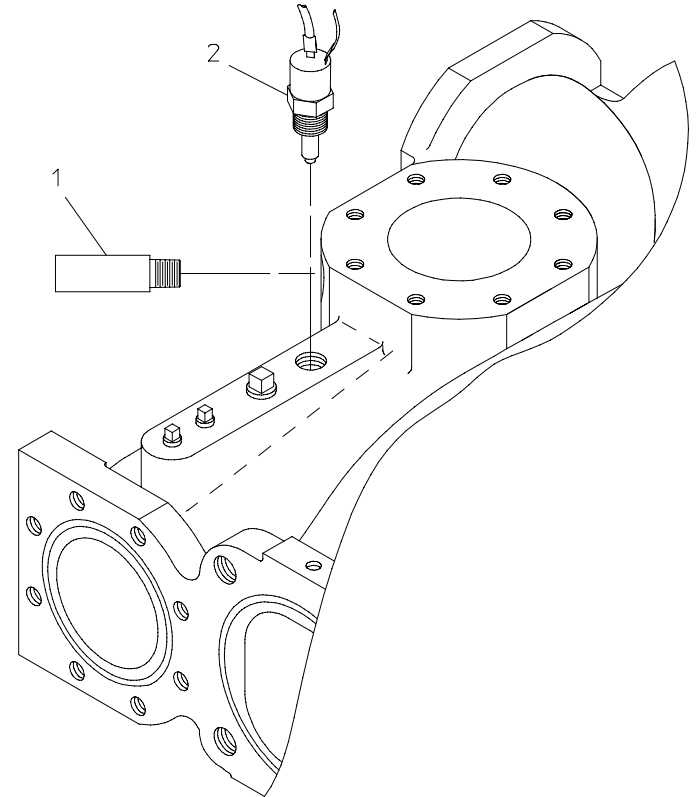

CM & CS MODELS

BETWEEN APRIL 22, 2002 AND APRIL 21, 2006

All CM and CS Series Models Built Prior to 4/22/2002

REF. NO.	DESCRIPTION
1	Thermal Relief Valve
2	Thermal Switch Wire Assembly
3	Flasher
4	Wire Assembly
5	Push Button Switch Wire Assembly
6	Panel Plate

REF. NO.	DESCRIPTION
7	Warning Light Wire Assembly
8	Panel Wiring Assembly
9	Light Bulb (Replacement No. 1891)
10	Red Lens Replacement

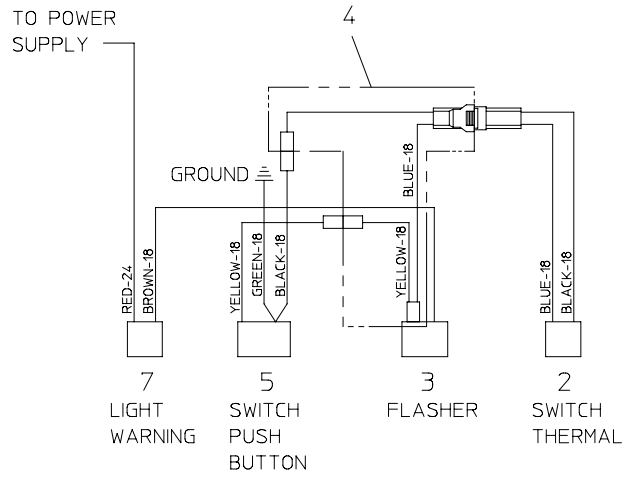

WIRING SCHEMATIC

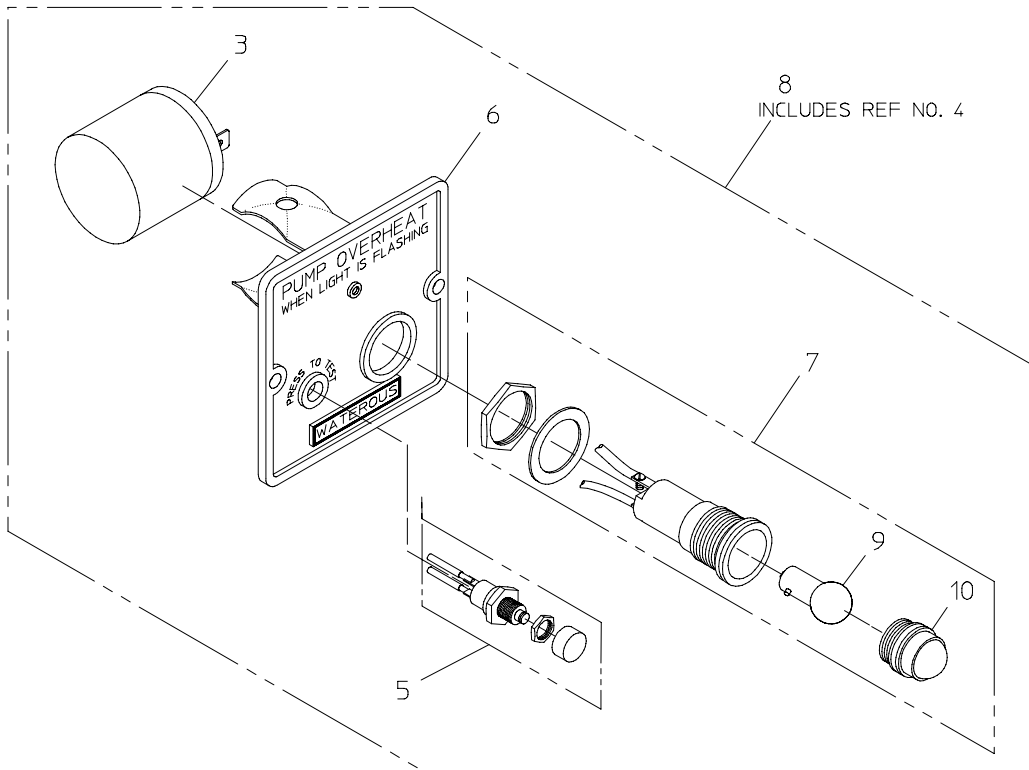
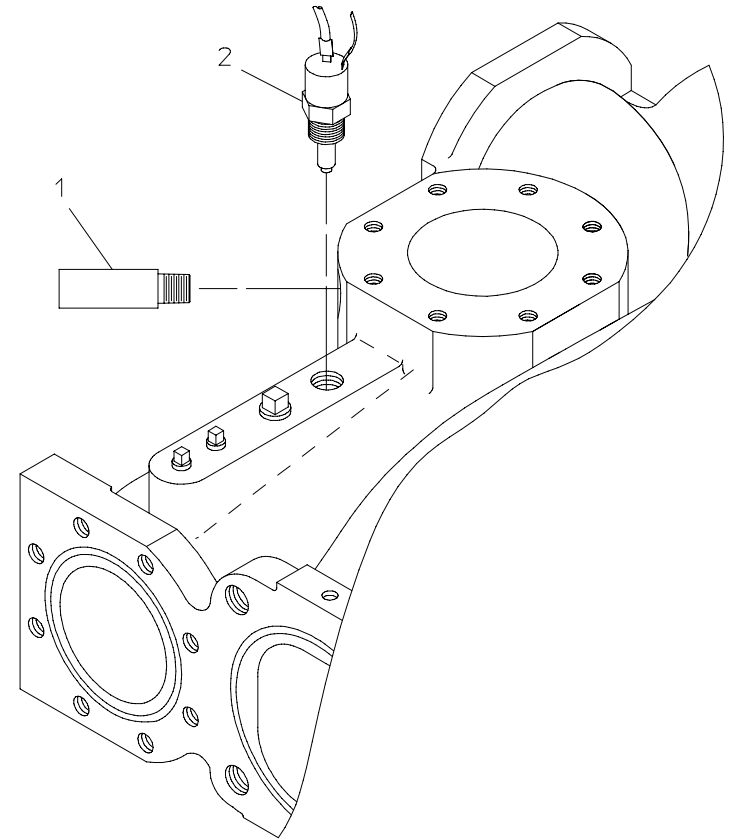

CM & CS MODELS
PRIOR TO APRIL 22, 2002

Pump Models Other Than CM and CS Built After 4/21/2006

REF. NO.	DESCRIPTION
1	Thermal Relief Valve
2	Thermal Switch Wire Assembly
8	Control Panel (Includes Ref 15 Mounting Hardware)
11	Flange

REF. NO.	DESCRIPTION
12	Hex Hd Screw, 7/16-14 x 1 in.
13	O-ring, 3-1/2 x 3-3/4 in.
14	Extension Cable
15	Control Panel Mounting Hardware
16	Audible Alarm Assembly

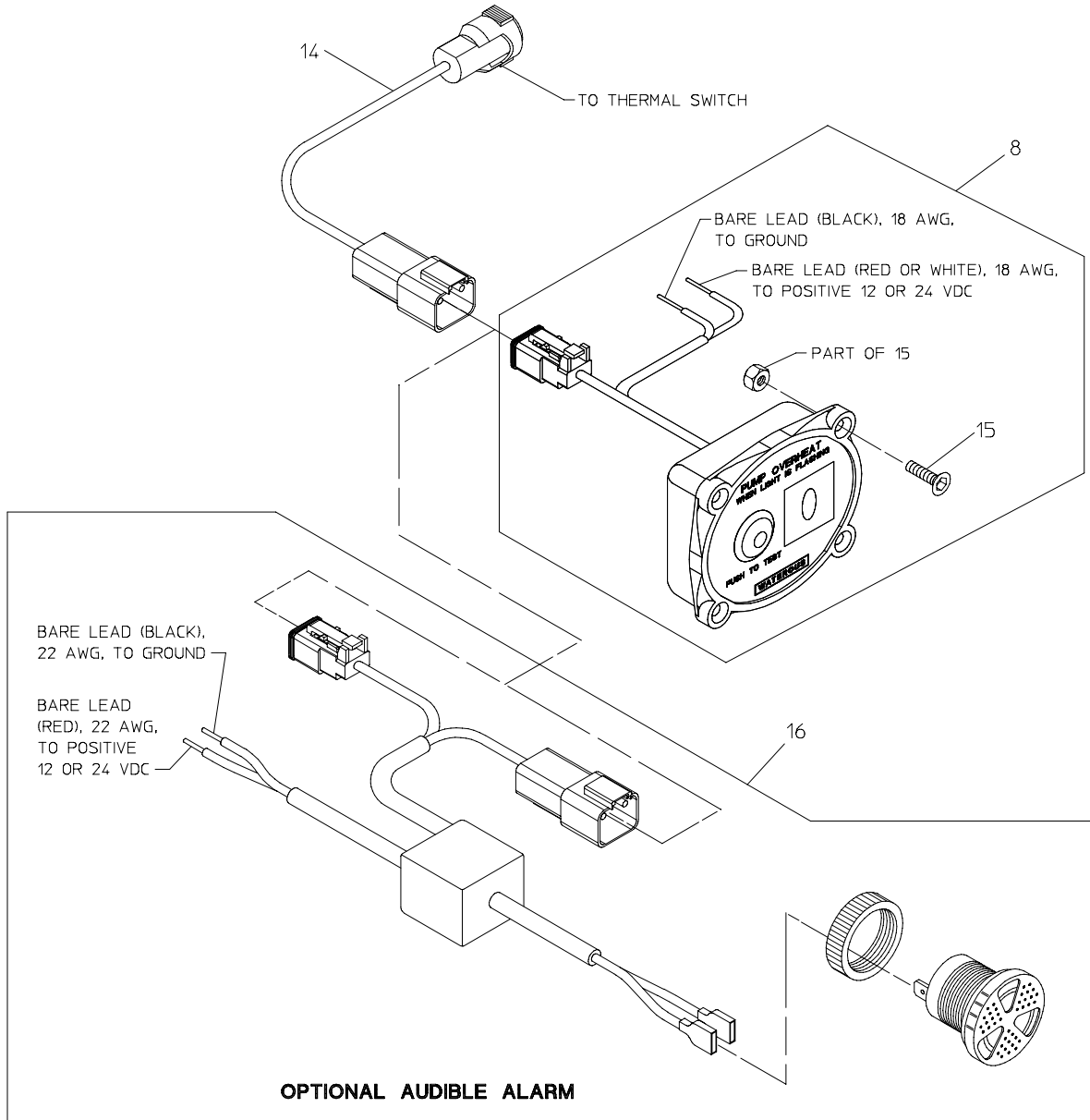

MOUNTED NEAR PUMP DISCHARGE BY OEM

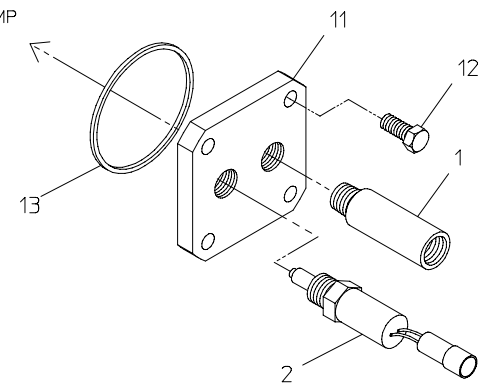

PUMP MODELS OTHER THAN CM & CS

AFTER APRIL 21, 2006

Pump Models Other Than CM and CS Built Prior to 4/21/2006

REF. NO.	DESCRIPTION
1	Thermal Relief Valve
2	Thermal Switch Wire Assembly
4	Wire Assembly
5	Push Button Switch Wire Assembly
6	Panel Plate
7	Warning Light Wire Assembly

REF. NO.	DESCRIPTION
8	Panel Wiring Assembly
9	Light Bulb
10	Red Lens Replacement
11	Flange
12	Hex Hd Screw, 7/16-14 x 1 in.
13	O-ring, 3-1/2 x 3-3/4 in.

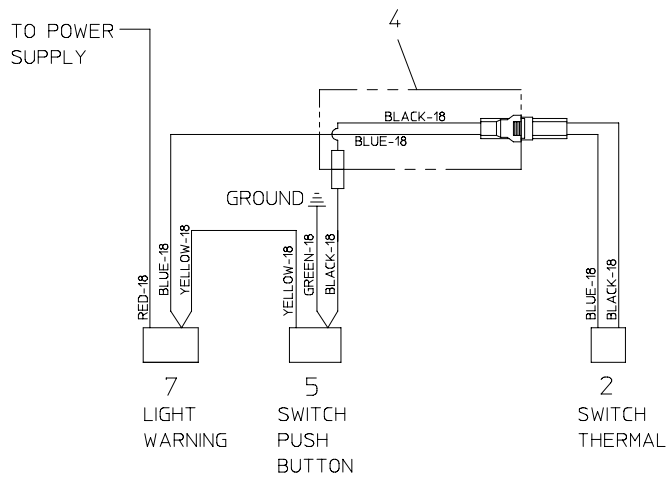

WIRING SCHEMATIC

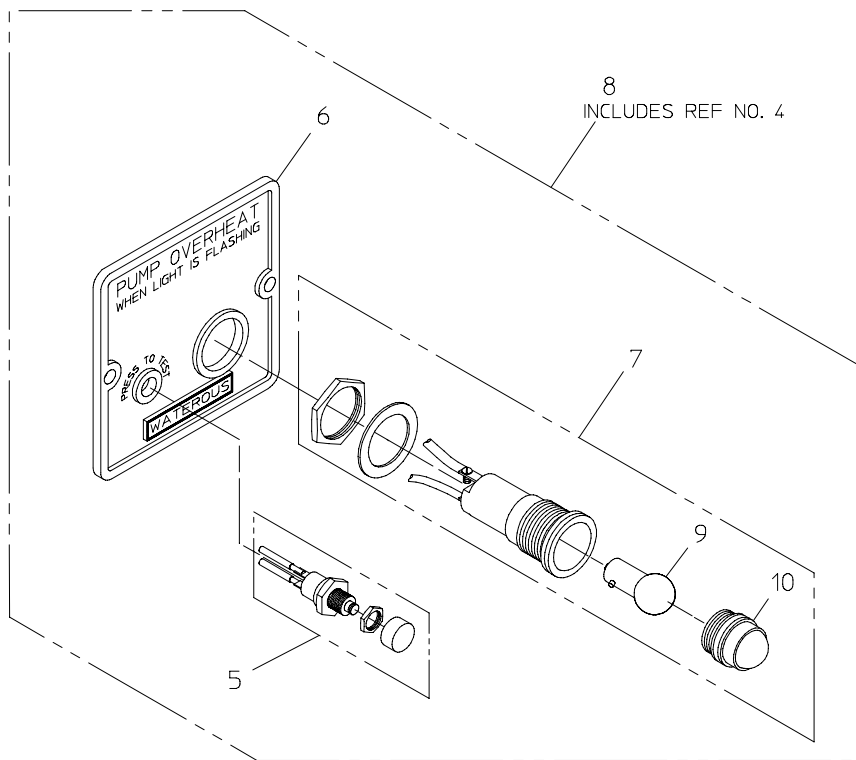

MOUNTED NEAR PUMP DISCHARGE BY OEM

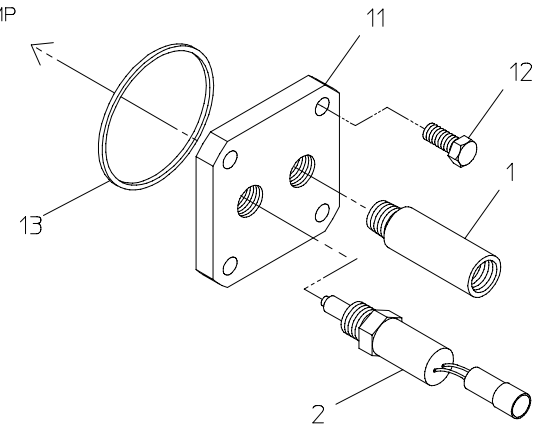

PUMP MODELS OTHER THAN CM & CS

PRIOR TO APRIL 21, 2006