

## CZU Series Pump Impeller Shaft Service Parts List

Index:

View	See Page
Exploded View	2, 3
Cross Section View	4, 5

## Exploded View

Ref No.	Description
S1	Impeller (Includes Collar)
S2	Impeller Shaft
S3	Wear Ring (Available in Standard or 0.025, 0.050 and 0.075 in. Undersize)
S4	Impeller Nut
S5	Bearing Spacer
S6	Oil Seal Sleeve
S7	Impeller Washer
S8	Shaft Nut
S9	Mechanical Seal Kit (Includes S9, S17, S19, S20, S21) (Also includes B9 O-ring from Body Assembly)

Ref No.	Description
S11	Oil Seal, 2-1/2 x 3-1/4 x 7/16 in.
S12	Oil Seal, 2-1/4 x 3-1/8 x 3/8 in.
S13	Flat Washer, 1 in.
S15	Ball Bearing, Double Row
S16	Ball Bearing, Single Row
S17	Cotter Pin, 5/32 x 2 in.
S19	O-ring, 3 x 3-3/8 in.
S20	O-ring, 1-5/16 x 1-9/16 in.
S21	O-ring, 2-1/4 x 2-3/8 in.

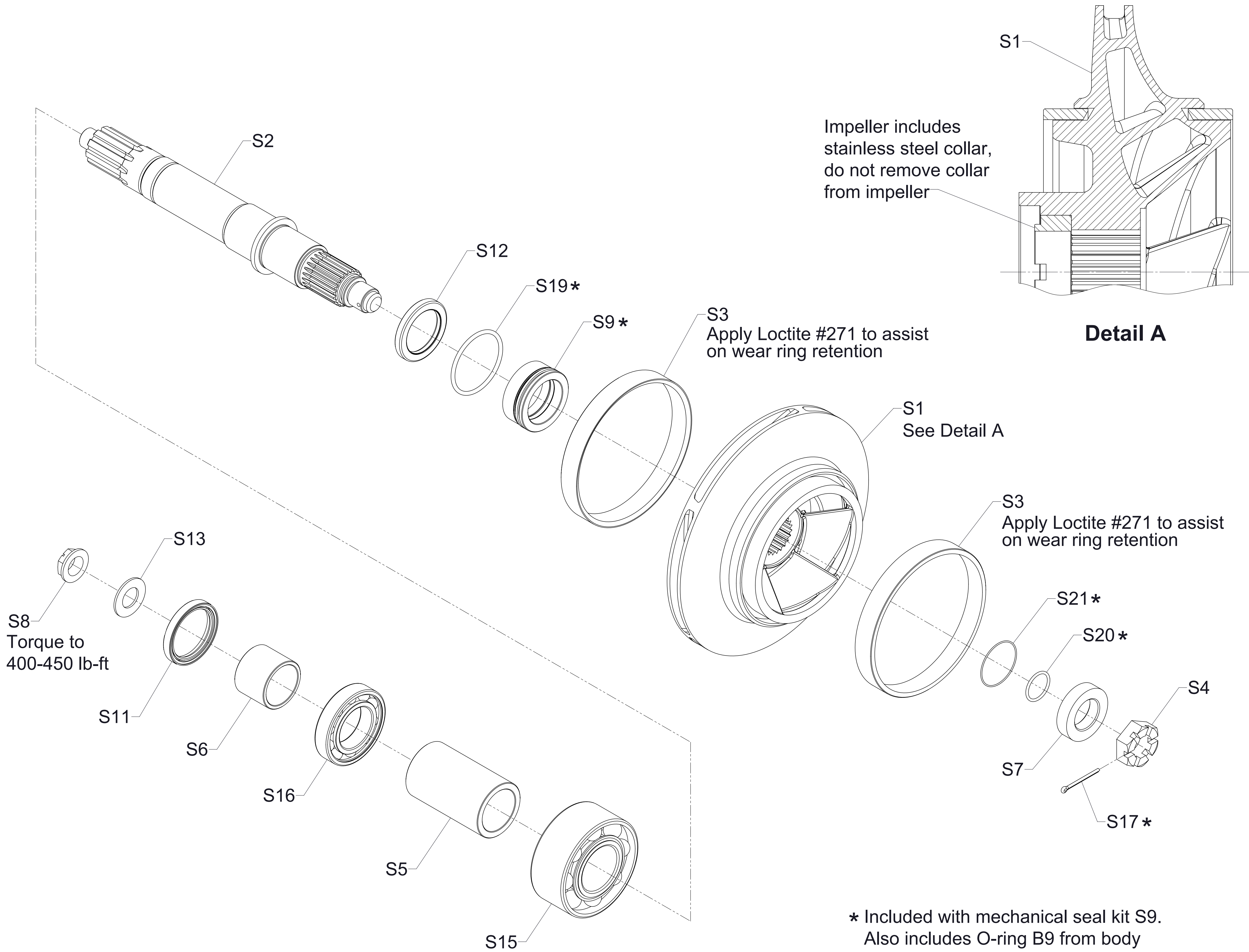

**Exploded View**

## Cross Section View

Ref No.	Description
S1	Impeller (Includes Collar)
S2	Impeller Shaft
S3	Wear Ring (Available in Standard or 0.025, 0.050 and 0.075 in. Undersize)
S4	Impeller Nut
S5	Bearing Spacer
S6	Oil Seal Sleeve
S7	Impeller Washer
S8	Shaft Nut
S9	Mechanical Seal Kit (Includes S9, S17, S19, S20, S21) (Also includes B9 O-ring from Body Assembly)

Ref No.	Description
S11	Oil Seal, 2-1/2 x 3-1/4 x 7/16 in.
S12	Oil Seal, 2-1/4 x 3-1/8 x 3/8 in.
S13	Flat Washer, 1 in.
S15	Ball Bearing, Double Row
S16	Ball Bearing, Single Row
S17	Cotter Pin, 5/32 x 2 in.
S19	O-ring, 3 x 3-3/8 in.
S20	O-ring, 1-5/16 x 1-9/16 in.
S21	O-ring, 2-1/4 x 2-3/8 in.

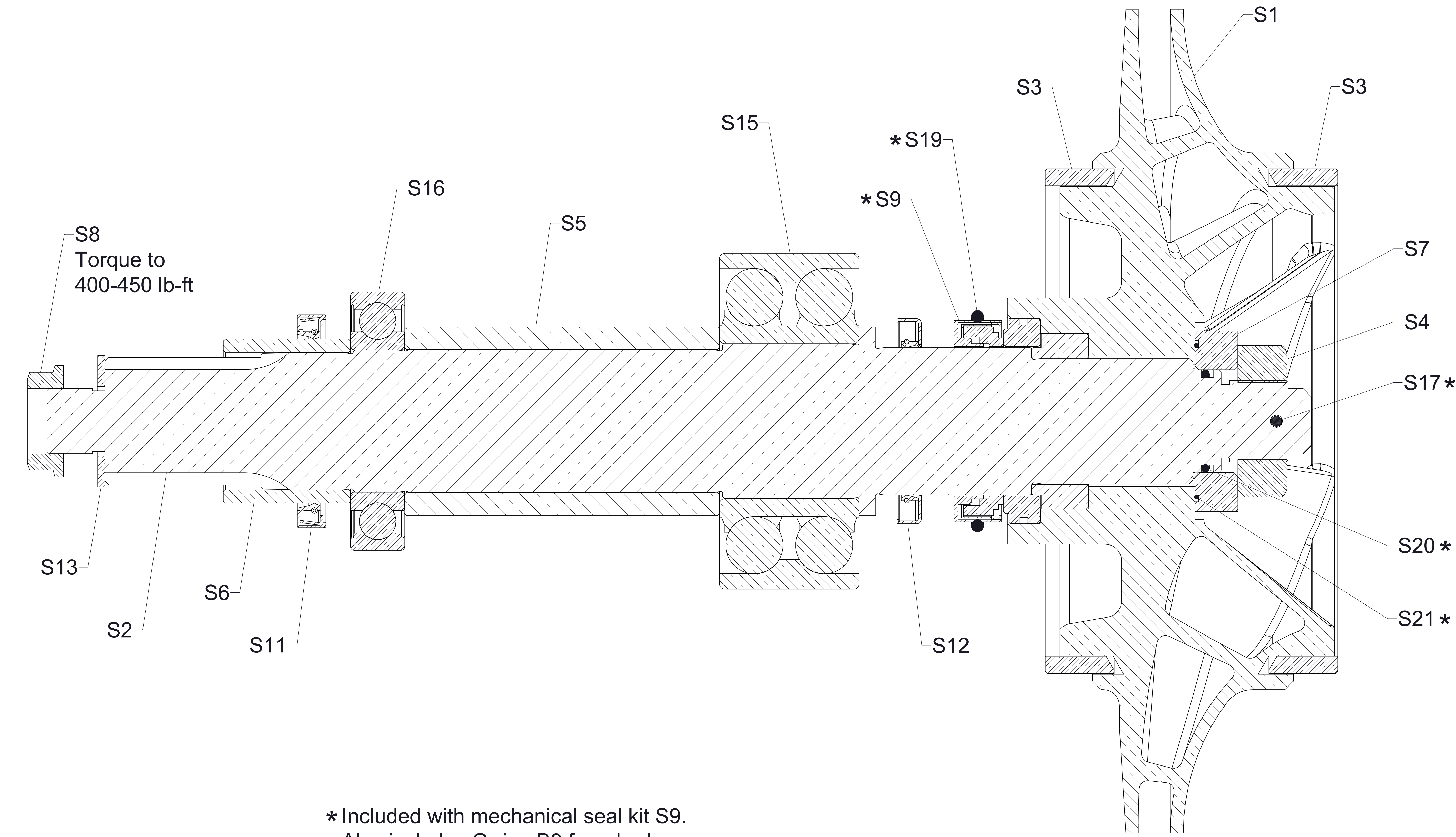

\* Included with mechanical seal kit S9.  
 Also includes O-ring B9 from body  
 assembly

Cross Section View