



Document Number	Issue Date	Rev. Date
SPL82615	10/15/02	8/14/17

Electric Discharge Valve Assembly with Rotary Actuator, 2-1/2 STD Service Parts List

Index:

Components	See Page
2-1/2 in. Standard Electric Ball Valve	2, 3
Electric Rotary Actuator	4, 5
Cables and Panel Components	6, 7
Available Repair Subassemblies	8, 9

2-1/2 in. Standard Electric Ball Valve

REF. NO.	DESCRIPTION
4	Spring Pin, 3/16 in.
33	Valve Body
34	Upper Stem Bushing
35	O-ring, 2-1/8 x 2-3/8 in.
36	O-ring, 3/4 x 15/16 in.
37	Ball Valve
38	O-ring, 9/16 x 3/4 in.
39	Lower Stem Bushing
40	Pipe Plug, 1/4 in.
41	O-ring, 3-3/8 x 3-5/8 in.
42	Retainer Seal
43	Valve Seal
44	Wave Spring

REF. NO.	DESCRIPTION
45	O-ring, 2-1/2 x 2-3/4 in.
46	Socket Flat Hd Screw, 7/16-14 x 3/4 in.
47	Pipe Plug, 3/4 in.
60	Hex Hd Screw, 7/16-14 x 1 in. (See Note 1)
61	Hex Hd Screw, 7/16-20 x 1-1/2 in.
62	Mounting Flange
63	O-ring, 2-3/4 x 3 in.
64	Hex Nut, 7/16-20 (Used Only With 61)
65	Pipe Nipple, 2-1/2 x 10 in. (See Note 2)
66	Hose Adapter (See Note 2)
67	Hose Nipple (See Note 2)
72	O-ring and Gasket Repair Kit

Notes:

1. Ref. no. 60, Hex Hd Screw 7/16-14 x 1 in. used instead of ref. no. 61, Hex Hd Screw 7/16-20 x 1-1/2 in. when discharge flange has tapped mounting holes.
2. Ref. no. 65, 66 and 67 may have been furnished by either Waterous or original equipment manufacturer.

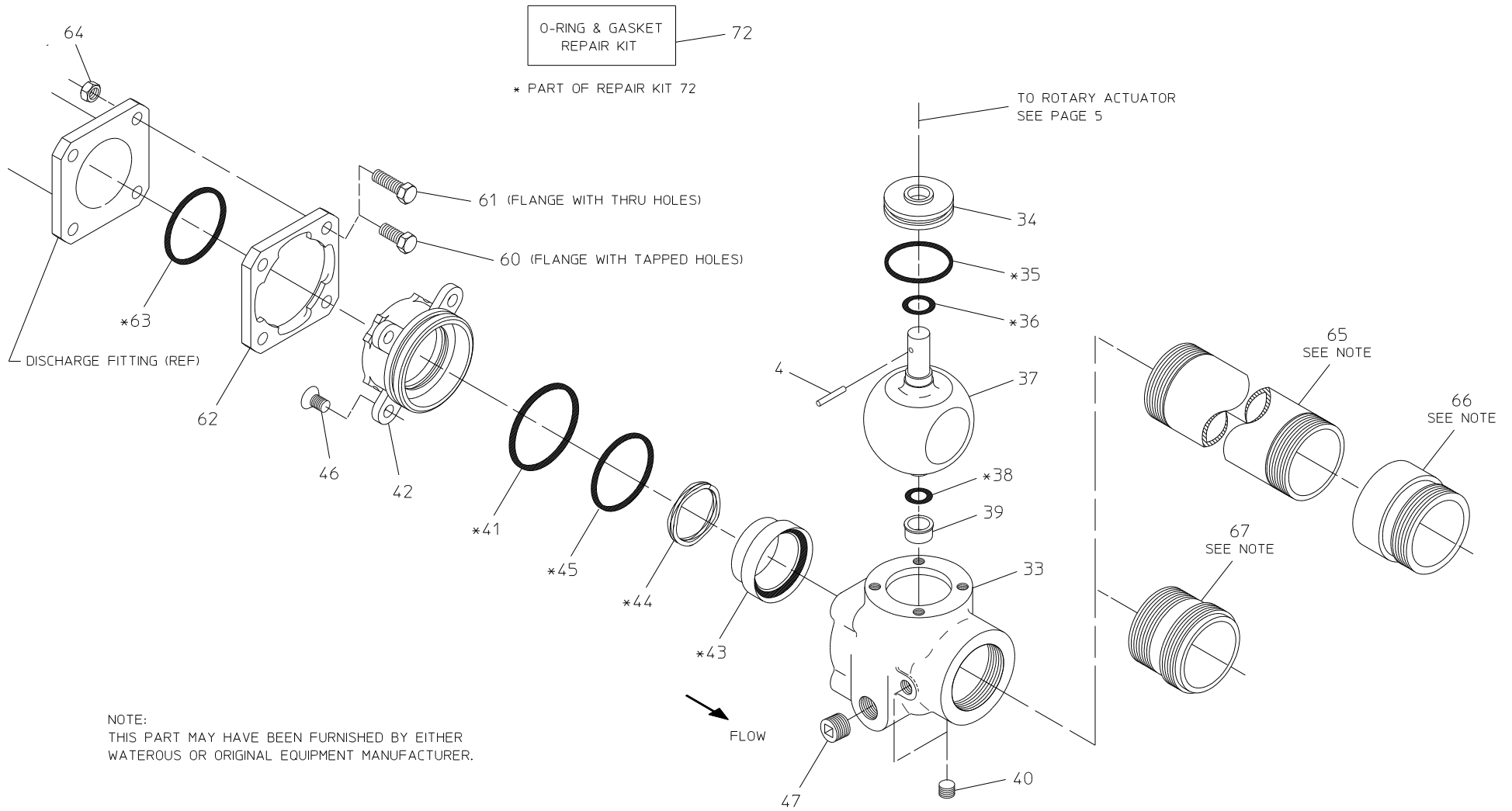

2-1/2 IN. STANDARD ELECTRIC BALL VALVE

Electric Rotary Actuator

REF. NO.	DESCRIPTION
1	Mounting Bracket
2	Hex Hd Screw, 1/4-20 x 5/8 in.
3	Lock Washer, 1/4 in.
5	Extension Shaft
6	Worm Gear Housing Assembly (Includes Flanges Bearing 9, Sleeve Bearing 12 and O-ring 13)
7	Rubber Plug
8	O-ring, 1 x 1-1/4 in.
9	Flanged Bearing, 1-1/4 x 1-1/2 in.
10	Worm Gear Sector
11	Key, 3/16 x 1-1/4 in.
12	Sleeve Bearing, 1/2 x 5/8 in.
13	O-ring, 1/2 x 5/8 in.
14	Worm Gear
15	Spirol Pin, 1/8 x 3/4 in.
16	Housing Cover Assembly (Includes Flanged Bearing 9)

REF. NO.	DESCRIPTION
17	Socket Hd Screw, 1/4-20 x 5/8 in.
19	Socket Hd Screw, 8-32 x 1/2 in.
21	Socket Hd Screw, 8-32 x 7/8 in.
22	Lock Washer, #8
25	Gear Motor
27	Retaining Ring
30	Limit Disc
31	Hex Hd Screw, 3/8-16 x 5/8 in.
32	Lock Washer, 3/8 in.
48	Actuator Gasket
53	Rotary Switch Assembly (Prior to November 6, 2006)
53	Rotary Encoder (After November 6, 2006)
54	Gear Motor Gasket
72	O-ring and Gasket Repair Kit
85	Motor Replacement Kit

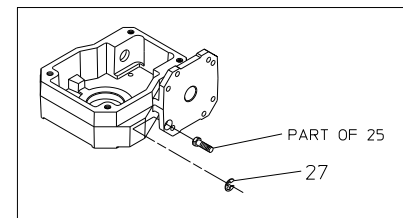
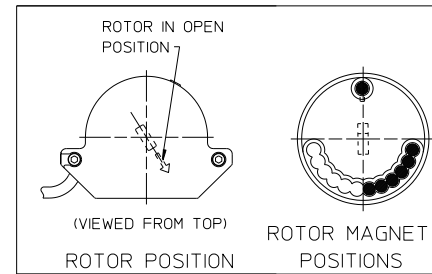
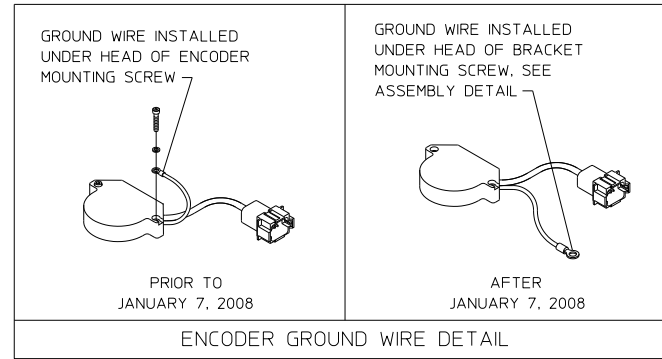
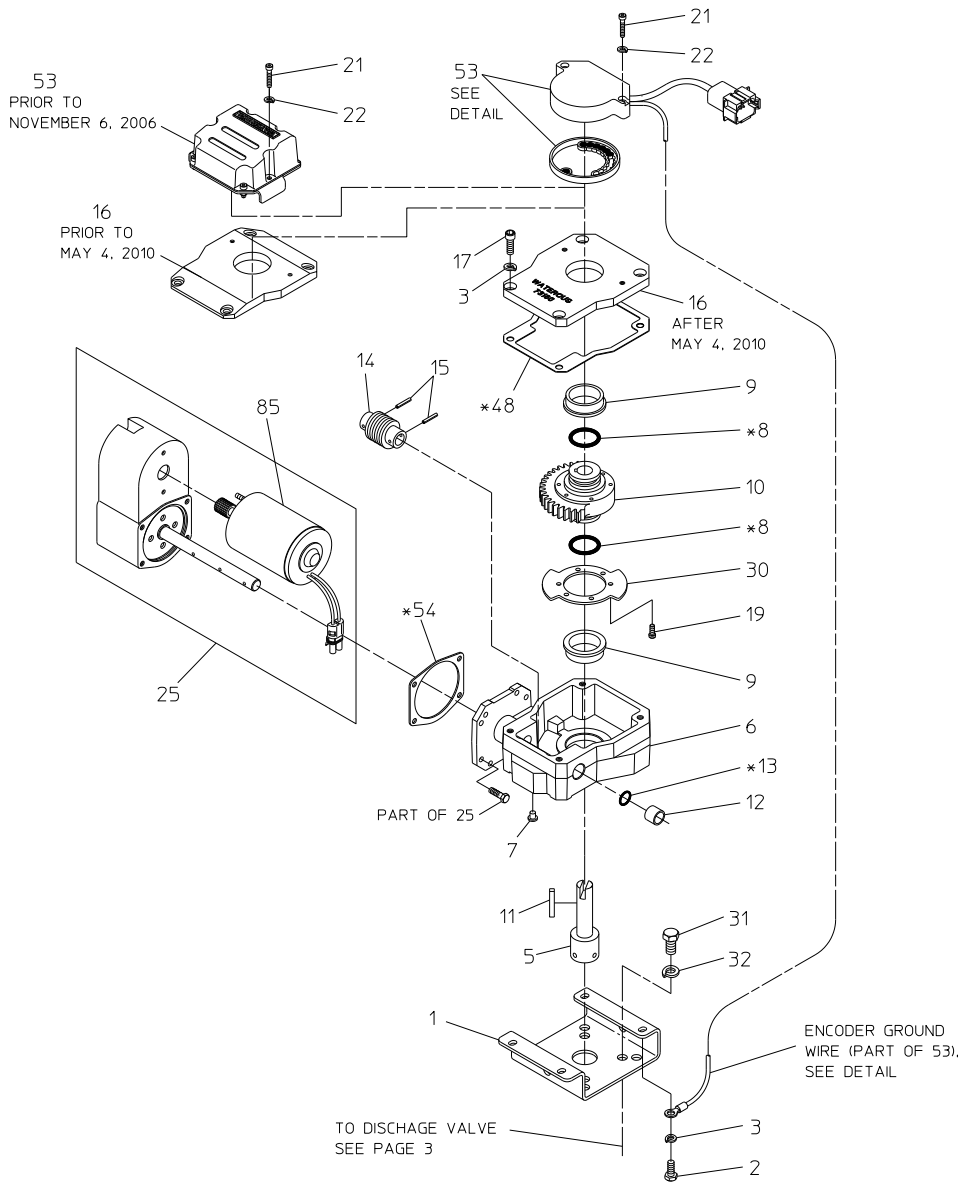

VERTICAL MOTOR
MOUNT ONLY

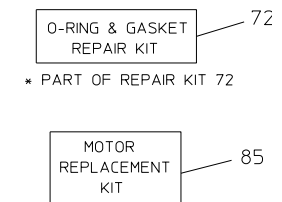

ELECTRIC ROTARY ACTUATOR

Cable and Panel Components

REF. NO.	DESCRIPTION
24	Adapter Nut
26	Spirol Pin, 1/8 x 3/4 in.
69	LED Panel Wiring Assembly
70	Switch Extension Wire Assembly

REF. NO.	DESCRIPTION
71	Motor Extension Wire Assembly
83	Socket Hd Screw, 6-32 x 3/4 in. (Prior to November 6, 2006)
83	Control Panel Mounting Hardware (Includes (4) Socket Hd Screws, #6-32 x 3/4 and (4) Nylok Nuts, #6-32) (After November 6, 2006)
84	Nylok Nut, #6-32 (Prior to November 6, 2006)

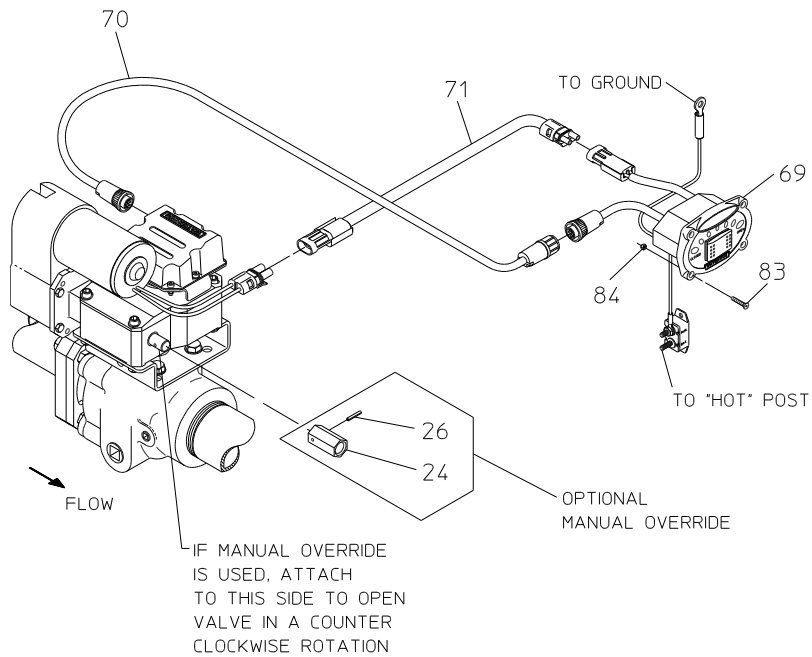

**VALVES BUILT PRIOR TO
NOVEMBER 6, 2006**

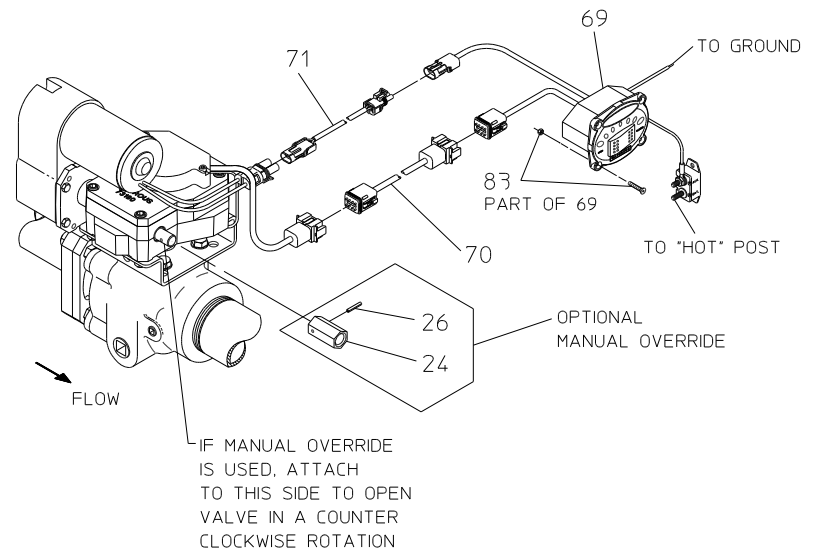

**VALVES BUILT AFTER
NOVEMBER 6, 2006**

CABLES AND PANEL COMPONENTS

Available Repair Subassemblies

REF. NO.	DESCRIPTION
86	Actuator Subassembly

REF. NO.	DESCRIPTION
87	Valve and Actuator Subassembly

86

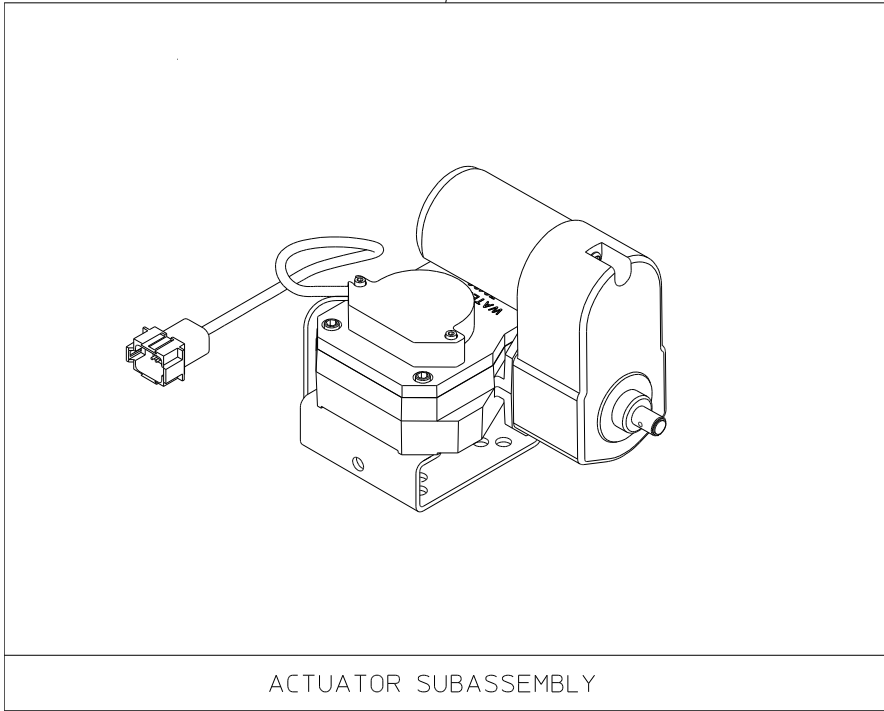

87

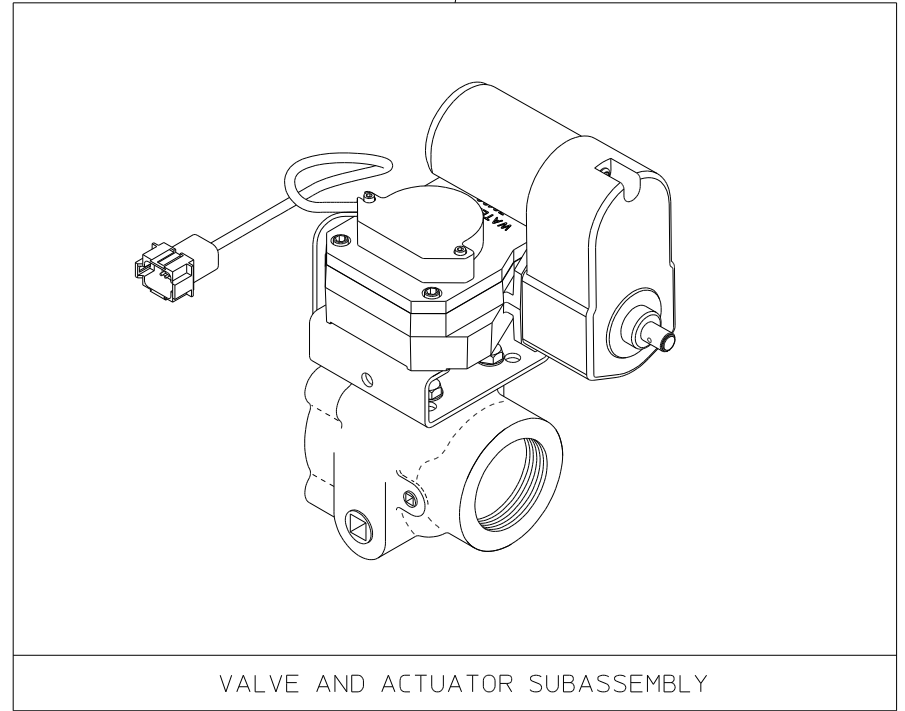

AVAILABLE REPAIR SUBASSEMBLIES