



Document Number	Issue Date	Rev. Date
SPL82654	02/03/03	07/19/12

Eclipse ES™ Compressor and Drive with Electric Auto-Sync Service Parts List

Index:

Product		See Pages			
Type	Model <i>(See Serial Plate)</i>	Compressor Mounting	Clutch, Sprocket and Belt Installation	Belt Cover Installation	Oil Cooler, Sump and Panel Components
S100 Series Pumps	S100C10C, S100C20C, S100C10D, S100C20D, S100C10E, S100C20E, S100C10F, S100C20F	2, 3 (C10 Models) 4, 5 (C20 Models)	8, 9	10, 11	20, 21
CXV Series Pumps	CXVC10C, CXVC20C, CXVC10D, CXVC20D, CXVC10E, CXVC20E, CXVC10F, CXVC20F	6, 7			
CXN Series Pumps	CXNC10C, CXNC20C, CXNC10D, CXNC20D, CXNC10E, CXNC20E, CXNC10F, CXNC20F				
CXS Series Pumps	CXSC10C, CXSC20C, CXSC10D, CXSC20D, CXSC10E, CXSC20E, CXSC10F, CXSC20F				
TC10 Series P.T.O.'s	TC10B TC10C TC10D TC10E TC10F	12, 13	16, 17	18, 19	
TC20 Series P.T.O.'s	TC20B TC20C TC20D TC20E, TC20F	14, 15			

Compressor Mounting, S100C10 Series Pumps

REF. NO.	DESCRIPTION
1	Lock Washer, 10 mm
11	SPDT Relay
16	Lock Washer, 12 mm
17	Hex Hd Screw, M12 x 1.75 x 25 mm
24	Lock Washer, 8 mm

REF. NO.	DESCRIPTION
38	Hex Hd Screw, M10 x 1.5 x 20 mm
40	Air Compressor (New)
49	Compressor Bracket
51	Hex Hd Screw, M8 x 1.25 x 30 mm
66	Air Compressor (Re-Manufactured)

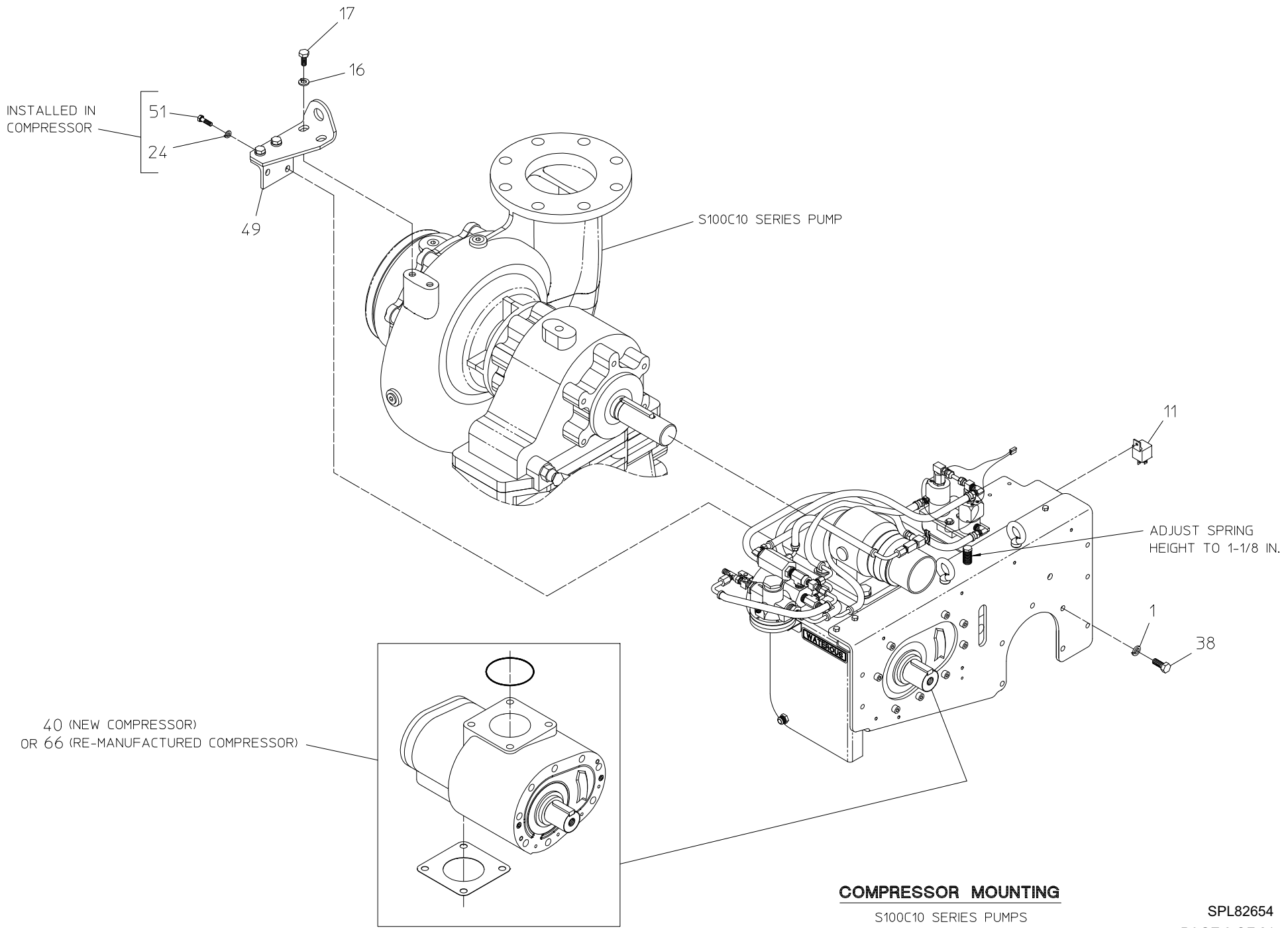

COMPRESSOR MOUNTING

S100C10 SERIES PUMPS

Compressor Mounting, S100C20 Series Pumps

REF. NO.	DESCRIPTION
1	Lock Washer, 3/8 in.
11	SPDT Relay
16	Lock Washer, 12 mm
17	Hex Hd Screw, M12 x 1.75 x 25 mm
24	Lock Washer, 8 mm

REF. NO.	DESCRIPTION
38	Hex Hd Screw, 3/8-16 x 1 in.
40	Air Compressor (New)
49	Compressor Bracket
51	Hex Hd Screw, M8 x 1.25 x 30 mm
66	Air Compressor (Re-Manufactured)

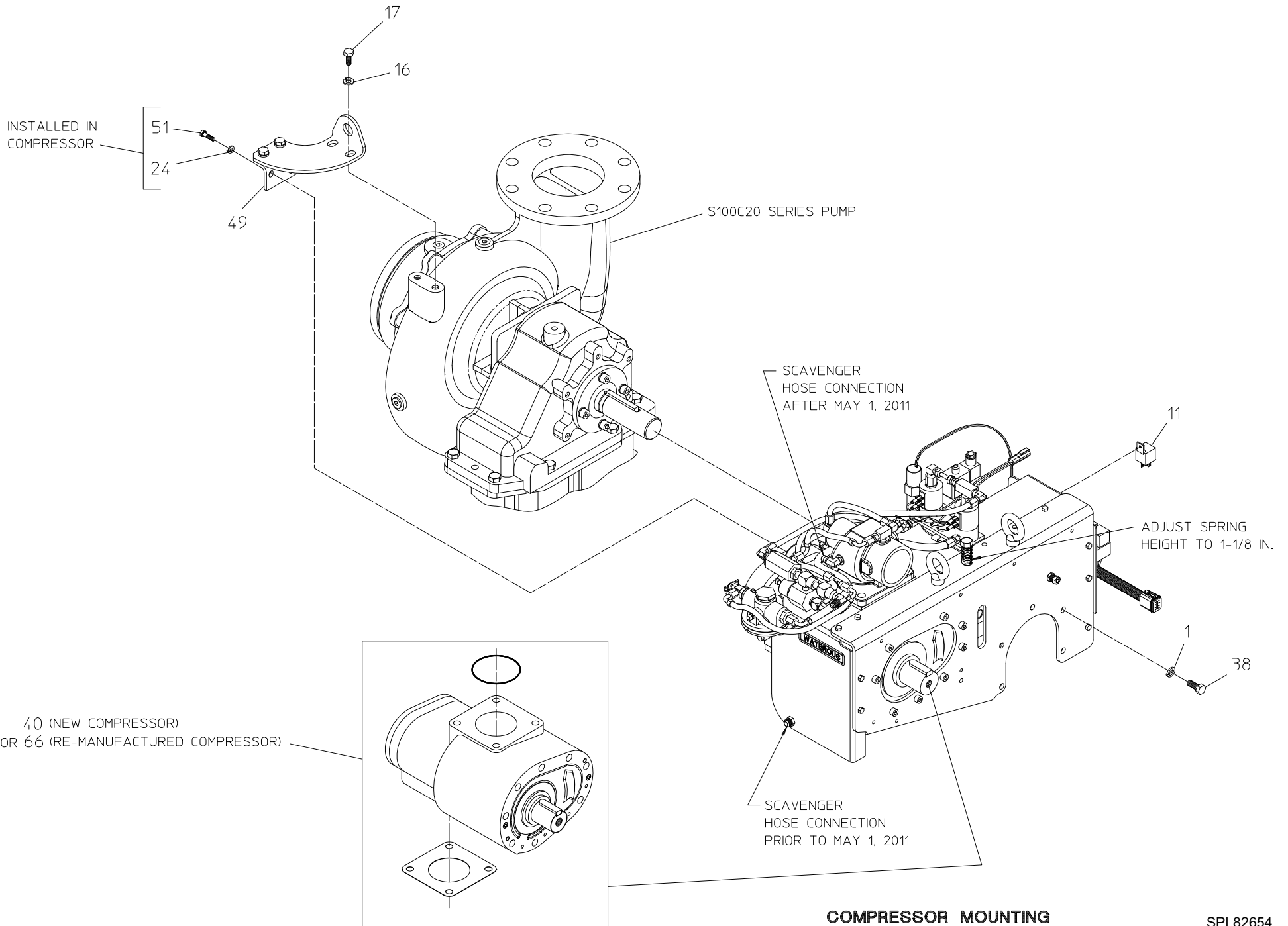

COMPRESSOR MOUNTING

S100C20 SERIES PUMPS

Compressor Mounting, CX Series Pumps

REF. NO.	DESCRIPTION
1	Lock Washer, 10 mm (C10 Series)
	Lock Washer, 3/8 in. (C20 Series)
11	SPDT Relay
24	Lock Washer, 8 mm
38	Hex Hd Screw, M10 x 1.5 x 20 mm (C10 Series)
	Hex Hd Screw, 3-8/16 x 1 in. (C20 Series)

REF. NO.	DESCRIPTION
40	Air Compressor (New)
49	Compressor Bracket
50	Hex Hd Screw, 1/2-13 x 1-1/2 in.
51	Hex Hd Screw, M8 x 1.25 x 30 mm
66	Air Compressor (Re-Manufactured)

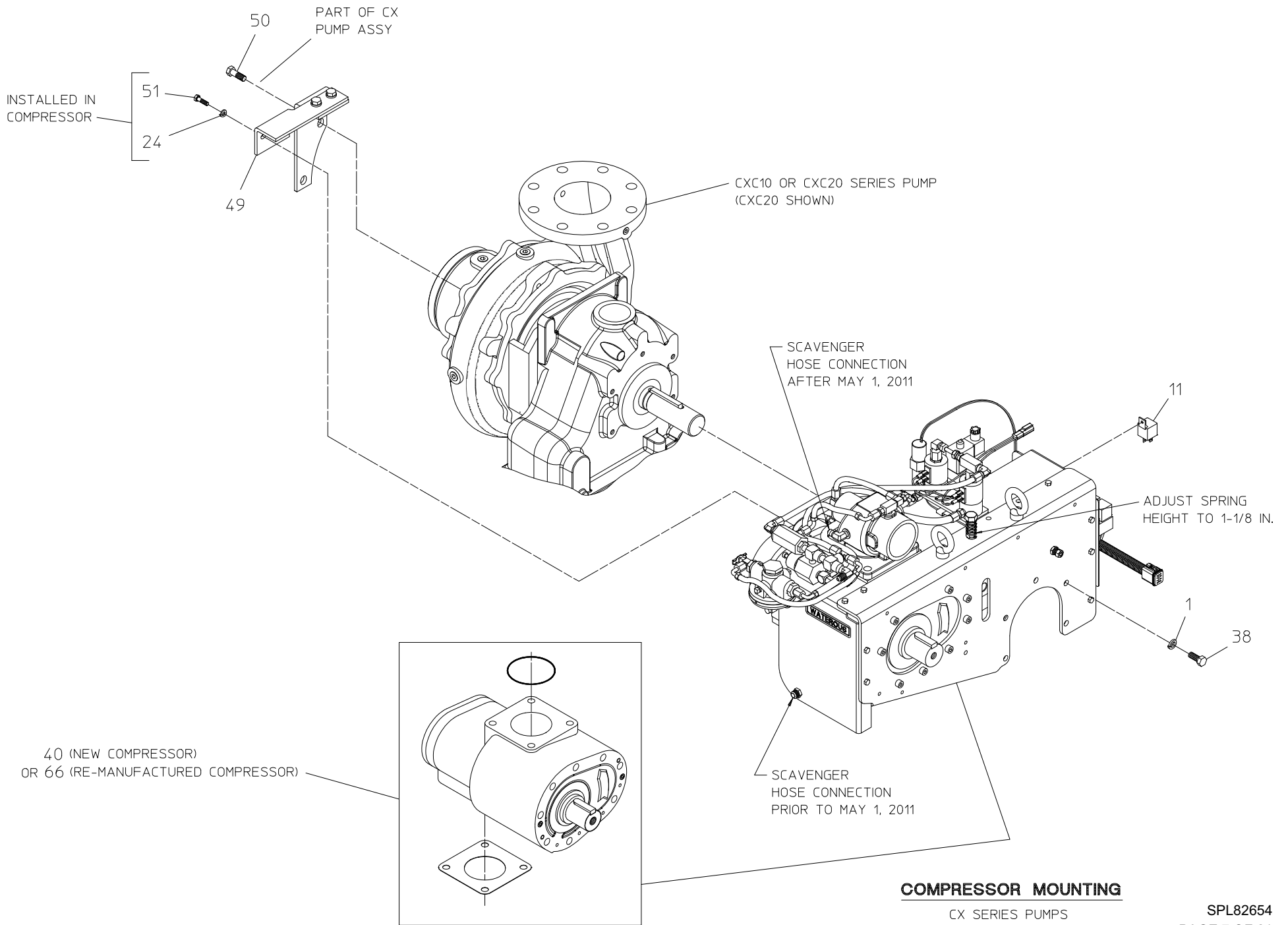

Clutch, Sprocket and Belt Installation, S100 and CX Series Pumps

REF. NO.	DESCRIPTION
2	Drive Sprocket
3	Driven Sprocket
4	Sprocket Retainer
5	Lock Washer, 16 mm
6	Hex Hd Screw, M16 x 2 x 40 mm
7	Air Clutch
8	Air Clutch Subassembly
9	Nylon Tubing, 1/4 x 6 in.
10	Bulkhead Union, 1/4 Tube
12	Drive Belt
18	Nylon Tubing, 1/4 x 10 in.
19	Male Elbow, 1/4 Tube
20	Solenoid Valve, 3-Way

REF. NO.	DESCRIPTION
21	Cable Plug
22	Check Valve, 1/4 in.
24	Lock Washer, 8 mm
29	Female Elbow, 1/4 Tube x 1/8 NPT, 90°
30	Pipe Nipple, 1/8 x 4-1/2 in.
31	Knurled Cup Set Screw, 3/8-24 x 3/8 in.
32	Knurled Cup Set Screw, 3/8-24 x 3/4 in.
39	Idler Sprocket
46	Hex Hd Screw, M8 x 1.25 x 25 mm
47	Idler Spacer
48	Air Clutch Repair Kit
67	Air Clutch Rotating Union Repair Kit

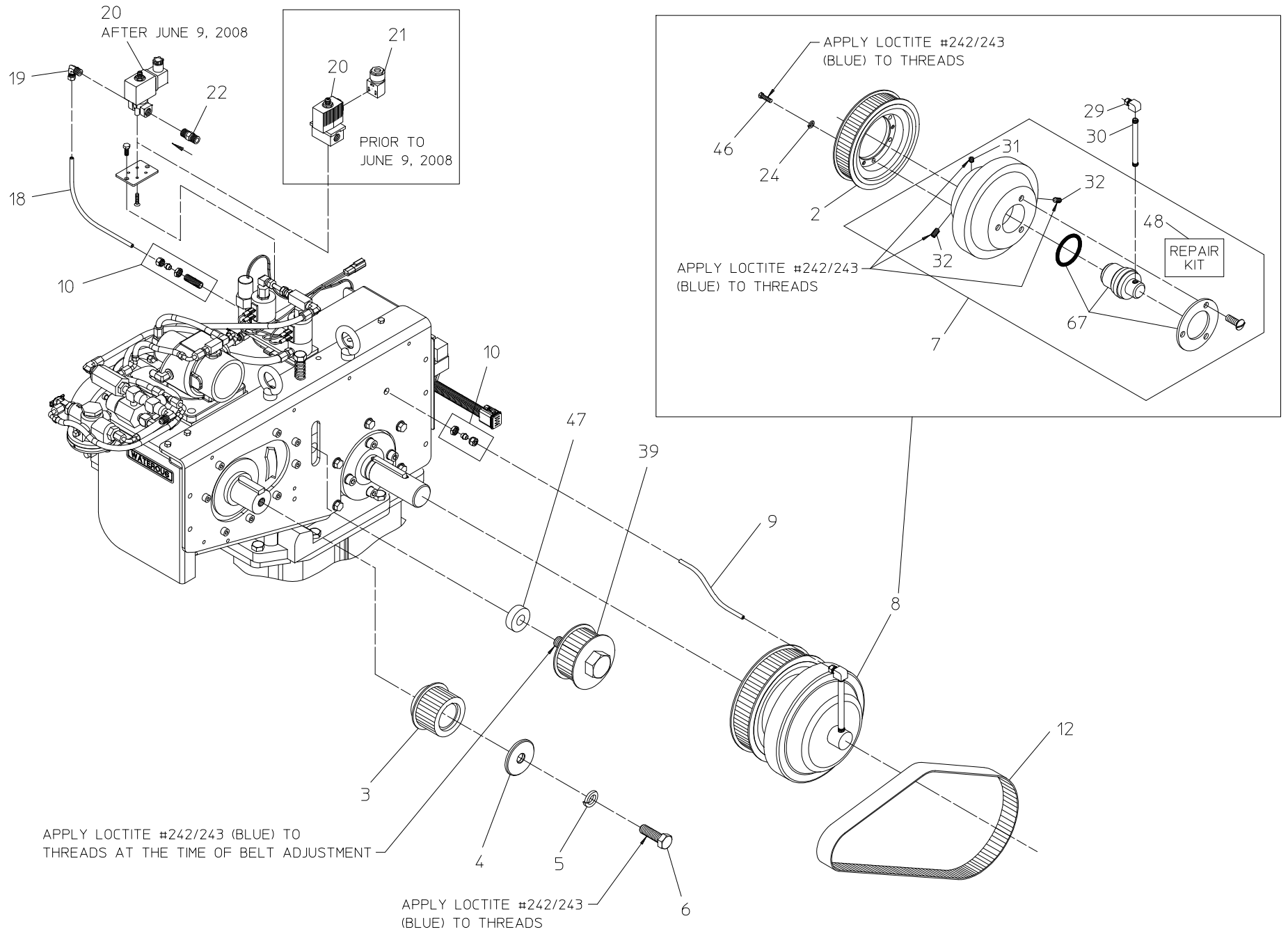

CLUTCH, SPROCKET AND BELT INSTALLATION

S100 AND CX SERIES PUMPS

Belt Cover Installation, S100 and CX Series Pumps

REF. NO.	DESCRIPTION
13	Lock Washer, 1/4 in.
14	Hex Hd Screw, 1/4-20 x 3/4 in.

REF. NO.	DESCRIPTION
15	Belt Cover Assembly

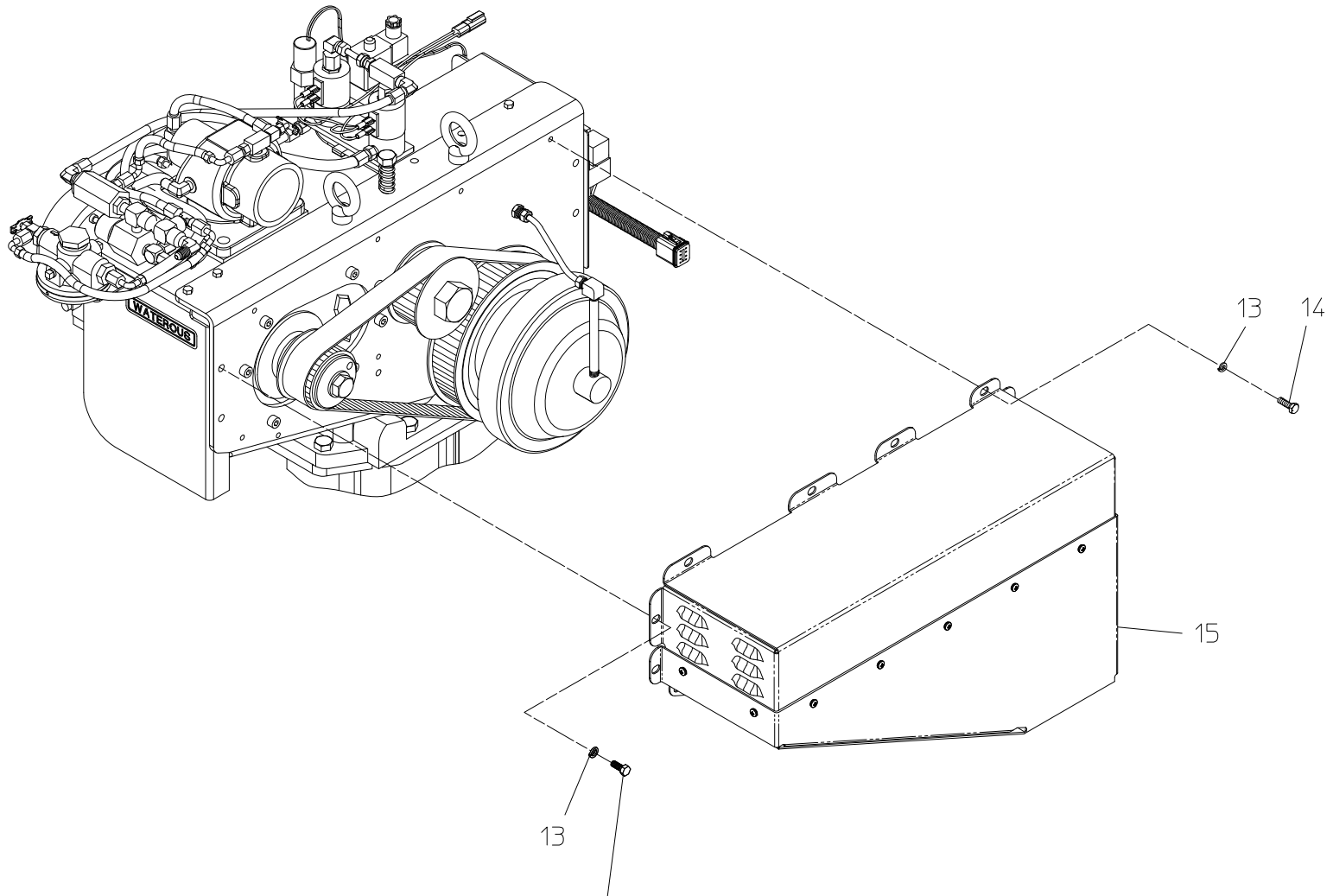

PART OF AIR COMPRESSOR

BELT COVER INSTALLATION

S100 AND CX SERIES PUMPS

Compressor Mounting, TC10 Series P.T.O.

REF. NO.	DESCRIPTION
1	Lock Washer, 10 mm
5	Lock Washer, 16 mm
11	SPDT Relay
38	Hex Hd Screw, M10 x 1.5 x 10 mm

REF. NO.	DESCRIPTION
40	Air Compressor (New)
49	Compressor Bracket
63	Hex Hd Screw, M16 x 2 x 30 mm
66	Air Compressor (Re-Manufactured)

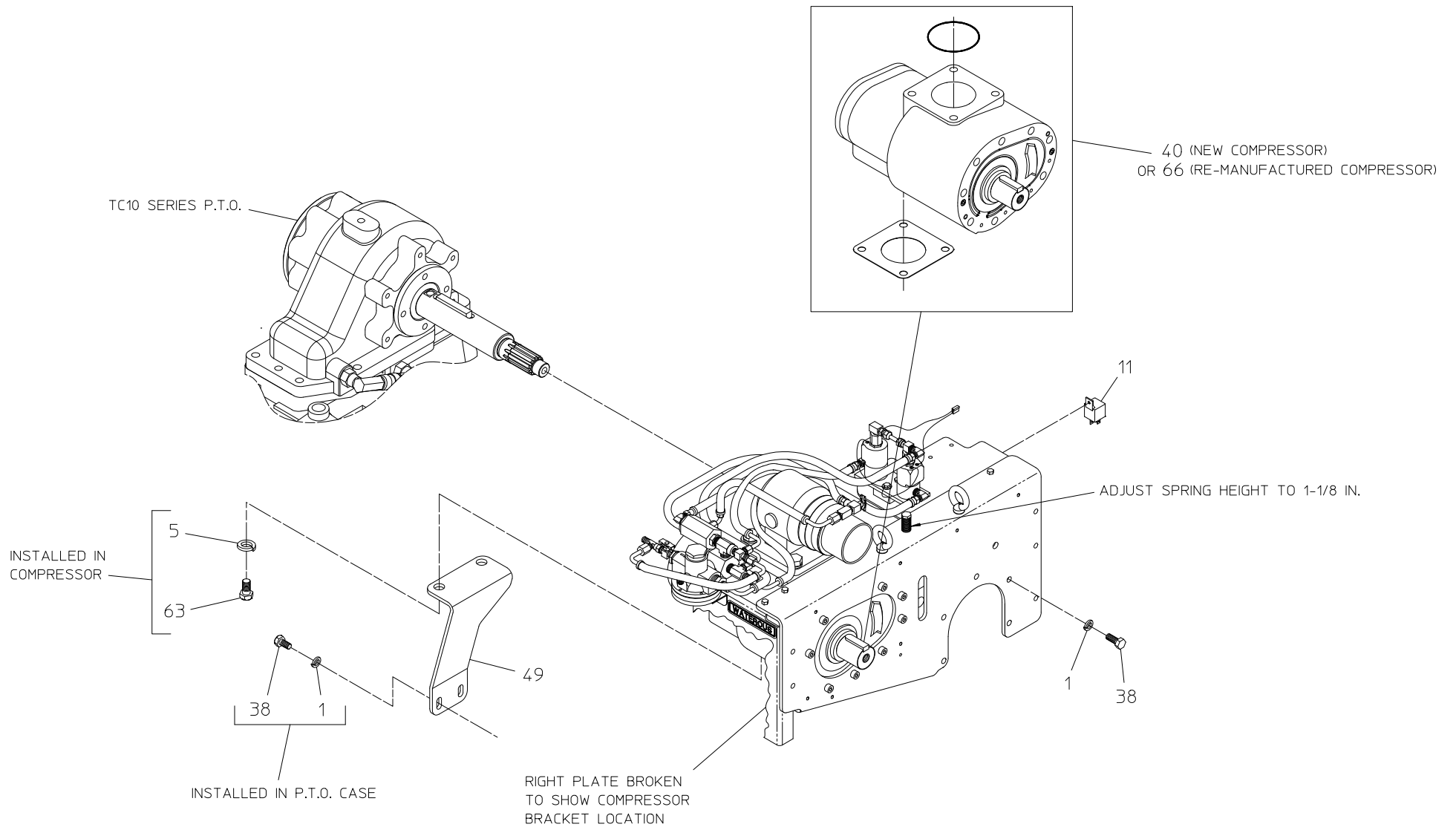

COMPRESSOR MOUNTING

TC10 SERIES P.T.O.

Compressor Mounting, TC20 Series P.T.O.

REF. NO.	DESCRIPTION
1	Lock Washer, 3/8 in.
5	Lock Washer, 16 mm
11	SPDT Relay
38	Hex Hd Screw, 3/8-16 x 1 in.

REF. NO.	DESCRIPTION
40	Air Compressor (New)
49	Compressor Bracket
63	Hex Hd Screw, M16 x 2 x 30 mm
66	Air Compressor (Re-Manufactured)

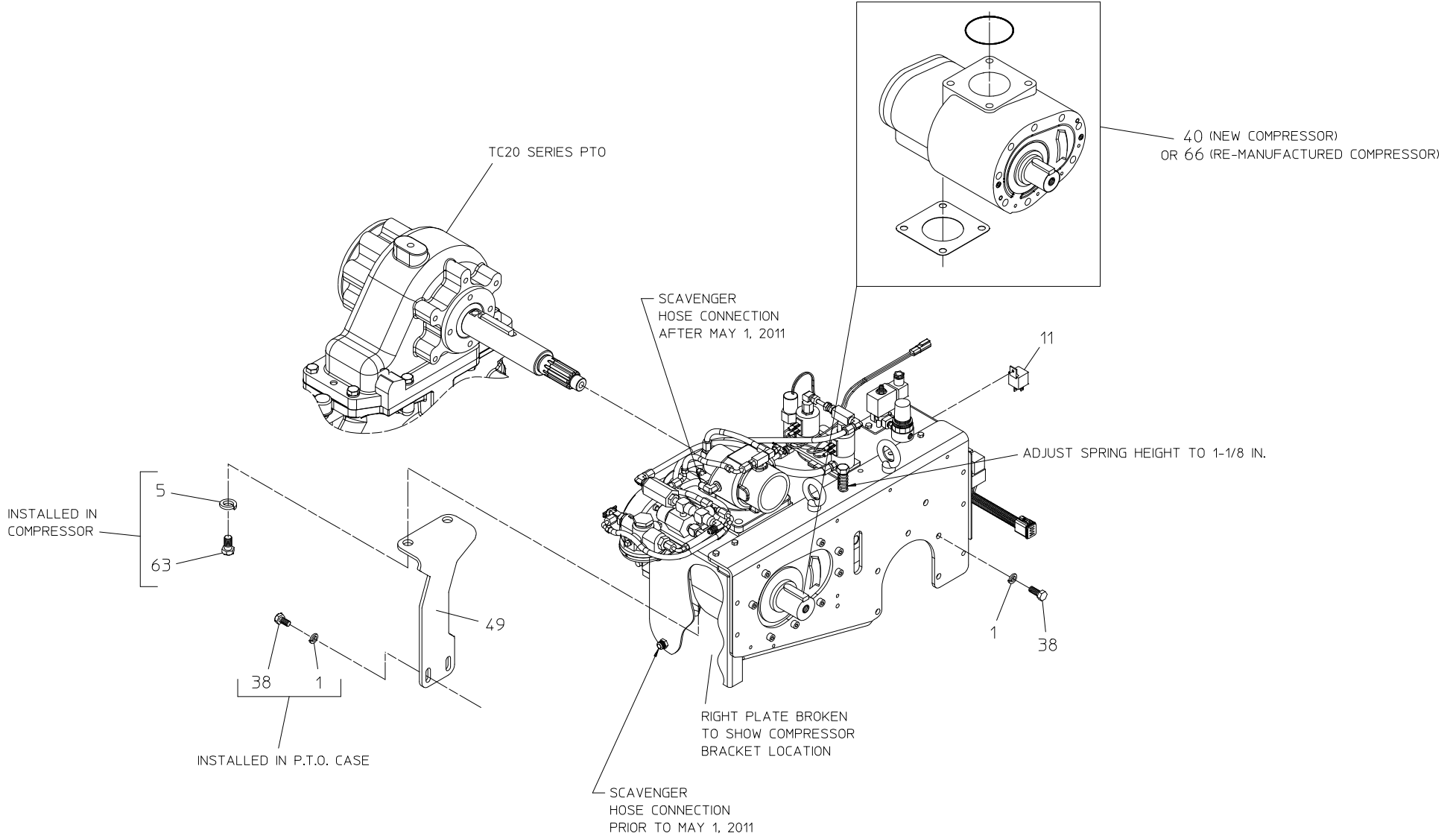

COMPRESSOR MOUNTING

TC20 SERIES P.T.O.

Clutch, Sprocket and Belt Installation, TC10 and TC20 Series P.T.O.

REF. NO.	DESCRIPTION
2	Drive Sprocket
3	Driven Sprocket
4	Sprocket Retainer
5	Lock Washer, 16 mm
6	Hex Hd Screw, M16 x 2 x 40 mm
7	Air Clutch
8	Air Clutch Subassembly
12	Drive Belt
13	Lock Washer, 1/4 in.
14	Hex Hd Screw, 1/4-20 x 3/4 in.
20	Solenoid Valve, 3-Way
21	Cable Plug
22	Check Valve, 1/4 in.
39	Idler Sprocket
47	Idler Spacer
48	Clutch Repair Kit
52	Set Screw, 1/2-13 x 3/4 in.
53	Square Key, 1/2 x 1/2 x 3.1 in.
54	Tee Fitting
55	Elbow Fitting
56	Nylon Tubing, 5/32 x 30 in.

REF. NO.	DESCRIPTION
57	Socket Hd Screw, 3/8-16 x 1-3/4 in.
58	Cable Tie, 3/16 x 7-3/8 in.
59	Symmetrical Grommet, 3/16 I.D.
60	Hex Hd Screw, 3/8-16 x 1-1/4 in.
61	Rubber Grommet, SBR
62	Anti-Rotation Bracket
64	Brass Pipe Bushing
65	Nylon Tubing, 1/4 x 8 in.
68	Fiberglass Sleeve, 12 in.
69	Air Line, 5/32 x 7 in.
70	Fiberglass Sleeve, 6 in.
71	Air Line, 5/32 x 10 in.
72	Fiberglass Sleeve, 9 in.
73	Air Regulator

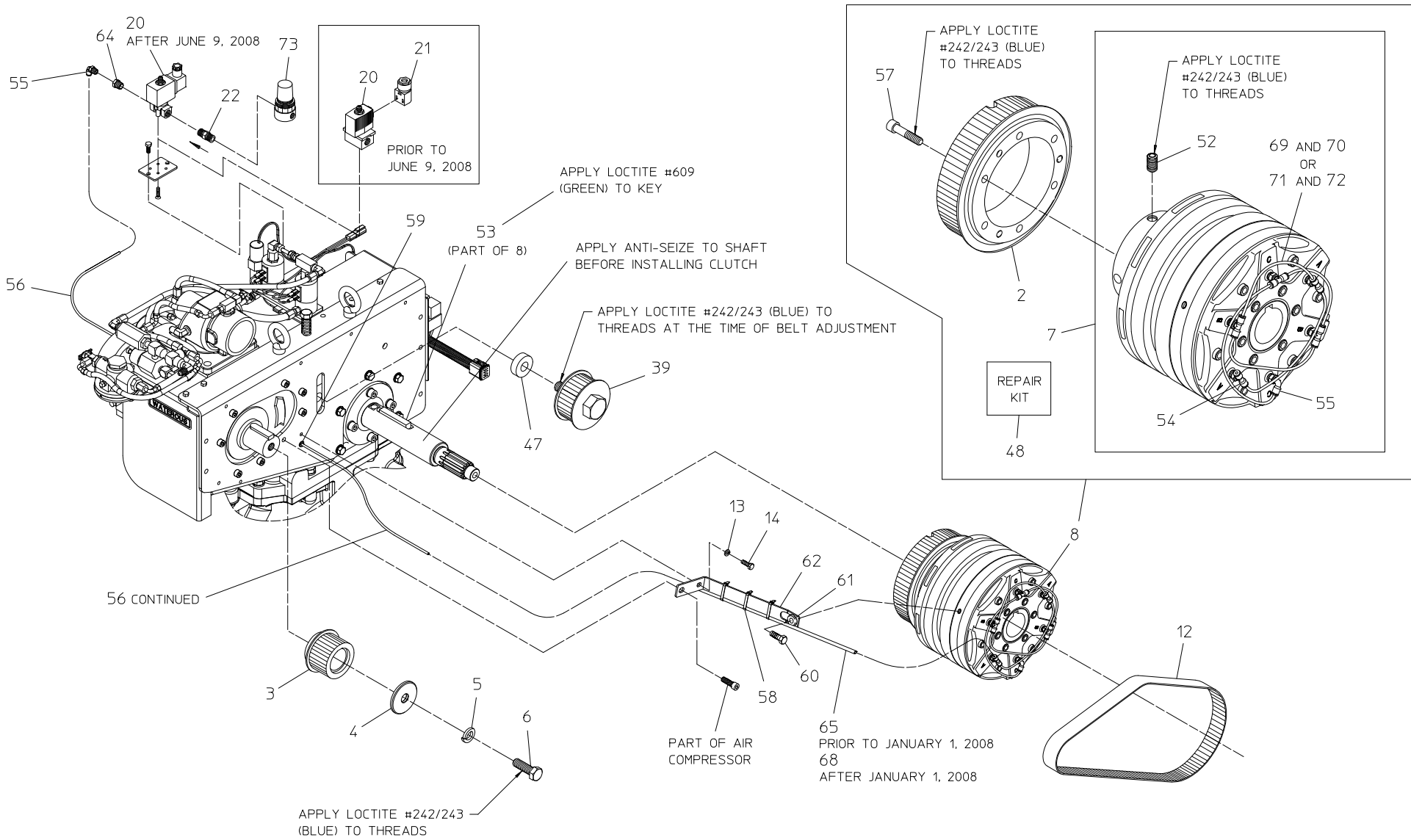

CLUTCH, SPROCKET AND BELT INSTALLATION

TC10 & TC20 SERIES P.T.O. (TC20 SHOWN)

Belt Cover Installation, TC10 and TC20 Series P.T.O.

REF. NO.	DESCRIPTION
13	Lock Washer, 1/4 in.
14	Hex Hd Screw, 1/4-20 x 3/4 in.

REF. NO.	DESCRIPTION
15	Belt Cover Assembly

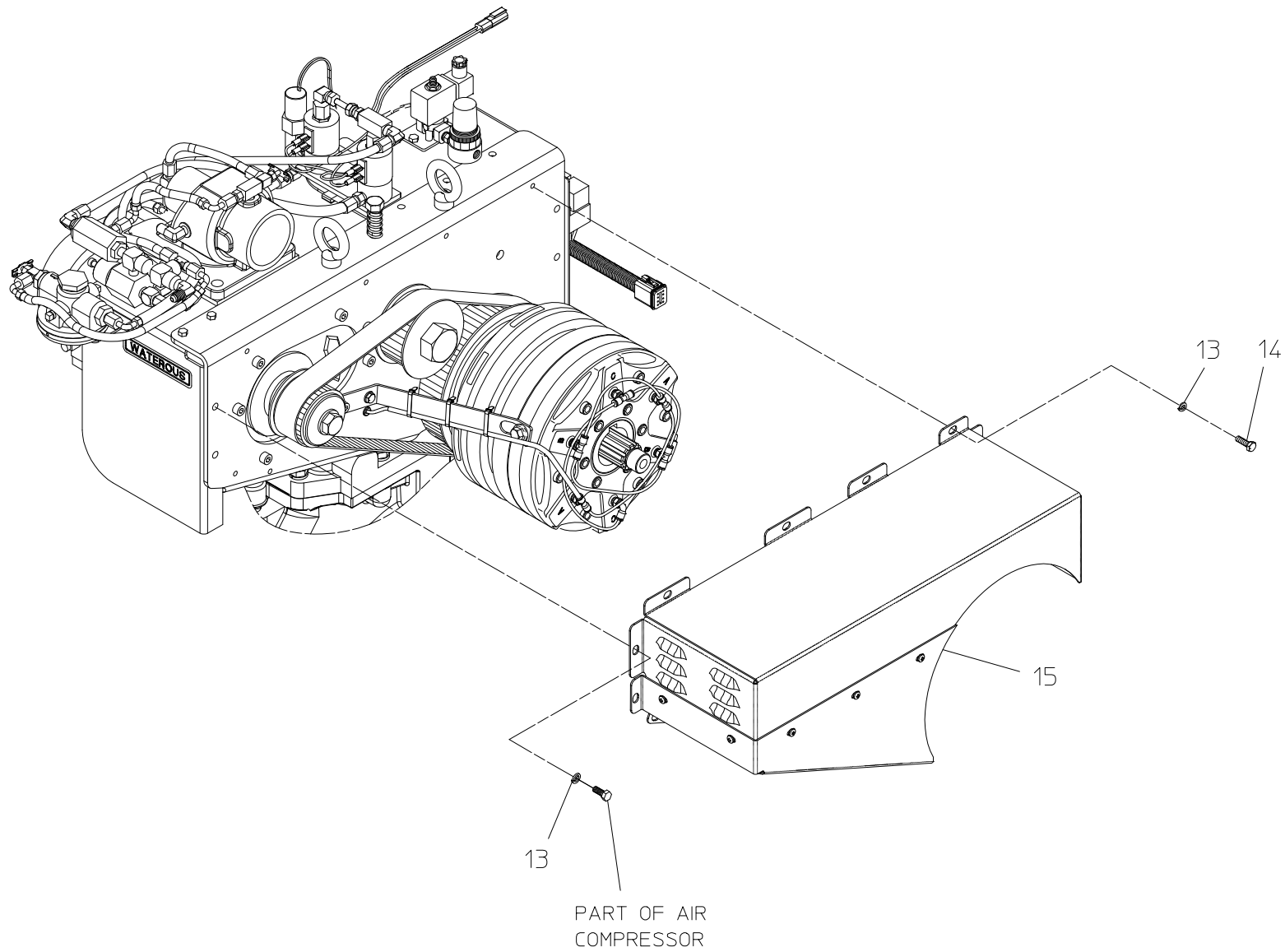

BELT COVER INSTALLATION

TC10 & TC20 SERIES P.T.O. (TC20 SHOWN)

Oil Cooler, Sump and Panel Components

REF. NO.	DESCRIPTION
25	Oil Sump
26	Oil Temperature Sensor
27	Heat Exchanger (Oil Cooler)
28	Oil Filter Canister
33	Relief Valve
34	Warning Plate
35	Hose Specification Plate
36	Y Strainer with Fittings, 1 in.
37	Ball Valve, 1/2 in.
41	Auto Sync Plate

REF. NO.	DESCRIPTION
42	Air/Oil Filter Canister
43	Air Filter
44	Oil Temperature Gauge
45	Minimum Pressure Valve
75	Air Filter Elbow
76	Auto-Sync Plate with Switch and Wiring
77	Air/Oil Separator with Minimum Pressure Valve
78	Heat Exchanger with Oil Filter
79	Oil Sump with Fittings
80	Air Pressure Switch

Note: These components are installed remotely from the compressor on the vehicle by the OEM.

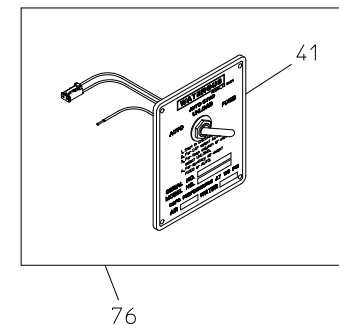
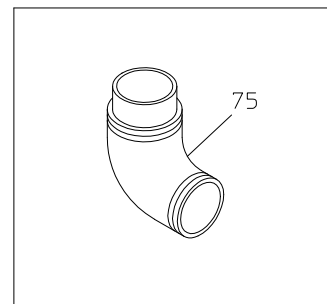
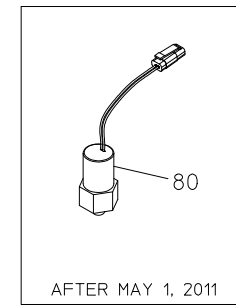
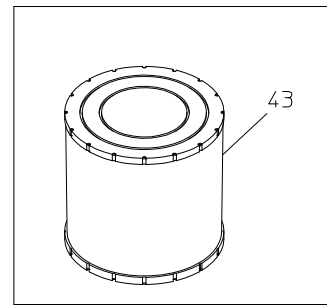
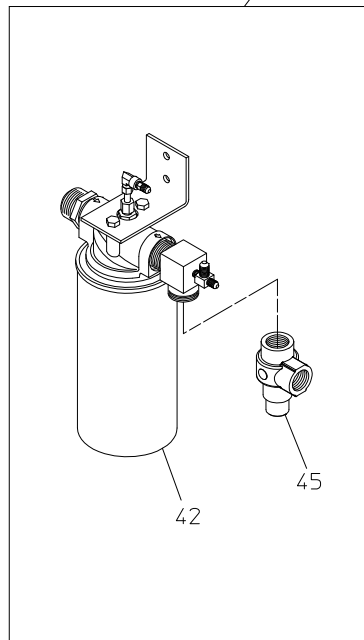
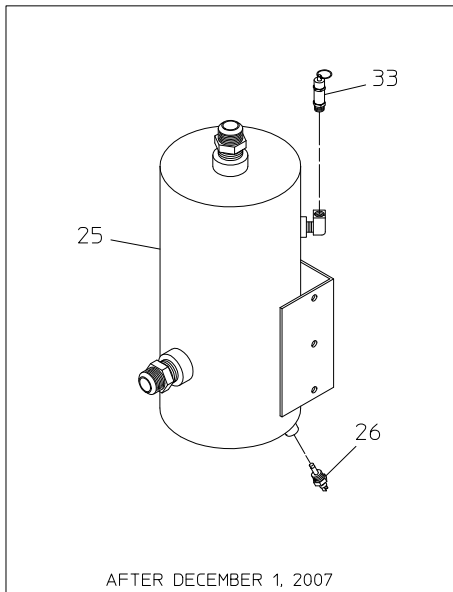
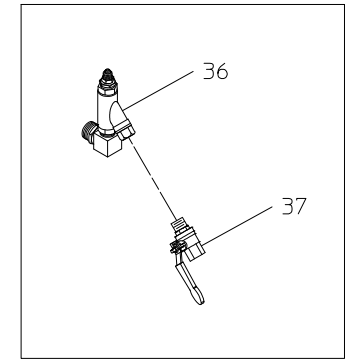
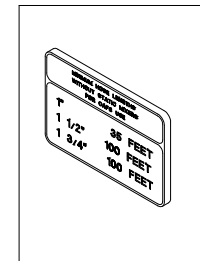
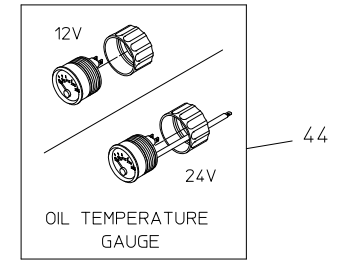
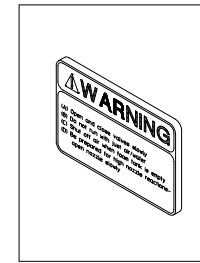
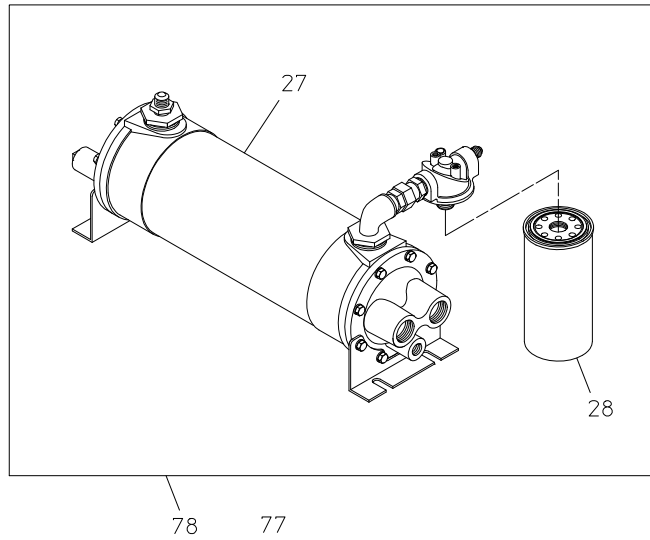
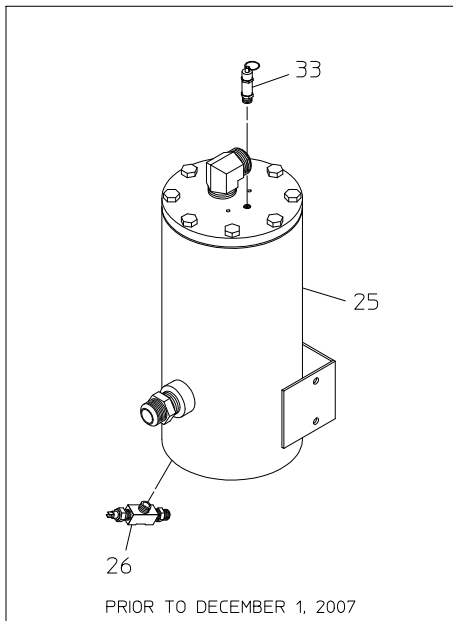

**OIL COOLER, SUMP AND
PANEL COMPONENTS**