



Document Number	Issue Date	Rev. Date
SPL82656	01/05/04	9/10/24

HL Series Fire Pump Service Parts List

Models HL200 and HL300

Components		See Pages
Intake Adapters		2, 3
Intake and Discharge Fittings		4, 5
Crossover and Discharge Manifold Assembly		6, 7, 8, 9
Primer Assembly	Without PIV (Priming Isolation Valve)	10, 11
	With PIV (Priming Isolation Valve)	12, 13
Body and Impeller Shaft Assembly		14, 15
Impeller Shaft and Pedestal Assembly		16, 17
RTP Foam System		18, 19, 20, 21
Control Panel		22, 23
Optional Items		24, 25
Cross Section View of Pump		26, 27

Intake Adapters

REF. NO.	DESCRIPTION
5	Mechanical Seal Replacement Kit
8	Hex Hd Screw, M12-1.75 x 30
9	Lock Washer, 12 mm
11	Wear Ring
42	Gasket / Shim / O-ring Replacement Kit
49	Lock Washer, 8 mm
51	Blind Flange
52	Hex Hd Screw, M8-1.25 x 25
62	O-ring, 1-5/8 x 1-7/8 in.
69	Check Valve, 1/2 NPT
70	Male Connector, 1/2 NPT x 1/2 Tube
71	Priming Intake Tube
86	Intake Adapter Subassembly
87	Foam Flange

REF. NO.	DESCRIPTION
88	Blind Flange
89	O-ring, 11 x 11-3/8 in.
90	Outboard Bearing
91	O-ring, 4-1/2 x 4-3/4 in.
92	Pipe Plug, 1/2 NPT
93	Drive Screw, #6 x 1/4 in.
94	Serial Plate
109	Storz Fitting, 110 mm x 4 BSP
110	Storz Cap, 110 mm
111	Storz Fitting, 150 mm x 4 BSP
112	Storz Cap, 150 mm
116	Intake Manifold
203	Intake Screen

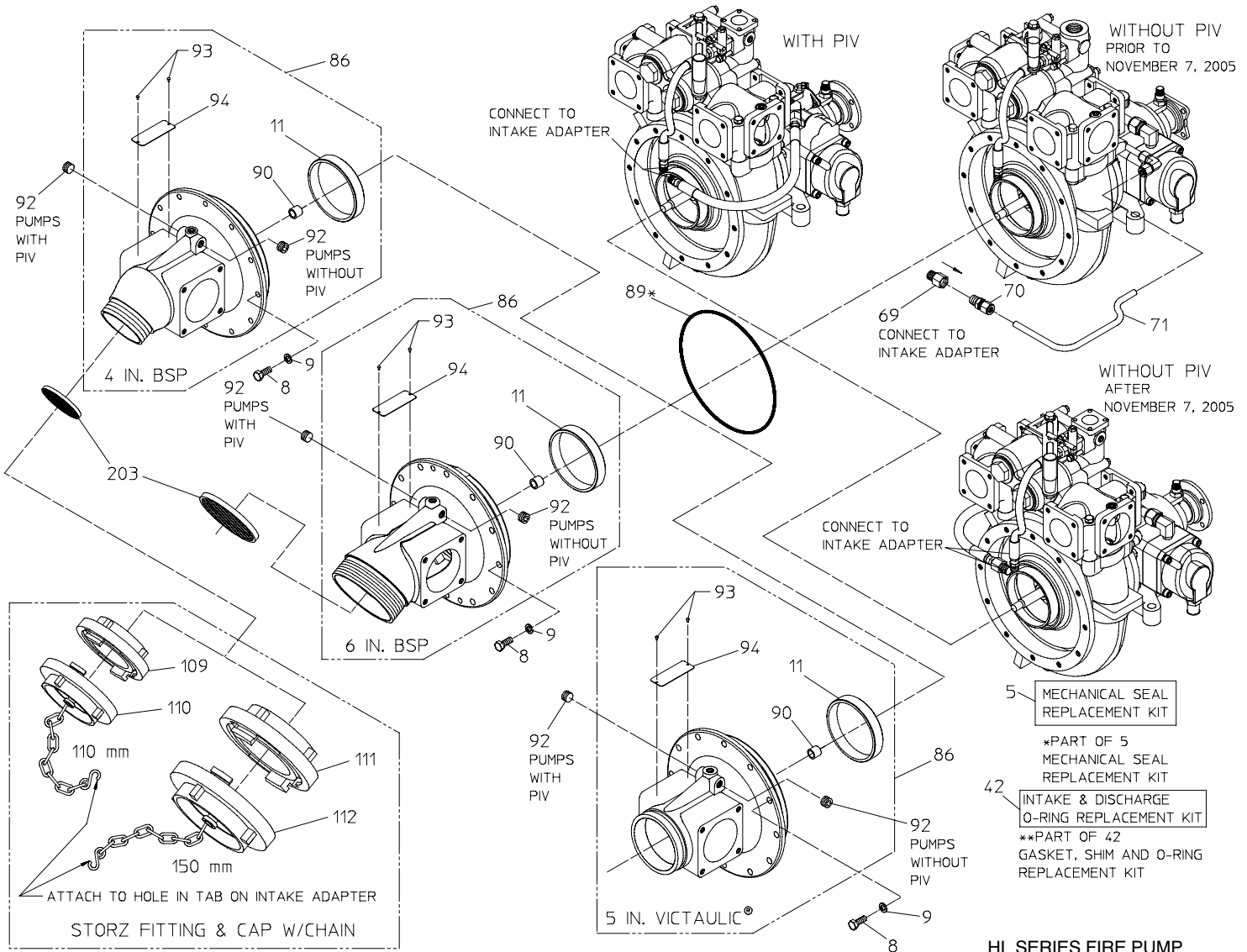
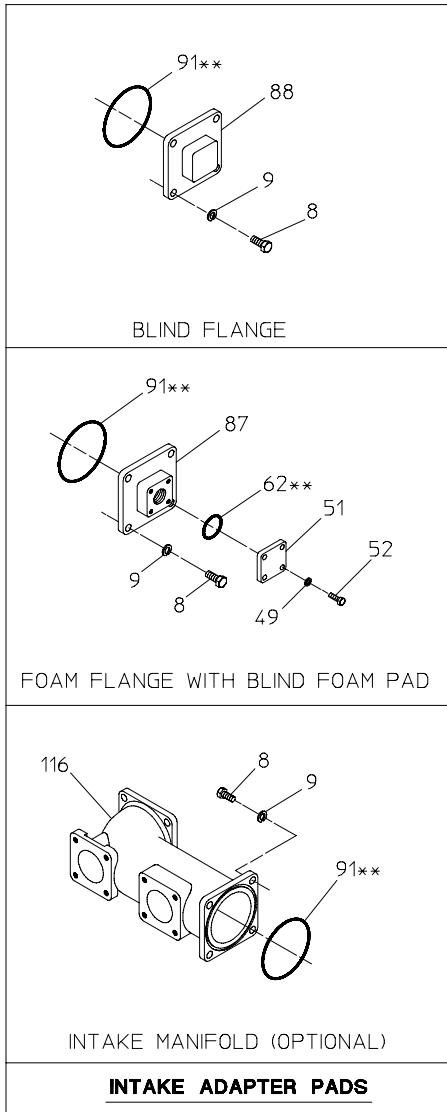

INTAKE ADAPTERS

Intake and Discharge Fittings

REF. NO.	DESCRIPTION
42	Gasket / Shim / O-ring Replacement Kit
64	Lock Washer, 10 mm
97	Hex Hd Screw, M10-1.5 x 30
98	Discharge Valve
99	O-ring, 93 mm x 99 mm
100	Discharge Elbow
101	Blind Flange
102	Tapped Flange, 1 BSP
103	Tapped Flange, 2-1/2 BSP

REF. NO.	DESCRIPTION
104	O-ring, 3-3/8 x 3-5/8 in.
105	Discharge Elbow, 90°, 1 in. BSP Tap
106	Discharge Elbow, 90°, 1 in. NPT Tap
107	Pipe Plug, 1 BSP
108	Pipe Plug, 1 NPT
113	Storz Fitting, 65 mm x 2.5 BSP
114	Storz Cap, 65 mm
115	Tapped Flange, 1 NPT

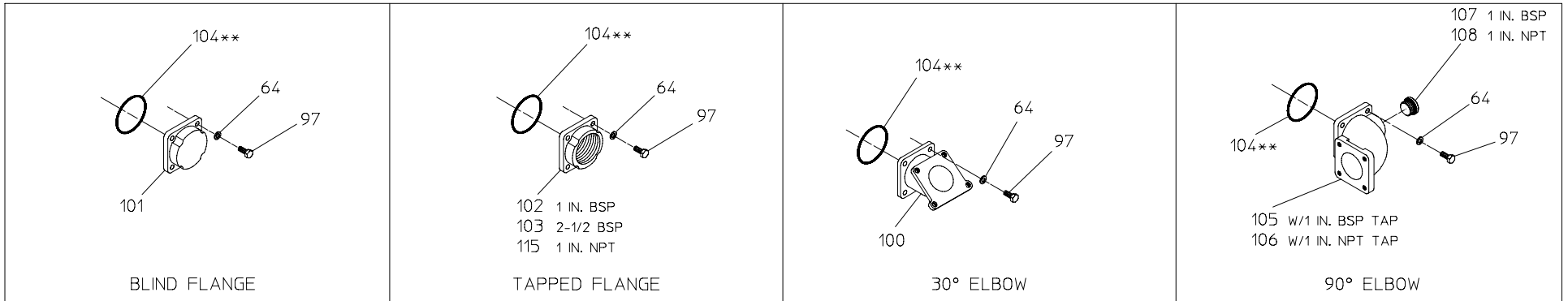

INTAKE & DISCHARGE FLANGES AND ELBOWS

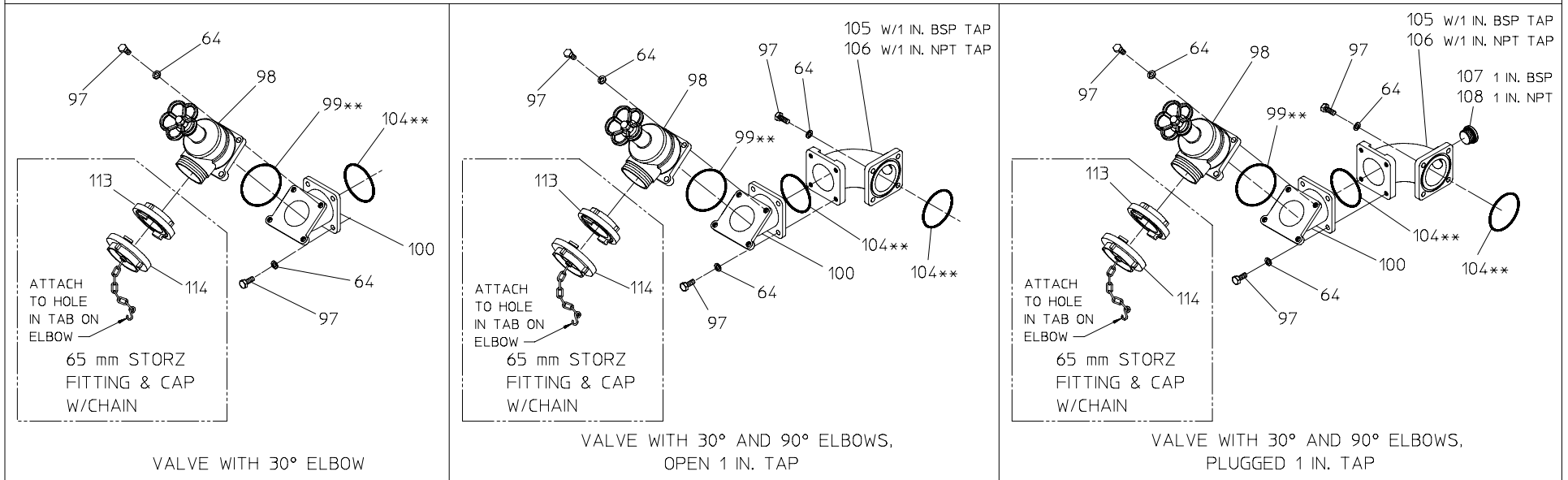

DISCHARGE VALVES

42 INTAKE & DISCHARGE O-RING REPLACEMENT KIT
**PART OF 42 GASKET, SHIM AND O-RING REPLACEMENT KIT

Crossover & Discharge Manifold Assembly (After December 4, 2009)

REF. NO.	DESCRIPTION
9	Lock Washer, 12 mm
42	Gasket / Shim / O-ring Replacement Kit
45	O-ring, 1-3/4 x 2 in.
46	Transfer Valve, 1-1/2 in.
47	Interstage Manifold
48	Hex Hd Screw, M8-1.25 x 80
49	Lock Washer, 8 mm
50	Transfer Valve Handle
51	Blind Flange (Optional)
52	Hex Hd Screw, M8-1.25 x 25
53	Hex Hd Screw, M8-1.25 x 45
54	Hose Assembly, 1/2 HPT x 16
56	Stud, #10-32 x 2 in.
57	Ball Joint Linkage
58	Ball Valve Handle
59	Lock Washer, #10
60	Hex Nut, #10-32
61	Hex Hd Screw, M8-1.25 x 120
62	O-ring, 1-5/8 x 1-7/8 in.

REF. NO.	DESCRIPTION
63	Pipe Plug, 1/4 BSP
64	Lock Washer, 10 mm
65	Hex Nut, M10-1.5
66	Ball Valve, 1/2 NPT
67	Handle
80	Discharge Manifold
81	O-ring, 3-5/8 x 3-7/8 in.
82	O-ring, 1-1/8 x 1-1/4 in.
83	Hex Hd Screw, M12-1.75 x 120
84	Thermal Relief Valve
85	Discharge Relief Valve Subassembly
95	O-ring, 1-7/8 x 2-1/8 in.
119	O-ring, 1 x 1-1/8 in.
120	End Cap Strainer
121	Strainer
198	Pipe Plug, 1/4 in.
216	Lifting Bracket (Used if Operator's Panel is not Furnished by Waterous)
217	High Pressure Stage Manifold (Optional)
221	Tapped Flange, 1-1/4 BSP (Optional)

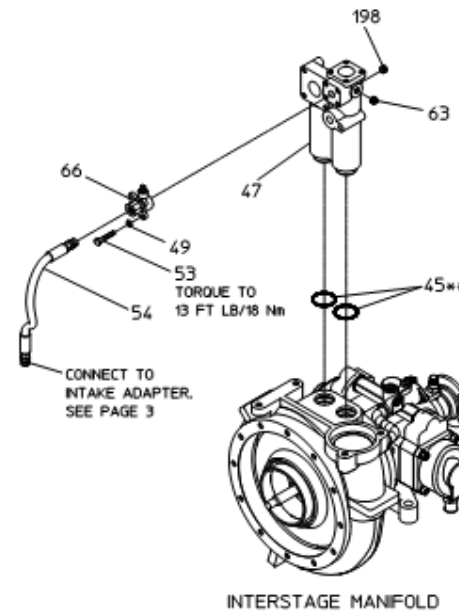
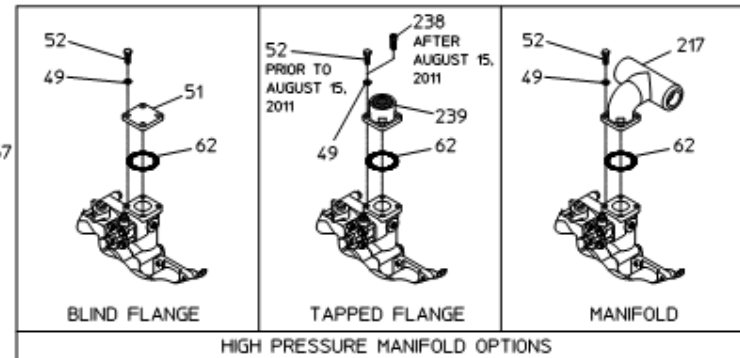
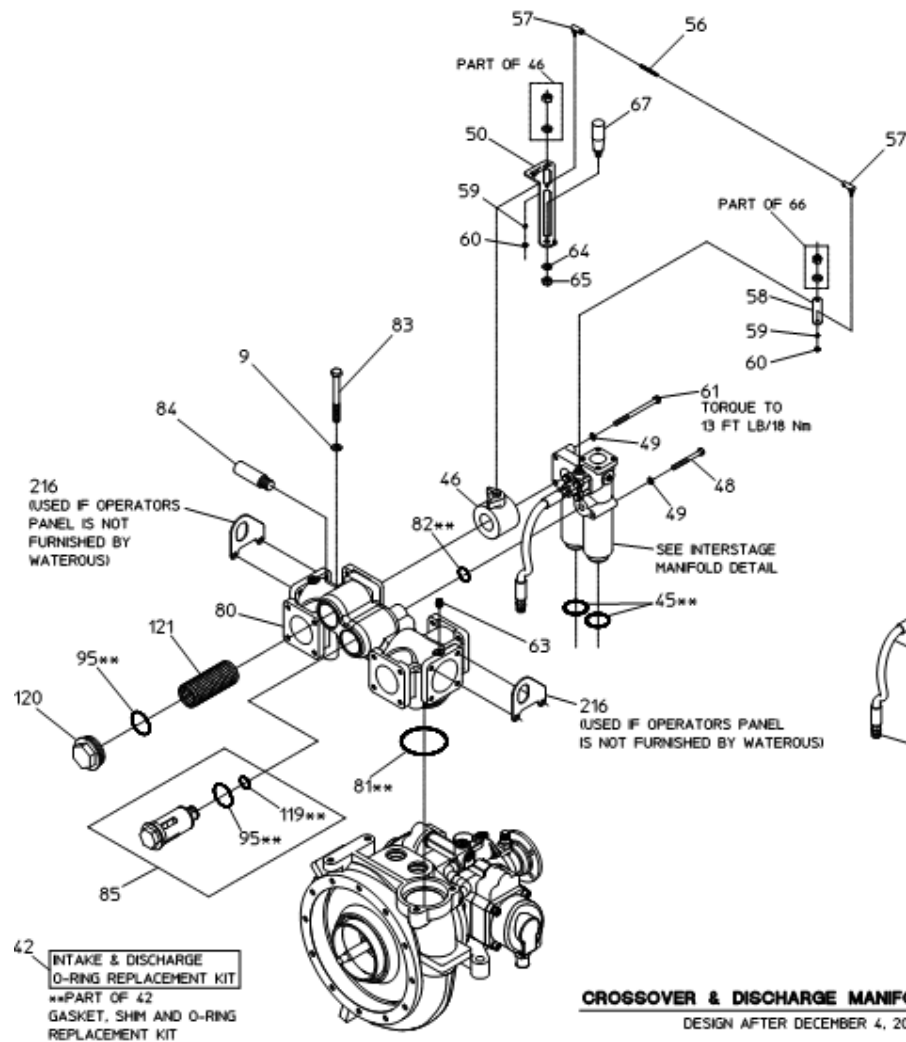

CROSSOVER & DISCHARGE MANIFOLD ASSEMBLY
 DESIGN AFTER DECEMBER 4, 2009

Crossover & Discharge Manifold Assembly (Prior to December 4, 2009)

REF. NO.	DESCRIPTION
9	Lock Washer, 12 mm
42	Gasket / Shim / O-ring Replacement Kit
45	O-ring, 1-3/4 x 2 in.
46	Transfer Valve, 1-1/2 in.
47	Interstage Manifold
48	Hex Hd Screw, M8-1.25 x 80
49	Lock Washer, 8 mm
50	Transfer Valve Handle
51	Blind Flange
52	Hex Hd Screw, M8-1.25 x 25
53	Hex Hd Screw, M8-1.25 x 45
54	Hose Assembly, 1/2 HPT x 16
56	Stud, #10-32 x 2 in.
57	Ball Joint Linkage
58	Ball Valve Handle
59	Lock Washer, #10
60	Hex Nut, #10-32
61	Hex Hd Screw, M8-1.25 x 120
62	O-ring, 1-5/8 x 1-7/8 in.

REF. NO.	DESCRIPTION
63	Pipe Plug, 1/4 BSP
64	Lock Washer, 10 mm
65	Hex Nut, M10-1.5
66	Ball Valve, 1/2 NPT
67	Handle
80	Discharge Manifold
81	O-ring, 3-5/8 x 3-7/8 in.
82	O-ring, 1-1/8 x 1-1/4 in.
83	Hex Hd Screw, M12-1.75 x 120
84	Thermal Relief Valve
85	Discharge Relief Valve Subassembly
95	O-ring, 1-7/8 x 2-1/8 in.
119	O-ring, 1 x 1-1/8 in.
120	End Cap Strainer
121	Strainer
198	Pipe Plug, 1/4 in.
216	Lifting Bracket (Used if Operator's Panel is not Furnished by Waterous)
217	High Pressure Stage Manifold (Optional)

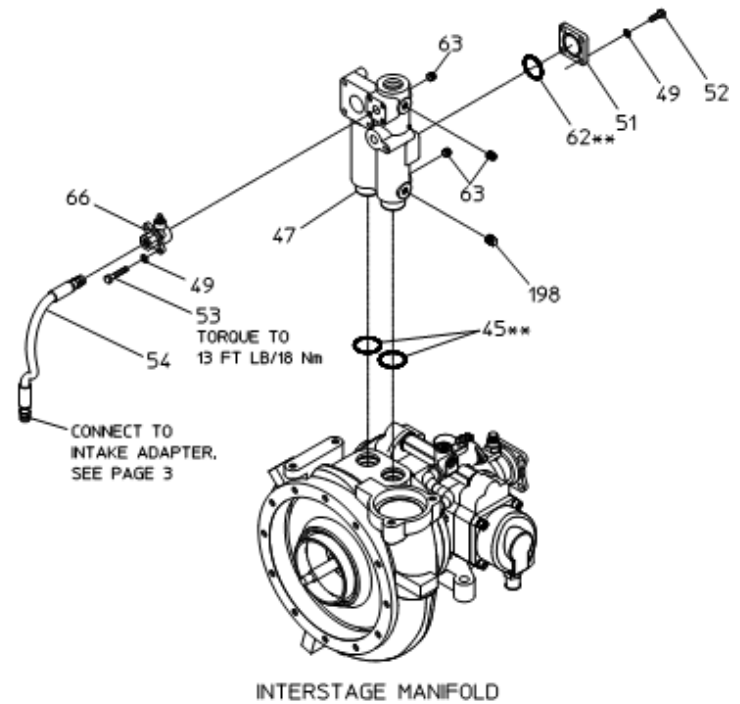
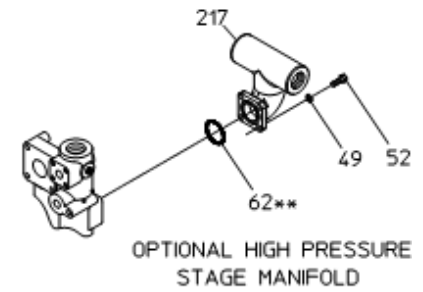
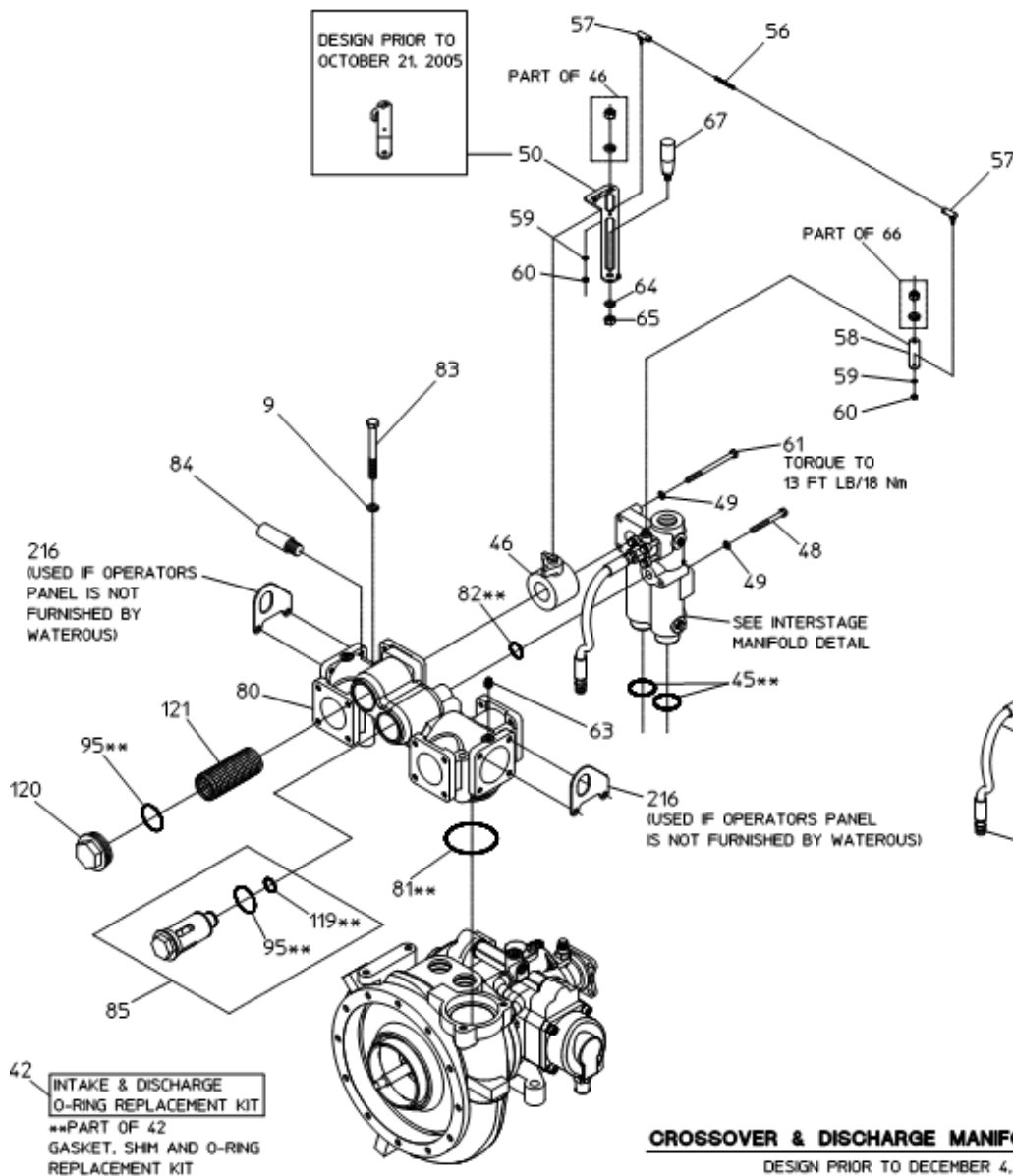

Primer Assembly, Without PIV

REF. NO.	DESCRIPTION
54	Hose Assembly, 1/2 NPT x 16 in.
69	Check Valve, 1/2 NPT
70	Male Connector, 1/2 NPT x 1/2 Tube
71	Priming Intake Tube
72	Socket Hd Screw, M10-1.50 x 65
73	High Collar Lock Washer, 10 mm
74	Piston Primer Subassembly
75	O-ring, 3-3/4 x 4 in.
76	Union Elbow, 1/2 Tube
77	Male Elbow, 1/2 NPT x 3/4 Tube

REF. NO.	DESCRIPTION
78	O-ring, 3/4 x 1 in.
79	Priming Tube
140	Pipe Nipple, 3/4 x 2 in.
141	Primer Muffler
142	Hose Clamp, 3/4 to 1-1/2 in.
147	Primer Repair Kit (Includes O-rings and Quad rings)
149	Hose Barb, 3/4 NPT (m) x 1 in. Hose
167	Priming Tube
197	Street Elbow, 45°, 1/2 NPTF

PRIMER ASSEMBLY WITHOUT PIV

PRIOR TO NOVEMBER 7, 2005

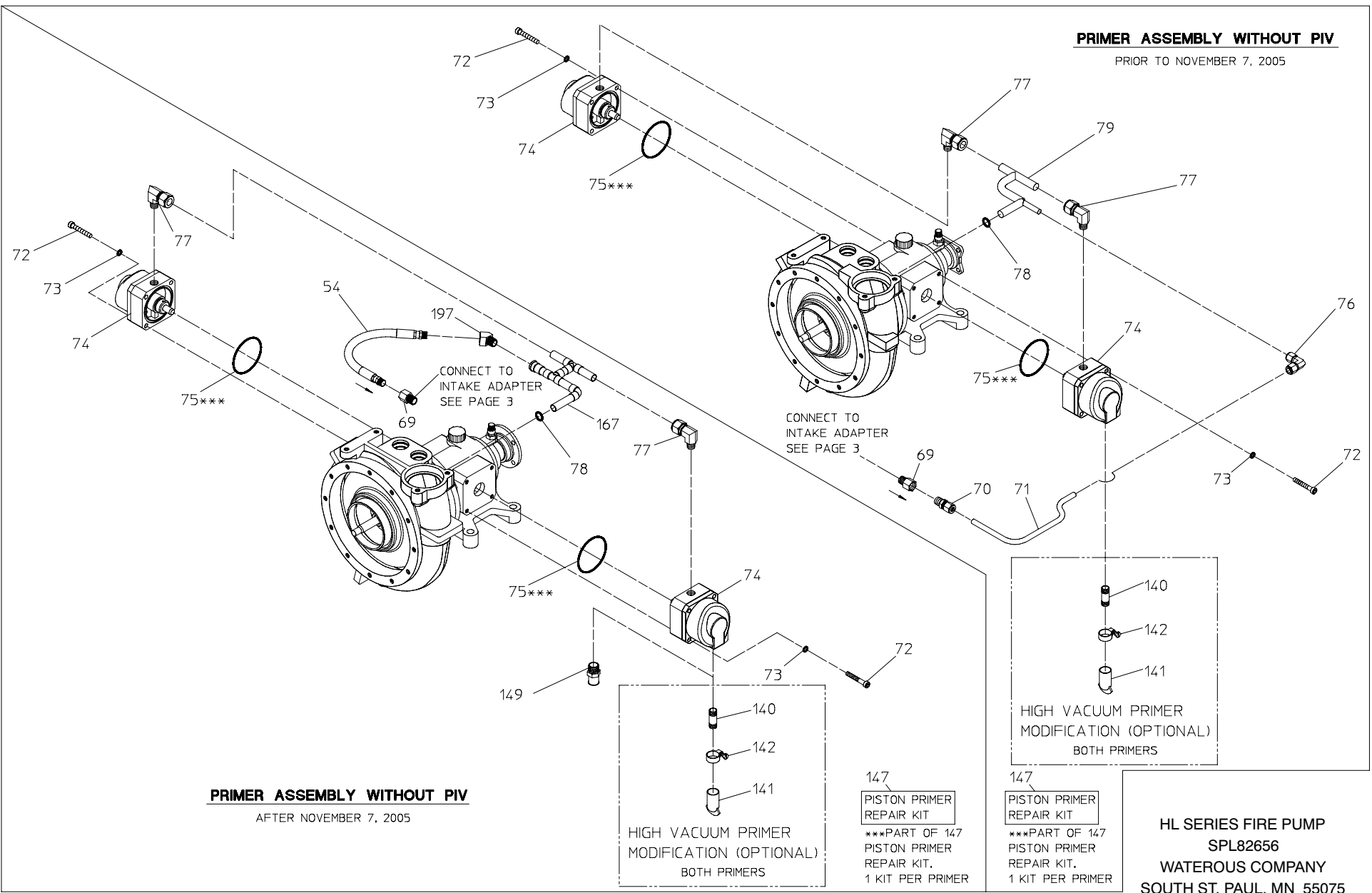

CONNECT TO INTAKE ADAPTER
SEE PAGE 3

CONNECT TO INTAKE ADAPTER
SEE PAGE 3

PRIMER ASSEMBLY WITHOUT PIV

AFTER NOVEMBER 7, 2005

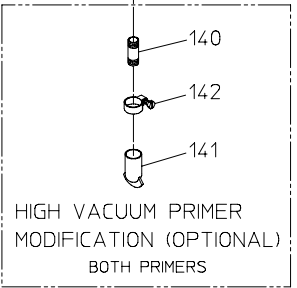

HIGH VACUUM PRIMER
MODIFICATION (OPTIONAL)
BOTH PRIMERS

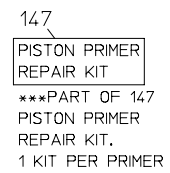

147
PISTON PRIMER
REPAIR KIT
***PART OF 147
PISTON PRIMER
REPAIR KIT.
1 KIT PER PRIMER

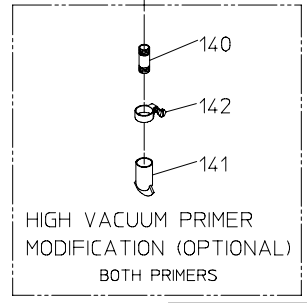

HIGH VACUUM PRIMER
MODIFICATION (OPTIONAL)
BOTH PRIMERS



147
PISTON PRIMER
REPAIR KIT
***PART OF 147
PISTON PRIMER
REPAIR KIT.
1 KIT PER PRIMER

**HL SERIES FIRE PUMP
SPL82656
WATEROUS COMPANY
SOUTH ST. PAUL, MN 55075**

Primer Assembly, With PIV

REF. NO.	DESCRIPTION
24	See Ref. No. 229
72	Socket Hd Screw, M10-1.50 x 65
73	High Collar Lock Washer, 10 mm
74	Piston Primer Subassembly
75	O-ring, 3-3/4 x 4 in.
78	O-ring, 3/4 x 1 in.
82	O-ring, 1-1/8 x 1-1/4 in.
118	Priming Module Gasket
135	Priming Isolation Valve (PIV) Subassembly (Includes 134, 150, 151, 152, 154, 155, 156, 157, 159, 162, 163, 164, 192, 193, 194, 195, 197)
136	Priming Isolation Valve Repair Kit (Includes Seals, Gaskets, Washers, Screw and O-rings)
140	Pipe Nipple, 3/4 x 2 in.
141	Primer Muffler
142	Hose Clamp, 3/4 to 1-1/2 in.
147	Primer Repair Kit (Includes O-rings and Quad rings)
149	Hose Barb, 3/4 NPT (m) x 1 in. Hose
150	Priming Valve Piston
151	Check Valve
152	Priming Valve Seal

REF. NO.	DESCRIPTION
154	Wave Spring
155	Priming Valve Cover
156	Piston Seal
157	Rod Seal
158	3-Way Solenoid Valve (12 V or 24 V)
159	Elbow Connector, 90°, 6mm Tube x 1/8 BSPT
160	Male Connector, 6 mm Tube x 1/4 BSPT
161	Priming Tube
162	Button Hd Screw, M6 x 12 in.
163	Pan Hd Screw, M4 x 10 in.
164	Washer, DIN 9021, M4
165	Nylon Tube, 6 mm x 10 ft.
166	Hose Assembly, 1/2 NPT x 20 in.
192	Pipe Thread Plug, 1/2 BSP
193	Lock Washer, 6 mm
194	Spring Pin, 1/8 x 5/8 in.
195	Priming Valve Body
197	Street Elbow, 45°, 1/2 NPTF
229	O-ring, 1-1/8 x 1-3/8 in. (Formerly Ref. No. 24)

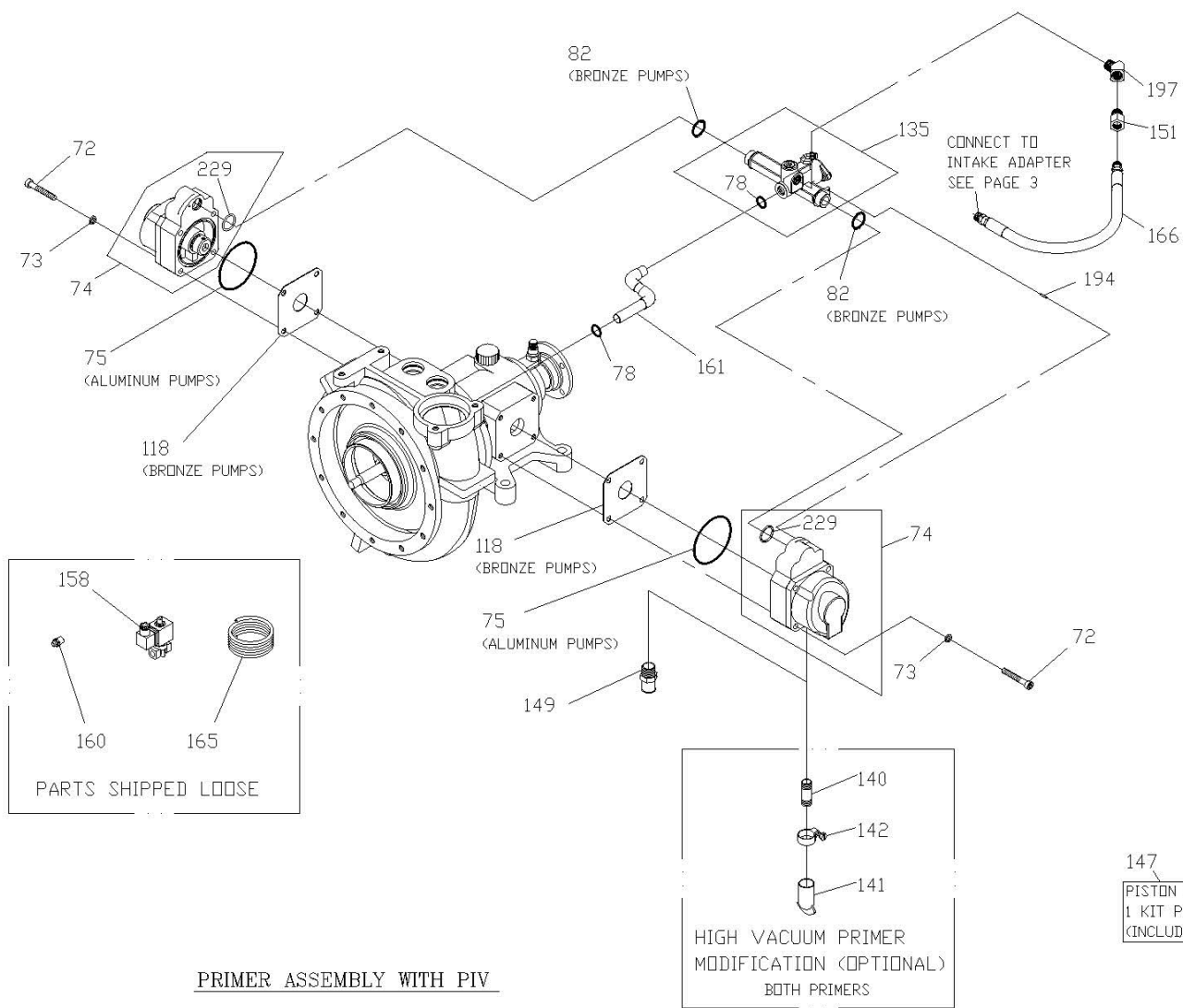

136
 PRIMING ISOLATION VALVE (PIV) REPAIR KIT
 (INCLUDES 75, 78, 82, 118, 152, 154, 156, 163, 164, 229)

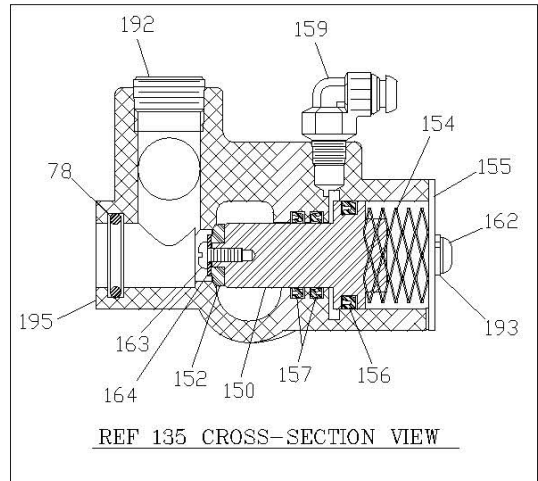

REF 135 CROSS-SECTION VIEW

147
 PISTON PRIMER REPAIR KIT,
 1 KIT PER PRIMER
 (INCLUDES 75, 118, 229)

PRIMER ASSEMBLY WITH PIV

Body & Impeller Shaft Assembly

REF. NO.	DESCRIPTION
1	Volute Body Subassembly
2	Impeller
3	Separator Plate Subassembly
4	Main Stage Impeller
5	Mechanical Seal Replacement Kit
6	O-ring, 2-1/2 x 2-3/4 in.
7	Headless Pipe Plug, 3/8 BSP
8	Hex Hd Screw, M12-1.75 x 30
9	Lock Washer, 12 mm
10	Interstage Bushing

REF. NO.	DESCRIPTION
11	Wear Ring
12	Socket Hd Screw, M12-1.75 x 55
13	Lock Washer, 12 mm
14	Dowel Pin, .375 x 1 in.
15	Rectangular Key, 8 mm x 12 mm x 65 mm
16	O-ring, 2 x 2-3/16 in.
17	O-ring, 13/16 x 15/16 in.
18	Lock Nut, M24-3
19	Nord-Lock [®] Washer, 24 mm
68	Shim Pack (Includes (2) 0.003, 0.005 and (3) 0.010 in. Thick Shims)
239	Headless Pipe Plug, 3/4 NPT

See pages 26 and 27 for Cross-Sectional view.

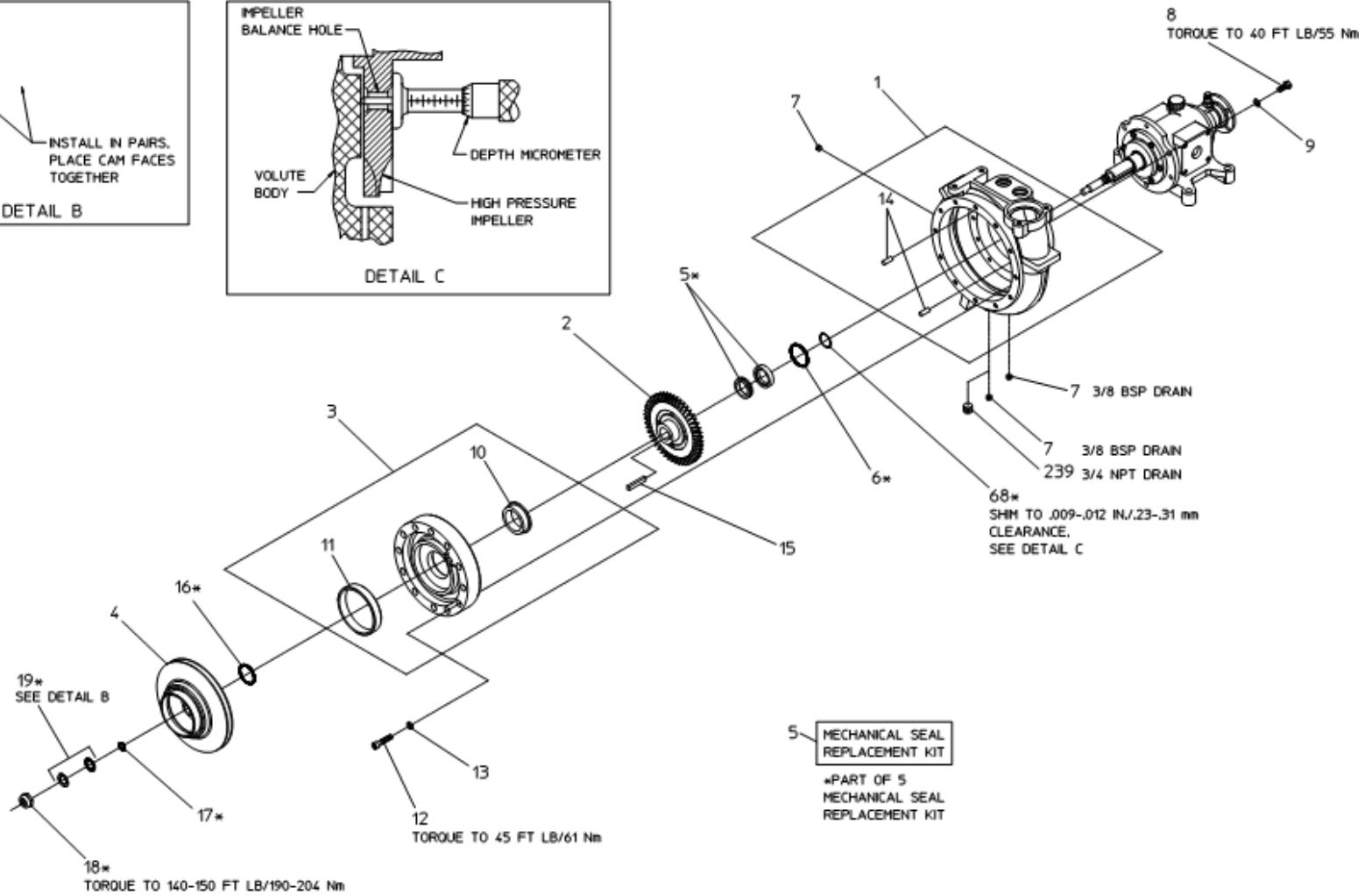
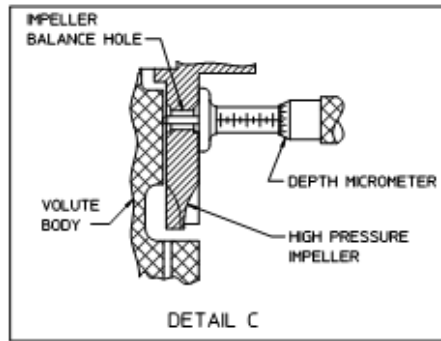
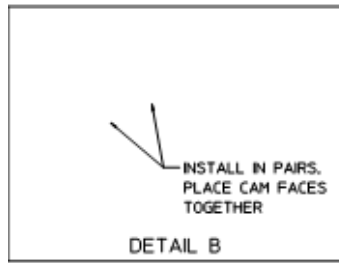

BODY & IMPELLER SHAFT ASSEMBLY

Impeller Shaft & Pedestal Assembly

REF. NO.	DESCRIPTION
18	Lock Nut, M24-3 (Used Prior to April 7, 2005)
20	Oil Seal Housing
21	Oil Seal
22	Bearing Lock Nut
23	Bearing Lock Washer
24	Angular Contact Ball Bearing
25	Impeller Shaft
26	Primer Counterweight
27	Rectangular Key, 8 mm x 12 mm x 30 mm (Used prior to July 1, 2003)
27	Rectangular Key, 8 mm x 12 mm x 46 mm (Used prior to July 1, 2003)
27	Rectangular Key, 8 mm x 12 mm x 55 mm (Used After to July 1, 2003)
28	Primer Eccentric
29	Retaining Ring
30	Single Row Ball Bearing
31	Single Row Ball Bearing
32	Pedestal Body
33	Hex Drain Plug

REF. NO.	DESCRIPTION
34	Copper Flat Washer, 5/8 in.
35	Oil Seal
36	Retaining Ring
37	Impeller Shaft Spacer
38	Magnetic Tachometer Pick Up
39	Dip Stick
40	Tachometer Cable
41	Flat Washer, 24 mm (Used Prior to April 7, 2005)
41	Nord-Lock ® Washer, 24 mm (Used After April 7, 2005)
43	Companion Flange
44	O-ring, 4-3/4 x 4-7/8 in. or 124 mm x 128 mm
49	Lock Washer, 8 mm
52	Hex Hd Screw, M8-1.25 x 25
117	Small Primer Counterweight
196	Hex Nut, M24-3 (Used After April 7, 2005)

See pages 26 and 27 for Cross-Sectional view.

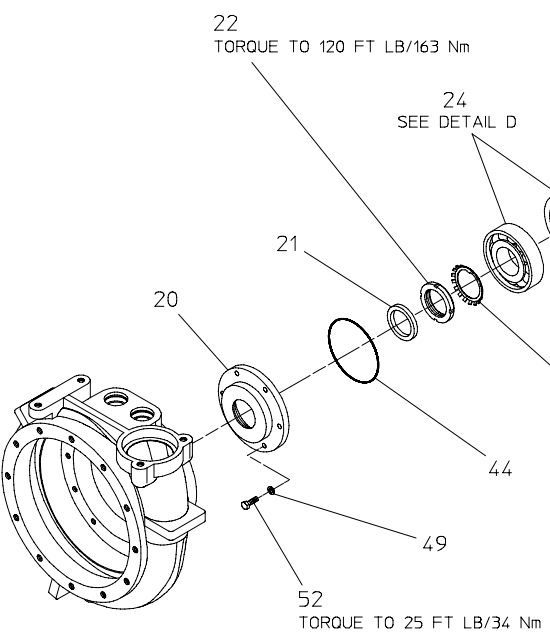
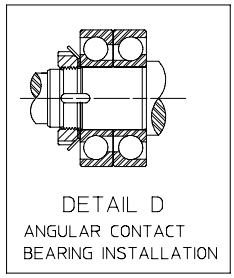
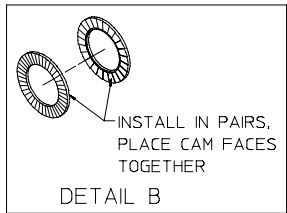
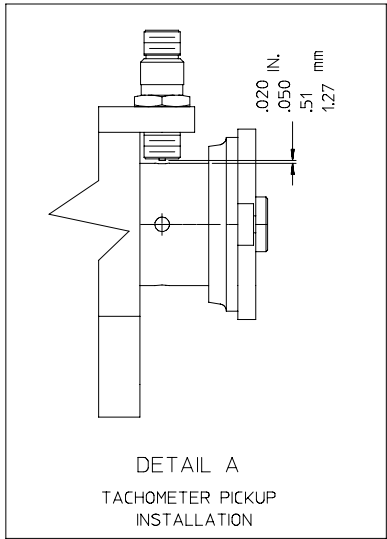

IMPELLER SHAFT & PEDESTAL ASSEMBLY

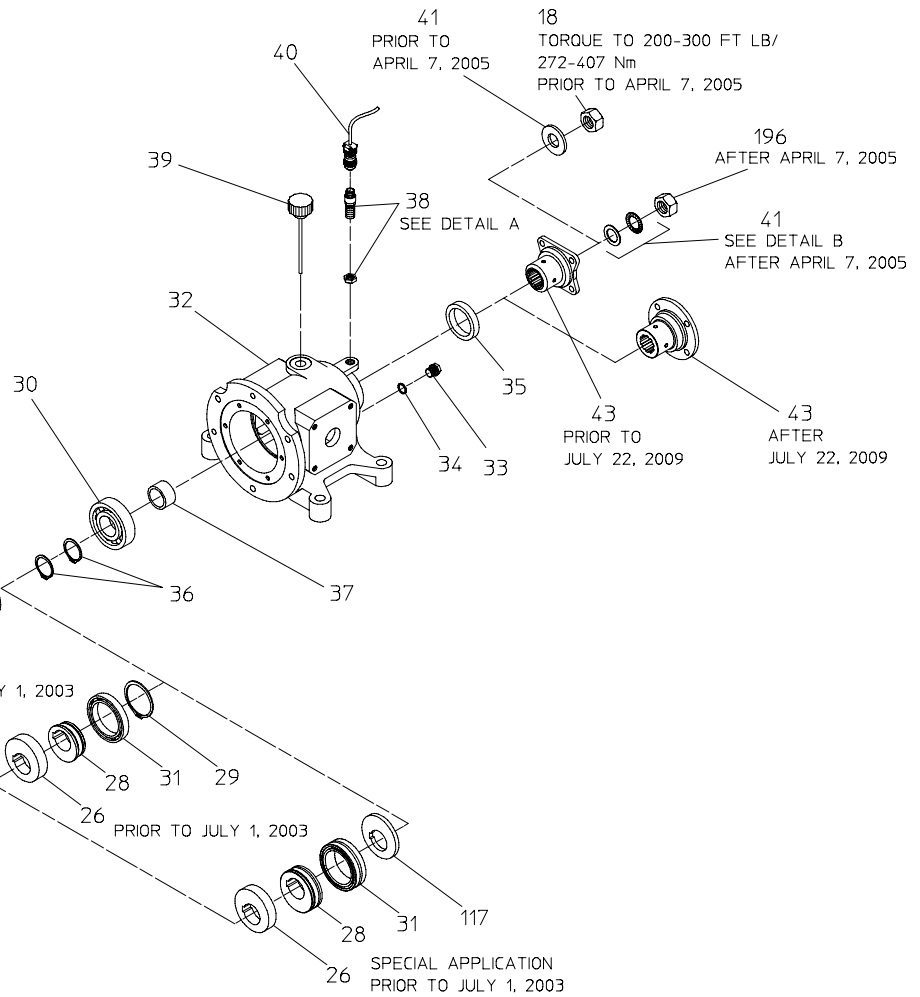

RTP Foam System (Optional) (After June 29, 2009)

REF. NO.	DESCRIPTION
8	Hex Hd Screw, M12-1.75 x 30
9	Lock Washer, 12 mm
42	Gasket / Shim / O-ring Replacement Kit
49	Lock Washer, 8 mm
53	Hex Hd Screw, M8-1.25 x 45
91	O-ring, 4-1/2 x 4-3/4 in.
96	O-ring, 1 x 1-1/4 in.
108	Square Hd Pipe Plug, 1 NPT
122	Eductor Body
123	Eductor Nozzle
124	Ball Valve, 1/2 NPT
125	On/Off Valve
126	Panel Plate
127	Pointer

REF. NO.	DESCRIPTION
130	Foam Tube
132	Close Nipple, 1/2 NPT x 1-1/8 in.
133	Reducing Bushing, 1 NPT x 1/2 NPT
138	Socket Hd Screw, M5-0.8 x 6
139	Tee, 1 NPT
143	PVC Tubing, 48 in.
144	Wand
145	One Ear Hose Clamp, 1-3/8 in.
146	Standard Nipple, 1 NPT (m) x 1 Hose (m)
148	Foam Tube Bushing
221	Pipe Nipple, 3/4 NPT x 1-3/8 in.
222	Street Elbow, 90 Degrees, 3/4 NPT
223	Reducing Bushing, 1-1/4 NPT x 3/4 NPT
224	Reducing Bushing, 1 NPT x 3/4 NPT

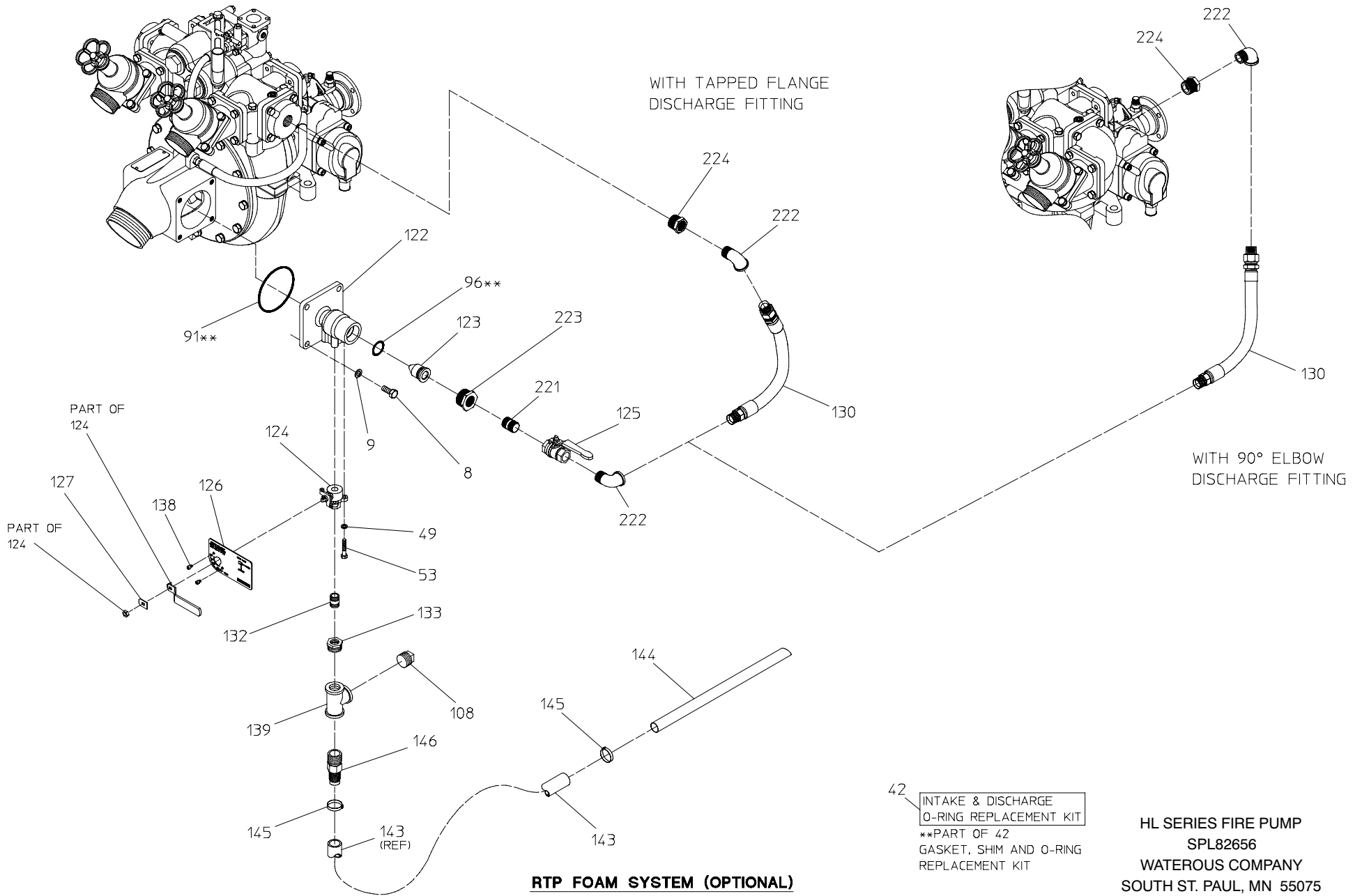

RTP FOAM SYSTEM (OPTIONAL)

AFTER JUNE 29, 2009

**HL SERIES FIRE PUMP
SPL82656
WATEROUS COMPANY
SOUTH ST. PAUL, MN 55075**

RTP Foam System (Optional)
(Prior to June 29, 2009)

REF. NO.	DESCRIPTION
8	Hex Hd Screw, M12-1.75 x 30
9	Lock Washer, 12 mm
42	Gasket / Shim / O-ring Replacement Kit
49	Lock Washer, 8 mm
53	Hex Hd Screw, M8-1.25 x 45
91	O-ring, 4-1/2 x 4-3/4 in.
96	O-ring, 1 x 1-1/4 in.
108	Square Hd Pipe Plug, 1 NPT
122	Eductor Body
123	Eductor Nozzle
124	Ball Valve, 1/2 NPT
125	On/Off Valve
126	Panel Plate
127	Pointer

REF. NO.	DESCRIPTION
128	Male Elbow, 1 NPT x 1 Tube
129	Male Connector, 1 NPT x 1 Tube
130	Foam Tube
131	Reducing Bushing, 1-1/4 NPT x 1 NPT
132	Close Nipple, 1/2 NPT x 1-1/8 in.
133	Reducing Bushing, 1 NPT x 1/2 NPT
138	Socket Hd Screw, M5-0.8 x 6
139	Tee, 1 NPT
143	PVC Tubing, 48 in.
144	Wand
145	One Ear Hose Clamp, 1-3/8 in.
146	Standard Nipple, 1 NPT (m) x 1 Hose (m)
148	Foam Tube Bushing

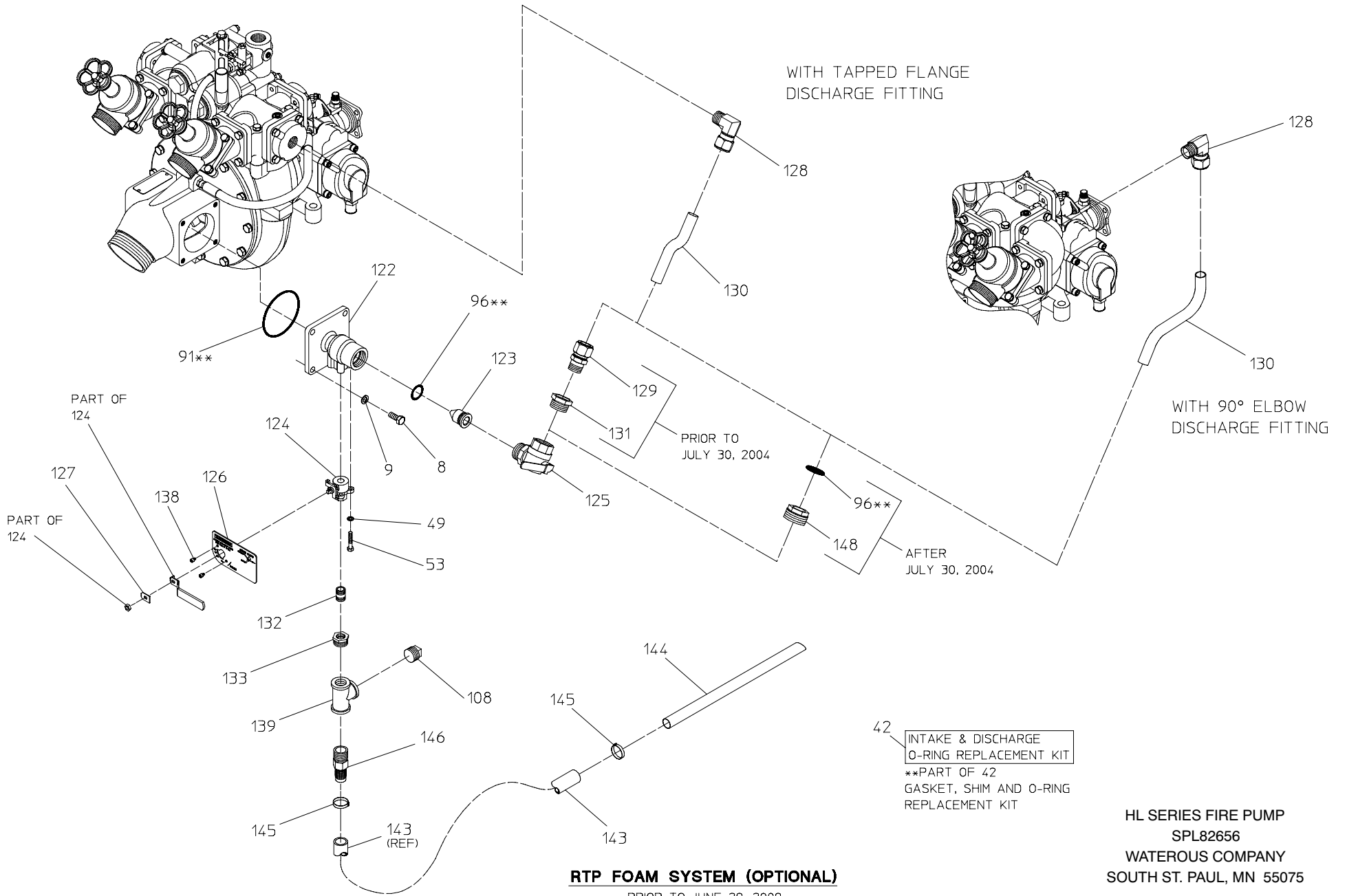

RTP FOAM SYSTEM (OPTIONAL)

PRIOR TO JUNE 29, 2009

42 INTAKE & DISCHARGE
O-RING REPLACEMENT KIT
**PART OF 42
GASKET, SHIM AND O-RING
REPLACEMENT KIT

Control Panel

REF. NO.	DESCRIPTION
174	Manual Control Panel Without Monitor
174	Manual Control Panel With Water Tank Level Monitor
174	Manual Control Panel With Water and Foam Tank Level Monitors
175	Elbow Fitting, 6 mm Tube x 1/4 BSPT
177	Straight Fitting, 6 mm Tube x 1/4 BSPT
178	Reducing Bushing, 1/4 BSPT (F) x 1/2 NPT (M)
179	Temperature Switch
180	Pump Engaged Wiring Harness (Green LED)
181	Blue Nylon Tube, 6 mm x 12 in.
182	Elbow Fitting, 6 mm Tube x 1/4 NPT (Stainless Steel)
183	Elbow Fitting, 6 mm Tube x 1/4 NPT (Brass)
184	High Temperature Switch Wiring Harness (Red LED)
185	Tube, 6 mm (Stainless Steel)
199	Tachometer Wiring Harness

REF. NO.	DESCRIPTION
200	Control Panel Mounting Bracket
204	Elbow Fitting, 1/4 BSPT x 1/4 NPT
205	Level Monitor Wiring Harness
206	Tank Level Sender
207	Master Water Display
208	Dual Master Water/Foam Display
210	Bulb, 12 Volt or 24 Volt
211	Tachometer/Hour Meter Gauge
212	Compound Gauge
213	High Pressure Gauge
214	Normal Pressure Gauge
215	Blue Nylon Tube, 6 mm x 24 in.
219	Indicator Module (Green LED)
220	Indicator Module, (Red LED)

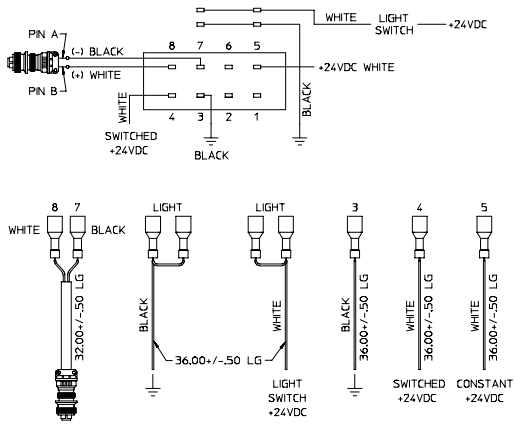

TACHOMETER WIRING SCHEMATIC

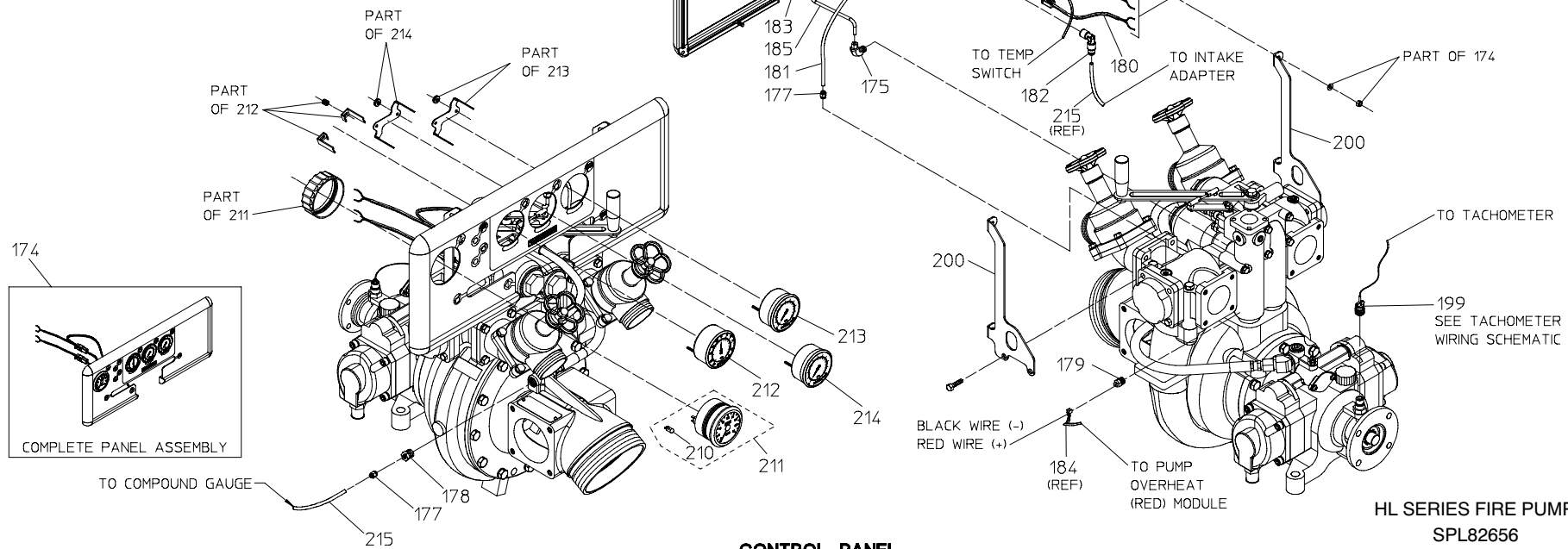
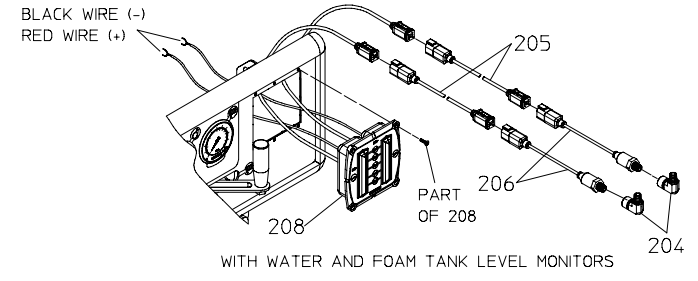
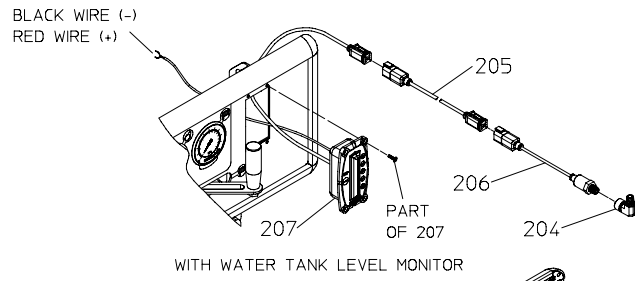

HL SERIES FIRE PUMP
 SPL82656
 WATEROUS COMPANY
 SOUTH ST. PAUL, MN 55075
 PAGE 23 OF 27

Optional Items

REF. NO.	DESCRIPTION
55	Tachometer/Hourmeter, 12 or 24 Volt
171	Pump Panel Instrument Package
172	Water Tank Level Monitor
173	Dual Water/Foam Level Monitor
204	90° Elbow, 1/4 BSPT x 1/4 NPT
205	Wiring Harness, 20 Foot
206	Tank Sender

REF. NO.	DESCRIPTION
207	Master Water Display
208	Dual Master Water/Foam Display
210	Bulb, 12 or 24 Volt
211	Tachometer/Hour Meter Gauge
212	Compound Gauge
213	High Pressure Gauge
214	Normal Pressure Gauge

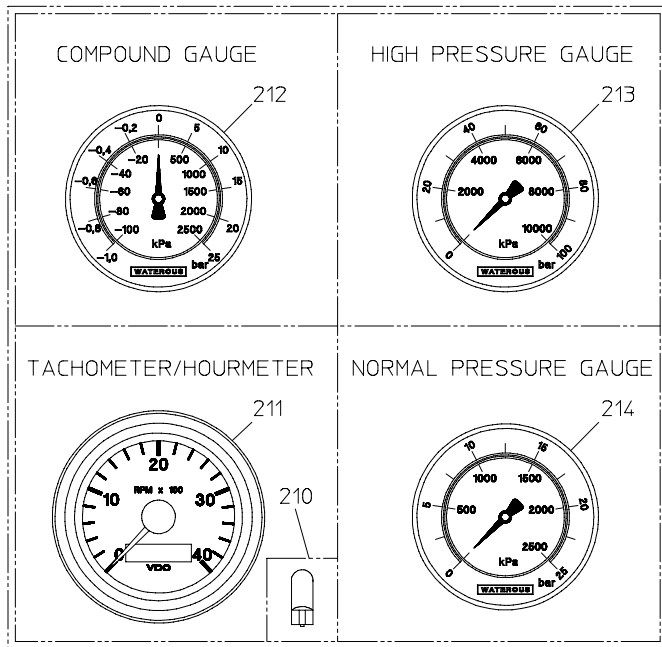

PUMP PANEL INSTRUMENT PACKAGE

171

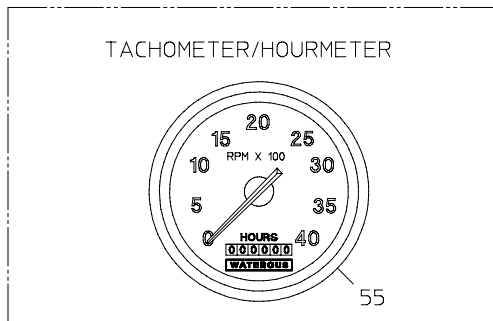

55

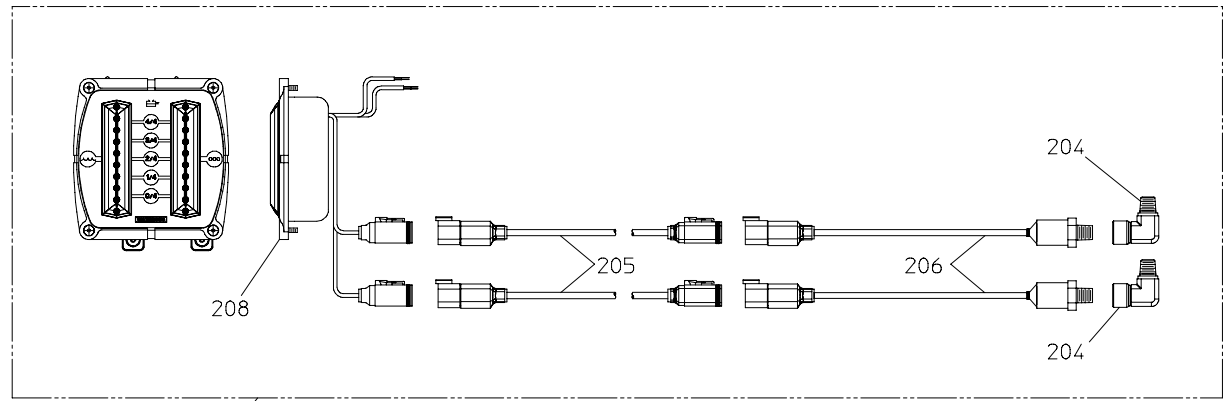

DUAL WATER/FOAM TANK LEVEL MONITOR

173

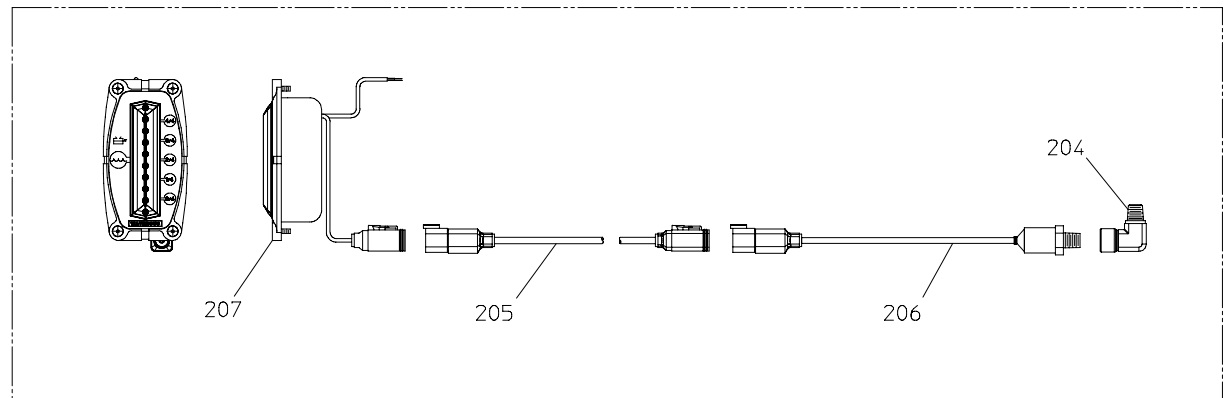

WATER TANK LEVEL MONITOR

172

OPTIONAL ITEMS

Cross-Sectional View of Pump

REF. NO.	DESCRIPTION
1	Volute Body Subassembly
2	Impeller
3	Separator Plate Subassembly
4	Main Stage Impeller
5	Mechanical Seal
6	O-ring, 2-1/2 x 2-3/4 in.
7	Headless Pipe Plug, 3/8 BSP
8	Hex Hd Screw, M12-1.75 x 30
9	Lock Washer, 12 mm
11	Wear Ring
12	Socket Hd Screw, M12-1.75 x 55
13	Lock Washer, 12 mm
15	Rectangular Key, 8 mm x 12 mm x 65 mm
16	O-ring, 2 x 2-3/16 in.
17	O-ring, 13/16 x 15/16 in.
18	Lock Nut, M24-3
19	Nord-Lock ® Washer, 24 mm
20	Oil Seal Housing
21	Oil Seal
22	Bearing Lock Nut
23	Bearing Lock Washer
24	Angular Contact Ball Bearing
25	Impeller Shaft

REF. NO.	DESCRIPTION
26	Primer Counterweight
27	Rectangular Key, 8 mm x 12 mm x 30 mm (Used prior to July 1, 2003)
27	Rectangular Key, 8 mm x 12 mm x 46 mm (Used prior to July 1, 2003)
27	Rectangular Key, 8 mm x 12 mm x 55 mm (Used After to July 1, 2003)
28	Primer Eccentric
30	Single Row Ball Bearing
31	Single Row Ball Bearing
32	Pedestal Body
33	Hex Drain Plug
34	Copper Flat Washer, 5/8 in.
35	Oil Seal
36	Retaining Ring
37	Impeller Shaft Spacer
38	Magnetic Tachometer Pick Up
39	Dip Stick
41	Nord-Lock ® Washer, 24 mm (Used After April 7, 2005)
43	Companion Flange
44	O-ring, 4-3/4 x 4-7/8 in.
49	Lock Washer, 8 mm
52	Hex Hd Screw, M8-1.25 x 25
68	Shim Pack (Includes (2) 0.003, 0.0005, 0.010 and 0.020 in. Thick Shims)
86	Intake Adapter Subassembly
89	O-ring, 11 x 11-3/8 in.
90	Outboard Bearing
196	Hex Nut, M24-3 (Used After April 7, 2005)
203	Intake Screen
239	Headless Pipe Plug, 3/4 NPT

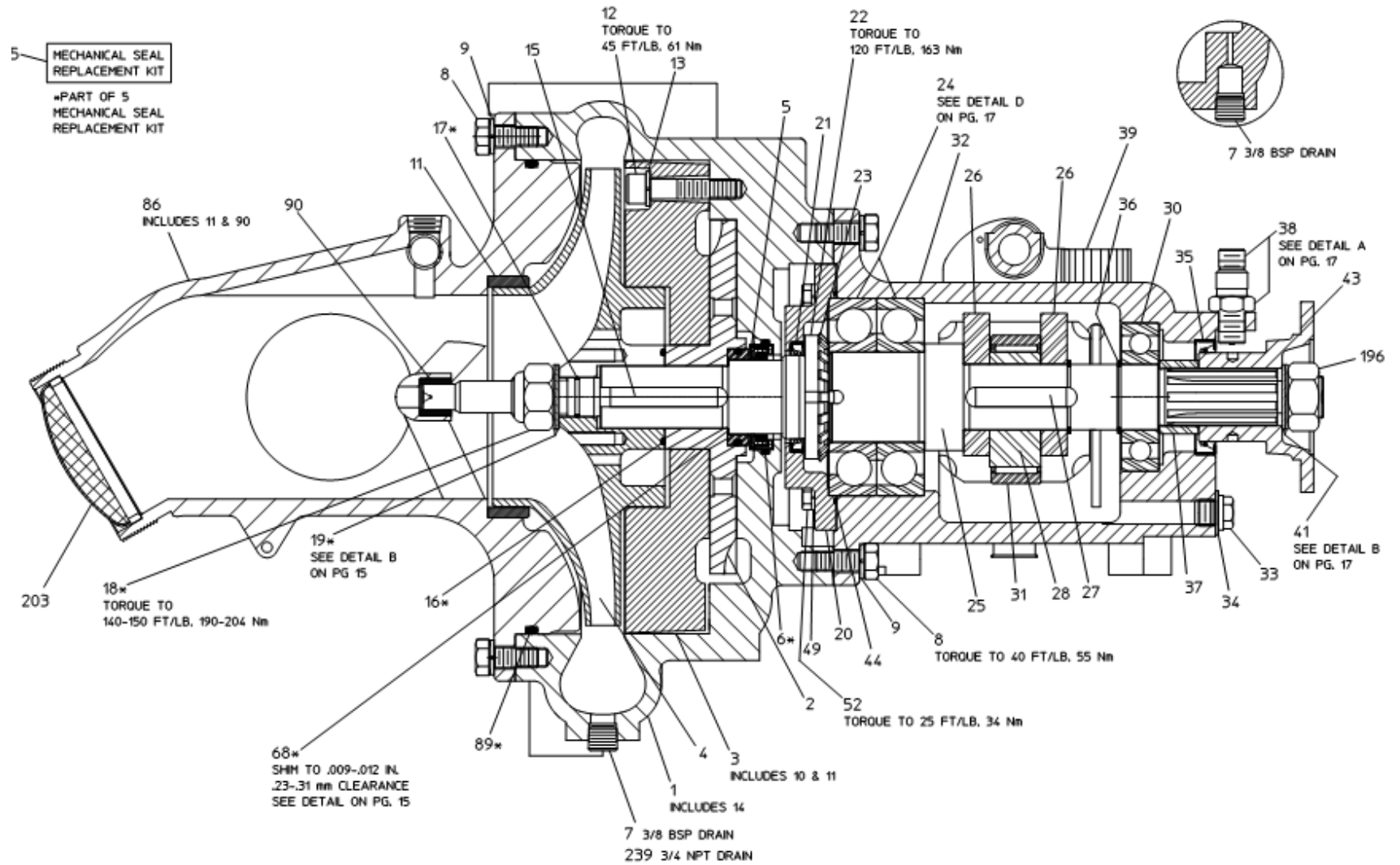

CROSS-SECTION VIEW OF PUMP