



Document Number SPL82890	Issue Date 02/13/06	Rev. Date 10/29/19
------------------------------------	-------------------------------	------------------------------

Model VPO and VPOS Priming Pump Service Parts List

Configuration as used with VAP Priming Valves

Index:

Priming Pump			Pump Transmission or P.T.O. Model <i>(Located on Serial Plate)</i>				See Page						
Model	Mounting Location		Pump Transmission		P.T.O.		Mounting	Priming Pump Components		Panel Switch and Wiring		Prime-Safe™ Lubricant	
			Series	Model	Series	Model		Exploded View	Cross-Section View	Standard Push-Button Switch	Optional Oversize Push-Button Switch	Configuration when Used	Configuration when Not Used
VPO	On Pump Transmission or P.T.O.		C20	C20B	TC20	TC20B	2, 3 or 4, 5*	12, 13	14, 15	16, 17	20, 21 or 22, 23	24, 25	24, 25
				C20C		TC20C							
			C20D	TC20D									
			C20E	TC20E									
			C20F	TC20F									
			C21	C21	-	-							
C10	C10B	TC10	TC10B	6, 7									
	C10C		TC10C										
C10D	TC10D												
C10E	TC10E												
C10F	TC10F												
Y	YB, YBX YC, YCX YD, YDX YE, YEX YF, YFX	TY	TYB, TYBX TYC, TYCX TYD, TYDX TYE, TYEX TYF, TYFX										
QC	QC	-	-	8, 9									
W	WB WBX	-	-	10, 11									
VPOS	Separately Mounted (Not on Transmission or P.T.O.)	Single Pump	All				-	12, 13	14, 15	18, 19	-	24, 25	24, 25
		Dual Pumps	All				-						

*Note: Pages 4 and 5 apply to TC20 Series PTO's with Eclipse ES™ only.

Model VPO

Mounting on C20 and C21Series Transmissions and TC20 and TC21Series P.T.O.'s

REF. NO.	DESCRIPTION
K12	Primer Sub-assembly
K13	Mounting Bracket
K16	Lock Washer, 3/8 in.

REF. NO.	DESCRIPTION
K17	Socket Hd Screw, 5/16-18 x 1 in.
K18	Lock Washer 5/16 in.
K28	Cable Extension
K34	Hex Hd Screw, 3/8-16 x 1 in.

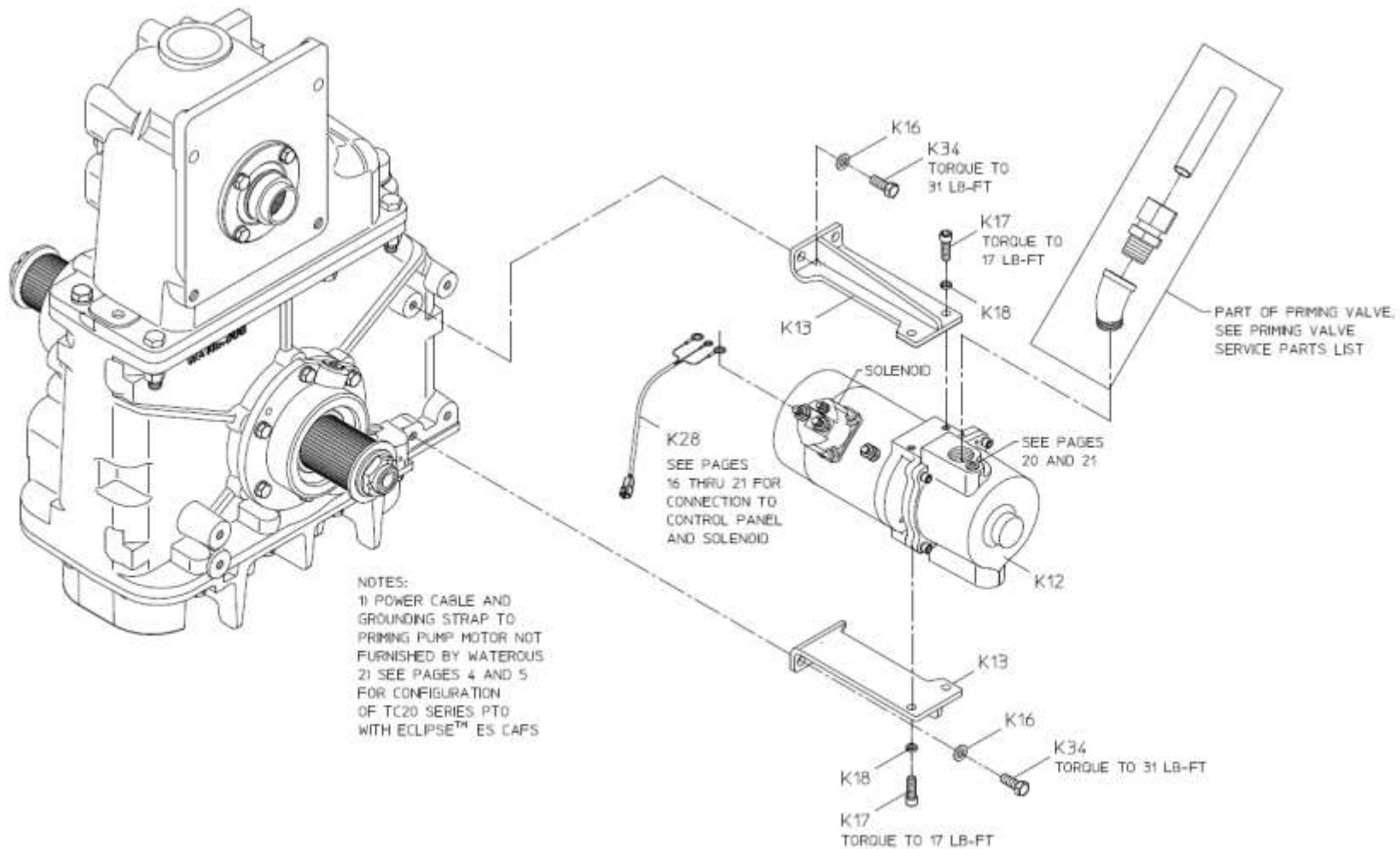

MODEL VPO MOUNTING ON
C20 AND C21 SERIES TRANSMISSIONS
AND TC20 AND TC21 SERIES PTO'S

Model VPO

Mounting on TC20 Series P.T.O.'s with Eclipse ES CAFS

REF. NO.	DESCRIPTION
K12	Primer Sub-assembly
K13	Mounting Bracket
K15	Hex Hd Screw, 3/8-16 x 1-1/4 in.
K16	Lock Washer, 3/8 in.

REF. NO.	DESCRIPTION
K17	Socket Hd Screw, 5/16-18 x 1 in.
K18	Lock Washer 5/16 in.
K28	Cable Extension
K35	Bottom Mounting Bracket Spacer

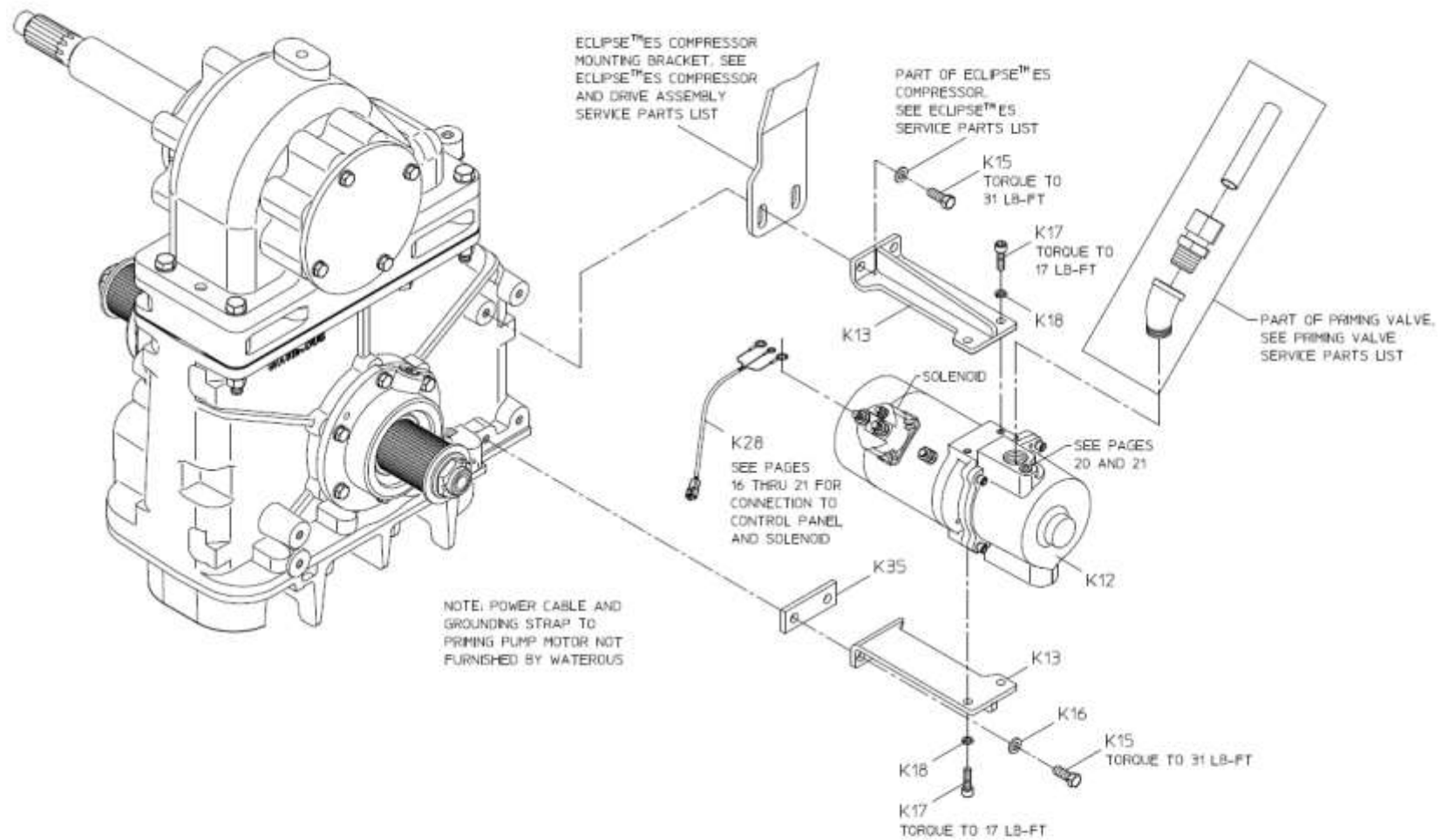

MODEL VPO MOUNTING ON
TC20 SERIES PTO WITH ECLIPSE™ ES CAFS

Model VPO

Mounting on Y, C10 Series Transmissions and TY, TC10 Series P.T.O.'s

REF. NO.	DESCRIPTION
K12	Primer Sub-assembly
K13	Mounting Bracket
K14	Bottom Mounting Bracket
K15	Hex Hd Screw Y and TY Series: 3/8-16 x 1-1/4 in. C10 and TC10 Series: M10 x 30mm (Prior to June 25, 2002) M10 x 20mm (After June 25, 2002)

REF. NO.	DESCRIPTION
K16	Lock Washer, 3/8 in.
K16	Lock Washer, M10
K17	Socket Hd Screw, 5/16-18 x 1 in.
K18	Lock Washer 5/16 in.
K28	Cable Extension

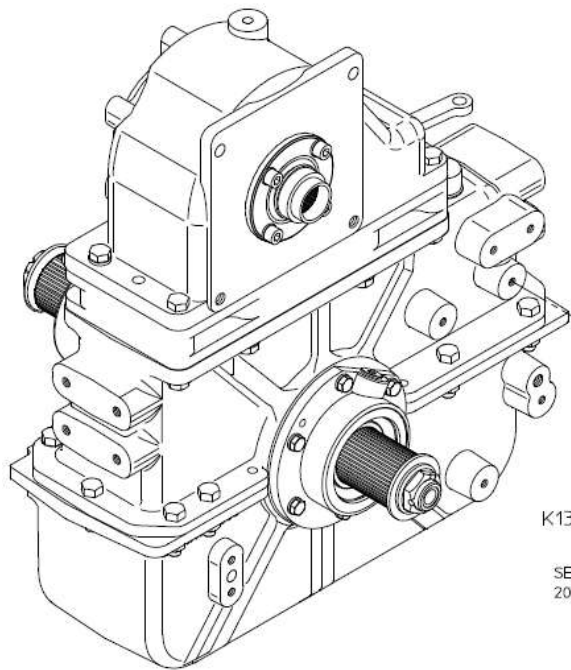

NOTE: POWER CABLE AND
GROUNDING STRAP TO
PRIMING PUMP MOTOR NOT
FURNISHED BY WATEROUS

MODEL VPO MOUNTING ON
Y SERIES AND C10 SERIES TRANSMISSIONS
AND TY SERIES, TC10 SERIES PTO'S

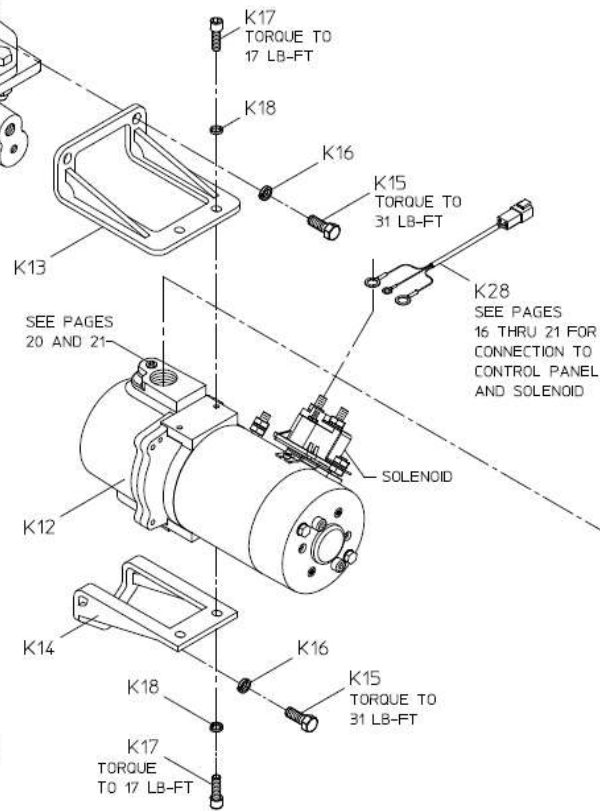

PART OF PRIMING VALVE,
SEE PRIMING VALVE
SERVICE PARTS LIST

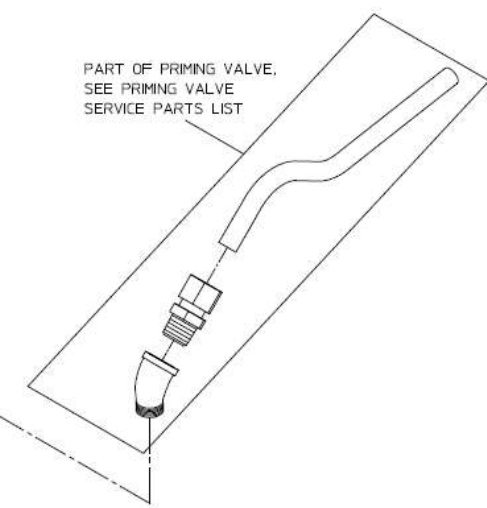

Model VPO
Mounting on QC Series Transmission

REF. NO.	DESCRIPTION
K12	Primer Sub-assembly
K15	Hex Hd Screw 3/8-16 x 1-1/4 in.
K16	Lock Washer, 3/8 in.
K17	Socket Hd Screw, 5/16-18 x 1 in.
K18	Lock Washer 5/16 in.
K 28	Cable Extension

REF. NO.	DESCRIPTION
K34	Hex Hd Screw, 3/8-16 x 1 in.
K36	Lower Primer Bracket
K37	Upper Primer Bracket
K38	3/4 NPT x 3/4 Tubing Fitting

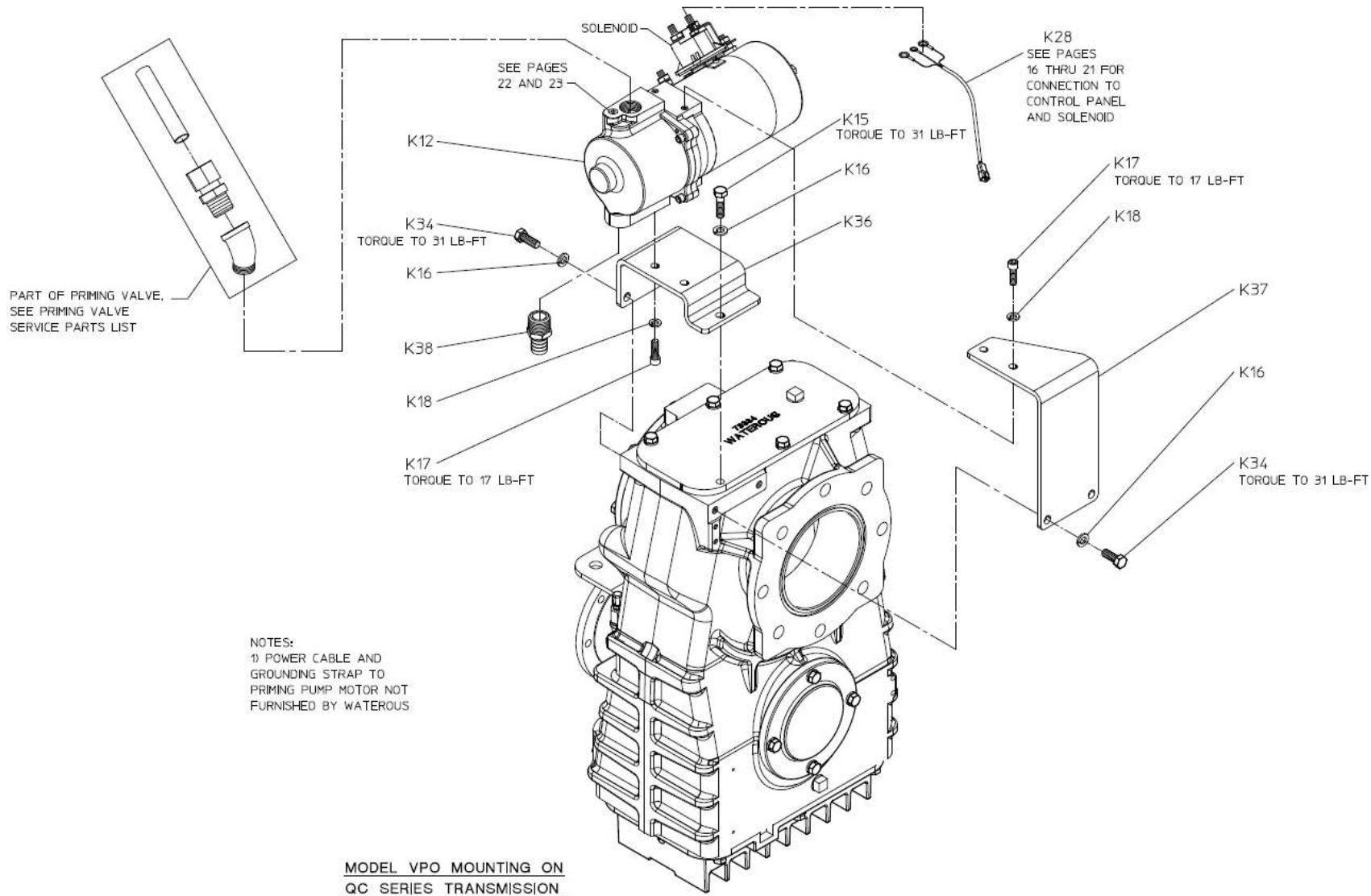

Model VPO
Mounting on W Series Transmissions

REF. NO.	DESCRIPTION
K12	Primer Sub-assembly
K13	Mounting Bracket
K14	Bottom Mounting Bracket
K15	Hex Hd Screw, 3/8-16 x 1-1/4 in.

REF. NO.	DESCRIPTION
K16	Lock Washer, 3/8 in.
K17	Socket Hd Screw, 5/16-18 x 1 in.
K18	Lock Washer 5/16 in.
K28	Cable Extension

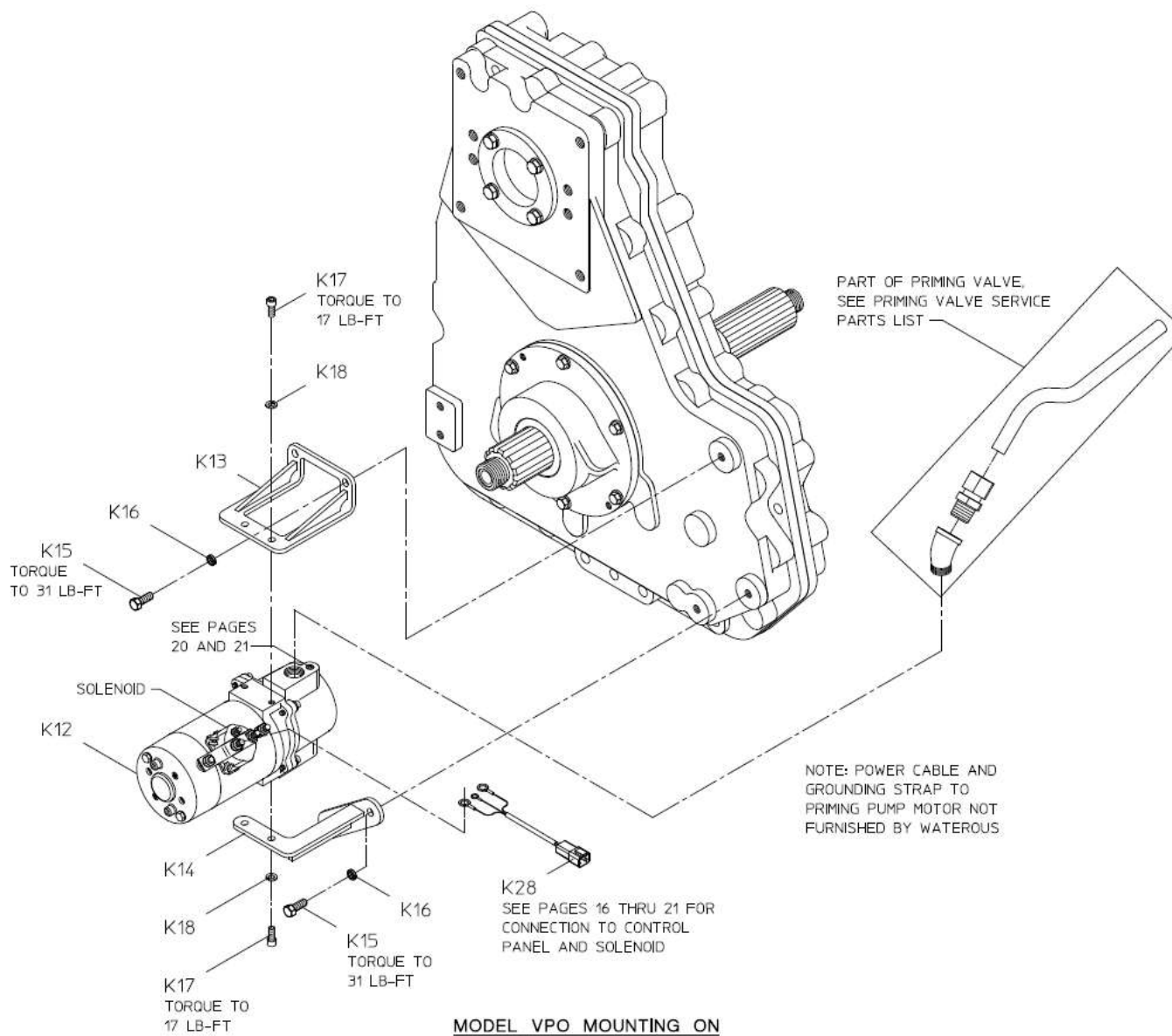

**MODEL VPO MOUNTING ON
W SERIES TRANSMISSIONS**

Priming Pump Components

Models VPO and VPOS (Exploded View)

REF. NO.	DESCRIPTION
K1	Vane
K2	Oilite Bearing
K3	Rotor Assembly (Includes Shaft)
K4	Adapter Assembly, (Includes K2, K6 and K8)
K5	Motor Assembly (Includes K2, K4, K6, K8, K23 and (2) 1/4-20 x 6-1/2 in. Hex Hd Mounting Screws)
K6	O-ring, .612 x .818 in.
K7	O-ring, 3.859 x 4.137 in.
K8	Dowel Pin, 3/15 x 3/4 in.

REF. NO.	DESCRIPTION
K10	Housing Assembly (Includes K2)
K12	Primer Sub-assembly
K19	Repair Kit
K21	Socket Hd Screw, 1/4-20 x 1 in.
K22	Lock Washer, 1/4 in.
K23	Solenoid
K24	Wire Clamp

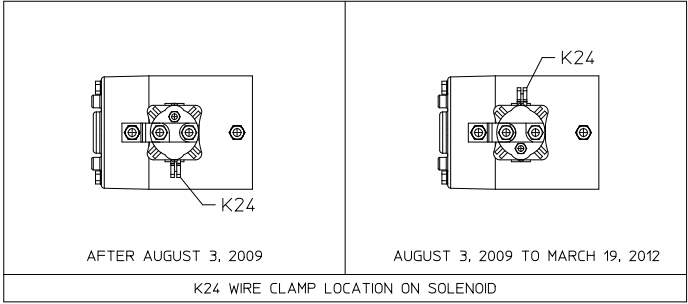
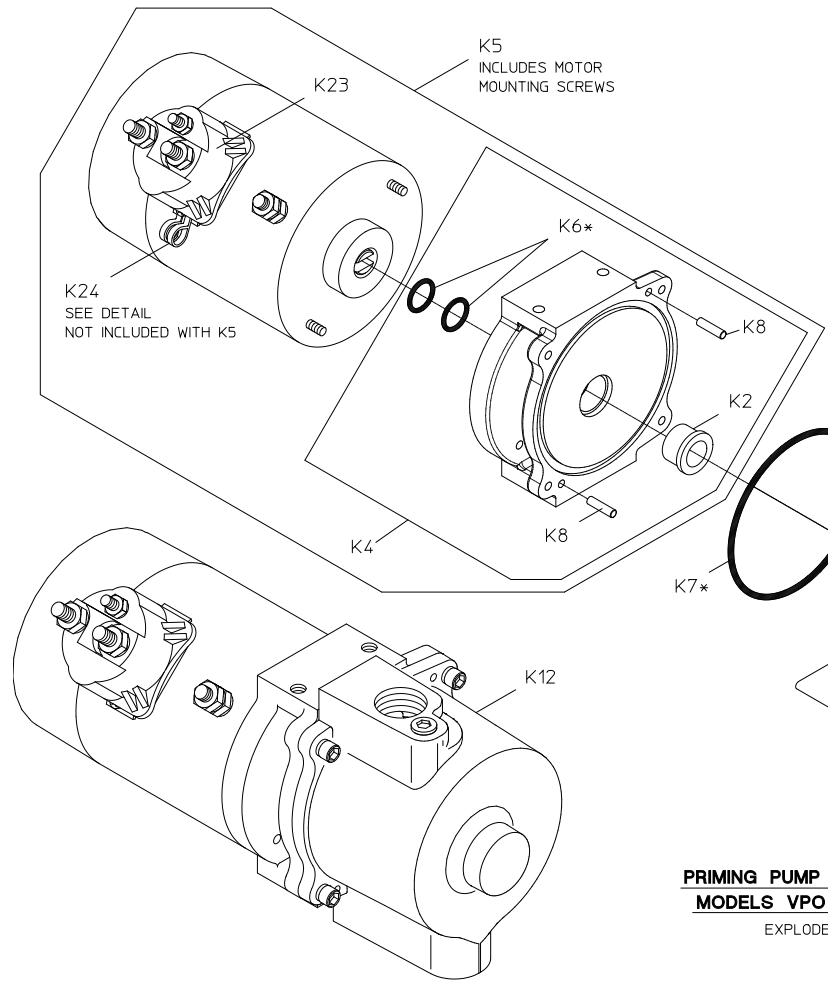

REPAIR KIT
 K19
 * COMPONENT OF REPAIR KIT

PRIMING PUMP COMPONENTS
MODELS VPO AND VPOS
 EXPLODED VIEW

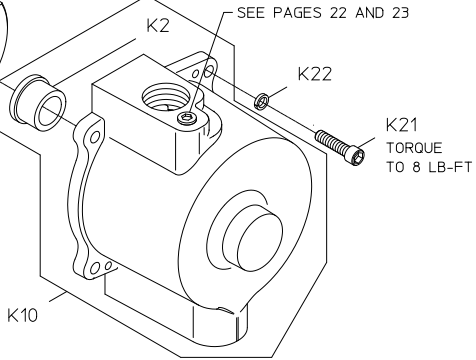

Priming Pump Components

Models VPO and VPOS (Cross-Section View)

REF. NO.	DESCRIPTION
K1	Vane
K2	Oilite Bearing
K3	Rotor Assembly (Includes Shaft)
K4	Adapter Assembly, (Includes K2, K6 and K8)
K5	Motor Assembly (Includes K2, K4, K6, K8, K23 and(2) 1/4-20 x 6-1/2 in. Hex Hd Mounting Screws)
K6	O-ring, .612 x .818 in.
K7	O-ring, 3.859 x 4.137 in.
K8	Dowel Pin, 3/15 x 3/4 in.

REF. NO.	DESCRIPTION
K10	Housing Assembly (Includes K2)
K21	Socket Hd Screw, 1/4-20 x 1 in.
K22	Lock Washer, 1/4 in.
K23	Solenoid
K24	Wire Clamp

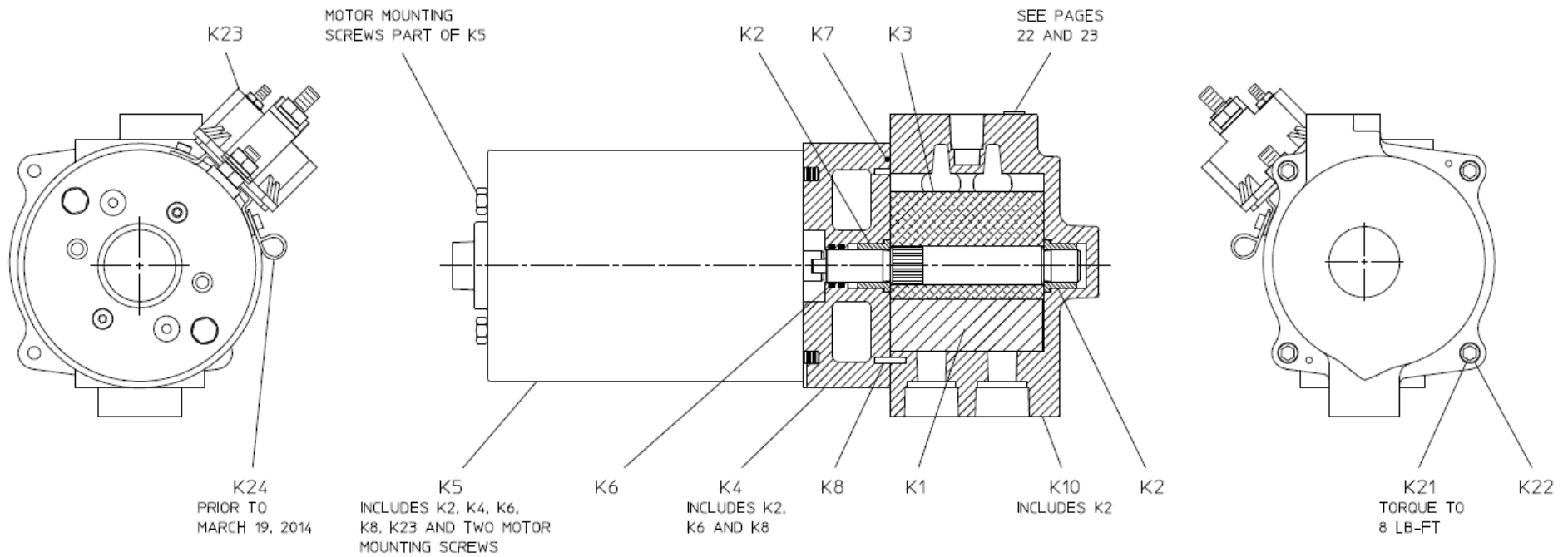

PRIMING PUMP COMPONENTS
MODELS VPO AND VPOS
 CROSS-SECTION VIEW

Panel Switch and Wiring
Single Primer Push-Button Switch

REF. NO.	DESCRIPTION
K20	Control Panel with Integral Switch (Includes K29 Mounting Screw and Nuts)
K28	Cable Extension

REF. NO.	DESCRIPTION
K29	Flat Hd Screw, 6-32 x 3/4 in. and 6-32 Hex Nut (For Control Panel)

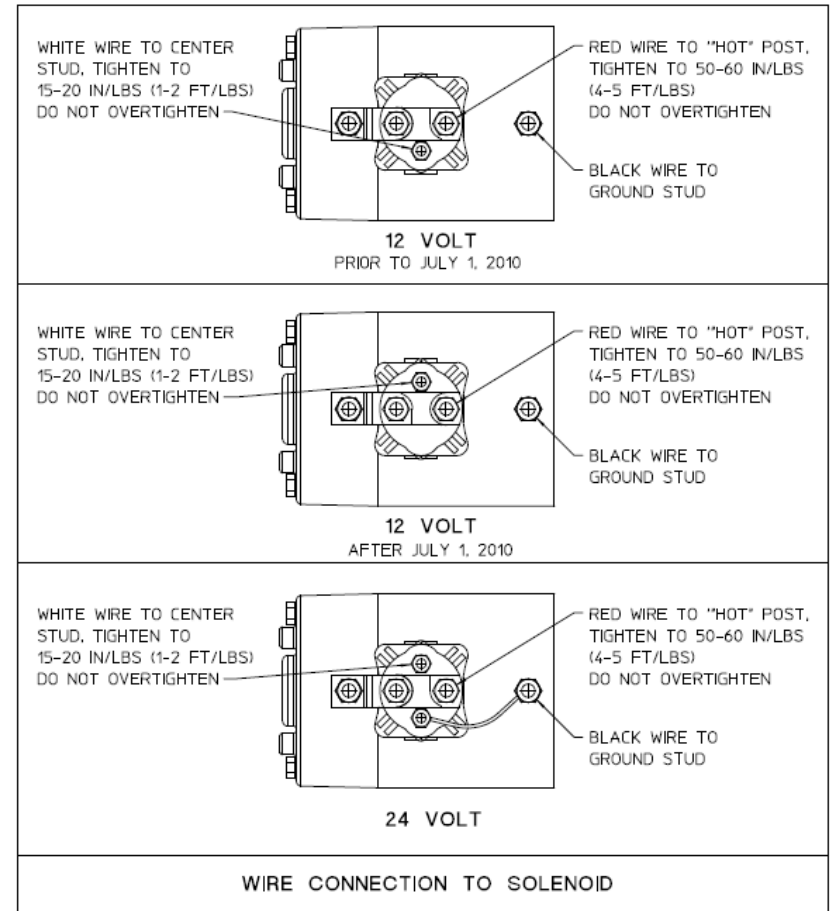
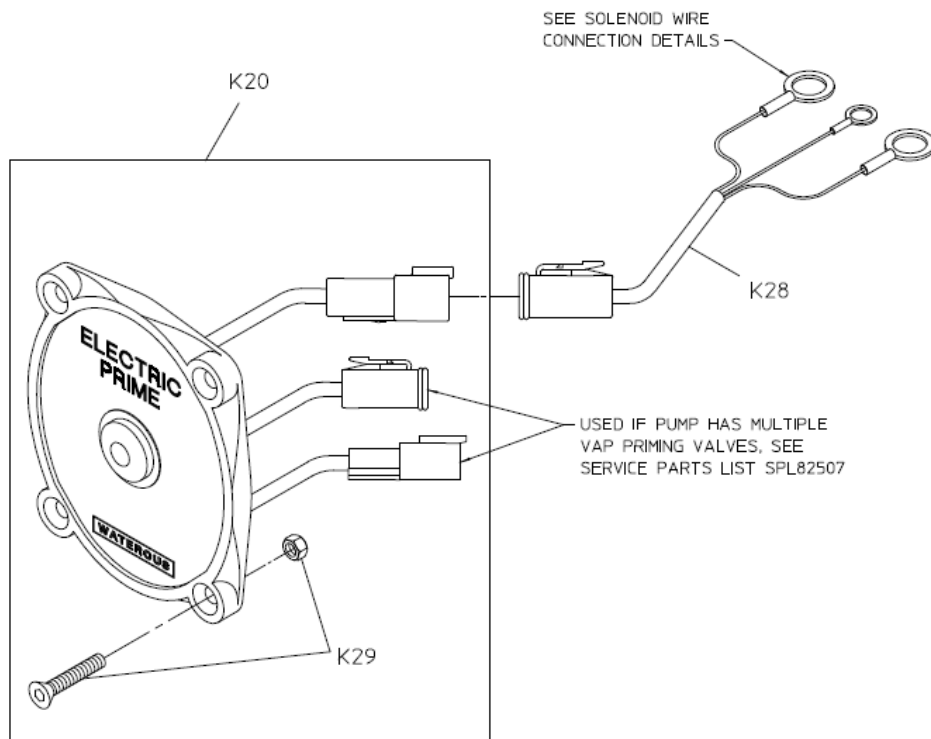

PANEL SWITCH AND WIRING
SINGLE PRIMER
 STANDARD PUSH-BUTTON SWITCH

Panel Switch and Wiring
Dual Primer Push-Button Switch

REF. NO.	DESCRIPTION
K20	Control Panel with Integral Switch (Includes K29 Mounting)
K28	Cable Extension

REF. NO.	DESCRIPTION
K29	Flat Hd Screw, 6-32 x 3/4 in. and 6-32 Hex Nut (For Control Panel)
K40	Jumper Wire

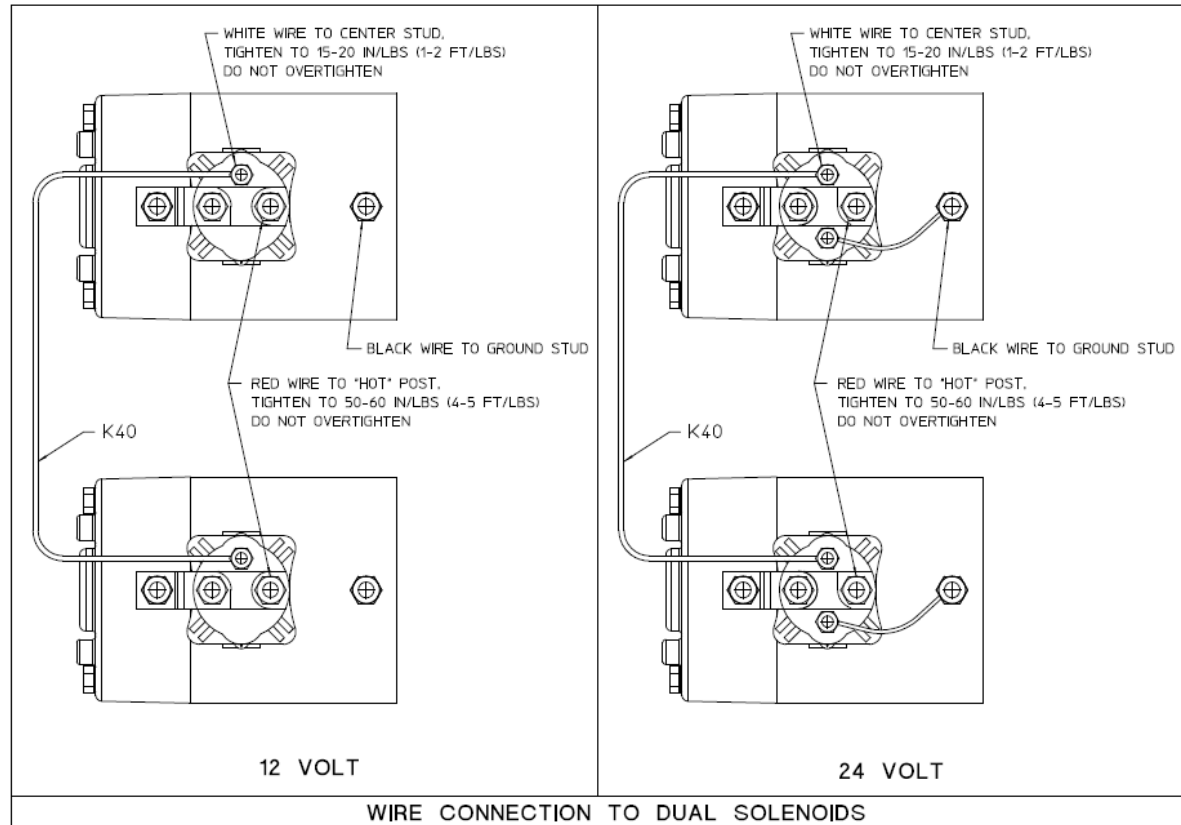
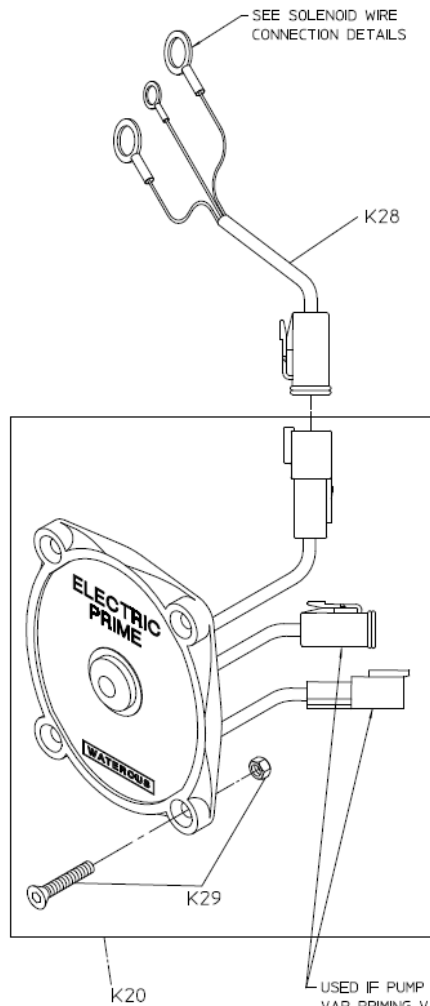

PANEL SWITCH AND WIRING
DUAL PRIMER
 STANDARD PUSH-BUTTON SWITCH

Panel Switch and Wiring
Optional Oversize Push-Button Switch

REF. NO.	DESCRIPTION
K 28	Cable Extension
K29	Flat Hd Screw, 6-32 x 3/4 in. and 6-32 Hex Nut (For Control Panel)

REF. NO.	DESCRIPTION
K30	Control Panel with Integral Switch (Includes K29 Mounting Screws and Nuts)

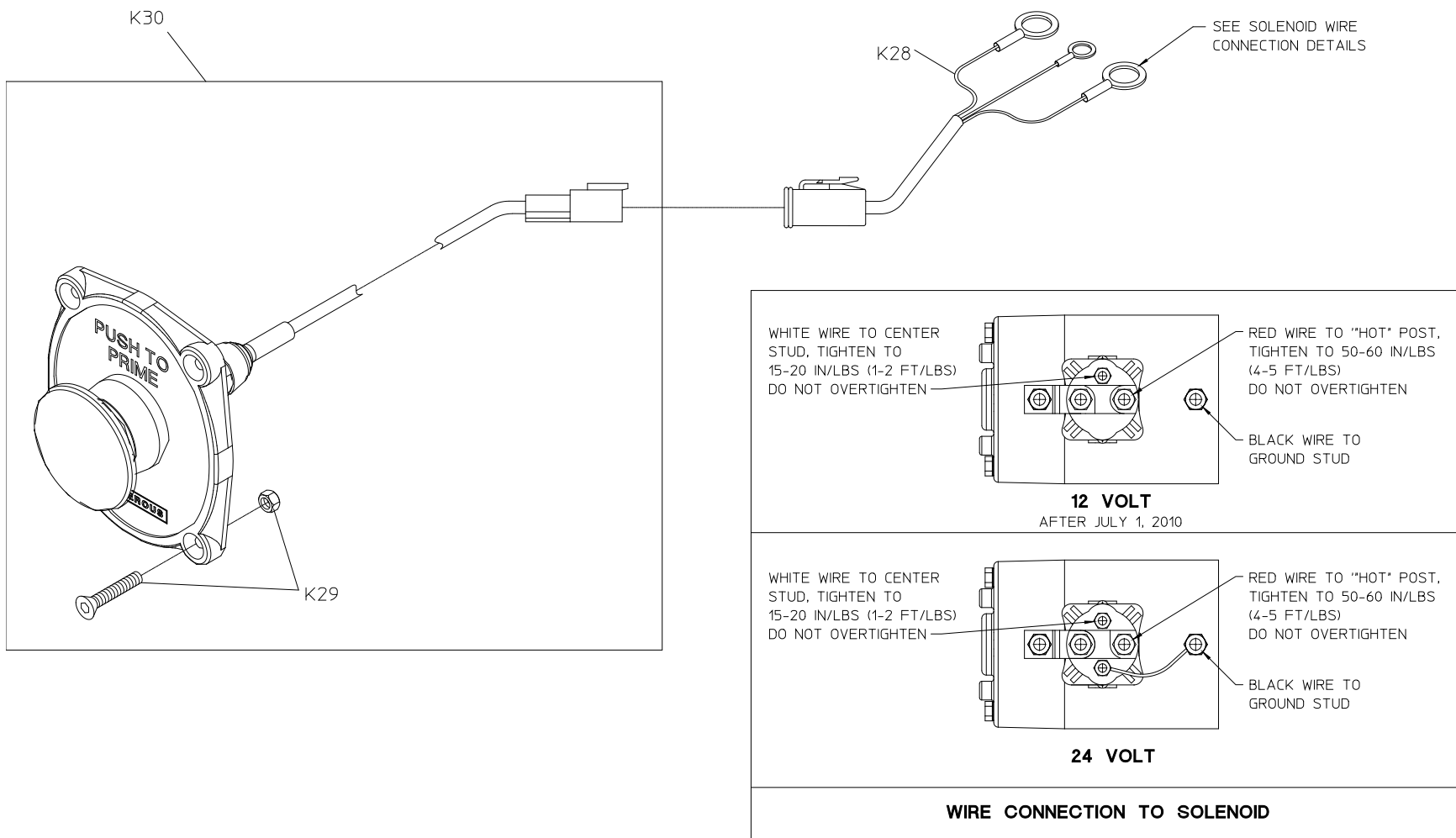

**PANEL SWITCH AND WIRING
SINGLE PRIMER**

OPTIONAL OVERSIZED PUSH-BUTTON SWITCH
AFTER JUNE 19, 2015

Panel Switch and Wiring

Optional Oversize Push Button Switch – *(September 6, 2011 to June 19, 2015)*

REF. NO.	DESCRIPTION
K29	Flat Hd Screw, 6-32 x 3/4 in. and 6-32 Hex Nut (For Control Panel)
K30	Switch Assembly
K31	Control Panel (Includes K29 Mounting Screws and Nuts)

REF. NO.	DESCRIPTION
K32	Switch Wire
K33	PVC Washer, 5/8 in.

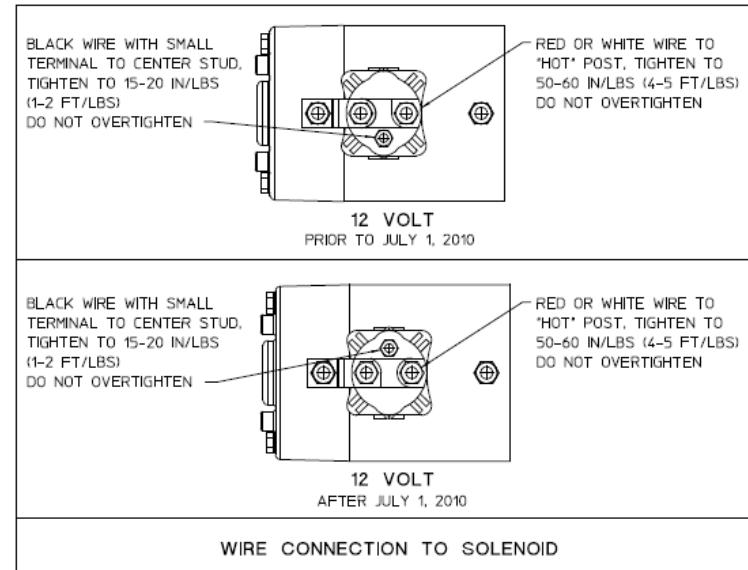
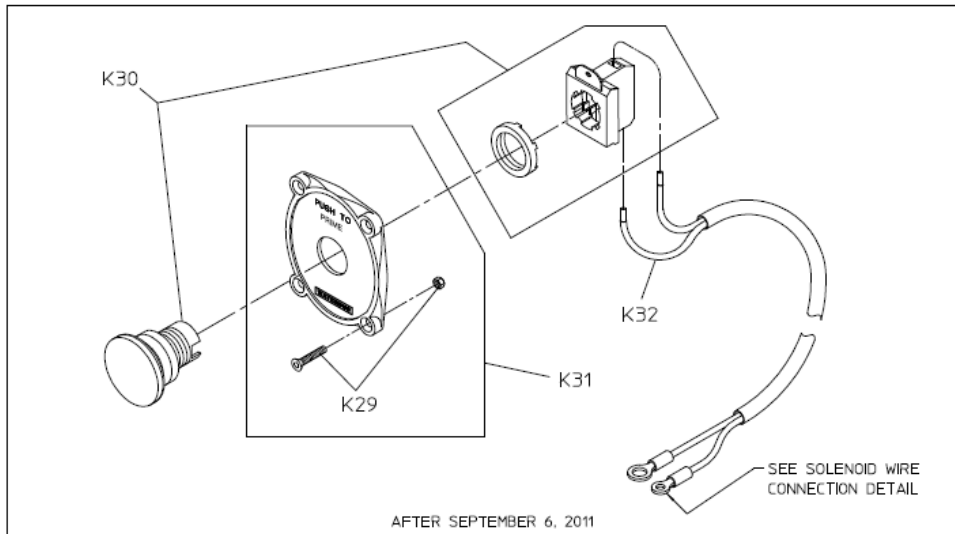
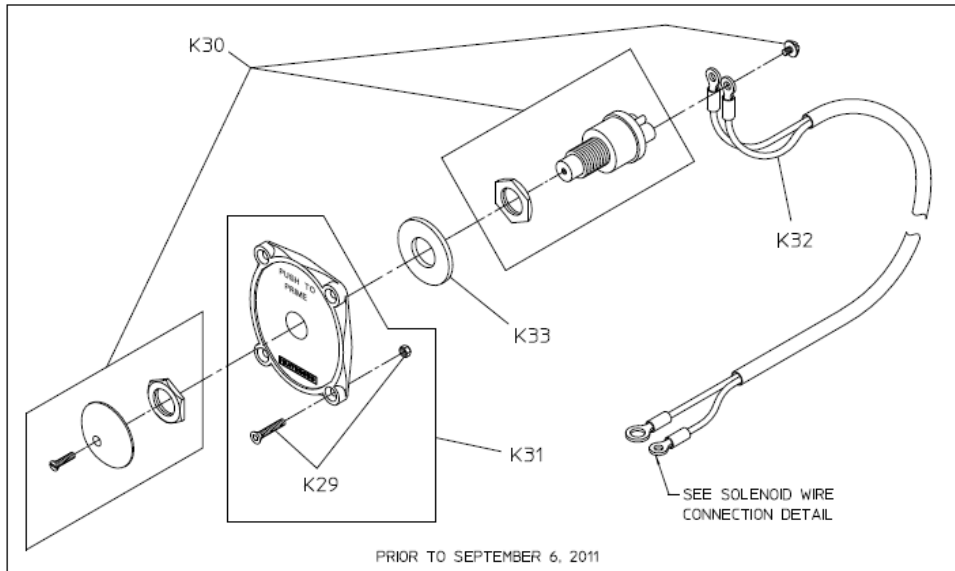

PANEL SWITCH AND WIRING
OPTIONAL OVERSIZED PUSH-BUTTON SWITCH

Prime-Safe™ Lubricant

REF. NO.	DESCRIPTION
K9	Headless Pipe Plug, 1/8 NPT
K25	Check Valve, 1/8 NPT

REF. NO.	DESCRIPTION
K26	Compression Fitting, 1/8 in.
K27	Prime-Safe™ Decal

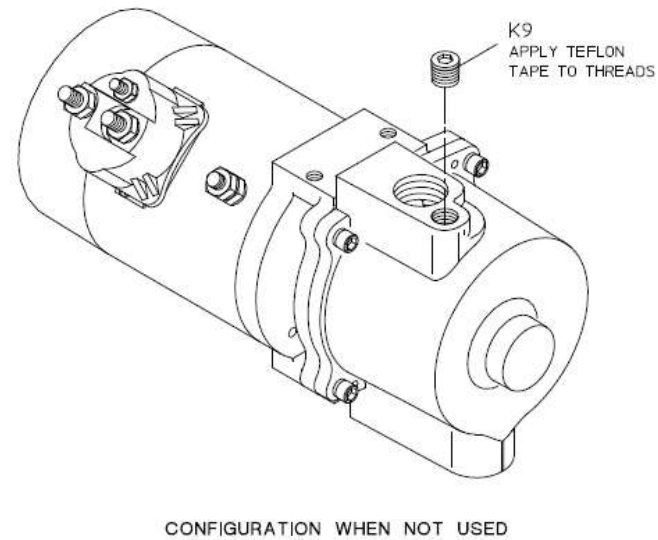
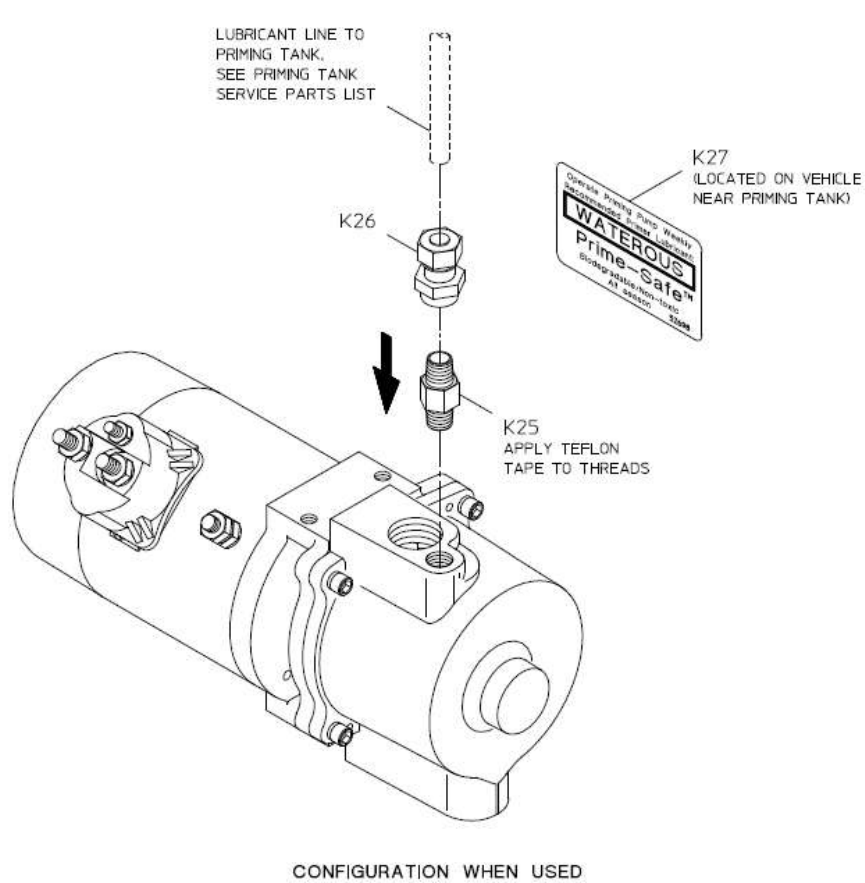

PRIME-SAFE™ LUBRICANT