



Document Number	Issue Date	Rev. Date
SPL82897	04/20/06	10/16/19

C10 Transmission Assembly Service Parts List

Index:

Components			See Page	See Page	See Page	
			CM & CS Pump Models	CG & CX Pump Models	CMH & CSH Pump Models	
Case Assembly	Viewed from Input Side		2, 3	2, 3	2, 3	
	Viewed from Output Side		4, 5	4, 5	4, 5	
	Spacers and Shims		6, 7	6, 7	6, 7	
	Hardware	Lower Section of Case	8, 9	8, 9	8, 9	
		Between Cap and Case	Model C10B	10, 11	10, 11	10, 11
			Model C10C	12, 13	12, 13	12, 13
			Models C10D, C10E, C10F	14, 15	14, 15	14, 15
Oil Cooler Option		16, 17	-	-		
Driveline	Input and Output Shaft		18, 19	18, 19	18, 19	
	Input Shaft Only		20, 21	20, 21	20, 21	
Driven Shaft and Rear Facing Configuration	Pump Impeller Shaft Type	Rear Facing Configuration	-	-	-	
	Separable Impeller Shaft (CM & CS Models)	None	22, 23	-	-	
		Eclipse™ CAFS	22, 23	-	-	
		Hydraulic Pump Adapter	24, 25	-	-	
		Combination Pump	24, 25	-	-	
		Oil Cooler	26, 27	-	-	
	Non-Separable Impeller Shaft (CG & CX Models)	None	-	26, 27	28, 29	
		Eclipse ES™ CAFS	-	28, 29	-	

Case Assembly, Viewed From Input Side of Case

REF. NO.	DESCRIPTION
T9	Lock Washer, M10
T11	Drive Shaft Housing
T27	Breather, 1/2 NPT
T28	Chain Case Subassembly
T46	Shift Shaft
T51	Heavy Spirol Pin, 5/16 x 1-3/8 in.
T53	Lock Washer, M12
T58	Magnetic Drain Plug, 3/4-16 (Includes O-ring T181)
T59	Spring Housing
T60	Heavy Spirol Pin, 1/4 x 1-1/4 in.
T61	Shift Lock Spring
T62	Shift Arm
T65	Case Cap

REF. NO.	DESCRIPTION
T69	Hex Nut, M12
T71	Hex Hd Screw, M12 x 60 mm
T99	Shim
T100	Spacer
T135	Hex Hd Screw, M10 x 25 mm
T136	Hex Hd Screw, M10 x 20 mm
T141	Gasket and Shim Repair Kit
T154	Hex Hd Screw, M12 x 35 mm
T180	Magnetic Tachometer Pickup
T181	O-ring, 5/8 x 3/4 in.
T244	Socket Hd Screw, M10 x 25 mm
T245	O-ring, 5-1/4 x 5-1/2 in.
T253	Set Screw, 5/8-18 x 5/8 in.
T257	V-ring Seal

Hardware Torque Specifications:

Screw Size	Torque Specifications
M10	36-40 lb-ft
M12	64-69 lb-ft

OPTIONAL CABLE
PART NO. V 3398.
MAY NOT HAVE BEEN
SUPPLIED BY WATEROUS

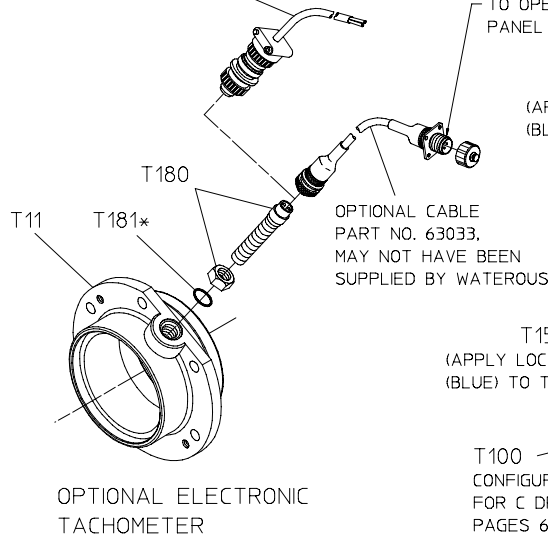

T154
(APPLY LOCTITE #242
(BLUE) TO THREADS)

T100
CONFIGURATION SHOWN
FOR C DROP MODELS. SEE
PAGES 6 & 7 FOR
SPECIFIC SPACER DETAILS

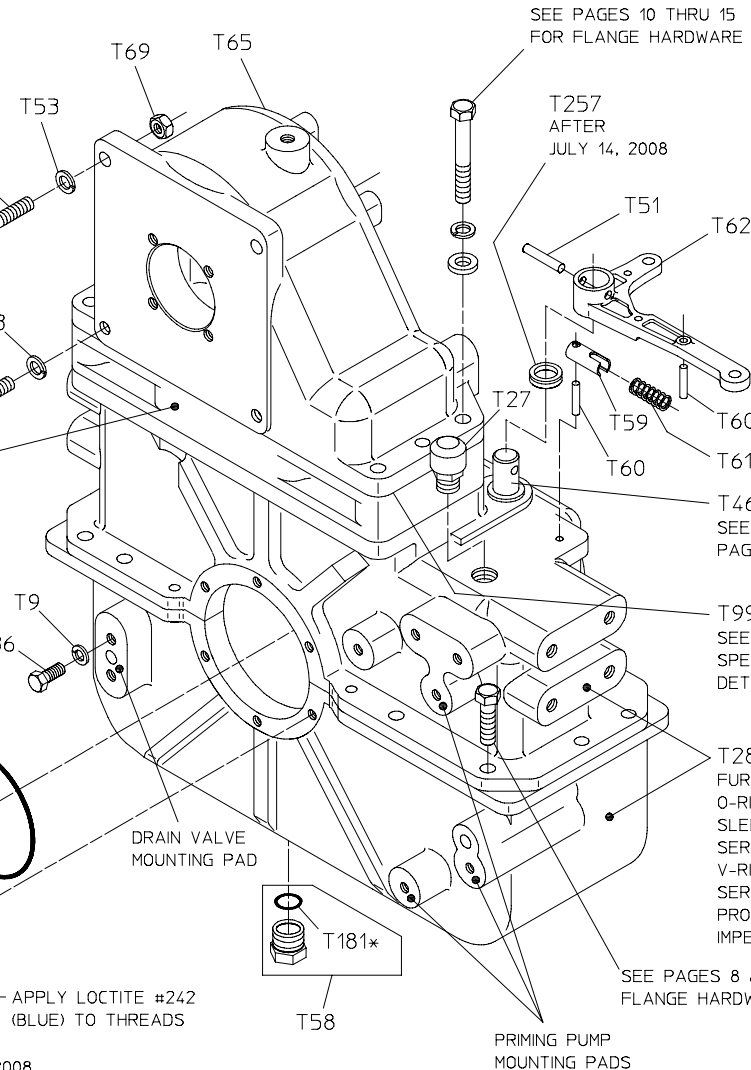
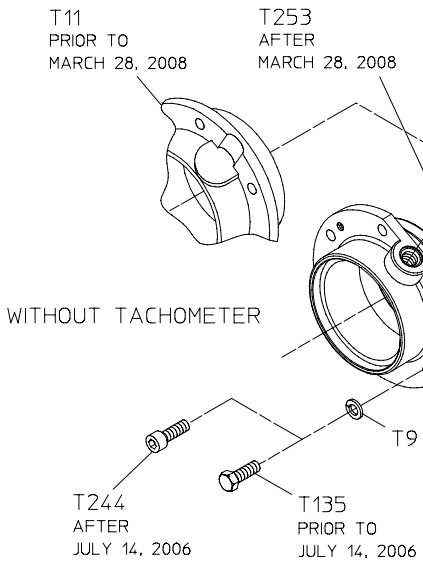

T141
GASKET AND SHIM
REPAIR KIT
*PART OF T141
GASKET AND SHIM REPAIR KIT

CASE ASSEMBLY, VIEWED FROM INPUT SIDE OF CASE
C DROP SHOWN (MODEL C10C)

Case Assembly, Viewed From Output Side of Case

REF. NO.	DESCRIPTION
T9	Lock Washer, M10
T28	Chain Case Subassembly
T41	Aluminum Shim
T42	Bearing Housing
T53	Lock Washer, M12
T55	Shift Cover
T56	Gasket Cover
T58	Magnetic Plug, 3/4-16 (Includes O-ring T181)
T65	Case Cap
T67	Hose
T69	Hex Nut, M12
T72	Threaded Stud, M12 x 35 mm

REF. NO.	DESCRIPTION
T86	Adjusting Screw
T87	Adjusting Screw Retainer
T99	Shim
T100	Spacer
T134	Sight Plug
T135	Hex Hd Screw, M10 x 25 mm
T141	Gasket and Shim Repair Kit
T181	O-ring, 5/8 x 3/4 in.
T182	O-ring, 4-3/4 x 5 in.
T244	Socket Hd Screw, M10 x 25 mm
T249	Hex Hd Screw, M12 x 25 mm
T250	Serial Plate
T251	Round Hd Drive Screw, No. 6 x 1/4 in.

Hardware Torque Specifications:

Screw Size	Torque Specifications
M10	36-40 lb-ft
M12	64-69 lb-ft

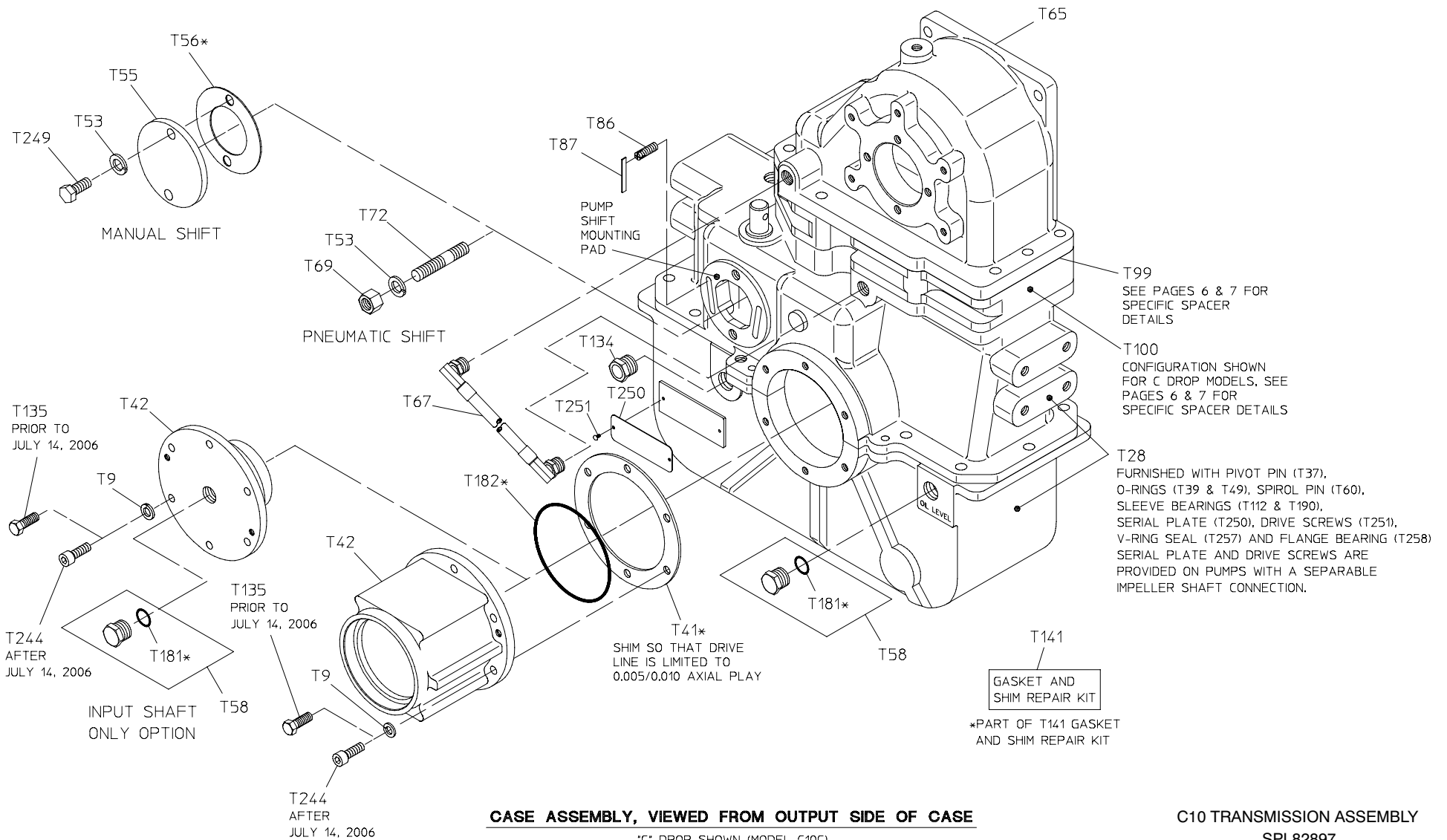

Case Assembly, Spacers and Shims

REF. NO.	DESCRIPTION
T28	Chain Case Subassembly
T65	Case Cap

REF. NO.	DESCRIPTION
T99	Shim
T100	Spacer

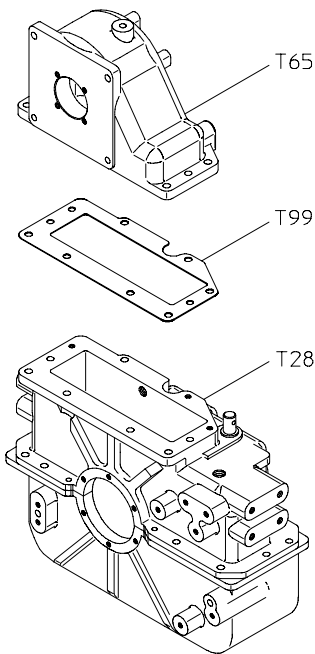

MODEL C10B

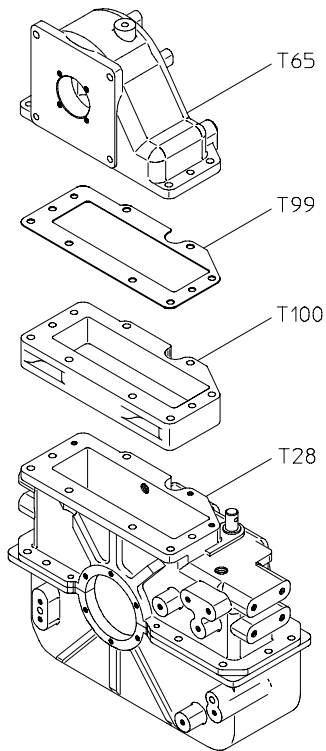

MODEL C10C

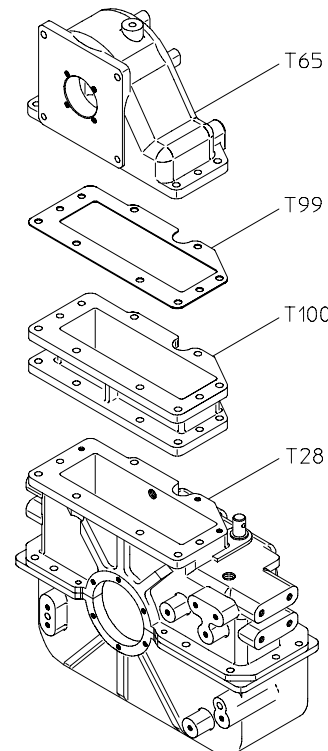

MODEL C10D

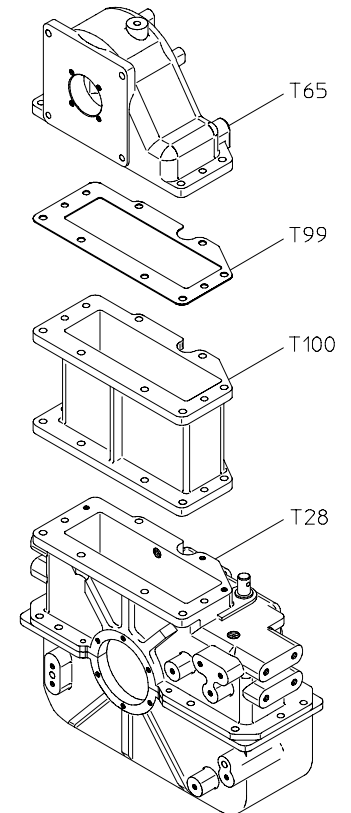

MODEL C10E & C10F

RATIOS	QTY OF T99 SHIMS														
	MODEL C10B			MODEL C10C			MODEL C10D			MODEL C10E			MODEL C10F		
	.010 BROWN	.025 WHITE	.031 ORANGE	.010 BROWN	.025 WHITE	.031 ORANGE	.010 BROWN	.025 WHITE	.031 ORANGE	.010 BROWN	.025 WHITE	.031 ORANGE	.010 BROWN	.025 WHITE	.031 ORANGE
1.27	2	1	0	2	7	2	1	0	2	0	1	1	0	0	1
1.41	0	0	0	1	2	0	0	3	0	0	1	1	0	0	1
1.48	4	2	1	3	2	0	2	0	1	0	0	1	1	0	0
1.58	0	0	0	2	0	0	1	1	0	0	1	0	0	0	0
1.69	1	3	0	0	0	0	0	1	0	0	1	3	0	4	0
1.79	0	0	2	0	0	0	1	0	0	3	2	1	2	2	1
1.88	2	0	0	0	0	0	0	1	0	1	1	1	0	1	1
1.97	2	2	1	0	0	1	0	1	1	0	2	0	2	1	0
2.03	0	0	0	1	1	0	0	0	2	2	2	0	4	1	0
2.27	1	1	0	0	3	0	0	0	0	0	0	0	0	0	0
2.46	2	1	0	0	0	3	0	1	0	2	1	3	2	1	3
2.73	0	0	3	2	2	0	3	2	1	0	1	1	0	1	1

CASE ASSEMBLY, SPACERS AND SHIMS

**C10 TRANSMISSION ASSEMBLY
SPL82897**

**WATEROUS COMPANY
SOUTH ST. PAUL, MN 55075**

Case Hardware, Lower Section of Case

REF. NO.	DESCRIPTION
T52	Hex Hd Screw, M12 x 30 mm
T53	Lock Washer, M12
T69	Hex Nut, M12

REF. NO.	DESCRIPTION
T93	Hex Hd Screw, M12 x 45 mm
T131	Dowel Pin, 3/8 x 1 in.

Hardware Torque Specifications:

Screw Size	Torque Specifications
M10	36-40 lb-ft
M12	64-69 lb-ft

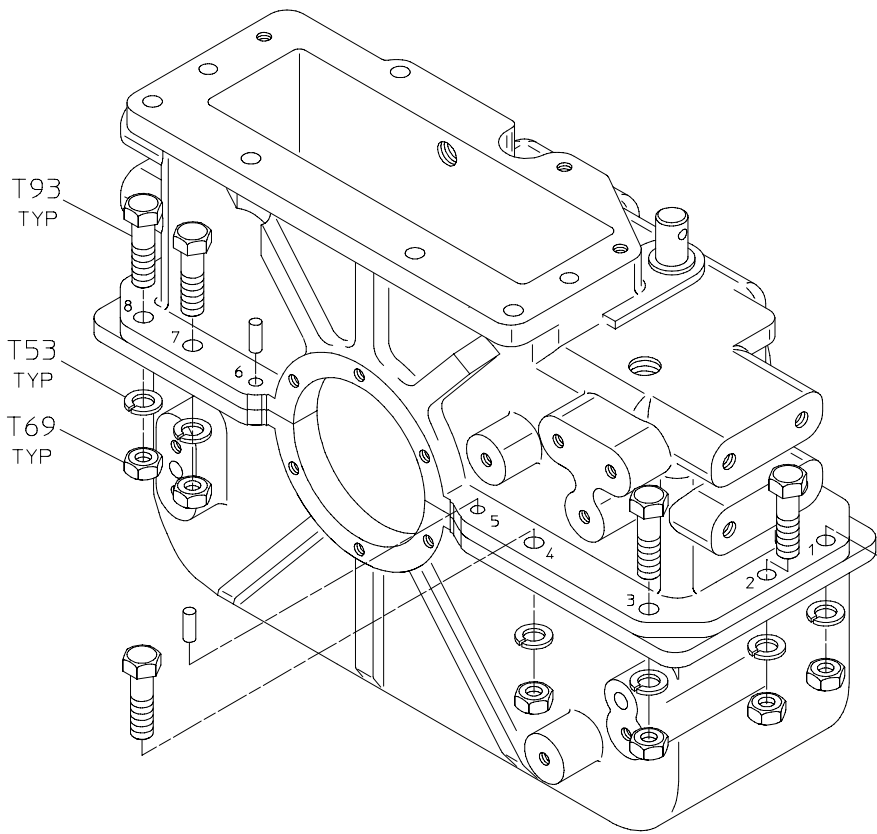

VIEWED FROM INPUT SIDE OF CASE

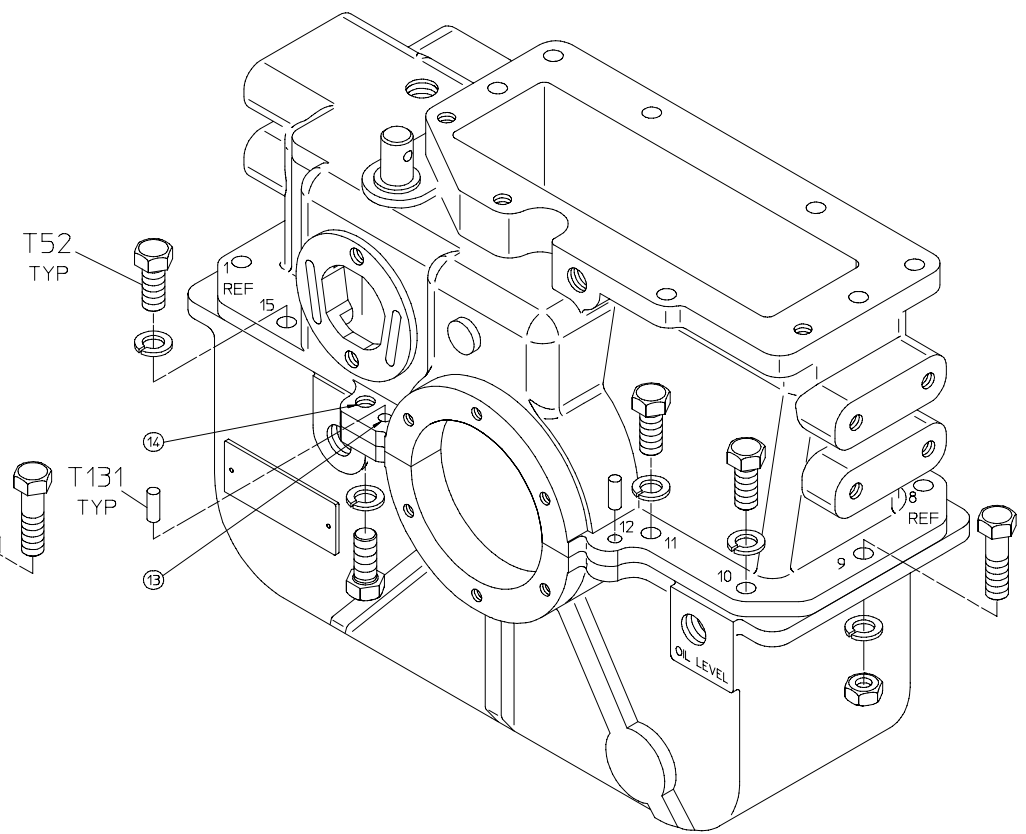

VIEWED FROM OUTPUT SIDE OF CASE

LOWER SECTION OF CASE

REF NO.	HARDWARE DESCRIPTION	HOLE NUMBER															QTY
		1	2	3	4	5	6	7	8	9	10	11	12	13	14	15	
T52	HEX HD SCREW, M12 X 30mm										1	1			1	1	4
T53	LOCK WASHER, M12	1	1	1	1			1	1	1	1	1			1	1	11
T69	HEX NUT, M12	1	1	1	1			1	1	1							7
T93	HEX HD SCREW, M12 X 45mm	1	1	1	1			1	1	1							7
T131	DOWEL PIN, 3/8 X 1"					1	1						1	1			4

CASE HARDWARE, LOWER SECTION OF CASE

Case Hardware, Between Cap and Case, Model C10B

REF. NO.	DESCRIPTION
T53	Lock Washer, M12
T69	Hex Nut, M12
T71	Hex Hd Screw, M12 x 60 mm

REF. NO.	DESCRIPTION
T103	Dowel Pin, 1/2 x 1-1/2 in.
T240	Hex Hd Screw, M12 x 40 mm

Hardware Torque Specifications:

Screw Size	Torque Specifications
M10	36-40 lb-ft
M12	64-69 lb-ft

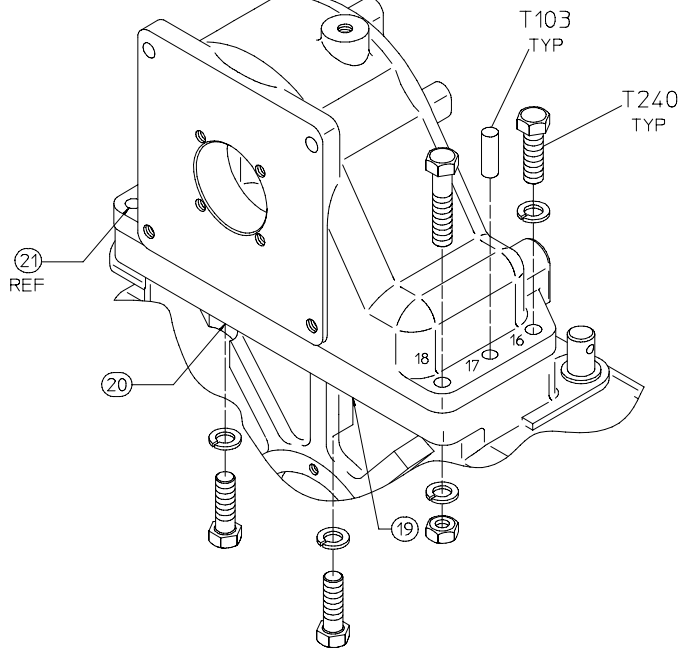

VIEWED FROM INPUT SIDE OF CASE

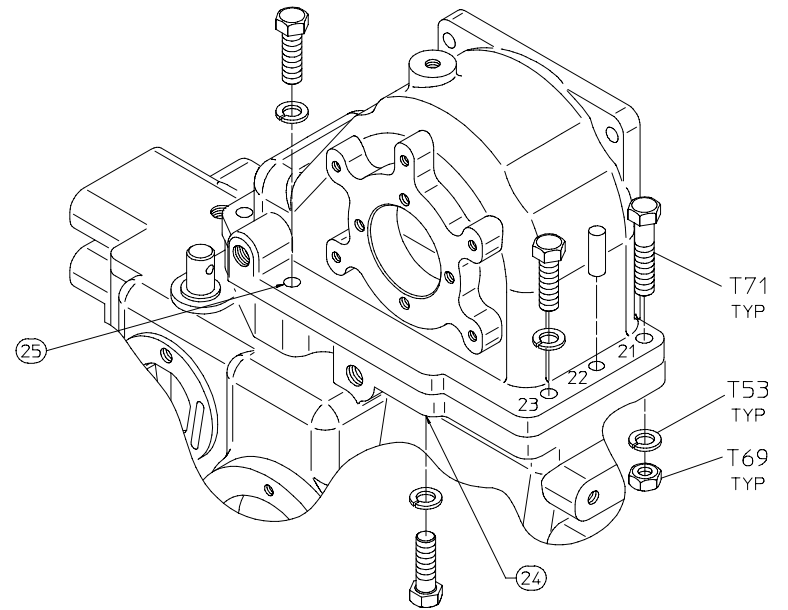

VIEWED FROM OUTPUT SIDE OF CASE

FLANGE HARDWARE BETWEEN CAP (T65) AND CASE (T28)

REF NO.	HARDWARE DESCRIPTION	HOLE NUMBER										QTY
		16	17	18	19	20	21	22	23	24	25	
T53	LOCK WASHER, M12	1		1	1	1	1		1	1	1	8
T69	HEX NUT, M12			1			1					2
T71	HEX HD SCREW, M12 X 60mm			1			1					2
T103	DOWEL PIN, 1/2 X 1 1/2		1					1				2
T240	HEX HD SCREW, M12 X 40mm	1			1	1			1	1	1	6

NOTE:
HOLES 19, 20 AND 24 ARE BLIND HOLES THAT ARE TAPPED INTO THE CAP AND ARE NOT SHOWN.

CASE HARDWARE, BETWEEN CAP AND CASE, MODEL C10B

C10 TRANSMISSION ASSEMBLY
SPL82897
WATEROUS COMPANY
SOUTH ST. PAUL, MN 55075

Case Hardware, Between Cap and Case, Model C10C

REF. NO.	DESCRIPTION
T53	Lock Washer, M12
T68	Hex Hd Screw, M12 x 100 mm
T69	Hex Nut, M12
T70	Hex Hd Screw, M12 x 90 mm

REF. NO.	DESCRIPTION
T73	Flat Extra Thick Washer, 1/2 in.
T103	Dowel Pin, 1/2 x 1-1/2 in.

Hardware Torque Specifications:

Screw Size	Torque Specifications
M10	36-40 lb-ft
M12	64-69 lb-ft

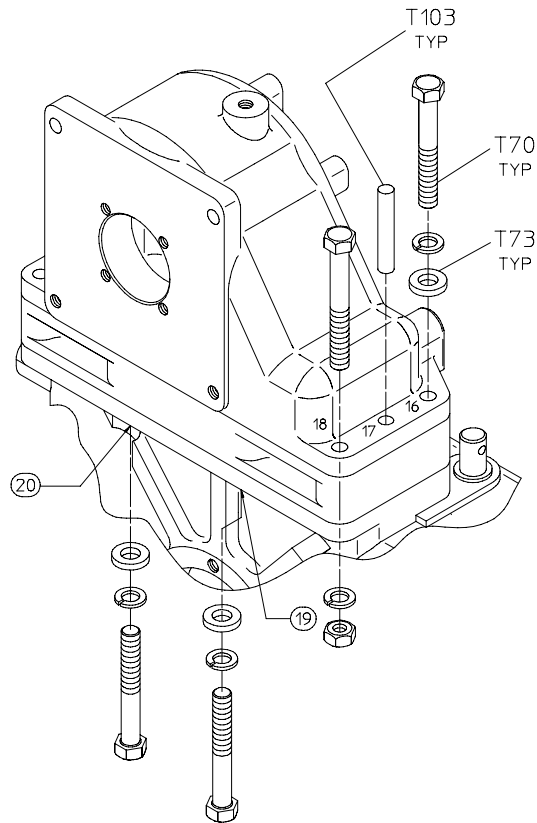

VIEWED FROM INPUT SIDE OF CASE

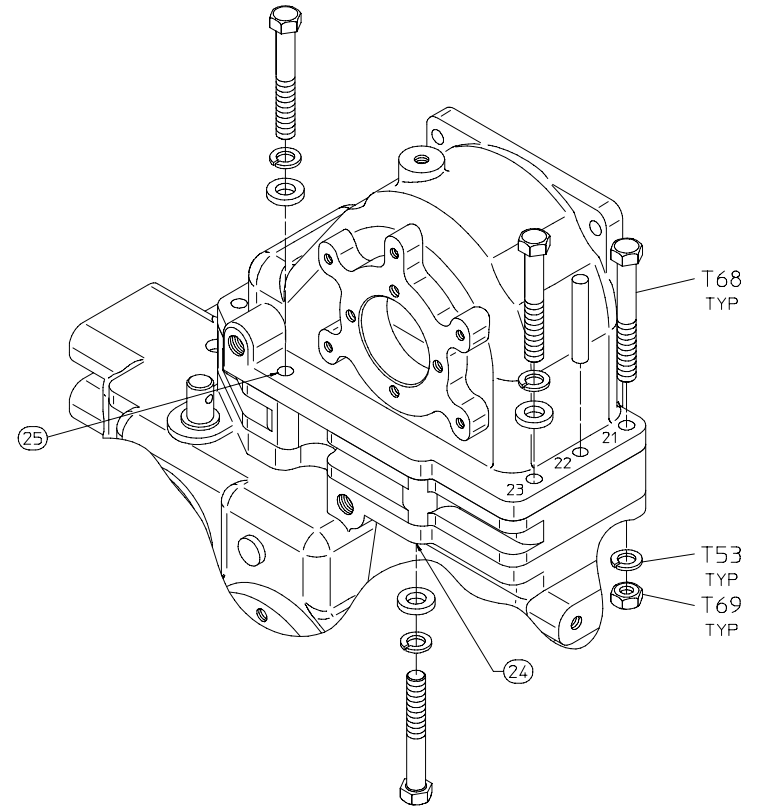

VIEWED FROM OUTPUT SIDE OF CASE

FLANGE HARDWARE BETWEEN CAP (T65) AND CASE (T28)

REF NO.	HARDWARE DESCRIPTION	HOLE NUMBER										QTY
		16	17	18	19	20	21	22	23	24	25	
T53	LOCK WASHER, M12	1		1	1	1	1		1	1	1	8
T68	HEX HD SCREW, M12 X 100mm			1		1						2
T69	HEX NUT, M12			1		1						2
T70	HEX HD SCREW, M12 X 90mm	1		1	1				1	1	1	6
T73	WASHER-EXTRA THICK, 1/2	1		1	1				1	1	1	6
T103	DOWEL PIN, 1/2 X 3		1					1				2

CASE HARDWARE, BETWEEN CAP AND CASE, MODEL C10C

NOTE:
HOLES 19, 20 AND 24 ARE BLIND HOLES THAT ARE TAPPED INTO THE CAP AND ARE NOT SHOWN.

C10 TRANSMISSION ASSEMBLY
SPL82897
WATEROUS COMPANY
SOUTH ST. PAUL, MN 55075
PAGE 13 OF 29

Case Hardware, Between Cap and Case, Models, C10D, C10E, C10F

REF. NO.	DESCRIPTION
T52	Hex Hd Screw, M12 x 30 mm
T53	Lock Washer, M12
T69	Hex Nut, M12

REF. NO.	DESCRIPTION
T103	Dowel Pin, 1/2 x 1-1/2 in.
T106	Hex Hd Screw, M12 x 50 mm

Hardware Torque Specifications:

Screw Size	Torque Specifications
M10	36-40 lb-ft
M12	64-69 lb-ft

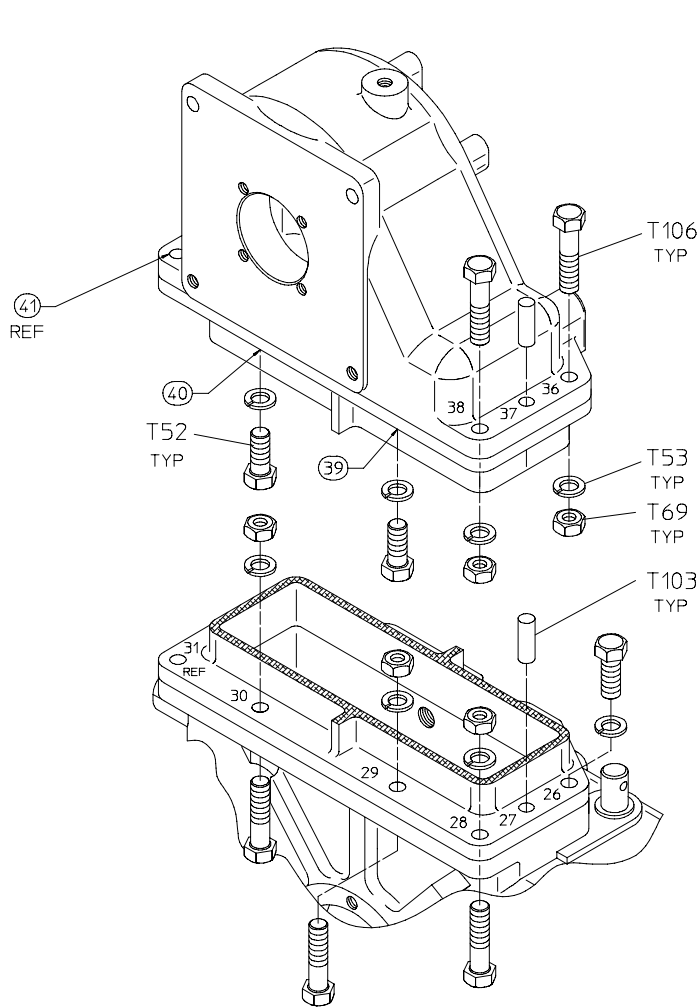

VIEWED FROM INPUT SIDE OF CASE

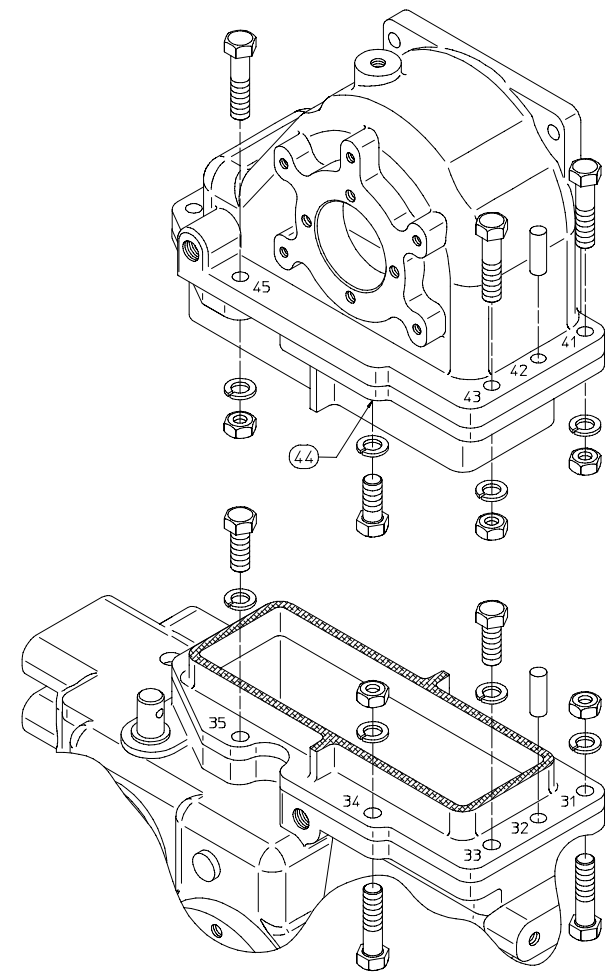

VIEWED FROM OUTPUT SIDE OF CASE

FLANGE HARDWARE BETWEEN CAP (T65) AND CASE (T28)

REF NO.	HARDWARE DESCRIPTION	HOLE NUMBER																				QTY
		26	27	28	29	30	31	32	33	34	35	36	37	38	39	40	41	42	43	44	45	
T52	HEX HD SCREW, M12 X 30mm	1							1		1				1	1			1		6	
T53	LOCK WASHER, M12	1		1	1	1	1		1	1	1	1		1	1	1		1	1	1	16	
T69	HEX NUT, M12			1	1	1	1			1		1		1		1			1		10	
T103	DOWEL PIN, 1/2 X 1-1/2			1					1					1					1		4	
T106	HEX HD SCREW, M12 X 50mm			1	1	1	1			1		1		1			1	1	1	1	10	

CASE HARDWARE, BETWEEN CAP AND CASE, MODELS C10D, C10E & C10F

NOTE:
HOLES 39, 40 AND 44 ARE BLIND HOLES THAT ARE TAPPED INTO THE CAP AND ARE NOT SHOWN.

C10 TRANSMISSION ASSEMBLY
SPL82897
WATROUS COMPANY
SOUTH ST. PAUL, MN 55075
PAGE 15 OF 29

Oil Cooler Option

REF. NO.	DESCRIPTION
T66	Straight Adapter, 1/2 in.
T132	Oil Strainer
T247	Hose

REF. NO.	DESCRIPTION
T254	Pipe Nipple, 1/2 NPT x 1-1/8 in.
T255	Pipe Tee, 1/2 NPT
T256	Pipe Plug, 1/2 NPT

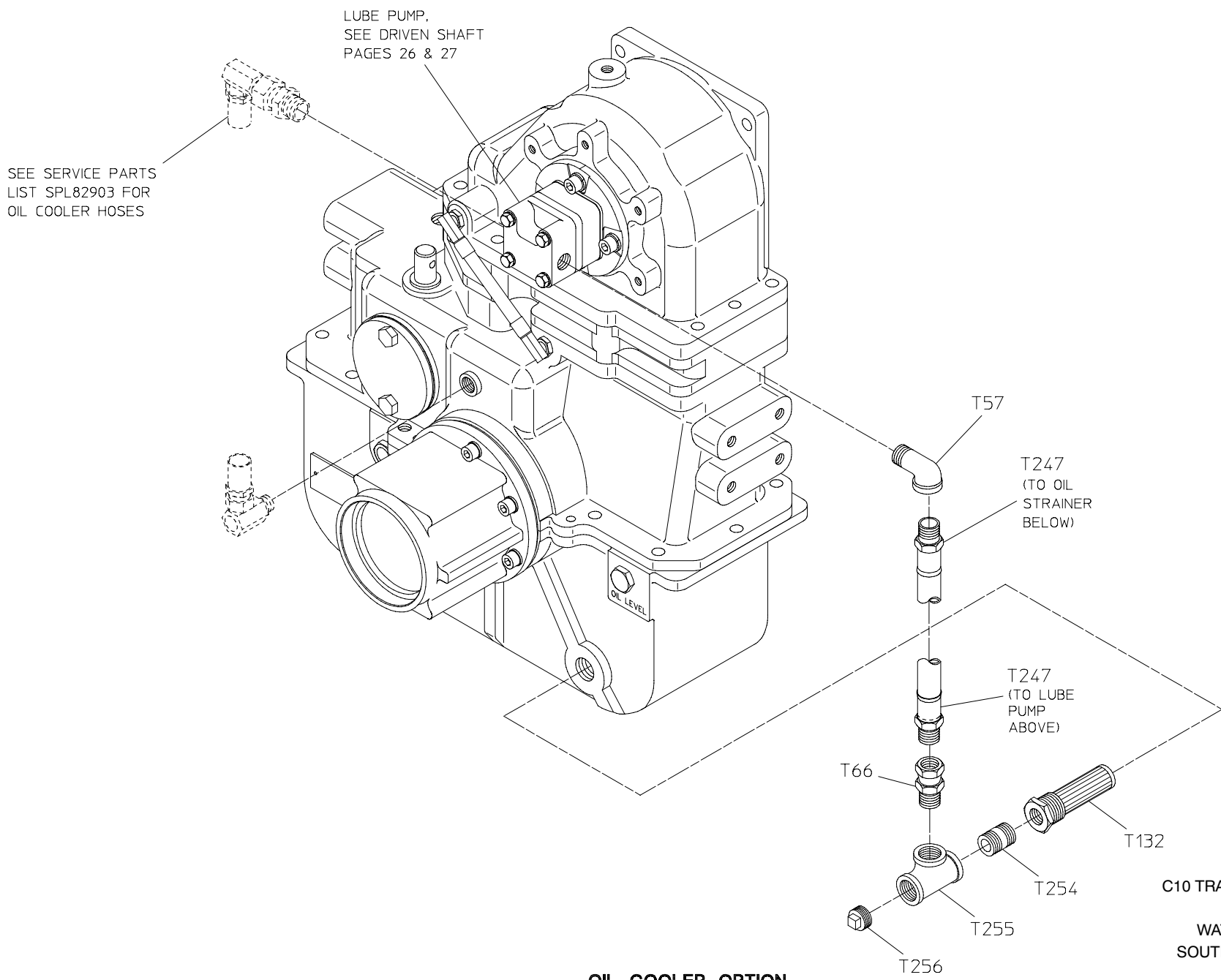

OIL COOLER OPTION

Driveline, Input and Output Shaft

REF. NO.	DESCRIPTION
T2	Coupling Shaft Spacer
T3	Ball Bearing
T4	Shift Collar
T5	Drive Sprocket
T6	Needle Bearing
T7	Thrust Washer
T10	Tachometer Pulse Generator
T13	Drive Shaft
T15	Ball Bearing
T18	Chain
T37	Pivot Pin, 5/8 x 2-3/4 in.
T38	Locking Arm
T39	O-ring, 1/4 x 3/8 in.
T40	Shifter Shoe
T43	Self-Locking Nut, 1-1/4 in.
T44	Coupling Shaft
T46	Shift Shaft
T47	Sector Gear
T48	Sector Spacer

REF. NO.	DESCRIPTION
T49	O-ring, 7/8 x 1 in.
T50	Sleeve Bearing
T62	Shift Arm
T75	Shifter Shoe
T80	Shift Fork
T83	Connecting Pin Set
T94	Plain Washer, 1-1/4 in.
T104	Drive Shaft Spacer
T108	Heavy Spilrol Pin, 1/16 x 1/4 in.
T112	Sleeve
T141	Gasket and Shim Repair Kit
T173	Shift Lever
T187	Oil Seal, 3-1/2 x 4-3/8 in.
T190	Sleeve Bearing
T230	Drive Shaft Spacer
T237	Shoulder Screw, 3/8 x 1-3/4 in.
T238	Lock Nut, 5/16-18
T252	Tachometer Ring
T257	V-Ring Seal
T258	Flanged Bearing

Driveline, Input Shaft Only

REF. NO.	DESCRIPTION
T3	Ball Bearing
T4	Shift Collar
T5	Drive Sprocket
T6	Needle Bearing
T7	Thrust Washer
T10	Tachometer Pulse Generator
T13	Drive Shaft
T15	Ball Bearing
T18	Chain
T37	Pivot Pin, 5/8 x 2-3/4 in.
T38	Locking Arm
T39	O-ring, 1/4 x 3/8 in.
T40	Shifter Shoe
T43	Self-Locking Nut, 1-1/4 in.
T46	Shift Shaft
T47	Sector Gear
T48	Sector Spacer
T49	O-ring, 7/8 x 1 in.
T50	Sleeve Bearing

REF. NO.	DESCRIPTION
T62	Shift Arm
T75	Shifter Shoe
T80	Shift Fork
T83	Connecting Pin Set
T94	Plain Washer, 1-1/4 in.
T104	Drive Shaft Spacer
T108	Heavy Spilrol Pin, 1/16 x 1/4 in.
T112	Sleeve
T141	Gasket and Shim Repair Kit
T173	Shift Lever
T187	Oil Seal, 3-1/2 x 4-3/8 in.
T190	Sleeve Bearing
T230	Drive Shaft Spacer
T237	Shoulder Screw, 3/8 x 1-3/4 in.
T238	Lock Nut, 5/16-18
T252	Tachometer Ring
T257	V-Ring Seal
T258	Flanged Bearing

OPTIONAL END YOKES, CROSS & BEARING KITS
AND COMPANION FLANGE

SERIES	YOKE PART NO.	CROSS & BRG KIT NO.
1710	V 2837	V 2839
1810	V 2838	V 2840
SPL140	V 3388	V 3389
COMPANION FLANGE NO.		
1650/1710	V 3619	

MAY NOT HAVE BEEN SUPPLIED BY WATEROUS

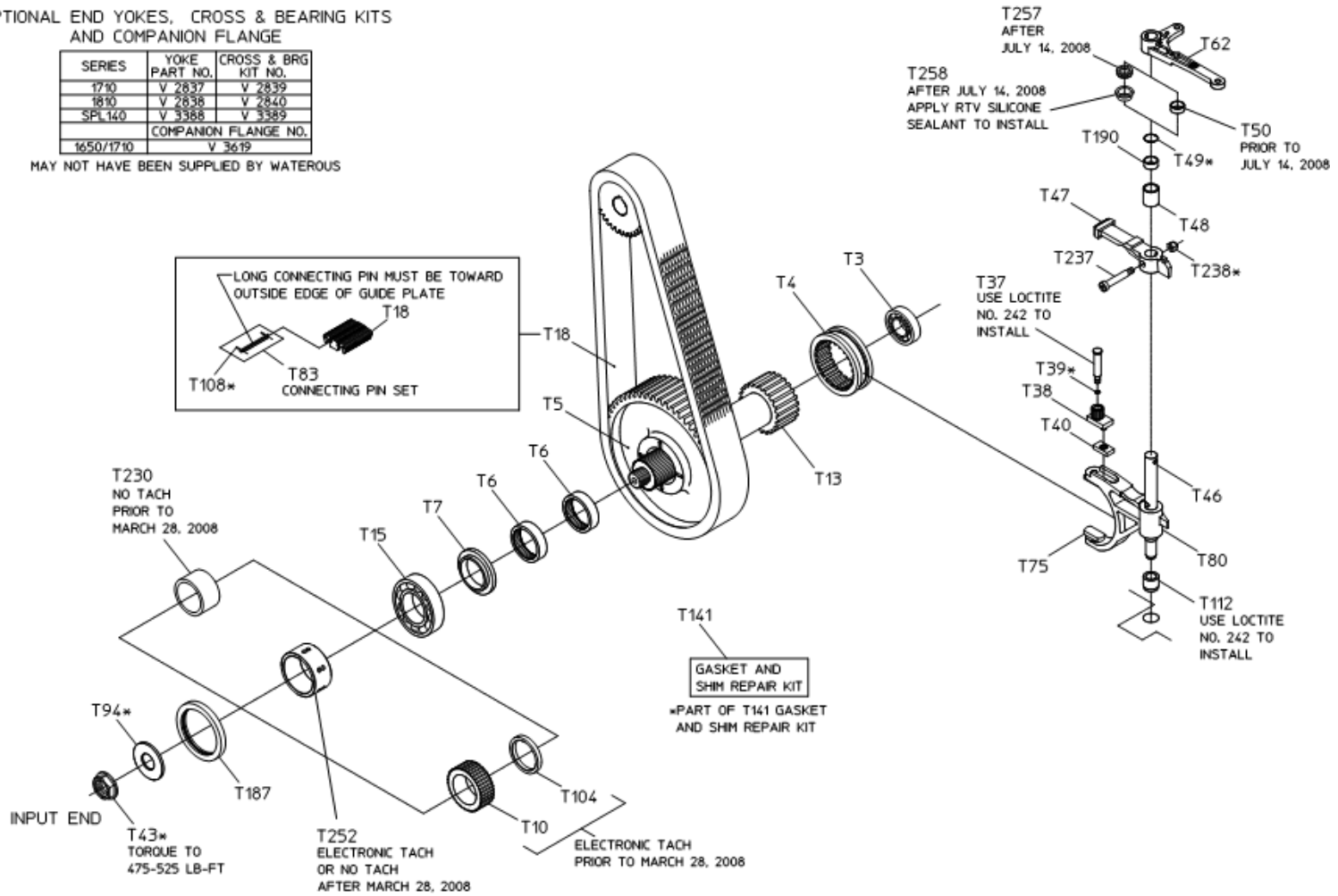

DRIVELINE, INPUT SHAFT ONLY

Driven Shaft Components

REF. NO.	DESCRIPTION
T9	Lock Washer, M10
T19	Oil Seal
T23	Oil Seal Housing
T24	Gasket
T25	Ball Bearing
T26	Driven Sprocket
T29	Bearing Spacer
T31	Oil Seal Housing
T32	Bearing Nut Washer
T33	Lock Bearing Nut
T65	Case Cap
T95	Bearing Spacer

REF. NO.	DESCRIPTION
T120	Driven Shaft
T135	Hex Hd Screw, M10 x 25 mm
T138	Boot
T141	Gasket and Shim Repair Kit
T183	Ball Bearing
T232	Square Key, 5-16 x 1-3/4 in.
T241	Wave Spring
T242	Oil Seal
T243	Retaining Ring
T244	Socket Hd Screw, M10 x 25 mm
T246	Square Key, 5/16 x 2-5/16 in.
T248	O-ring, 3-1/4 x 3-7/16 in.

Hardware Torque Specifications:

Screw Size	Torque Specifications
M10	36-40 lb-ft
M12	64-69 lb-ft

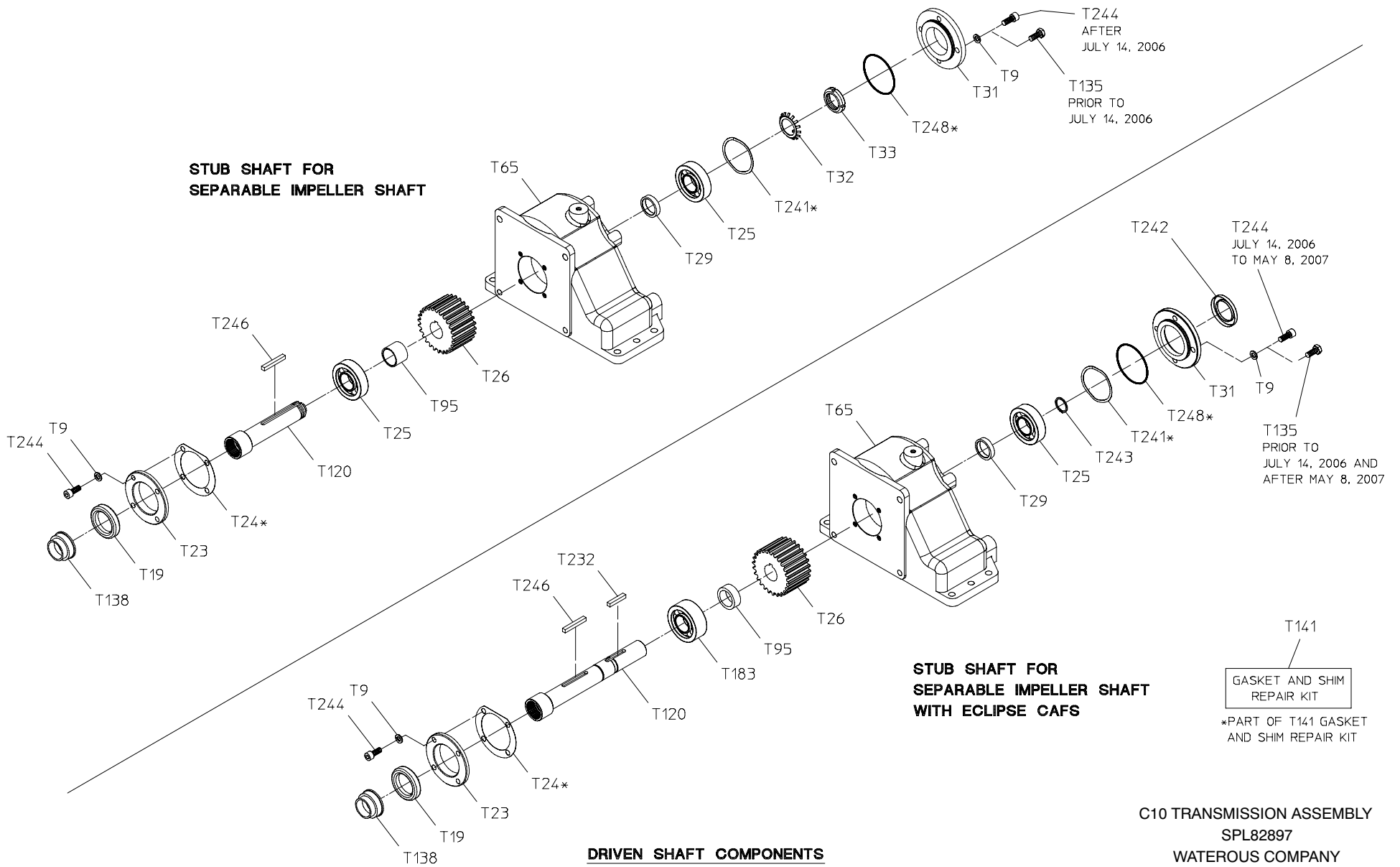

Driven Shaft Components

REF. NO.	DESCRIPTION
T9	Lock Washer, M10
T19	Oil Seal
T23	Oil Seal Housing
T24	Gasket
T25	Ball Bearing
T26	Driven Sprocket
T29	Bearing Spacer
T32	Bearing Nut Washer
T33	Bearing Lock Nut
T65	Case Cap
T95	Bearing Spacer

REF. NO.	DESCRIPTION
T120	Driven Shaft
T135	Hex Hd Screw, M10 x 25 mm
T138	Boot
T141	Gasket and Shim Repair Kit
T169	Hydraulic Adapter or Oil Seal Housing
T170	Oil Seal Sleeve
T241	Wave Spring
T242	Oil Seal
T243	Retaining Ring
T244	Socket Hd Screw, M10 x 25 mm
T246	Square Key, 5/16 x 2-5/16 in.
T248	O-ring, 3-1/4 x 3-7/16 in.

Hardware Torque Specifications:

Screw Size	Torque Specifications
M10	36-40 lb-ft
M12	64-69 lb-ft

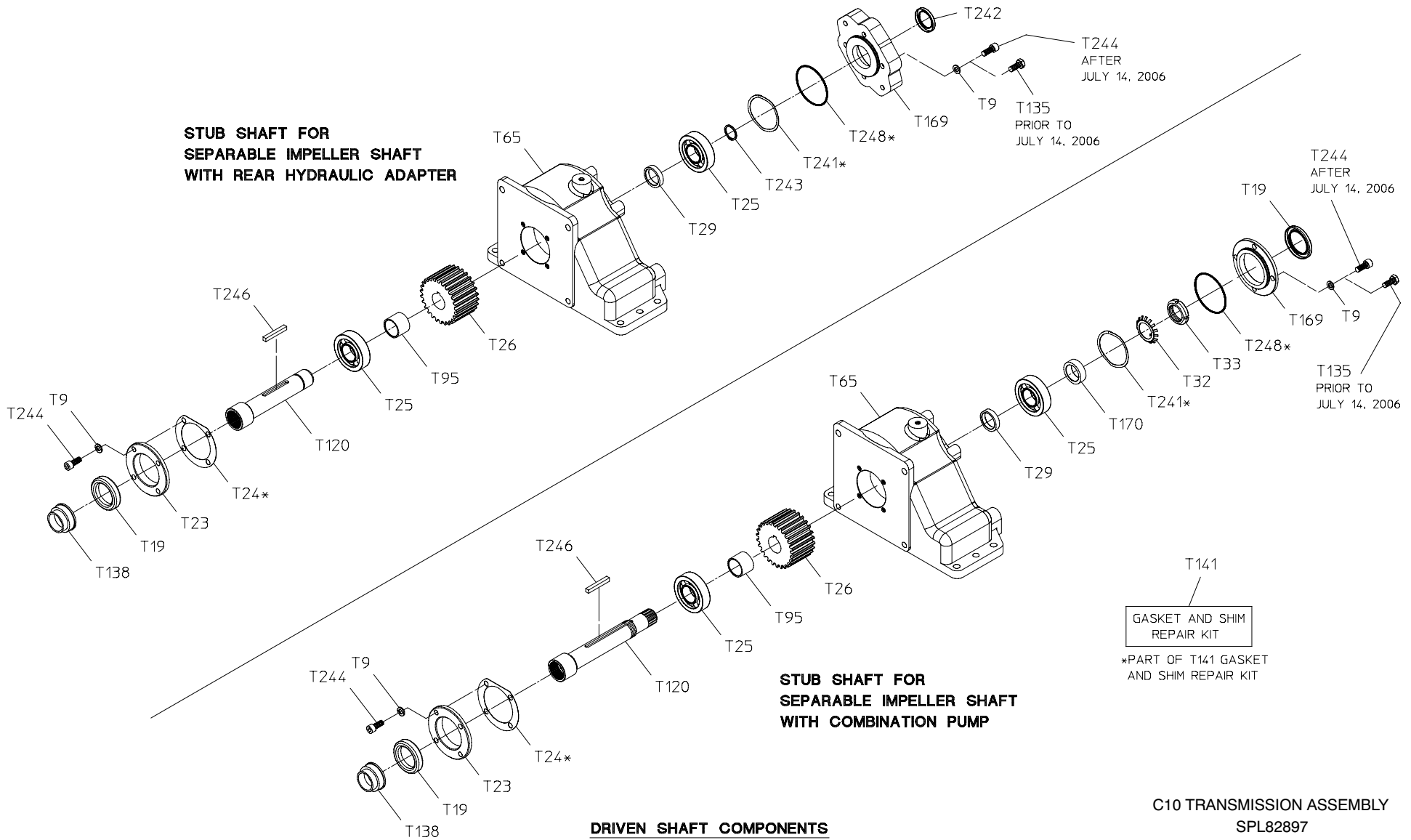

Driven Shaft Components

REF. NO.	DESCRIPTION
T9	Lock Washer, M10
T19	Oil Seal
T22	Lock Washer, 5/16 in.
T23	Oil Seal Housing
T24	Gasket
T25	Ball Bearing
T26	Driven Sprocket
T29	Bearing Spacer
T31	Oil Seal Housing
T32	Bearing Nut Washer
T33	Bearing Lock Nut
T34	Lube Pump

REF. NO.	DESCRIPTION
T65	Case Cap
T95	Bearing Spacer
T96	Pump Gasket
T97	Hex Hd Screw, 5/16-18 x 3-1/2 in.
T120	Driven Shaft
T135	Hex Hd Screw, M10 x 25 mm
T138	Boot
T141	Gasket and Shim Repair Kit
T183	Ball Bearing
T241	Wave Spring
T244	Socket Hd Screw, M10 x 25 mm
T246	Square Key, 5/16 x 2-5/16 in.
T248	O-ring, 3-1/4 x 3-7/16 in.

Hardware Torque Specifications:

Screw Size	Torque Specifications
M10	36-40 lb-ft
M12	64-69 lb-ft

Driven Shaft Components

REF. NO.	DESCRIPTION
T9	Lock Washer, M10
T19	Oil Seal
T23	Oil Seal Housing
T24	Gasket
T25	Ball Bearing
T26	Driven Sprocket
T29	Bearing Spacer
T31	Oil Seal Housing
T32	Bearing Nut Washer
T33	Bearing Lock Nut

REF. NO.	DESCRIPTION
T65	Case Cap
T95	Bearing Spacer
T135	Hex Hd Screw, M10 x 25 mm
T141	Gasket and Shim Repair Kit
T183	Ball Bearing
T241	Wave Spring
T242	Oil Seal
T243	Retaining Ring
T244	Socket Hd Screw, M10 x 25 mm
T248	O-ring, 3-1/4 x 3-7/16 in.

Hardware Torque Specifications:

Screw Size	Torque Specifications
M10	36-40 lb-ft
M12	64-69 lb-ft

**ONE-PIECE (PUMP IMPELLER SHAFT)
WITH ECLIPSE ES CAFS**

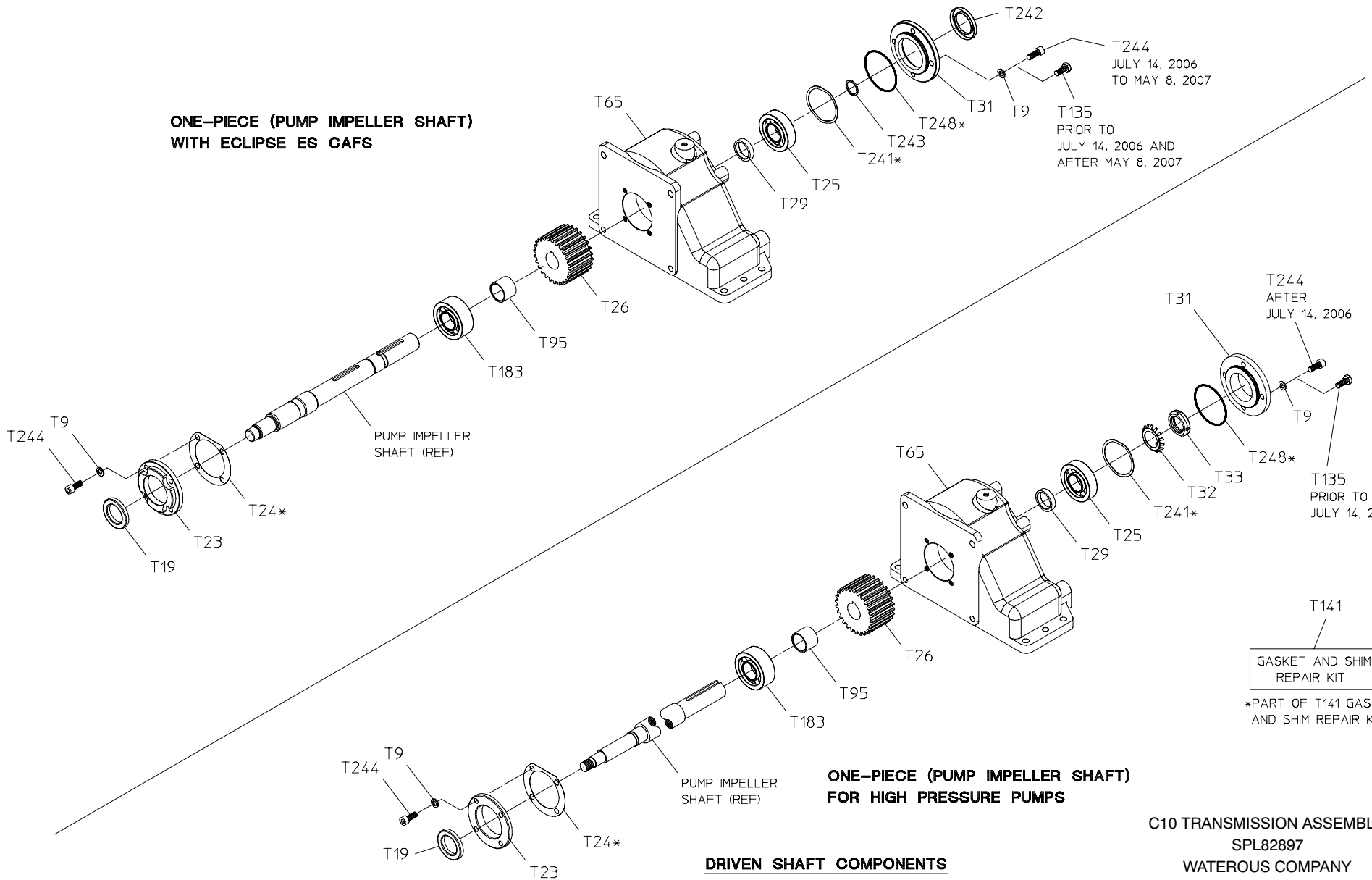

**ONE-PIECE (PUMP IMPELLER SHAFT)
FOR HIGH PRESSURE PUMPS**

DRIVEN SHAFT COMPONENTS

T141
GASKET AND SHIM
REPAIR KIT

*PART OF T141 GASKET
AND SHIM REPAIR KIT

WATEROUS

125 Hardman Avenue South, South St. Paul, Minnesota 55075-2456 USA (651) 450-5000