

C20 Series Transmission Service Parts List

As used with S100 Pump Models

Index:

Components				See Page		
Driven Shaft	Pump Mounting On Transmission	Output Connection Opposite Pump				
	Driven Shaft	Front (Input Shaft Side)	Rear (Output Shaft Side)	None (Blank)	2, 3	
Hydraulic Pump (SAE Class B 2-Bolt Hydraulic Flange)				4, 5		
Eclipse™ ES CAFS				6, 7		
Rear (Output Shaft Side)		Front (Input Shaft Side)	None (Blank)	8, 9		
Driven Shaft	Rear (Output Shaft Side)	Front (Input Shaft Side)	Hydraulic Pump (SAE Class B 2-Bolt Hydraulic Flange)	10, 11		
			Input and Output Shafts		Exploded View	12, 13
			Input Shaft Only		Cross-Section View	14, 15
			Input Shaft Only		Exploded View	16, 17
Input Shaft Only		Cross-Section View	18, 19			
Shift Unit	See Shift Unit Service Parts List			--		
Case	Viewed from Input Side (After January 1, 2011)			20, 21		
	Viewed from Input Side (Prior to January 1, 2011)			22, 23		
	Viewed from Output Side (After January 1, 2011)			24, 25		
	Viewed from Output Side (Prior to January 1, 2011)			26, 27		
	Cap Variations	Spacers, Shims and Sealant Application		Models C20B, C20C, C20D, C20E, C20F	28, 29	
		Hardware		Models C20B	30, 31	
				Models C20C	32, 33	
				Models C20D, C20E, C20F	34, 35	
Optional Accessories	Transmission Mounted Drain Valve		See Drain Valve Service List			
	Model VPO Priming Pump		See Priming Pump Service Parts List			

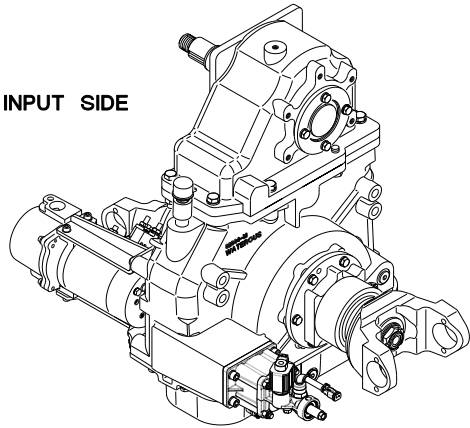

INPUT SIDE

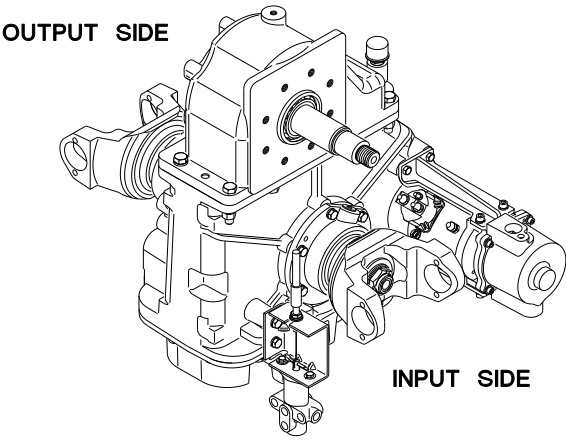

OUTPUT SIDE

Driven Shaft - Pump Mounting: Front (Input Shaft Side)
Connection Opposite Pump: None (Blank)

REF. NO.	DESCRIPTION
T8	Hex Hd Screw, 3/8-16 x 1 in.
T9	Lock Washer, 3/8 in.
T18	Chain
T25	Single Row Ball Bearing
T26	Driven Sprocket
T29	Bearing Spacer, .342 in. Wide
T30	Double Row Ball Bearing
T31	Bearing Cover
T32	Bearing Lock Nut Washer (W07)
T33	Bearing Lock Nut (N07)

REF. NO.	DESCRIPTION
T40	Wave Spring, 80 mm
T49	Hex Hd Screw, 1/2-13 x 1-1/4 in.
T53	Lock Washer, 1/2 in.
T65	Case Cap
T95	Bearing Spacer, 1.214 Wide
T133	O-ring, 3-1/4 x 3-7/16 in.
T141	Gasket and O-ring Repair Kit

Hardware Torque Specifications

Screw Size	Torque Specification
5/16-18 UNC	17 lb-ft
3/8-16 UNC	31 lb-ft
1/2-13 UNC	75 lb-ft
1/2-20 UNF	85 lb-ft
5/8-11 UNC	150 lb-ft

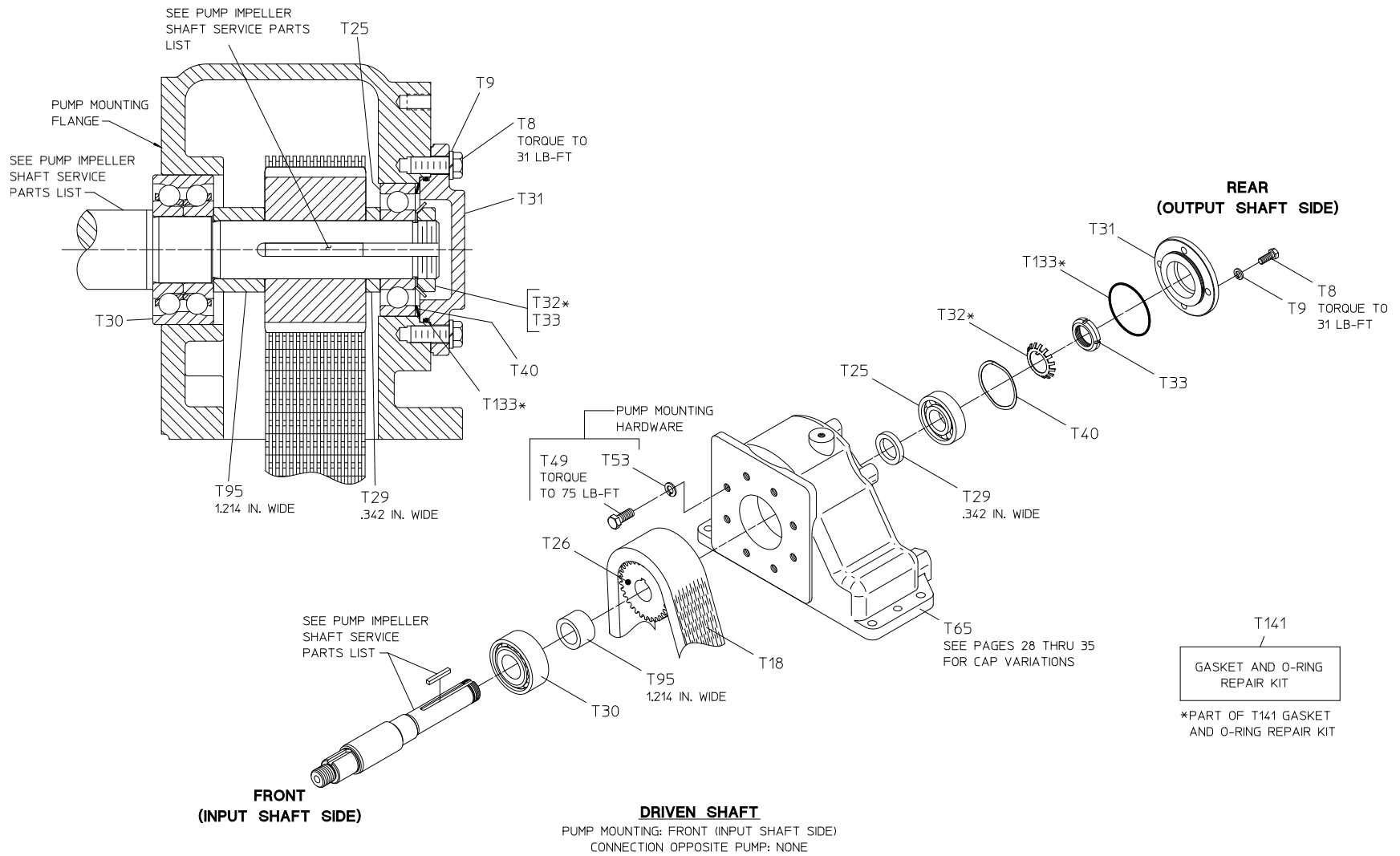

Driven Shaft - Pump Mounting: Front (Input Shaft Side)

Connection Opposite Pump: Hydraulic Pump

REF. NO.	DESCRIPTION
T8	Hex Hd Screw, 3/8-16 x 1 in.
T9	Lock Washer, 3/8 in.
T18	Chain
T25	Single Row Ball Bearing
T26	Driven Sprocket
T29	Bearing Spacer, .342 in. Wide
T30	Double Row Ball Bearing

REF. NO.	DESCRIPTION
T40	Wave Spring, 80 mm
T49	Hex Hd Screw, 1/2-13 x 1-1/4 in.
T53	Lock Washer, 1/2 in.
T65	Case Cap
T95	Bearing Spacer, 1.214 Wide
T122	Hydraulic Adapter, SAE Class B 2-Bolt
T128	Oil Seal, 1-3/8 x 2 x 5/16 in.
T129	Retaining Ring
T133	O-ring, 3-1/4 x 3-7/16 in.
T141	Gasket and O-ring Repair Kit

Hardware Torque Specifications

Screw Size	Torque Specification
5/16-18 UNC	17 lb-ft
3/8-16 UNC	31 lb-ft
1/2-13 UNC	75 lb-ft
1/2-20 UNF	85 lb-ft
5/8-11 UNC	150 lb-ft

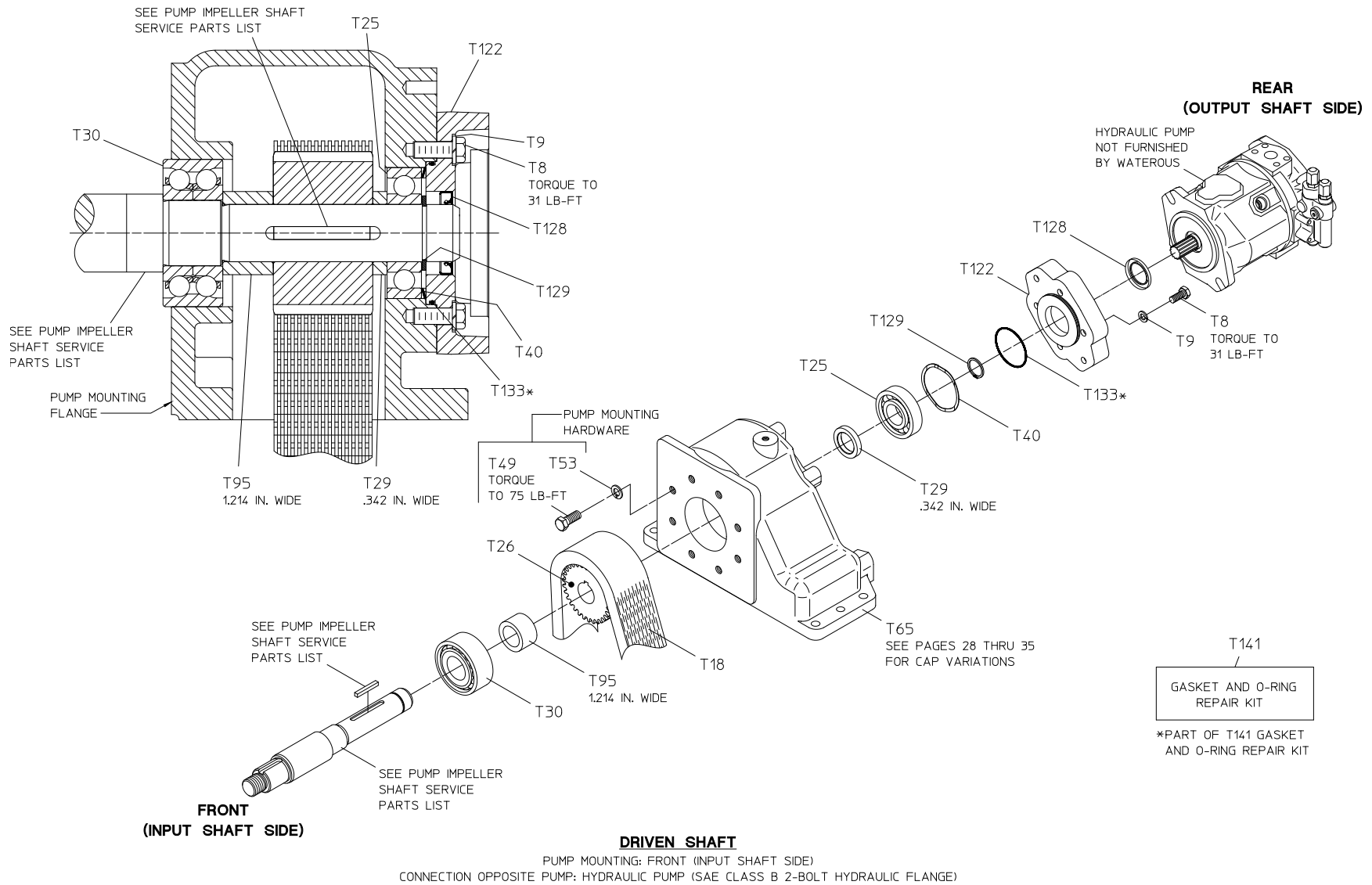

Driven Shaft - Pump Mounting: Front (Input Shaft Side) Configuration Opposite Pump: Eclipse™ ES CAFS

REF. NO.	DESCRIPTION
T8	Hex Hd Screw, 3/8-16 x 1 in.
T9	Lock Washer, 3/8 in.
T18	Chain
T25	Single Row Ball Bearing
T26	Driven Sprocket
T29	Bearing Spacer, .342 in. Wide
T30	Double Row Ball Bearing
T31	Oil Seal Housing

REF. NO.	DESCRIPTION
T40	Wave Spring, 80 mm
T49	Hex Hd Screw, 1/2-13 x 1-1/4 in.
T53	Lock Washer, 1/2 in.
T65	Case Cap
T95	Bearing Spacer, 1.214 Wide
T127	Oil Seal, 1-3/8 x 2-5/8 x 5/16 in.
T129	Retaining Ring
T133	O-ring, 3-1/4 x 3-7/16 in.
T141	Gasket and O-ring Repair Kit

Hardware Torque Specifications

Screw Size	Torque Specification
5/16-18 UNC	17 lb-ft
3/8-16 UNC	31 lb-ft
1/2-13 UNC	75 lb-ft
1/2-20 UNF	85 lb-ft
5/8-11 UNC	150 lb-ft

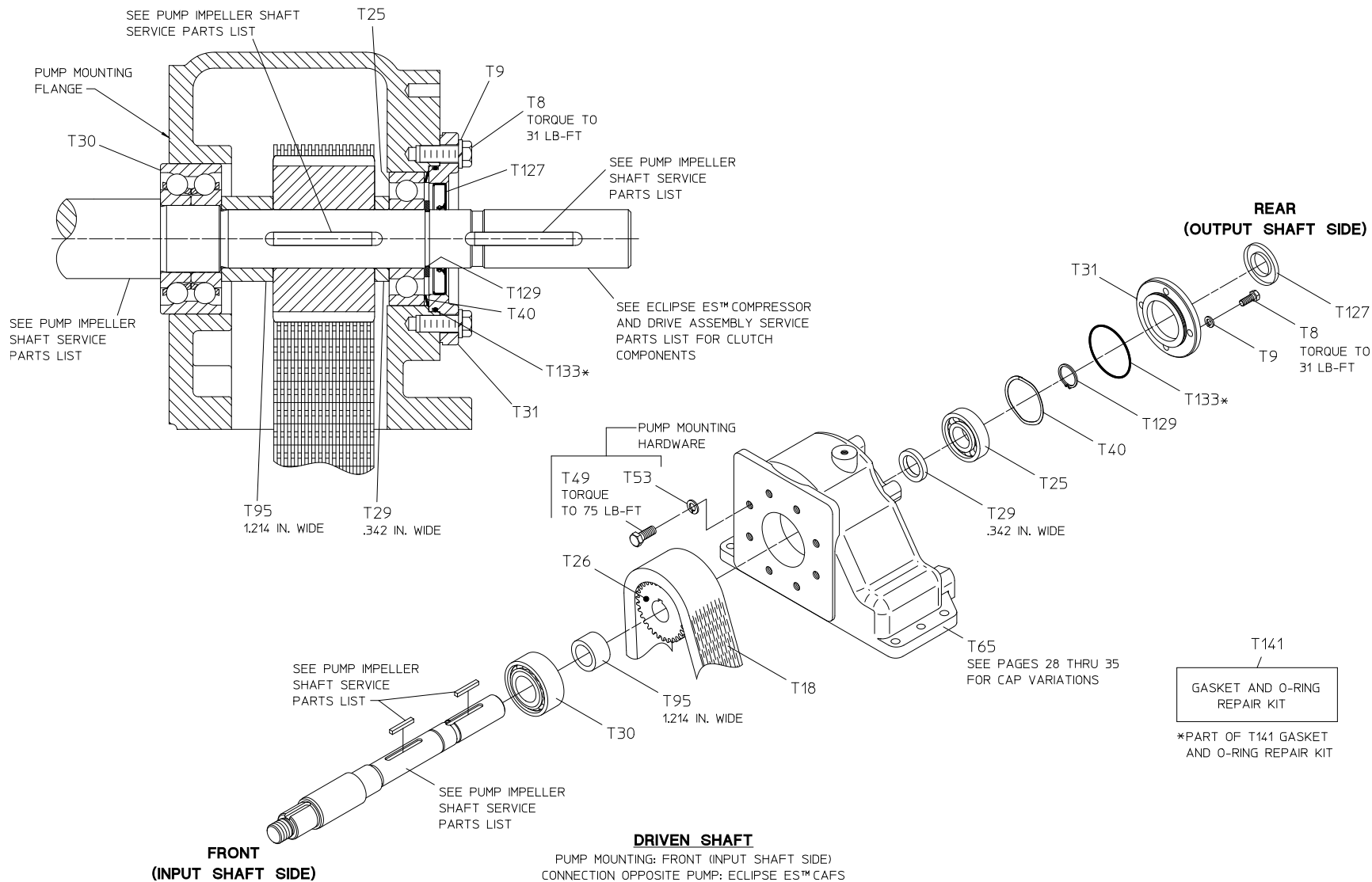

Driven Shaft - Pump Mounting: Rear (Output Shaft Side)

Connection Opposite Pump: None (Blank)

REF. NO.	DESCRIPTION
T8	Hex Hd Screw, 3/8-16 x 1 in.
T9	Lock Washer, 3/8 in.
T18	Chain
T25	Single Row Ball Bearing
T26	Driven Sprocket
T29	Bearing Spacer, 1.565 in. Wide
T30	Double Row Ball Bearing
T31	Bearing Cover
T32	Bearing Lock Nut Washer (W07)
T33	Bearing Lock Nut (N07)

REF. NO.	DESCRIPTION
T40	Wave Spring, 80 mm
T49	Hex Hd Screw, 1/2-13 x 1-1/4 in.
T53	Lock Washer, 1/2 in.
T65	Case Cap
T95	Bearing Spacer, 2.240 Wide
T131	O-ring, 2-3/4 x 3 in.
T141	Gasket and O-ring Repair Kit

Hardware Torque Specifications

Screw Size	Torque Specification
5/16-18 UNC	17 lb-ft
3/8-16 UNC	31 lb-ft
1/2-13 UNC	75 lb-ft
1/2-20 UNF	85 lb-ft
5/8-11 UNC	150 lb-ft

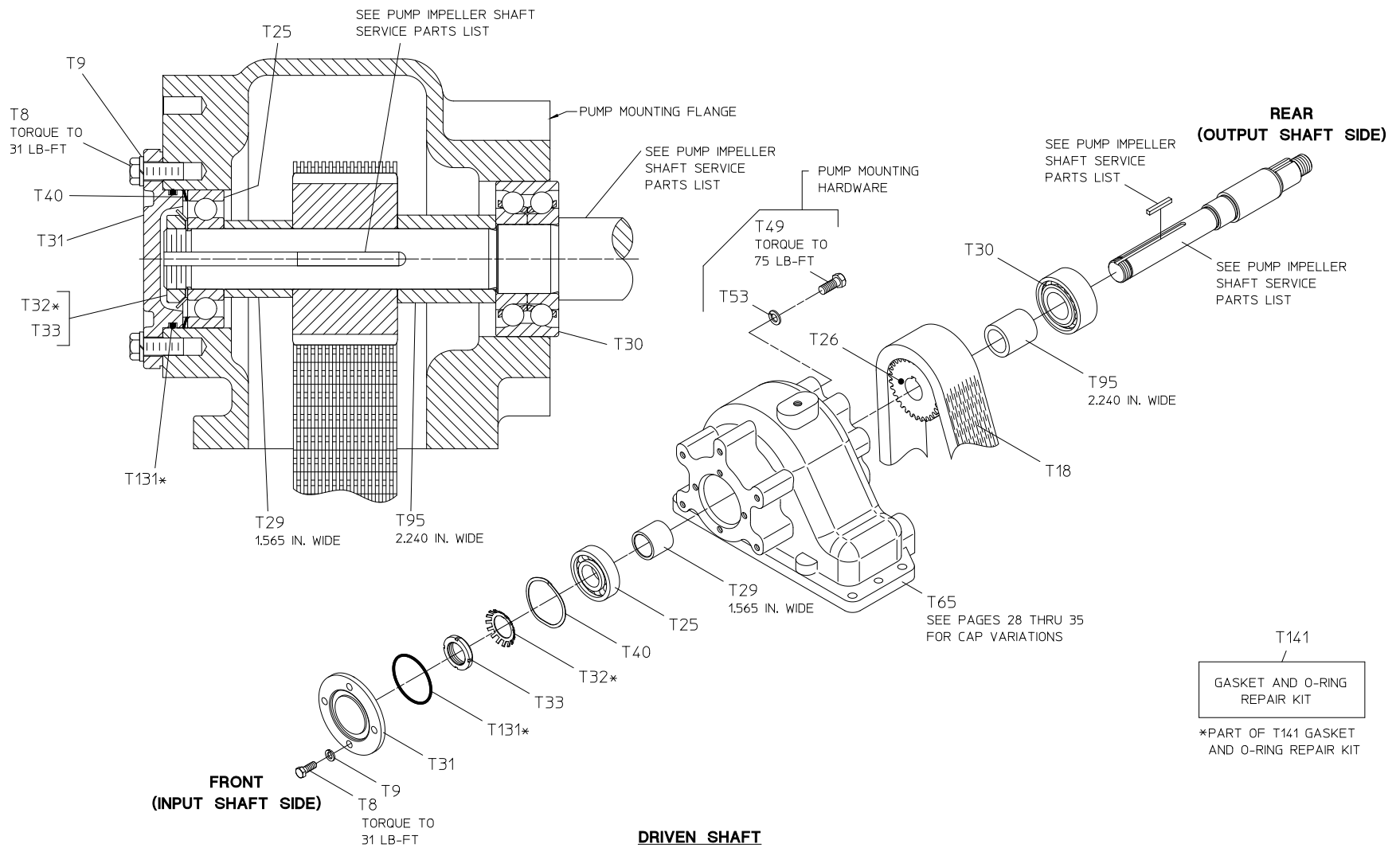

Driven Shaft - Pump Mounting: Rear (Output Shaft Side)

Connection Opposite Pump: Hydraulic Pump

REF. NO.	DESCRIPTION
T8	Hex Hd Screw, 3/8-16 x 1 in.
T9	Lock Washer, 3/8 in.
T18	Chain
T25	Single Row Ball Bearing
T26	Driven Sprocket
T29	Bearing Spacer, 1.565 in. Wide
T30	Double Row Ball Bearing
T40	Wave Spring, 80 mm

REF. NO.	DESCRIPTION
T49	Hex Hd Screw, 1/2-13 x 1-1/4 in.
T53	Lock Washer, 1/2 in.
T65	Case Cap
T95	Bearing Spacer, 2.240 Wide
T122	Hydraulic Adapter, SAE Class B 2-Bolt
T128	Oil Seal, 1-3/8 x 2 x 5/16 in.
T129	Retaining Ring
T131	O-ring, 2-3/4 x 3 in.
T141	Gasket and O-ring Repair Kit

Hardware Torque Specifications

Screw Size	Torque Specification
5/16-18 UNC	17 lb-ft
3/8-16 UNC	31 lb-ft
1/2-13 UNC	75 lb-ft
1/2-20 UNF	85 lb-ft
5/8-11 UNC	150 lb-ft

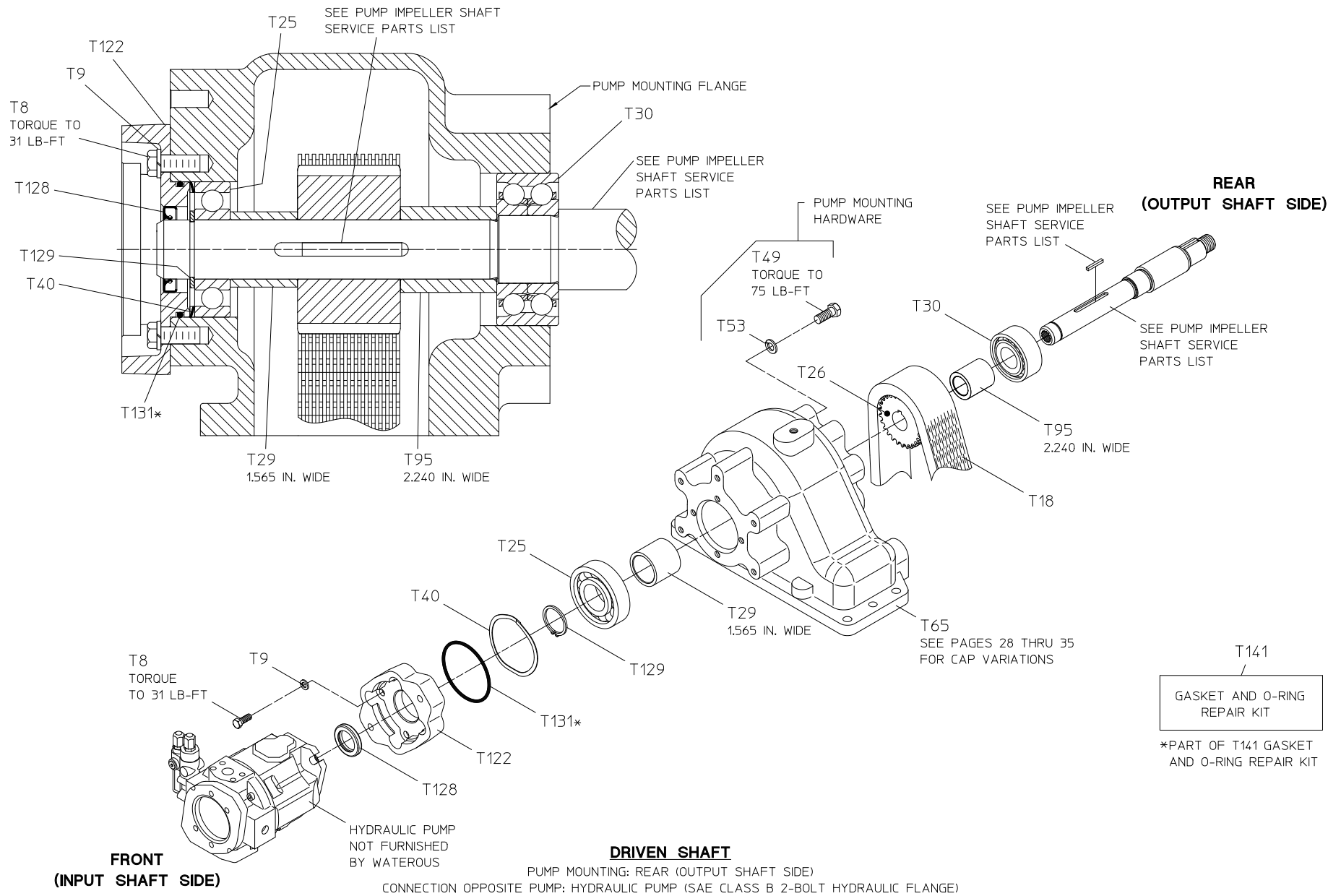

Drive Line - Input and Output Shafts (Exploded View)

REF. NO.	DESCRIPTION
T2	Coupling Shaft Spacer
T3	Single Row Ball Bearing
T4	Shift Collar
T5	Drive Sprocket
T6	Needle Bearing
T7	Thrust Washer
T8	Hex Hd Screw, 3/8-16 x 1 in.
T9	Lock Washer, 3/8 in.
T10	Tachometer Pulse Generator
T11	Drive Shaft Housing
T12	O-ring, 4-3/4 x 5 in.
T13	Drive Shaft
T14	Oil Seal, 3-1/2 x 4-3/8 in.
T15	Single Row Ball Bearing
T18	Chain
T26	Driven Sprocket
T36	Retaining Ring (Used Starting August 3, 2012)
T41	Wave Spring, 110 mm
T42	Coupling Shaft Housing

REF. NO.	DESCRIPTION
T43	Self-Locking Nut, 1-1/4-18 in.
T44	Coupling Shaft (Includes T36)
T46	Shoulder Screw, 5/8-11 x 2-1/2 in. (Self-Locking)
T68	Set Screw, 5/8-18 x 5/8 in.
T75	Shift Shoe
T80	Shift Fork
T83	Chain Connecting Pin Set
T94	Plain Washer, 1-1/4 in.
T108	Spirol Pin, 1/16 x 1/4 or 1/16 x 5/16 in.
T110	Magnetic Tachometer Pick-up
T111	O-ring, 5/8 x 3/4 in.
T141	Gasket and O-ring Kit
T142	Aluminum Shim

Hardware Torque Specifications

Screw Size	Torque Specification
5/16-18 UNC	17 lb-ft
3/8-16 UNC	31 lb-ft
1/2-13 UNC	75 lb-ft
1/2-20 UNF	85 lb-ft
5/8-11 UNC	150 lb-ft

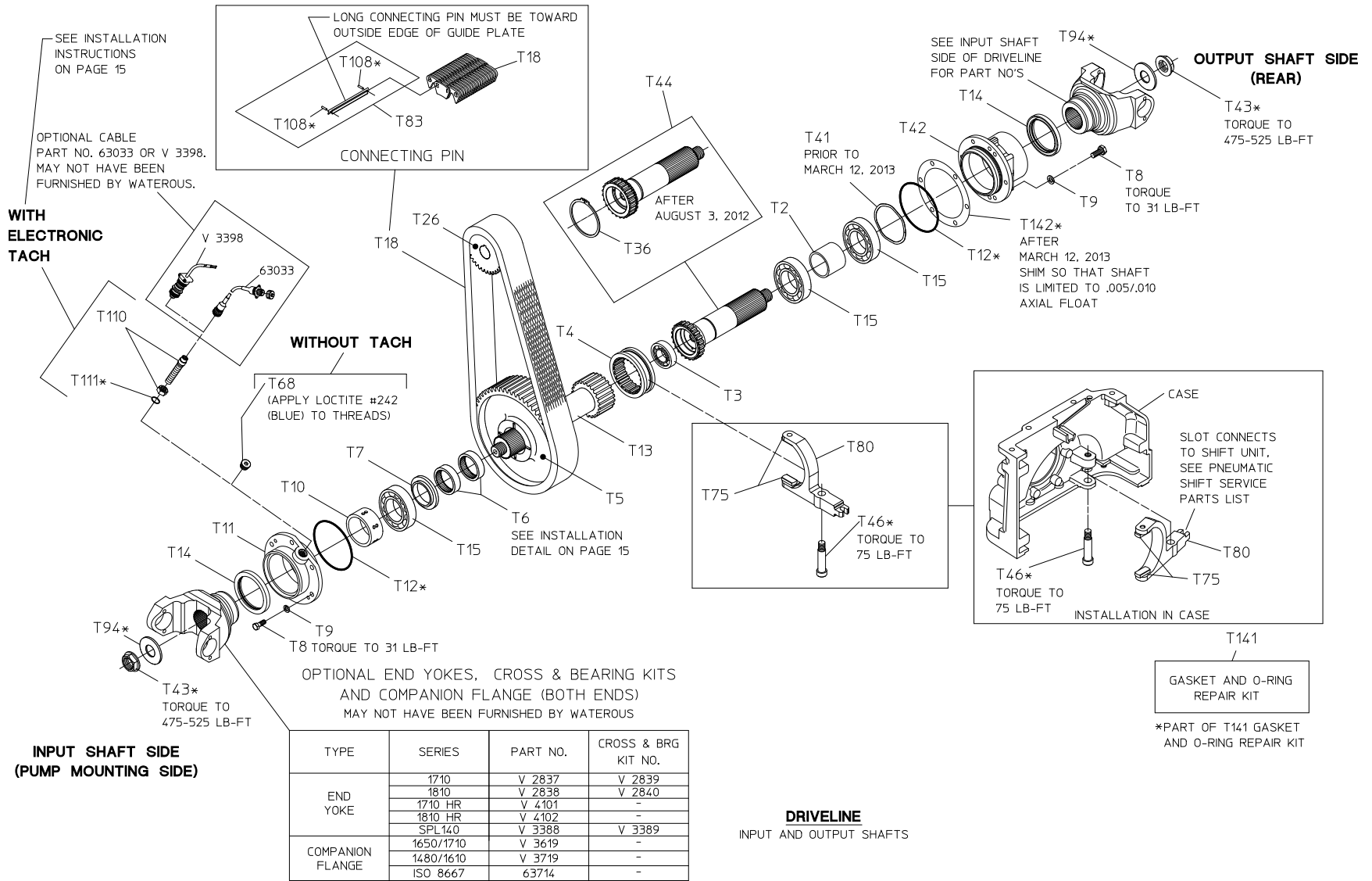

Drive Line - Input and Output Shafts (Cross-Section View)

REF. NO.	DESCRIPTION
T2	Coupling Shaft Spacer
T3	Single Row Ball Bearing
T4	Shift Collar
T5	Drive Sprocket
T6	Needle Bearing
T7	Thrust Washer
T8	Hex Hd Screw, 3/8-16 x 1 in.
T9	Lock Washer, 3/8 in.
T10	Tachometer Pulse Generator
T11	Drive Shaft Housing
T12	O-ring, 4-3/4 x 5 in.
T13	Drive Shaft
T14	Oil Seal, 3-1/2 x 4-3/8 in.
T15	Single Row Ball Bearing
T18	Chain
T36	Retaining Rin (Used Starting August 3, 2012)

REF. NO.	DESCRIPTION
T41	Wave Spring, 110 mm
T42	Coupling Shaft Housing
T43	Self-Locking Nut, 1-1/4-18 in.
T44	Coupling Shaft (Includes T36)
T46	Shoulder Screw, 5/8-11 x 2-1/2 in. (Self-Locking)
T68	Set Screw, 5/8-18 x 5/8 in.
T75	Shift Shoe
T80	Shift Fork
T94	Plain Washer, 1-1/4 in.
T110	Magnetic Tachometer Pick-up
T111	O-ring, 5/8 x 3/4 in.
T141	Gasket and O-ring Kit
T142	Aluminum Shim

Hardware Torque Specifications

Screw Size	Torque Specification
5/16-18 UNC	17 lb-ft
3/8-16 UNC	31 lb-ft
1/2-13 UNC	75 lb-ft
1/2-20 UNF	85 lb-ft
5/8-11 UNC	150 lb-ft

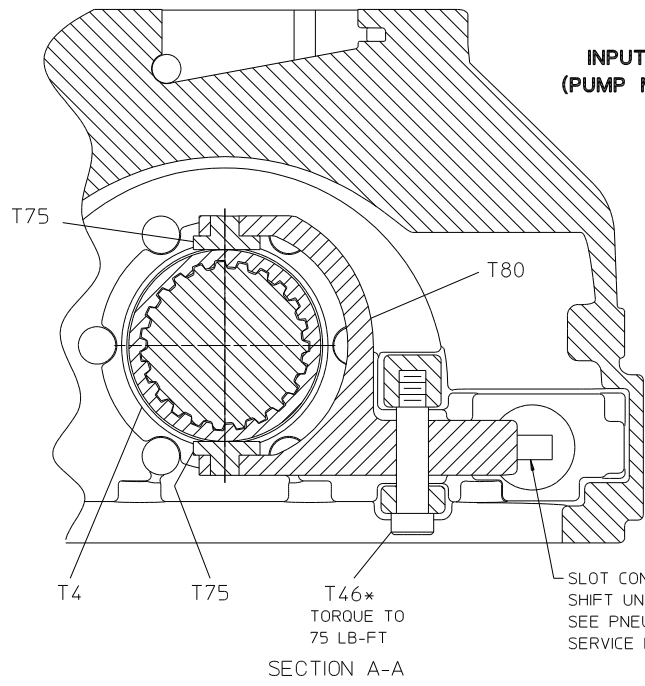
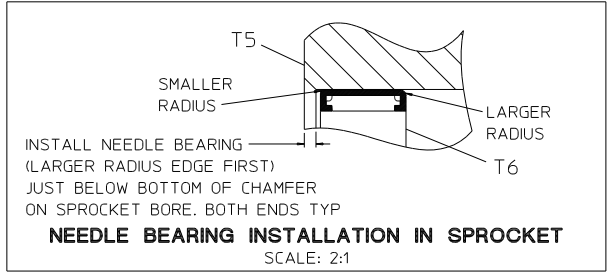
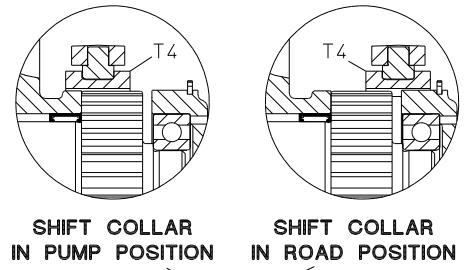
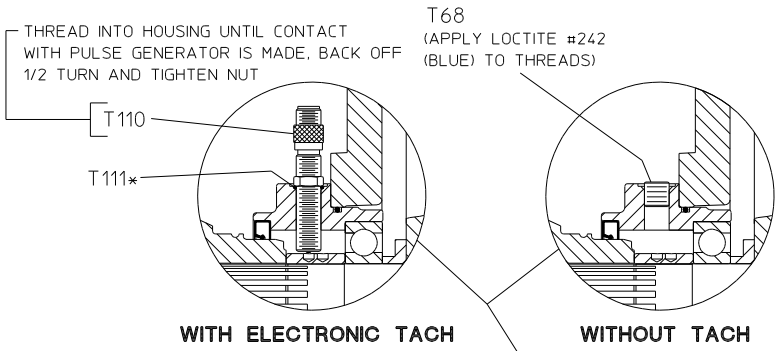

INPUT SHAFT SIDE (PUMP MOUNTING SIDE)

SLOT CONNECTS TO SHIFT UNIT. SEE PNEUMATIC SHIFT SERVICE PARTS LIST

OPTIONAL END YOKE OR COMPANION FLANGE. SEE PAGE 13 FOR PART NO'S MAY NOT HAVE BEEN FURNISHED BY WATEROUS

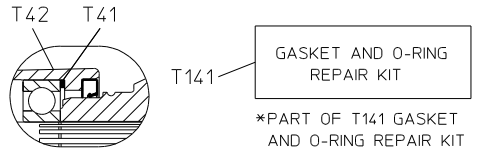
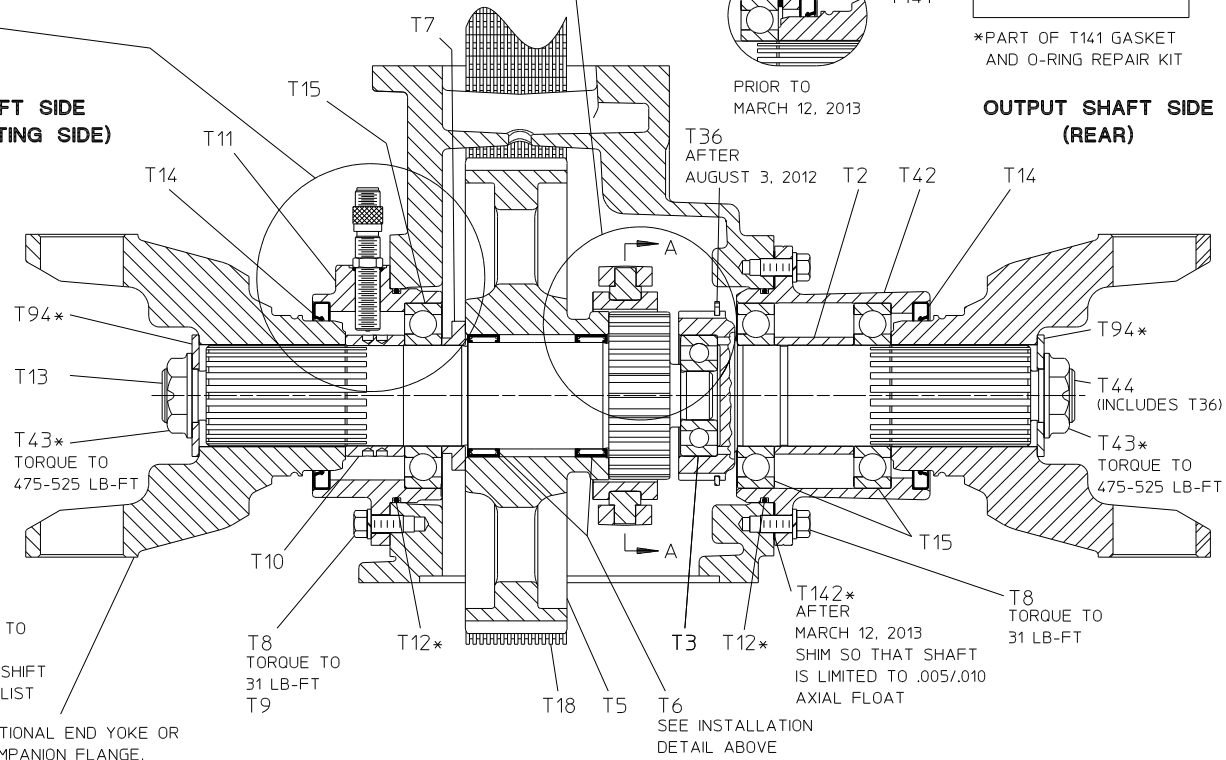

PRIOR TO MARCH 12, 2013

OUTPUT SHAFT SIDE (REAR)

GASKET AND O-RING REPAIR KIT

*PART OF T141 GASKET AND O-RING REPAIR KIT

DRIVELINE
INPUT AND OUTPUT SHAFTS

Drive Line - Input Shaft Only (Exploded View)

REF. NO.	DESCRIPTION
T3	Single Row Ball Bearing
T4	Shift Collar
T5	Drive Sprocket
T6	Needle Bearing
T7	Thrust Washer
T8	Hex Hd Screw, 3/8-16 x 1 in.
T9	Lock Washer, 3/8 in.
T10	Tachometer Pulse Generator
T11	Drive Shaft Housing
T12	O-ring, 4-3/4 x 5 in.
T13	Drive Shaft
T14	Oil Seal, 3-1/2 x 4-3/8 in.

REF. NO.	DESCRIPTION
T15	Single Row Ball Bearing
T18	Chain
T26	Driven Sprocket
T36	Retaining Ring
T41	Wave Spring, 72 mm
T42	Bearing Housing
T43	Self-Locking Nut, 1-1/4-18 in.
T68	Set Screw, 5/8-18 x 5/8 in.
T83	Chain Connecting Pin Set
T94	Plain Washer, 1-1/4 in.
T108	Spirol Pin, 1/16 x 1/4 or 1/16 x 5/16 in.
T110	Magnetic Tahcometer Pick-up
T111	O-ring, 5/8 x 3/4 in.
T141	Gasket and O-ring Repair Kit

Hardware Torque Specifications

Screw Size	Torque Specification
5/16-18 UNC	17 lb-ft
3/8-16 UNC	31 lb-ft
1/2-13 UNC	75 lb-ft
1/2-20 UNF	85 lb-ft
5/8-11 UNC	150 lb-ft

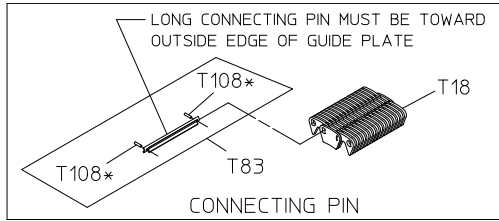

WITH ELECTRONIC TACH

SEE INSTALLATION INSTRUCTIONS ON PAGE 19

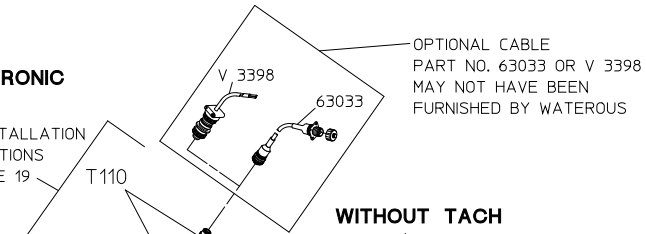

WITHOUT TACH

T68 (APPLY LOCTITE #242 (BLUE) TO THREADS)

OPTIONAL CABLE PART NO. 63033 OR V 3398 MAY NOT HAVE BEEN FURNISHED BY WATEROUS

INPUT SHAFT SIDE (PUMP MOUNTING SIDE)

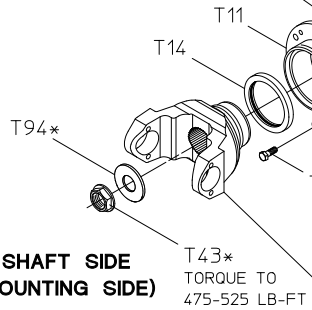

T43* TORQUE TO 475-525 LB-FT

OPTIONAL END YOKEs, CROSS & BEARING KITS AND COMPANION FLANGE (BOTH ENDS) MAY NOT HAVE BEEN FURNISHED BY WATEROUS

TYPE	SERIES	PART NO.	CROSS & BRG KIT NO.
END YOKE	1710 BP	V 2837	V 2839
	1810 BP	V 2838	V 2840
	1710 HR	V 4101	-
	1810 HR	V 4102	-
	SPL140	V 3388	V 3389
COMPANION FLANGE	1650/1710	V 3619	-
	1480/1610	V 3719	-
	ISO 8667	63714	-

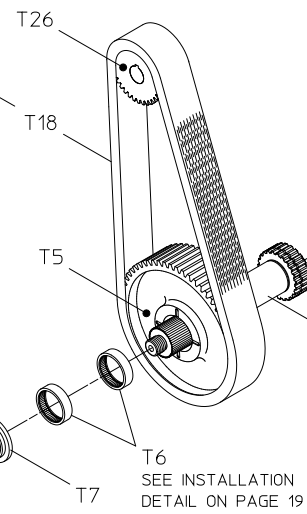

NO OUTPUT SHAFT (REAR)

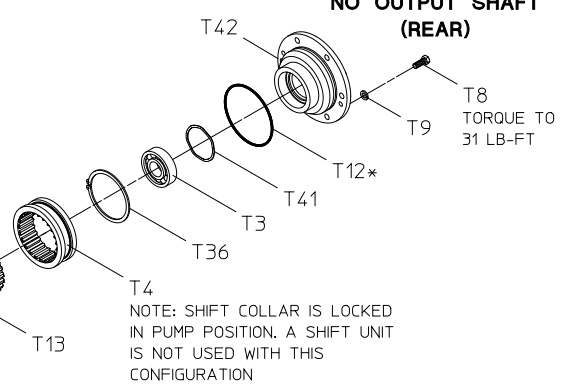

T8 TORQUE TO 31 LB-FT

NOTE: SHIFT COLLAR IS LOCKED IN PUMP POSITION. A SHIFT UNIT IS NOT USED WITH THIS CONFIGURATION

T141
GASKET AND O-RING REPAIR KIT

*PART OF T141 GASKET AND O-RING REPAIR KIT

DRIVELINE
INPUT SHAFT ONLY

Drive Line - Input Shaft Only (Cross-Section View)

REF. NO.	DESCRIPTION
T3	Single Row Ball Bearing
T4	Shift Collar
T5	Drive Sprocket
T6	Needle Bearing
T7	Thrust Washer
T8	Hex Hd Screw, 3/8-16 x 1 in.
T9	Lock Washer, 3/8 in.
T10	Tachometer Pulse Generator
T11	Drive Shaft Housing
T12	O-ring, 4-3/4 x 5 in.
T13	Drive Shaft
T14	Oil Seal, 3-1/2 x 4-3/8 in.

REF. NO.	DESCRIPTION
T15	Single Row Ball Bearing
T18	Chain
T36	Retaining Ring
T41	Wave Spring, 72 mm
T42	Bearing Housing
T43	Self-Locking Nut, 1-1/4-18 in.
T68	Set Screw, 5/8-18 x 5/8 in.
T94	Plain Washer, 1-1/4 in.
T110	Magnetic Tachometer Pick-up
T111	O-ring, 5/8 x 3/4 in.
T141	Gasket and O-ring Repair Kit

Hardware Torque Specifications

Screw Size	Torque Specification
5/16-18 UNC	17 lb-ft
3/8-16 UNC	31 lb-ft
1/2-13 UNC	75 lb-ft
1/2-20 UNF	85 lb-ft
5/8-11 UNC	150 lb-ft

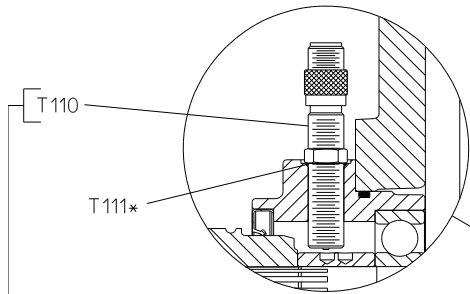

WITH ELECTRONIC TACH

THREAD INTO HOUSING UNTIL CONTACT WITH PULSE GENERATOR IS MADE. BACK OFF 1/2 TURN AND TIGHTEN NUT

T68
(APPLY LOCTITE #242 (BLUE) TO THREADS)

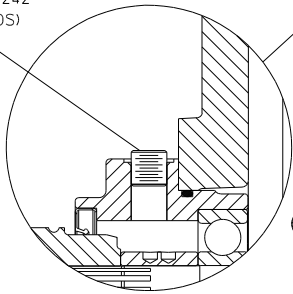

WITHOUT TACH

T141
GASKET AND O-RING REPAIR KIT

*PART OF T141 GASKET AND O-RING REPAIR KIT

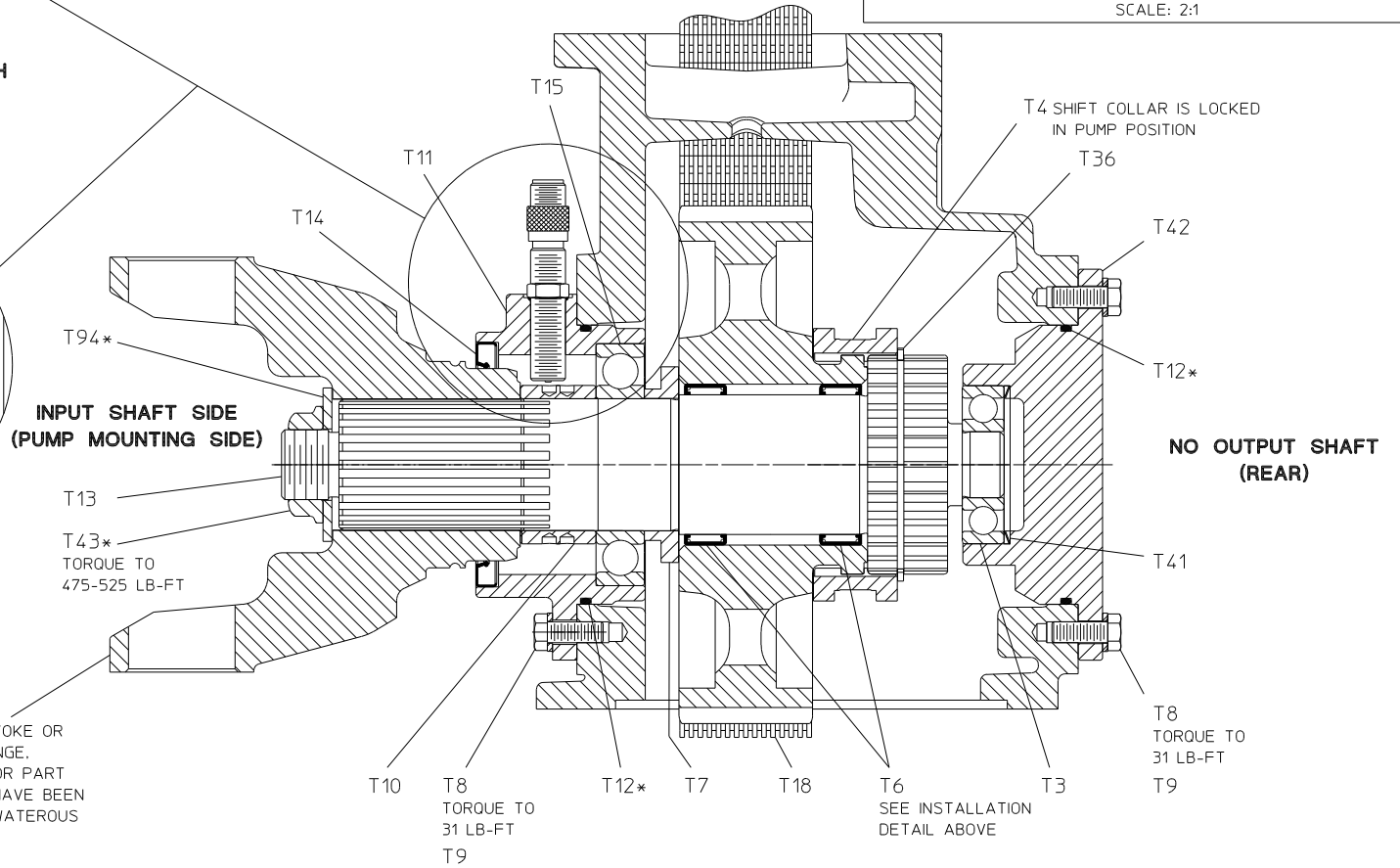
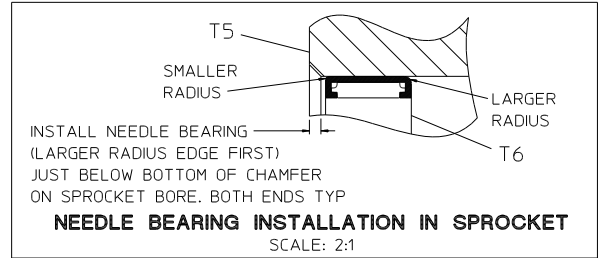

DRIVELINE
INPUT SHAFT ONLY

OPTIONAL END YOKE OR COMPANION FLANGE. SEE PAGE 17 FOR PART NO'S MAY NOT HAVE BEEN FURNISHED BY WATEROUS

Case

Viewed From Input Side

REF. NO.	DESCRIPTION
T8	Hex Hd Screw, 3/8-16 x 1 in.
T9	Lock Washer, 3/8 in.
T16	Transmission Pan
T17	Transmission Pan O-ring, 13 x 13-3/8

REF. NO.	DESCRIPTION
T27	Breather, 1/2 NPT
T28	Case
T81	Pipe Nipple, 1/2 NPT x 1-1/2 in.
T82	Pipe Coupling, 1/2 NPT
T141	Gasket and O-ring Repair Kit

Hardware Torque Specifications

Screw Size	Torque Specification
5/16-18 UNC	17 lb-ft
3/8-16 UNC	31 lb-ft
1/2-13 UNC	75 lb-ft
1/2-20 UNF	85 lb-ft
5/8-11 UNC	150 lb-ft

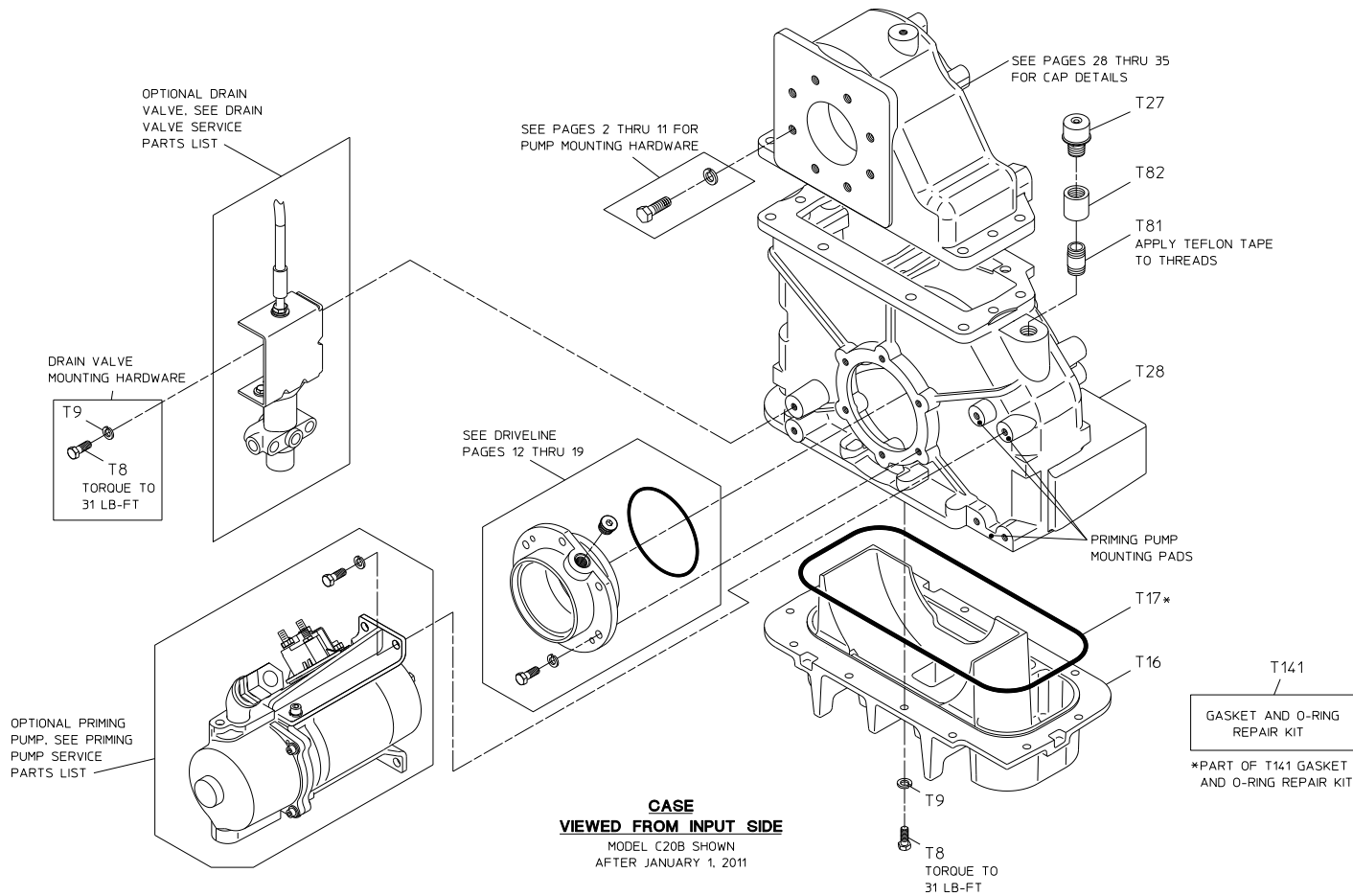

Case

Viewed from Input Side

REF. NO.	DESCRIPTION
T8	Hex Hd Screw, 3/8-16 x 1 in.
T9	Lock Washer, 3/8 in.
T16	Transmission Pan (Includes T84 and T85)
T17	Transmission Pan Gasket

REF. NO.	DESCRIPTION
T27	Breather, 1/2 NPT
T28	Case
T81	Pipe Nipple, 1/2 NPT x 1-1/2 in.
T82	Pipe Coupling, 1/2 NPT
T84	Tube Connector
T85	Cooling Tube, 3/8 in.
T141	Gasket and O-ring Repair Kit

Hardware Torque Specifications

Screw Size	Torque Specification
5/16-18 UNC	17 lb-ft
3/8-16 UNC	31 lb-ft
1/2-13 UNC	75 lb-ft
1/2-20 UNF	85 lb-ft
5/8-11 UNC	150 lb-ft

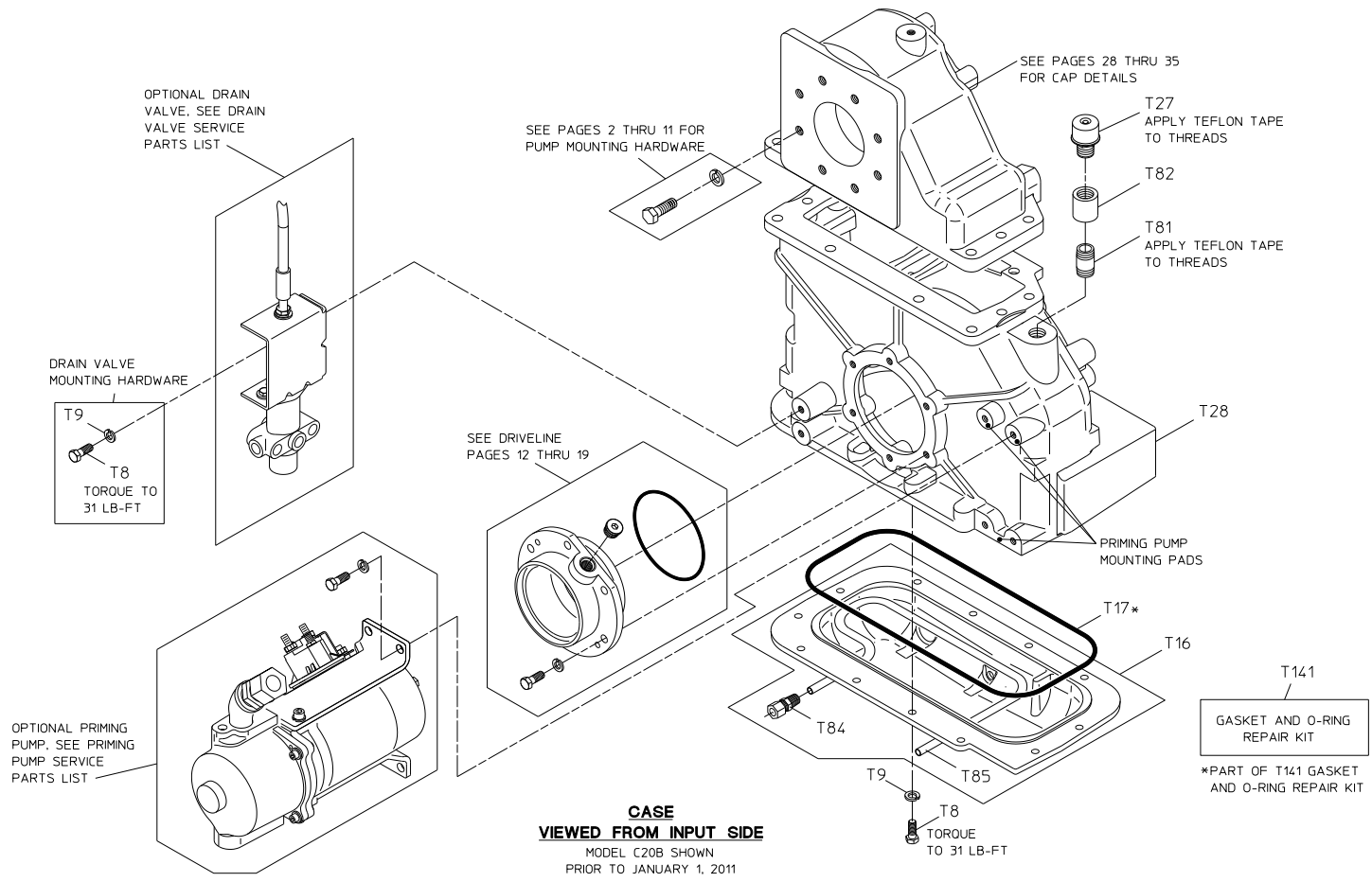

CASE
VIEWED FROM INPUT SIDE
 MODEL C20B SHOWN
 PRIOR TO JANUARY 1, 2011

Case

Viewed from Output Side

REF. NO.	DESCRIPTION
T8	Hex Hd Screw, 3/8-16 x 1 in.
T9	Lock Washer, 3/8 in.
T16	Transmission Pan
T17	Transmission Pan O-ring, 13 x 13-3/8
T28	Case
T57	Magnetic Drain Plug, 3/4-16 (Includes T78)

REF. NO.	DESCRIPTION
T61	Pipe Plug, 1/2 NPT
T77	Headless Pipe Plug, 1/8 NPT
T78	O-ring, 16.4 mm x 20.8 mm
T134	Sight Plug, 3/4 NPT
T141	Gasket and O-ring Repair Kit

Hardware Torque Specifications

Screw Size	Torque Specification
5/16-18 UNC	17 lb-ft
3/8-16 UNC	31 lb-ft
1/2-13 UNC	75 lb-ft
1/2-20 UNF	85 lb-ft
5/8-11 UNC	150 lb-ft

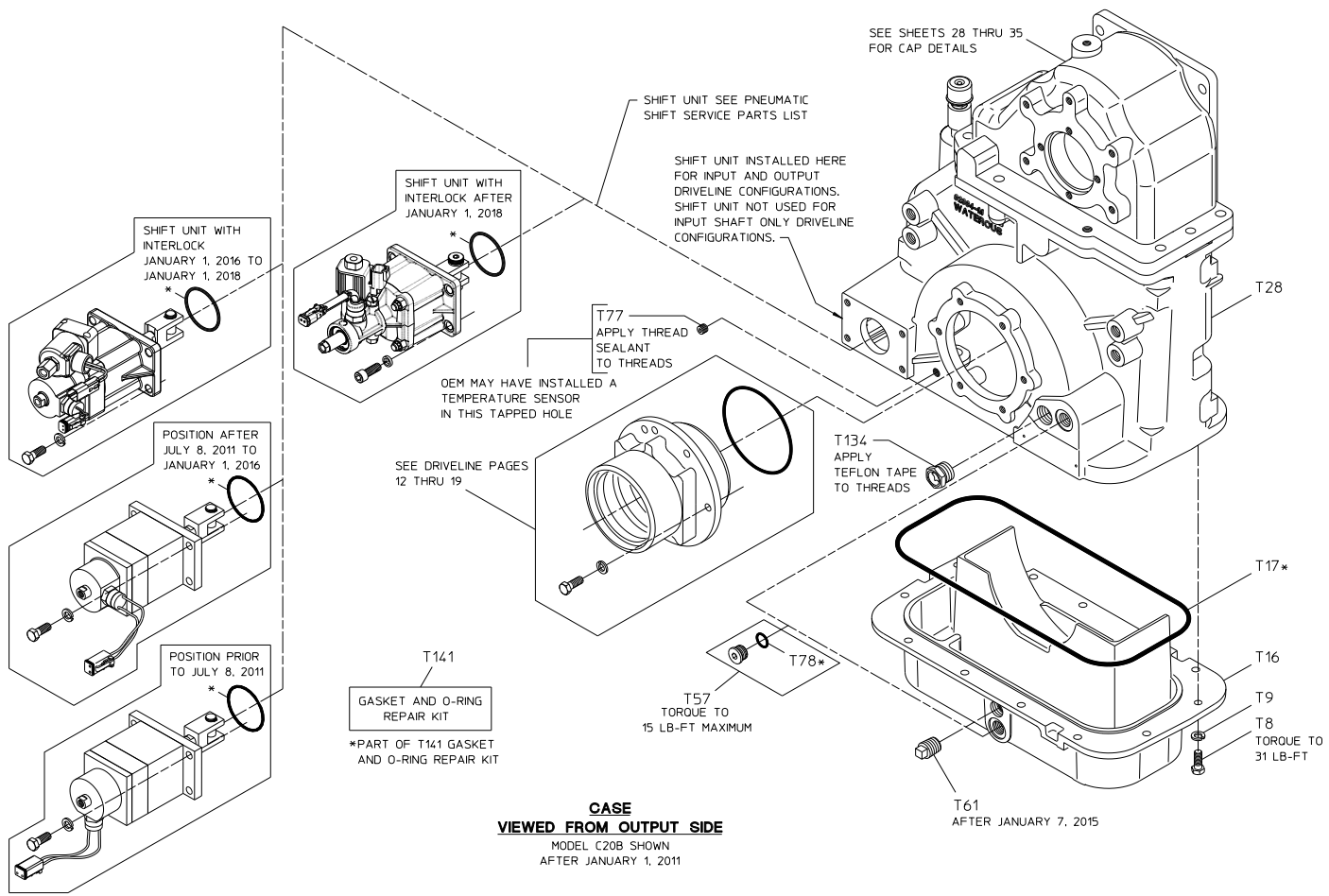

Case

Viewed from Output Side

REF. NO.	DESCRIPTION
T8	Hex Hd Screw, 3/8-16 x 1 in.
T9	Lock Washer, 3/8 in.
T16	Transmission Pan (Includes T84 and T85)
T17	Transmission Pan Gasket
T28	Case

REF. NO.	DESCRIPTION
T57	Magnetic Drain Plug, 3/4-16 (Includes T78)
T77	Headless Pipe Plug, 1/8 NPT
T78	O-ring, 16.4 mm x 20.8 mm
T84	Tube Connector
T85	Cooling Tube, 3/8 in.
T134	Sight Plug, 3/4 NPT
T141	Gasket and O-ring Repair Kit

Hardware Torque Specifications

Screw Size	Torque Specification
5/16-18 UNC	17 lb-ft
3/8-16 UNC	31 lb-ft
1/2-13 UNC	75 lb-ft
1/2-20 UNF	85 lb-ft
5/8-11 UNC	150 lb-ft

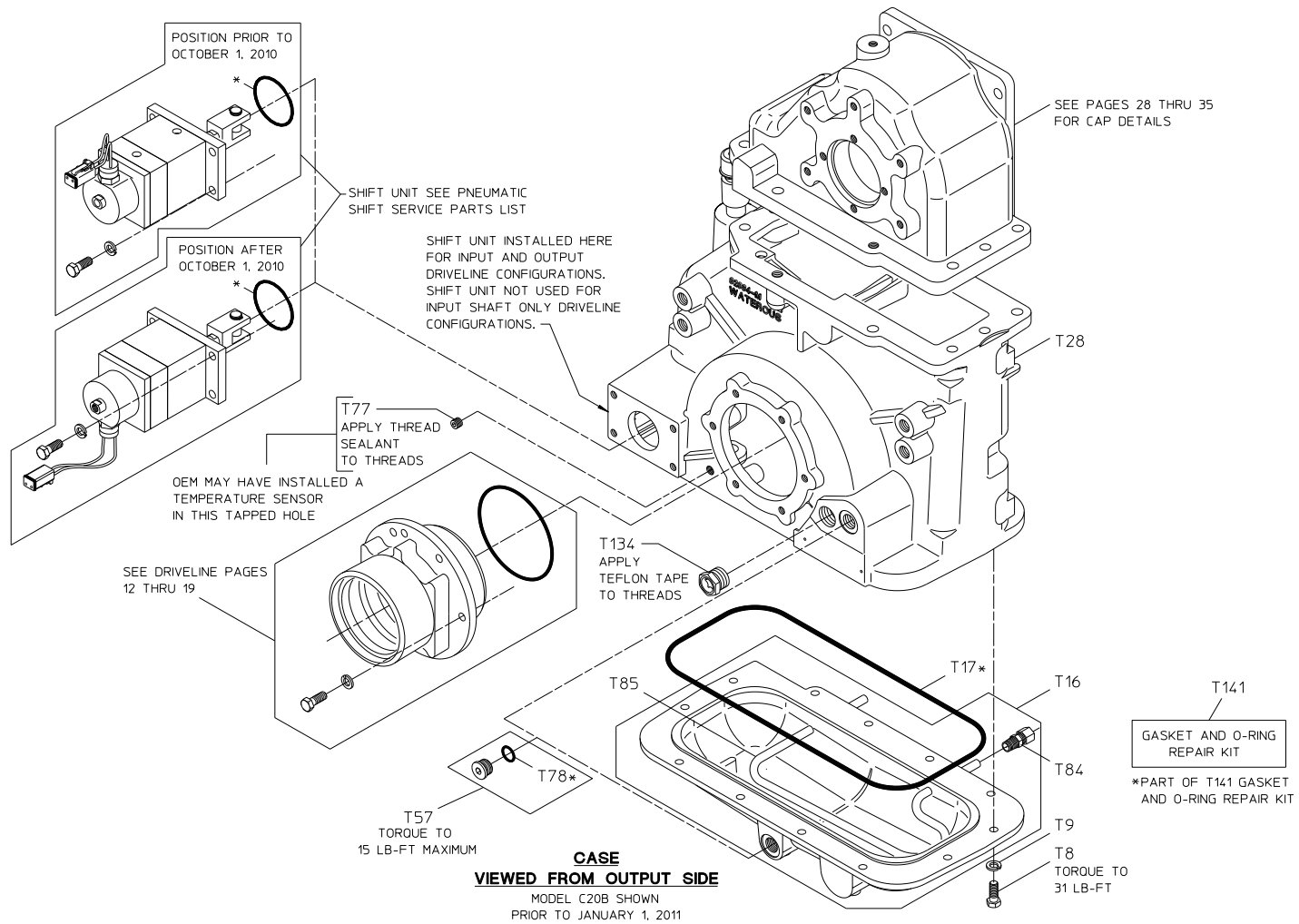

Case Cap Variations - Spacers, Shims and Sealant Application

Models C20B, C20C, C20D, C20E and C20F

REF. NO.	DESCRIPTION
T28	Case
T64	Oil Return Tube
T65	Case Cap

REF. NO.	DESCRIPTION
T99	Shim
T100	Case Spacer

APPLY LOCTITE® 518 SEALANT OR EQUIVALENT TO MATING FLANGES AND BETWEEN SHIMS

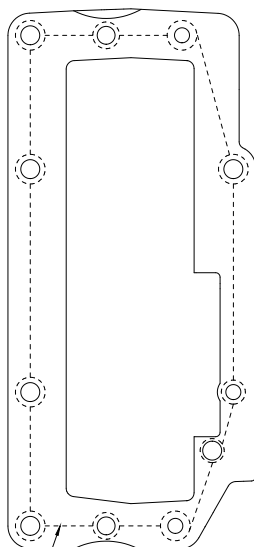

APPLY A THIN BEAD OF SEALANT AS SHOWN BY DASHED LINE (CASE FLANGE SHOWN)

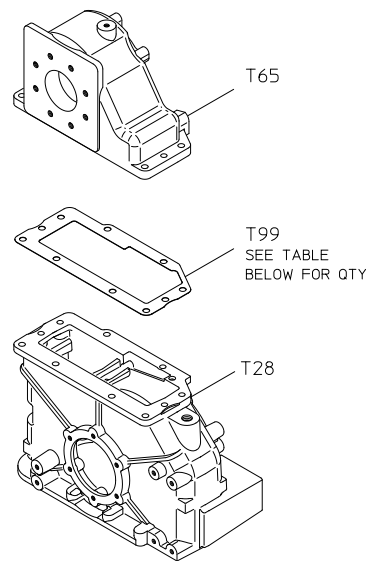

MODEL C20B

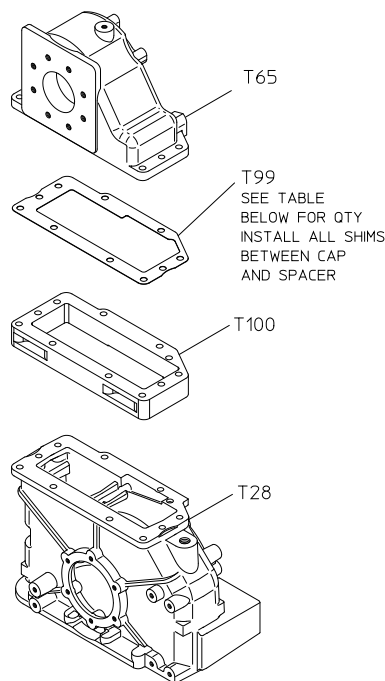

MODEL C20C

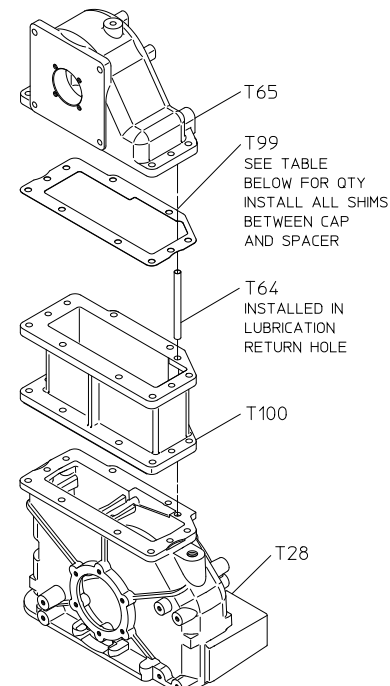

MODEL C20D, C20E & C20F

RATIO	QTY OF T99 SHIMS														
	MODEL C20B			MODEL C20C			MODEL C20D			MODEL C20E			MODEL C20F		
	.010 BROWN	.025 WHITE	.031 ORANGE	.010 BROWN	.025 WHITE	.031 ORANGE	.010 BROWN	.025 WHITE	.031 ORANGE	.010 BROWN	.025 WHITE	.031 ORANGE	.010 BROWN	.025 WHITE	.031 ORANGE
1.27	N/A	N/A	N/A	3	7	2	1	0	2	2	0	1	0	0	1
1.41	0	0	0	1	2	0	0	3	0	2	0	1	0	0	1
1.48	4	2	1	3	2	2	2	0	1	0	0	1	1	0	0
1.58	0	0	0	2	0	0	1	1	0	2	0	0	0	0	0
1.69	1	3	0	0	0	0	2	0	0	2	0	3	0	4	0
1.79	0	0	2	0	0	0	1	0	0	3	2	1	2	2	1
1.88	2	0	0	1	0	0	2	0	0	1	1	1	2	0	1
1.97	2	2	1	0	0	1	0	1	1	0	2	0	1	0	1
2.03	0	0	0	1	1	0	0	0	2	2	0	0	4	1	0
2.27	1	1	0	0	3	0	0	0	0	0	0	0	0	0	0
2.46	2	1	0	0	1	2	0	1	0	2	1	3	2	1	3
2.68	1	2	0	1	0	0	4	0	0	3	1	0	0	0	2

CASE ASSEMBLY, SPACERS AND SHIMS

Case Cap Variations - Hardware

Model C20B

REF. NO.	DESCRIPTION
T51	Hex Hd Screw, 1/2-13 x 1-1/2 in.
T53	Lock Washer, 1/2 in.
T69	Hex Nut, 1/2-20

REF. NO.	DESCRIPTION
T72	Hex Hd Screw, 1/2-20 x 2-1/4 in.
T103	Dowel Pin, 1/2 x 1-1/2 in.

Hardware Torque Specifications

Screw Size	Torque Specification
5/16-18 UNC	17 lb-ft
3/8-16 UNC	31 lb-ft
1/2-13 UNC	75 lb-ft
1/2-20 UNF	85 lb-ft
5/8-11 UNC	150 lb-ft

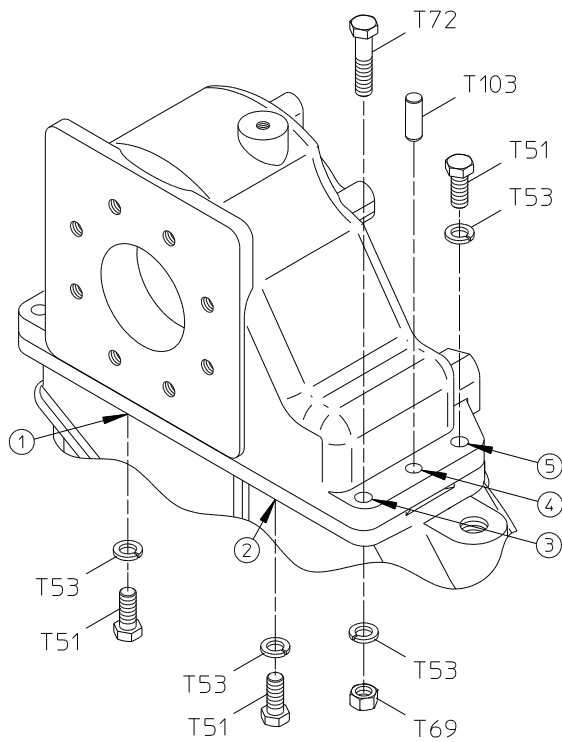

VIEWED FROM INPUT SIDE OF CASE

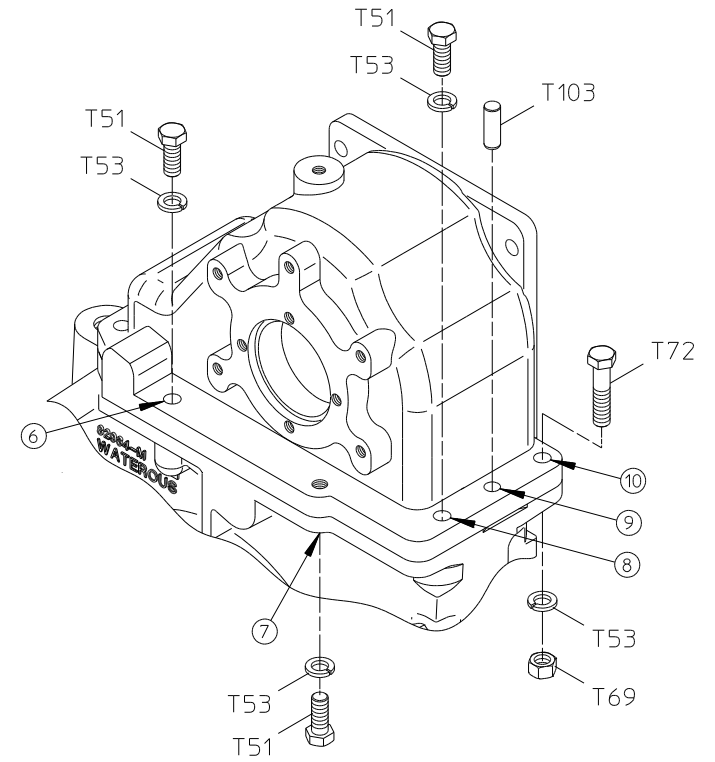

VIEWED FROM OUTPUT SIDE OF CASE

FLANGE HARDWARE BETWEEN CAP (T65) AND CASE (T28)

REF NO.	HARDWARE DESCRIPTION	HOLE NUMBER										QTY	TORQUE SPECIFICATION
		1	2	3	4	5	6	7	8	9	10		
T51	SCREW-HEX HD, 1/2-13 X 1.50	1	1			1	1	1	1			6	75 LB-FT
T53	WASHER-LOCK, 1/2	1	1	1		1	1	1	1		1	8	-
T69	NUT-HEX, 1/2-20				1						1	2	-
T72	SCREW-HEX HD, 1/2-20 X 2.25				1						1	2	85 LB-FT
T103	PIN-DOWEL, 1/2 X 1-1/2					1				1	2		-

NOTE:

1. HOLES 1 AND 2 ARE BLIND HOLES THAT ARE TAPPED INTO THE CAP AND ARE NOT SHOWN.

**CASE CAP VARIATIONS
HARDWARE FOR MODEL C20B**

Case Cap Variations - Hardware

Model C20C

REF. NO.	DESCRIPTION
T53	Lock Washer, 1/2 in.
T54	Hex Hd Screw, 1/2-13 x 3-1/2 in.
T55	Hex Hd Screw, 1/2-13 x 3-3/4 in.
T69	Hex Nut, 1/2-20

REF. NO.	DESCRIPTION
T73	Hex Hd Screw, 1/2-20 x 4 in.
T74	Hex Hd Screw, 1/2-20 x 4-1/4 in.
T104	Dowel Pin, 1/2 x 3 in.

Hardware Torque Specifications

Screw Size	Torque Specification
5/16-18 UNC	17 lb-ft
3/8-16 UNC	31 lb-ft
1/2-13 UNC	75 lb-ft
1/2-20 UNF	85 lb-ft
5/8-11 UNC	150 lb-ft

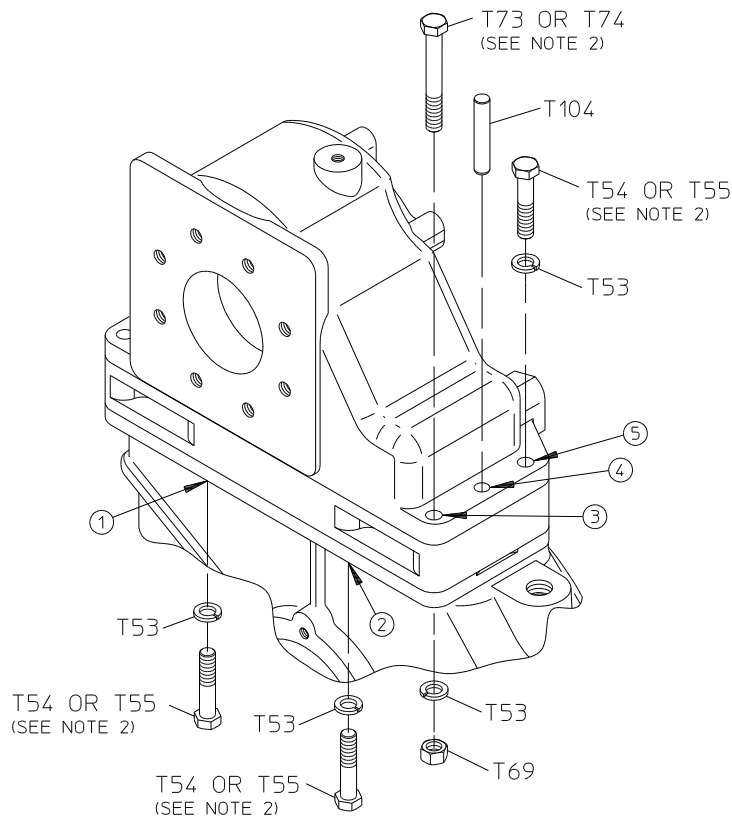

VIEWED FROM INPUT SIDE OF CASE

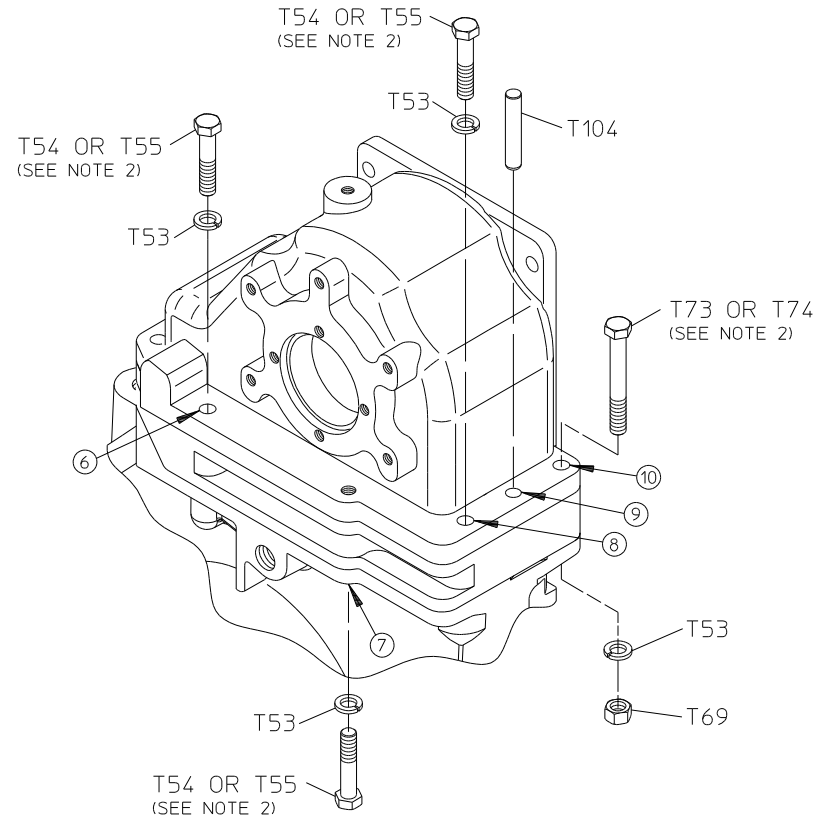

VIEWED FROM OUTPUT SIDE OF CASE

FLANGE HARDWARE BETWEEN CAP (T65), SPACER (T100) AND CASE (T28)

REF NO.	HARDWARE DESCRIPTION	HOLE NUMBER										QTY	TORQUE SPECIFICATION
		1	2	3	4	5	6	7	8	9	10		
T53	WASHER-LOCK, 1/2	1	1	1		1	1	1	1		1	8	-
T54	SCREW-HEX HD, 1/2-13 X 3.50	1	1			1	1	1	1			6	75 LB-FT
T55	SCREW-HEX HD, 1/2-13 X 3.75 (SEE NOTE 2)	1	1			1	1	1	1			6	75 LB-FT
T69	NUT-HEX, 1/2-20			1							1	2	-
T73	SCREW-HEX HD, 1/2-20 X 4.00			1							1	2	85 LB-FT
T74	SCREW-HEX HD, 1/2-20 X 4.25 (SEE NOTE 2)			1							1	2	85 LB-FT
T104	PIN-DOWEL, 1/2 X 3.00				1					1		2	-

**CASE CAP VARIATIONS
HARDWARE FOR MODEL C20C**

- NOTES:
 1. HOLES 1 AND 2 ARE BLIND HOLES THAT ARE TAPPED INTO THE CAP AND ARE NOT SHOWN.
 2. T55 & T74 USED ON 1.27 RATIO ONLY.
 T54 & T73 IS USED ON ALL OTHER RATIOS.

Case Cap Variations - Hardware

Model C20D, C20E and C20F

REF. NO.	DESCRIPTION
T51	Hex Hd Screw, 1/2-13 x 1-1/2 in.
T53	Lock Washer, 1/2 in.
T69	Hex Nut, 1/2-20

REF. NO.	DESCRIPTION
T71	Hex Hd Screw, 1/2-20 x 2 in.
T103	Dowel Pin, 1/2 x 1-1/2 in.

Hardware Torque Specifications

Screw Size	Torque Specification
5/16-18 UNC	17 lb-ft
3/8-16 UNC	31 lb-ft
1/2-13 UNC	75 lb-ft
1/2-20 UNF	85 lb-ft
5/8-11 UNC	150 lb-ft

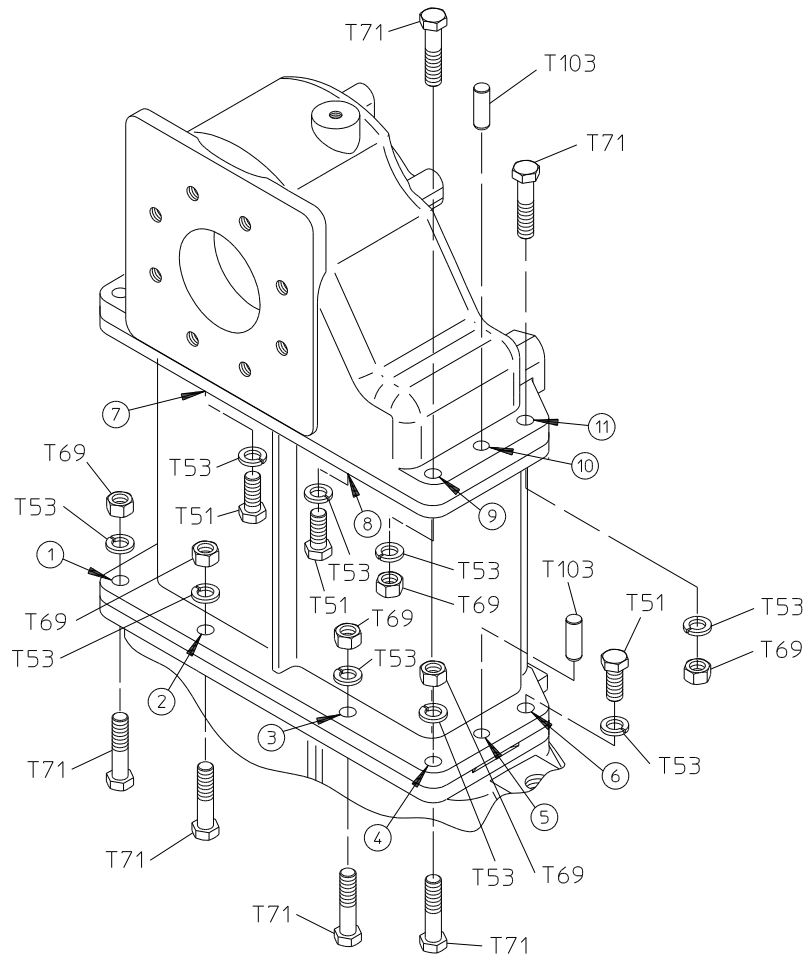

VIEWED FROM INPUT SIDE OF CASE

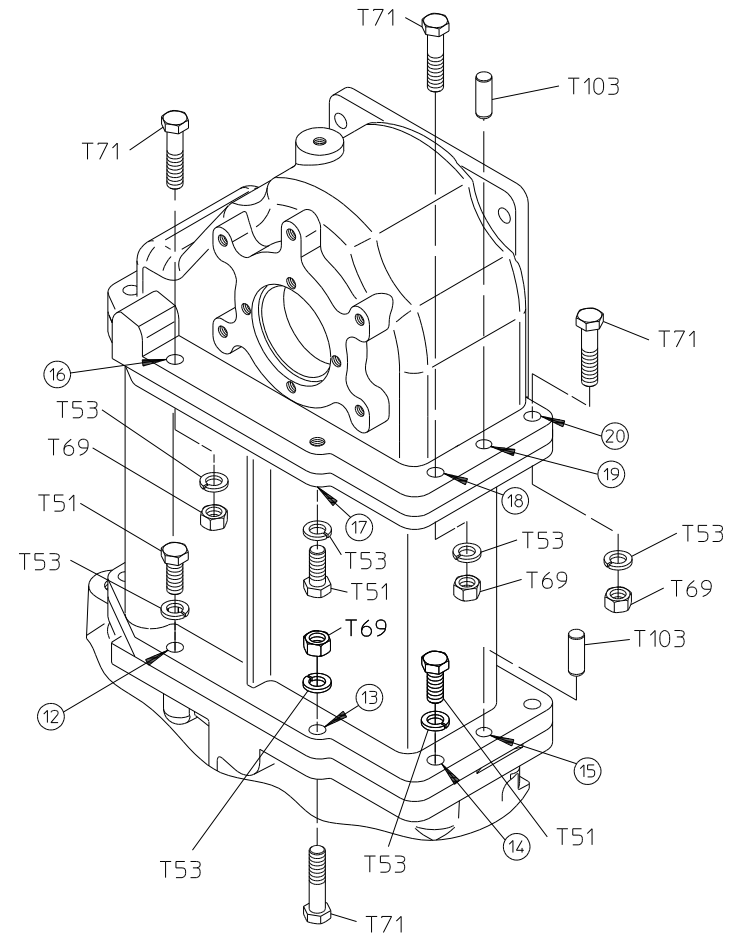

VIEWED FROM OUTPUT SIDE OF CASE

FLANGE HARDWARE BETWEEN CAP (T65), SPACER (T100) AND CASE (T28)

REF NO.	HARDWARE DESCRIPTION	HOLE NUMBER																				QTY	TORQUE SPECIFICATION
		1	2	3	4	5	6	7	8	9	10	11	12	13	14	15	16	17	18	19	20		
T51	SCREW-HEX HD, 1/2-13 X 1.50						1	1	1			1	1			1	1					6	75 LB-FT
T53	WASHER-LOCK, 1/2	1	1	1	1		1	1	1	1		1	1	1	1		1	1	1		1	16	-
T69	NUT-HEX, 1/2-20	1	1	1	1					1		1	1			1		1		1		10	-
T71	SCREW-HEX HD, 1/2-20 X 2.00	1	1	1	1					1		1	1			1		1		1		10	85 LB-FT
T103	PIN-DOWEL, 1/2 X 1-1/2					1					1					1				1		4	-

NOTE:

1. HOLES 7 AND 8 ARE BLIND HOLES THAT ARE TAPPED INTO THE CAP AND ARE NOT SHOWN.

**CASE CAP VARIATIONS
HARDWARE FOR MODELS C20D, C20E & C20F**