



Document Number	Issue Date	Rev. Date
SPL 83158	09/27/11	06/07/13

HL Series Fire Pump Control Panel Service Parts List

Index:

Pump Model <i>(Located on Pump Serial Plate)</i>			Control Panel Installed on Pump	See Pages									
HL200 Series	HL300 Series	HL400 Series		Control Panel									Optional Gages and Monitors
				Mounting on Pump	Panel Components	Gauge and Wiring Connections						Wiring Schematic	
						Compound Gauge	Pump Overheat Module	Normal Pressure Gauge	High Pressure Gauge	Tachometer Hourmeter			
HL200D HL200K	HL300D HL300K	HL400D HL400K	Yes	2, 3	4, 5	6, 7	6, 7	8, 9	8, 9	10, 11	12, 13	-	
			No	-	-	-	-	-	-	-	-	14, 15	

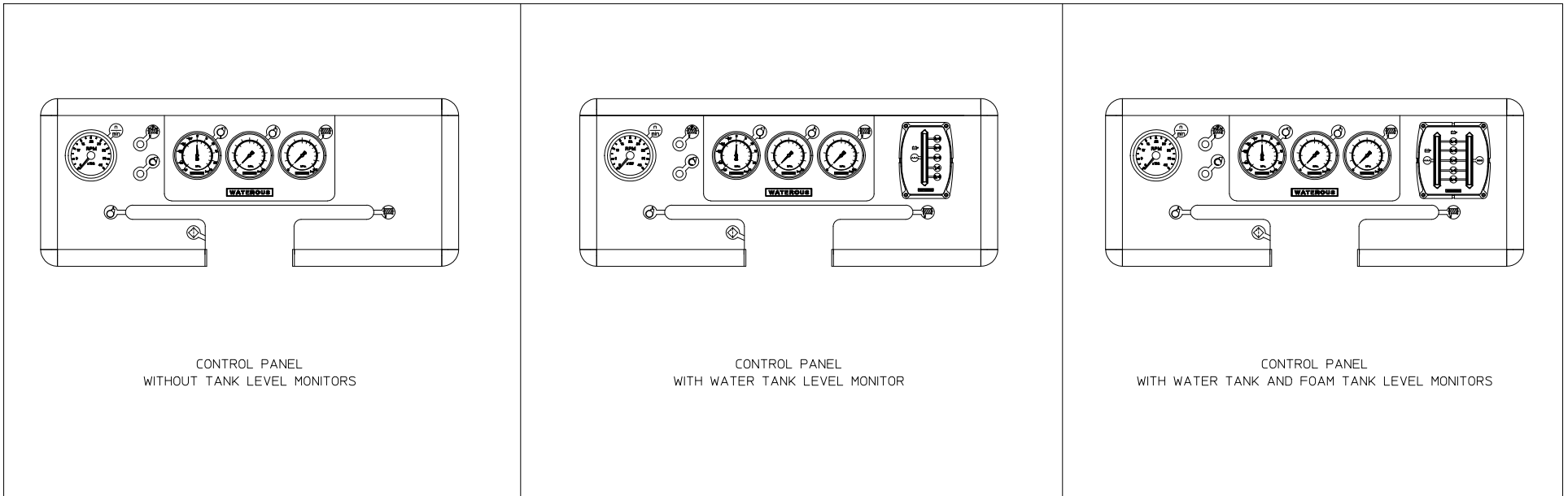

Mounting on Pump

REF. NO.	DESCRIPTION
500	Panel Assembly (Also See Page 5)
501	Mounting Bracket

REF. NO.	DESCRIPTION
502	Hex Head Screw, M10 x 1.50 x 20 mm
503	Lock Washer, 10 mm

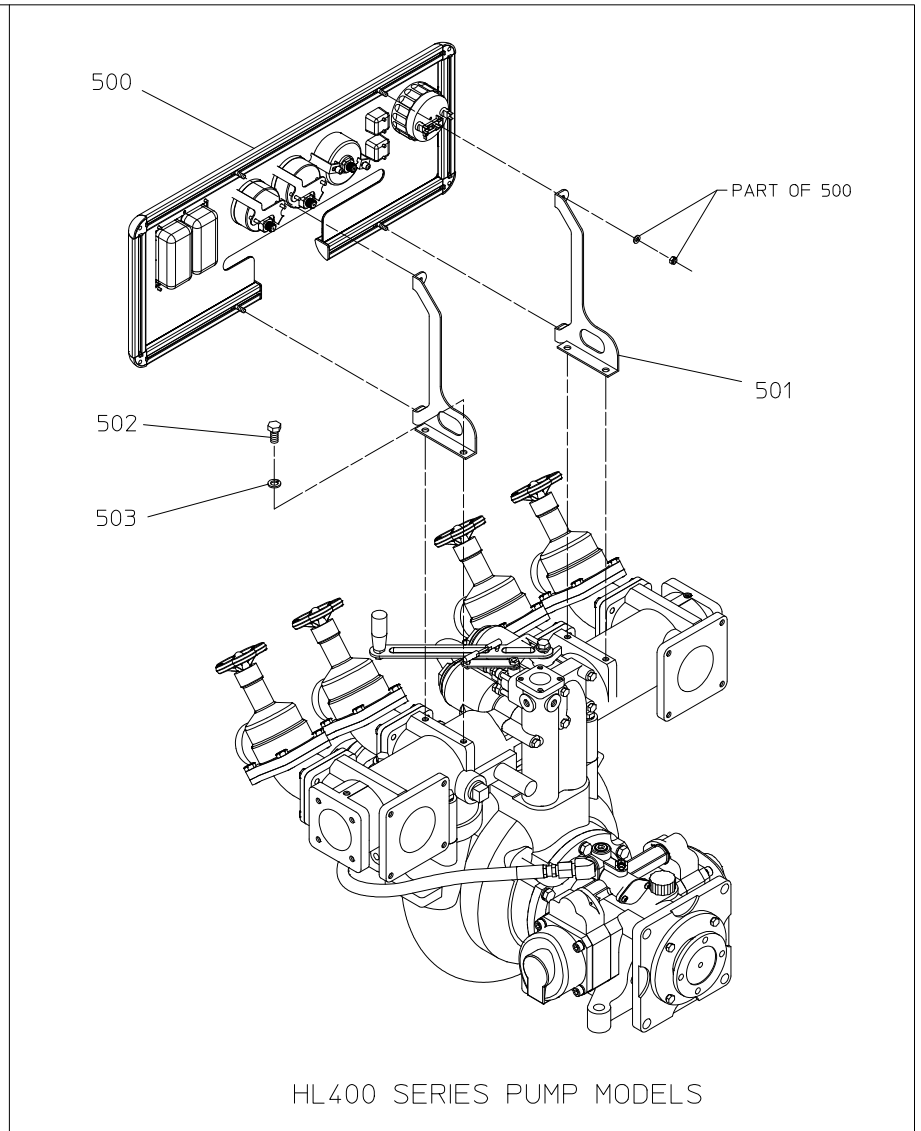
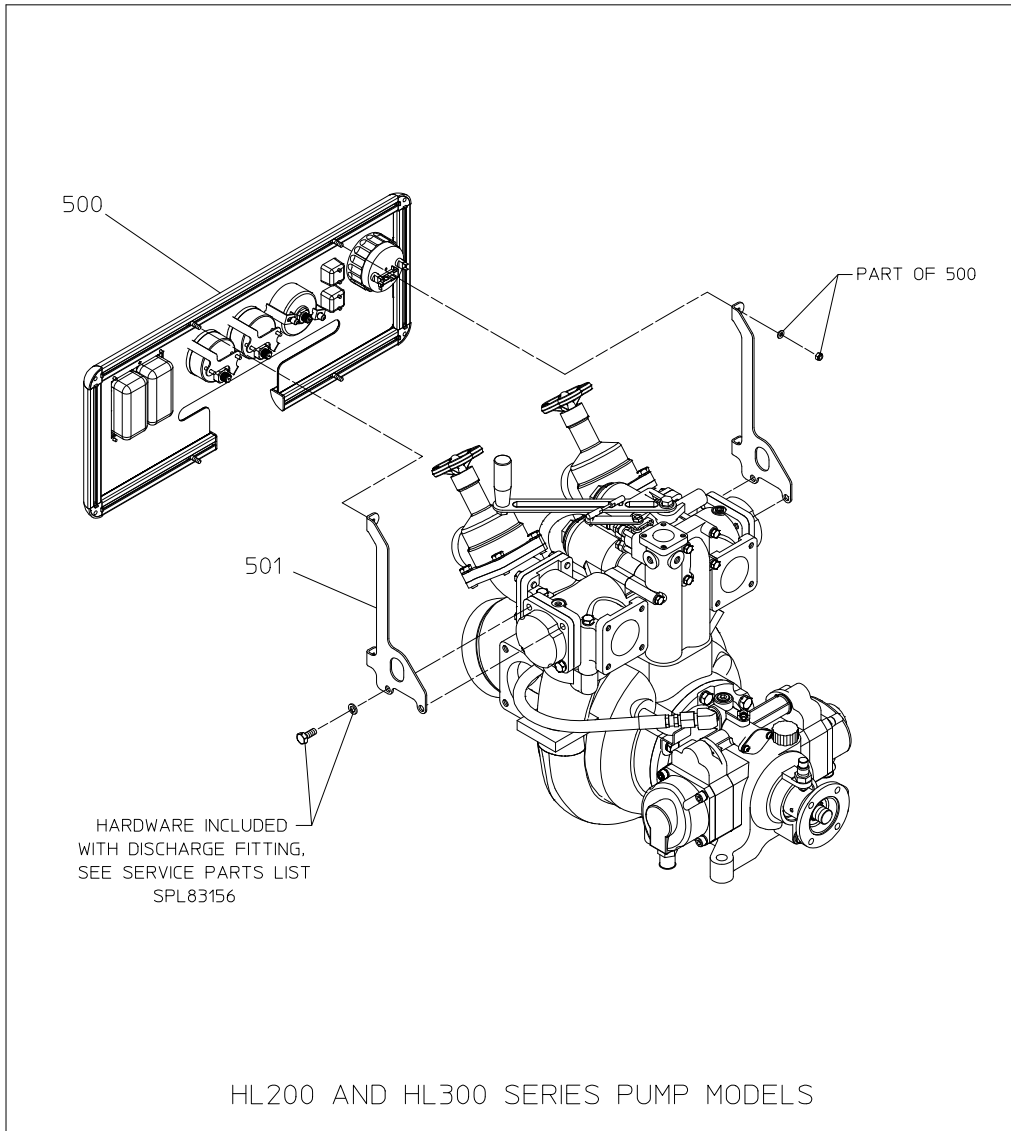

MOUNTING ON PUMP

Panel Components

REF. NO.	DESCRIPTION
500	Panel Assembly (Includes 504 and 509 Through 530)
508	Tachometer/Hourmeter Gauge
513	Pump Engaged Wiring Harness (Green LED)
517	High Temp Switch Wiring Harness (Red LED)
519	Elbow, 90 Degree, 1/4 in. NSPT x 1/4 in. NPT
520	Tank Level Monitor Wiring Harness
521	Tank Level Monitor Sender
522	Single Tank Monitor Display Panel (Includes Mounting Hardware)

REF. NO.	DESCRIPTION
523	Dual Tank Monitor Display Panel (Includes Mounting Hardware)
524	Type E Wedge Base Light Bulb
525	Compound Gauge
526	High Pressure Gauge
527	Normal Pressure Gauge
529	Pump Engaged Indicator Module (Green LED)
530	Pump Overheat Indicator Module (Red LED)

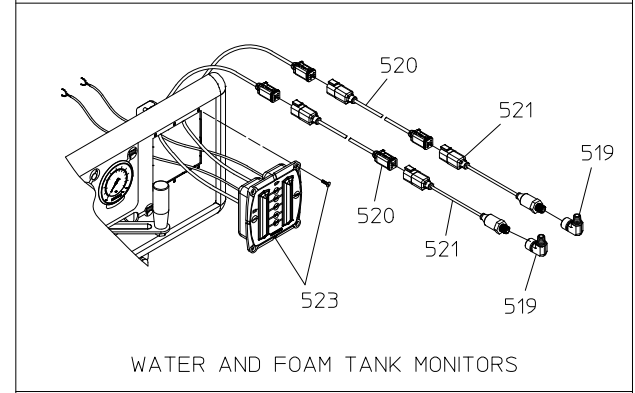
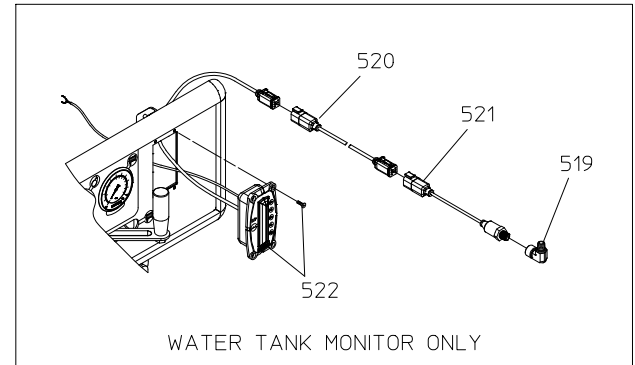
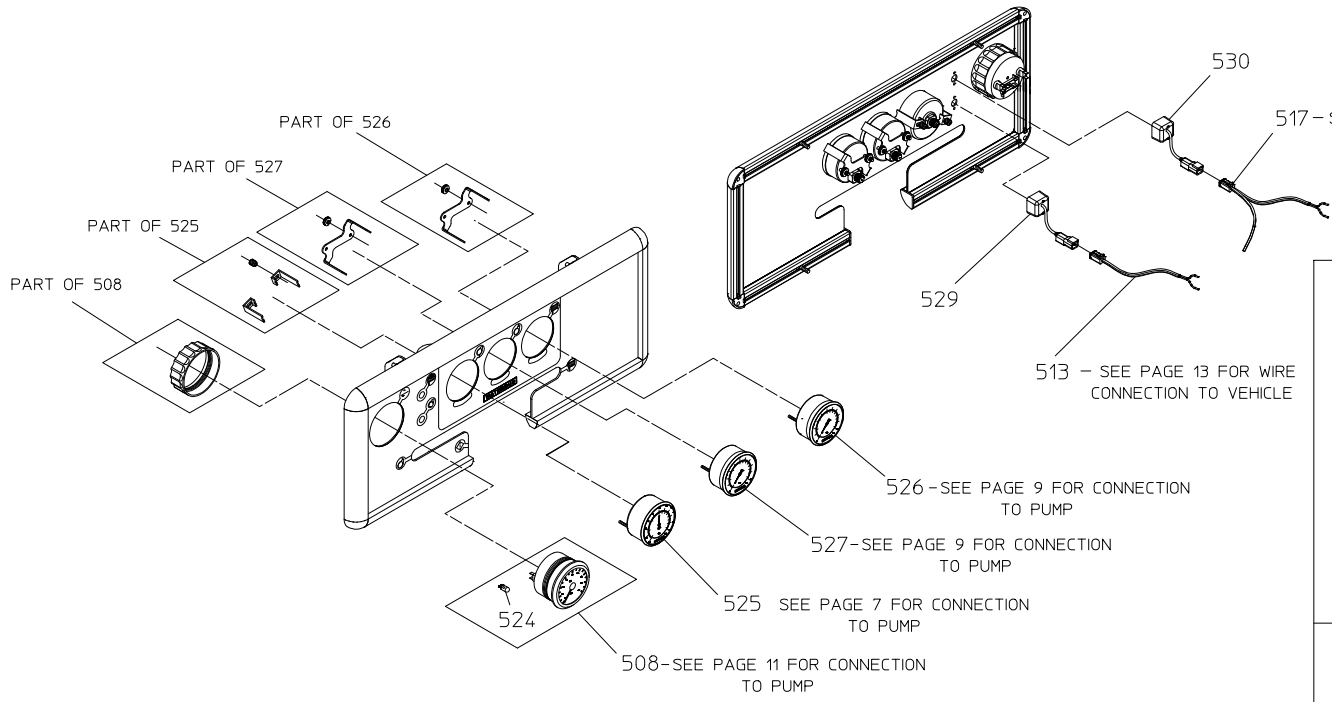

OPTIONAL TANK LEVEL MONITORS

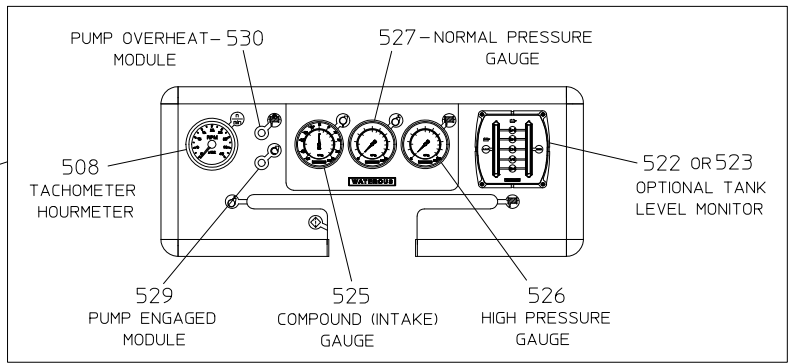

PANEL COMPONENTS

Gauge and Wiring Connections – Compound (Intake) Gauge and Pump Overheat Module

REF. NO.	DESCRIPTION
47	Interstage Manifold (See Service Parts Lists SPL83155 or SPL83161)
86	Intake Adapter (See Service Parts Lists SPL83155 or SPL83161)
510	Straight Push-In Fitting, 6 mm Tube x 1/4 in. BSPT
511	Reducing Bushing, 1/4 in. BSPT (F) x 1/2 NPT (M)
512	Temperature Switch, Series 48T

REF. NO.	DESCRIPTION
515	Fitting, 6 mm Tube x 1/4 in. NPT (Brass)
517	High Temp Switch Wiring Harness (Red LED)
525	Compound Gauge
530	Pump Overheat Indicator Module (Red LED)

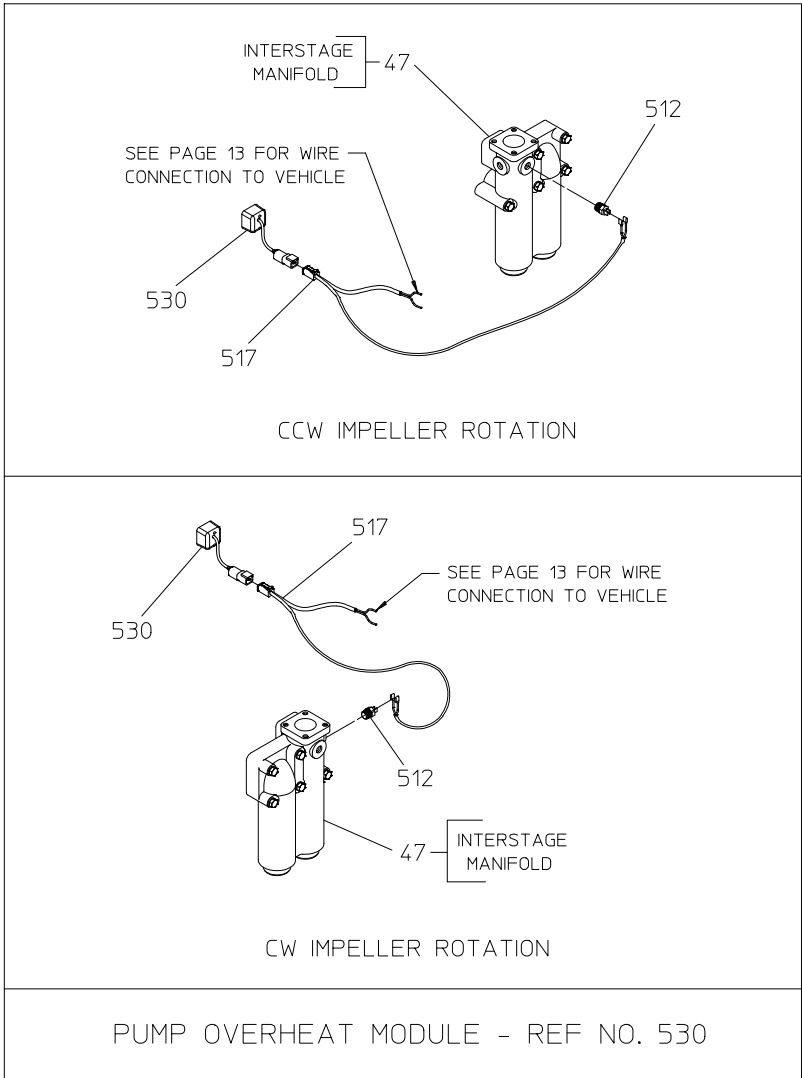
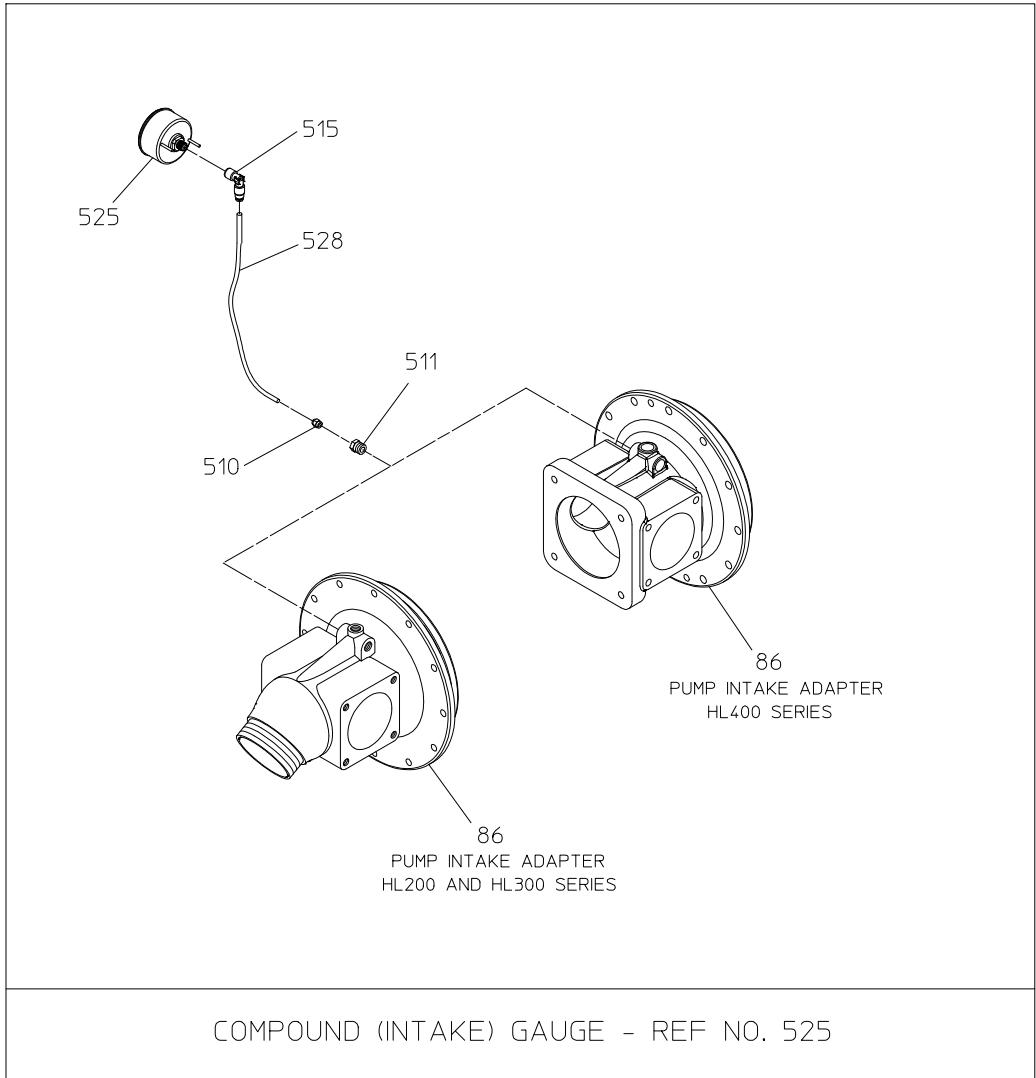

GAUGE AND WIRING CONNECTIONS -
COMPOUND (INTAKE) GAUGE AND PUMP OVERHEAT MODULE

Gauge and Wiring Connections – Normal and High Pressure Gauges

REF. NO.	DESCRIPTION
47	Interstage Manifold (See Service Parts Lists SPL83155 or SPL83161)
80	Discharge Manifold (See Service Parts Lists SPL83155 or SPL83161)
504	Stainless Steel Tubing, 6 mm
509	Elbow, 90 Degree, 6 mm Tube x 1/4 in. BSPT
510	Straight Push-In Fitting, 6 mm Tube x 1/4 in. BSPT

REF. NO.	DESCRIPTION
515	Brass Fitting, 6 mm Tube x 1/4 in. NPT
516	Stainless Steel Fitting, 6 mm Tube x 1/4 in. NPT
526	High Pressure Gauge
527	Normal Pressure Gauge
528	Blue Nylon Tubing , 6 mm x 24 in. Long

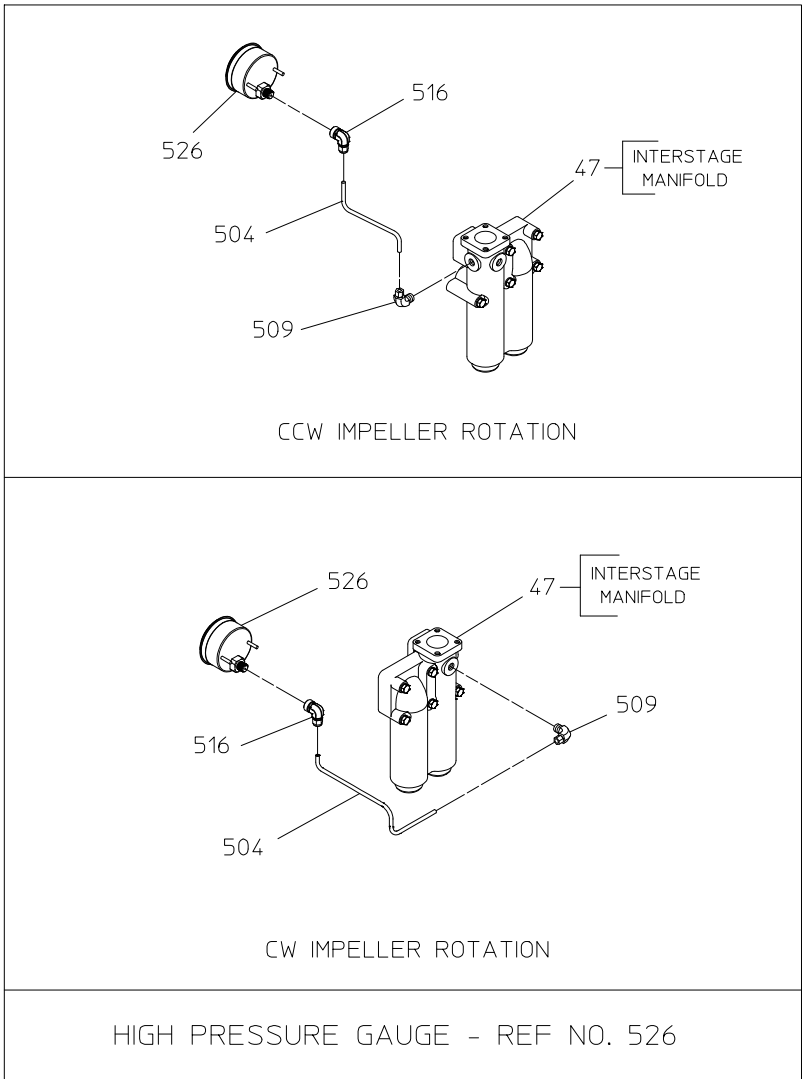
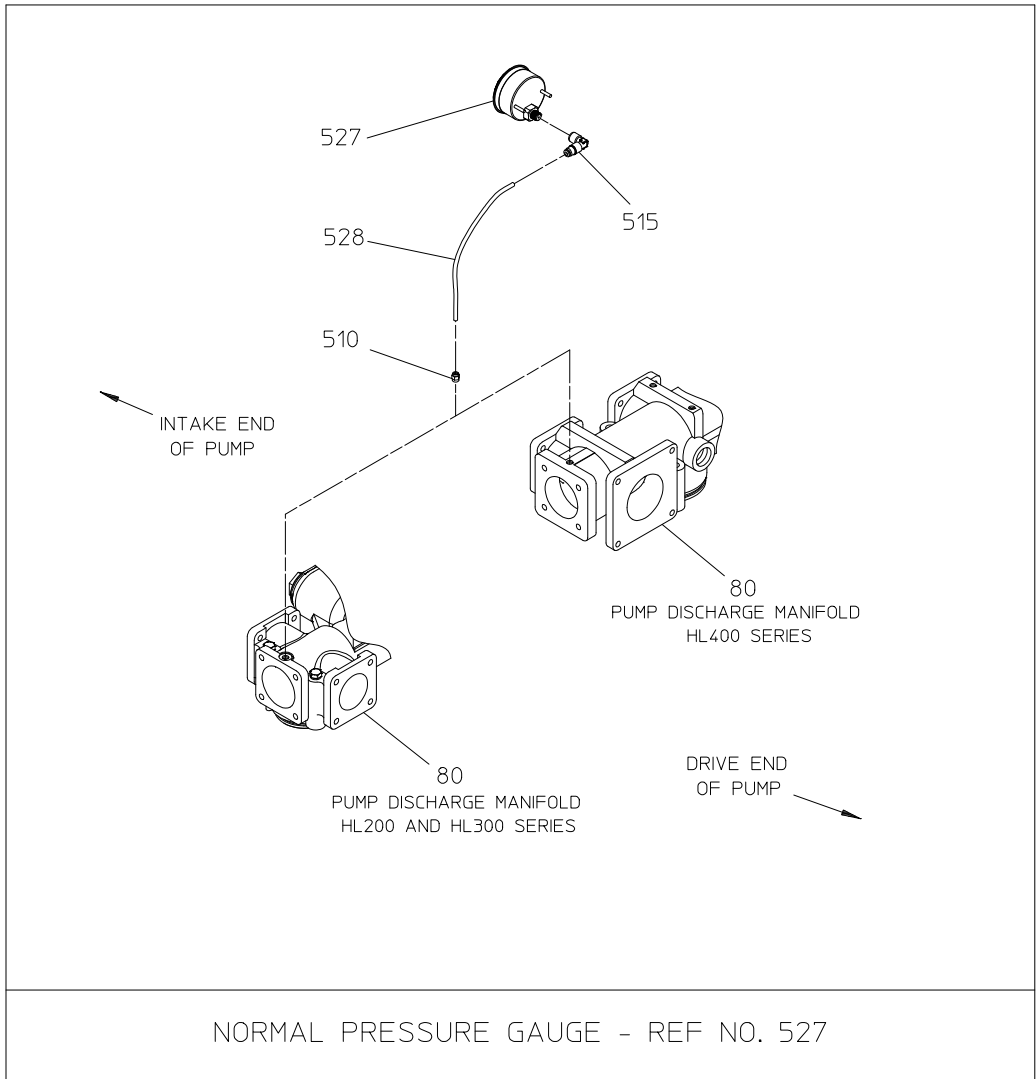

GAUGE AND WIRING CONNECTIONS -
NORMAL AND HIGH PRESSURE GAUGES

Gauge and Wiring Connections – Tachometer / Hourmeter

REF. NO.	DESCRIPTION
508	Tachometer/Hourmeter Gauge

REF. NO.	DESCRIPTION
518	Tachometer Wiring Harness

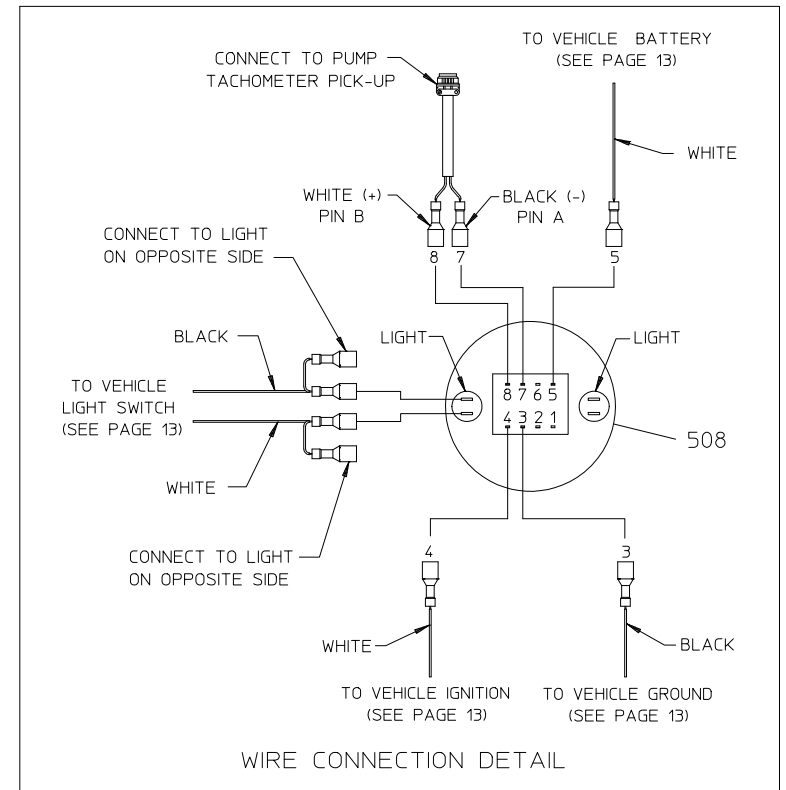
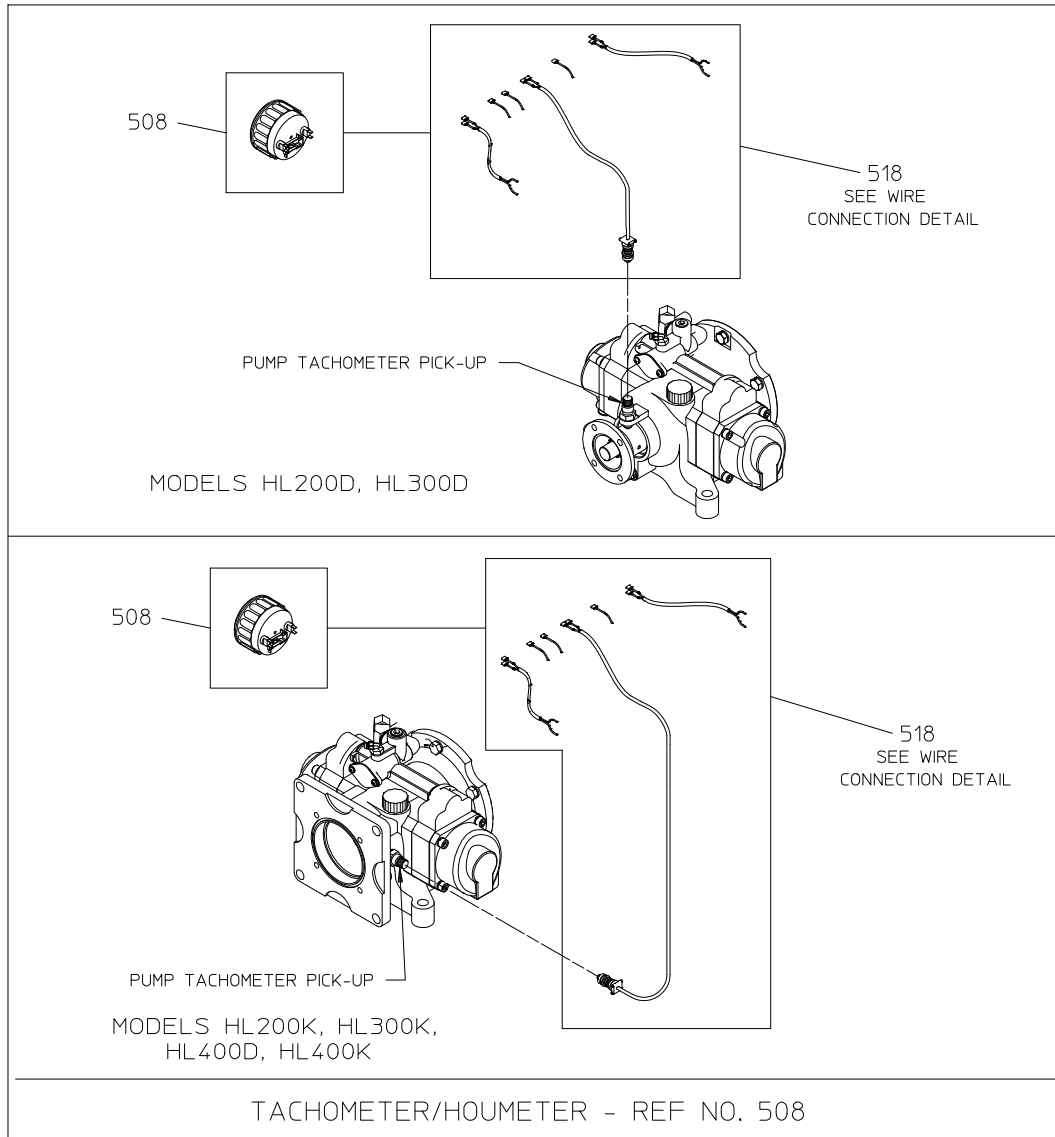

GAUGE AND WIRING CONNECTIONS – TACHOMETER/HOURMETER

Wiring Schematic

REF. NO.	DESCRIPTION
508	Tachometer/Hourmeter Gauge
512	Temperature Switch, Series 48T
513	Pump Engaged Wiring Harness (Green LED)
517	High Temp Switch Wiring Harness (Red LED)
518	Tachometer Wiring Harness
519	Elbow, 90 Degree, 1/4 in. BSPT x 1/4 NPT
521	Tank Level Monitor Sender

REF. NO.	DESCRIPTION
522	Single Tank Monitor Display Panel (Includes Mounting Hardware)
523	Dual Tank Monitor Display Panel (Includes Mounting Hardware)
525	Compound Gauge
526	High Pressure Gauge
527	Normal Pressure Gauge
529	Pump Engaged Indicator Module (Green LED)
530	Pump Overheat Indicator Module (Red LED)

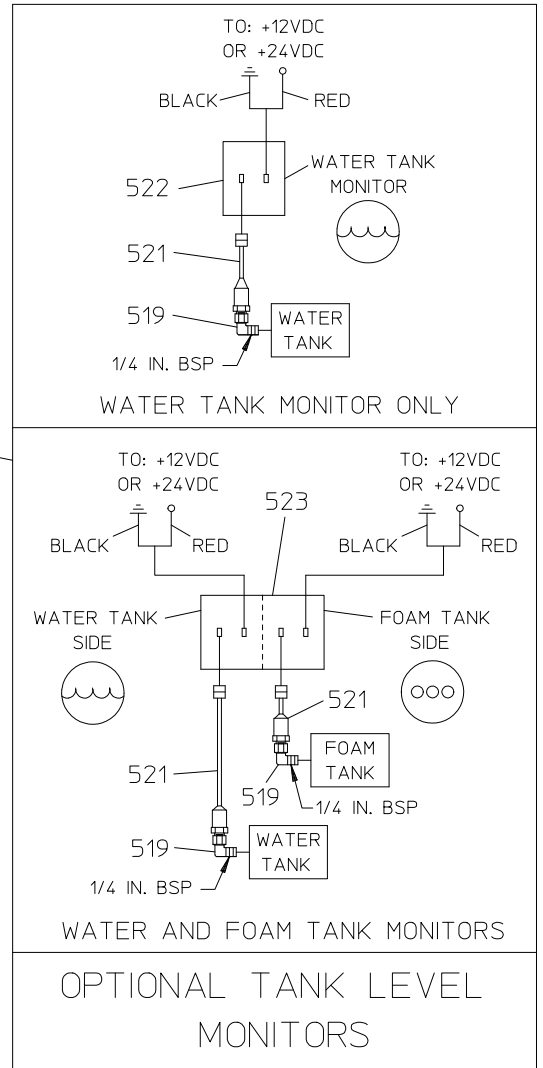
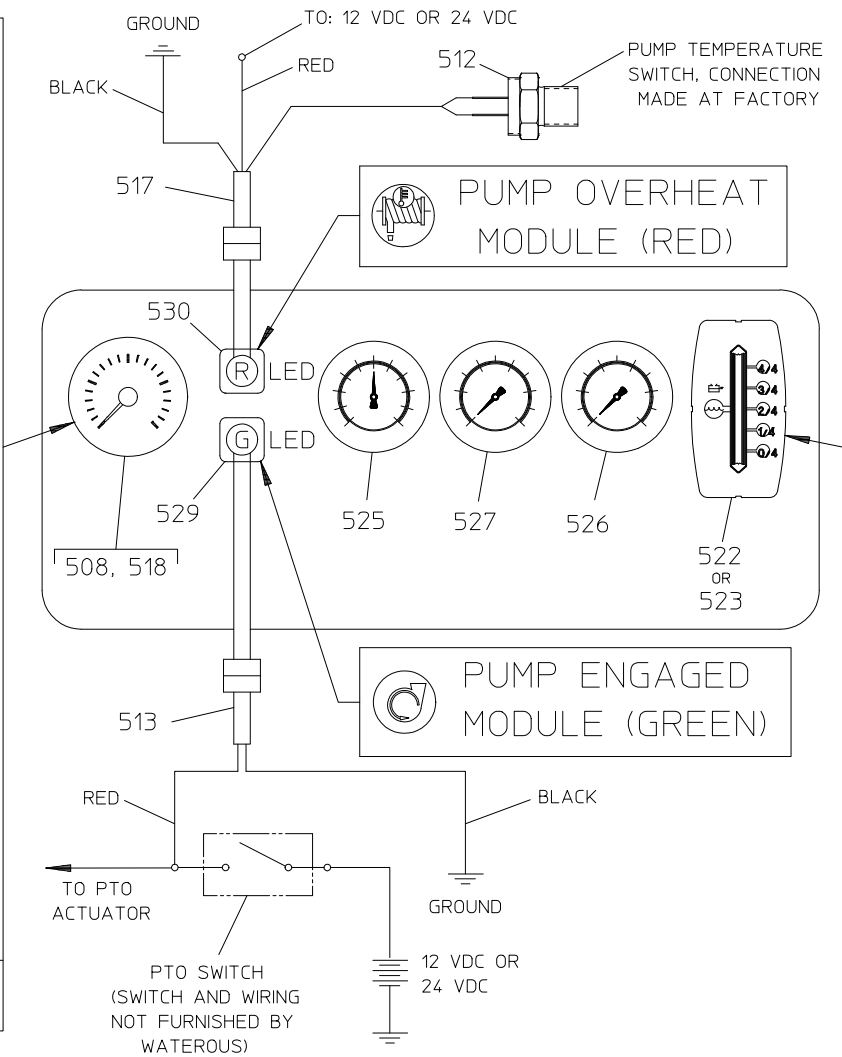
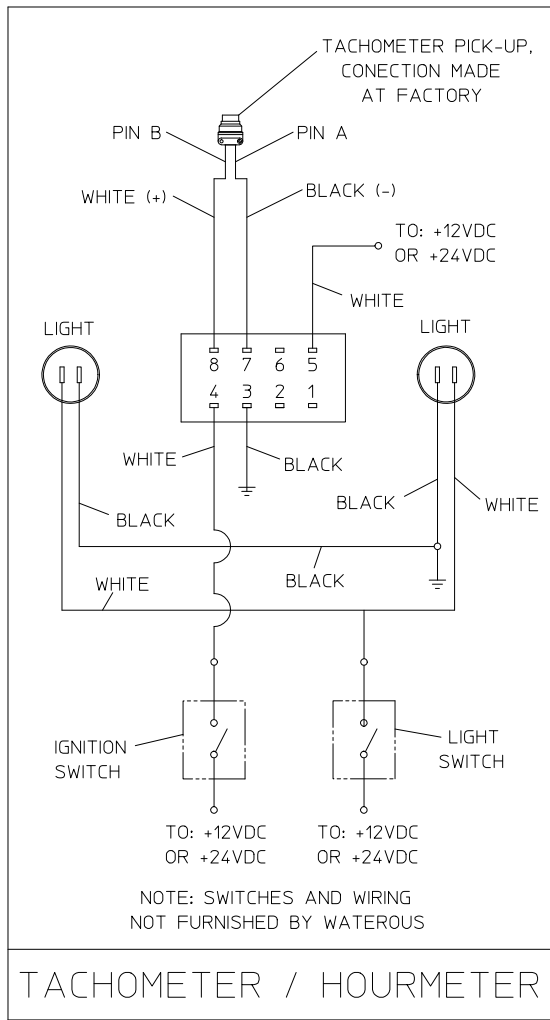

WIRING SCHEMATIC

Optional Gauges and Monitors

REF. NO.	DESCRIPTION
505	Pump Panel Gauge Package
506	Single Tank Level Monitor (Water)
507	Dual Tank Level Monitor (Water and Foam)
508	Tachometer/Hourmeter Gauge
519	Elbow, 90 Degree, 1/4 in. BSPT x 1/4 NPT
520	Tank Level Monitor Wiring Harness
521	Tank Level Monitor Sender

REF. NO.	DESCRIPTION
522	Single Tank Monitor Display Panel (Includes Mounting Hardware)
523	Dual Tank Monitor Display Panel (Includes Mounting Hardware)
524	Type E Wedge Base Light Bulb
525	Compound Gauge
526	High Pressure Gauge
527	Normal Pressure Gauge

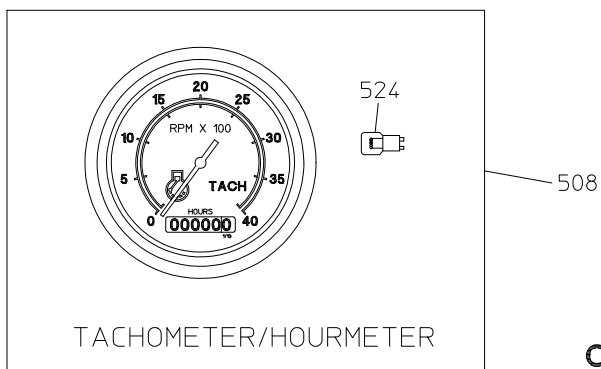
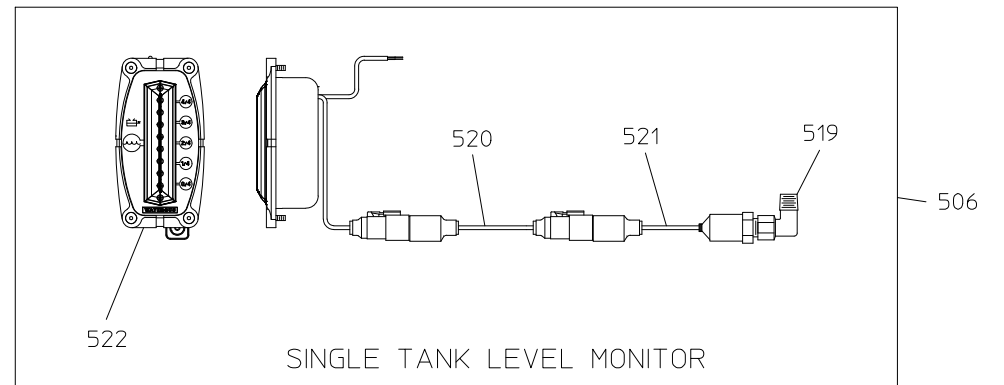
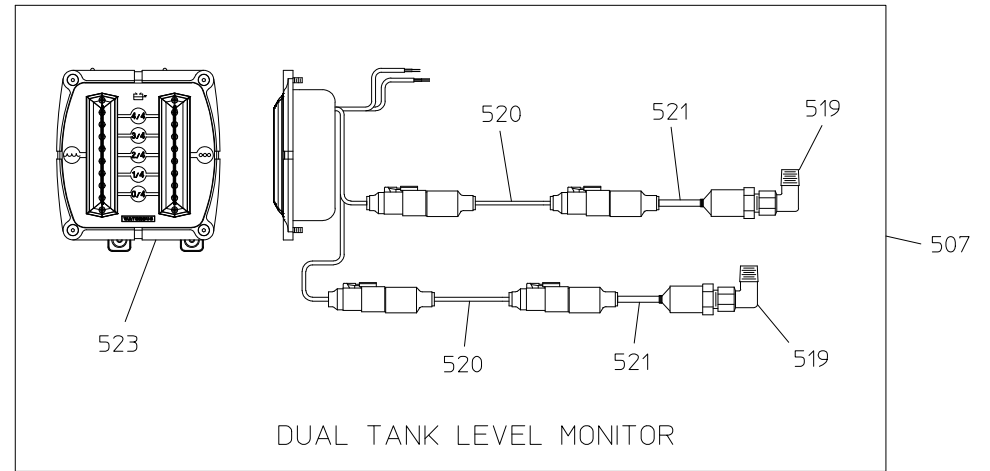
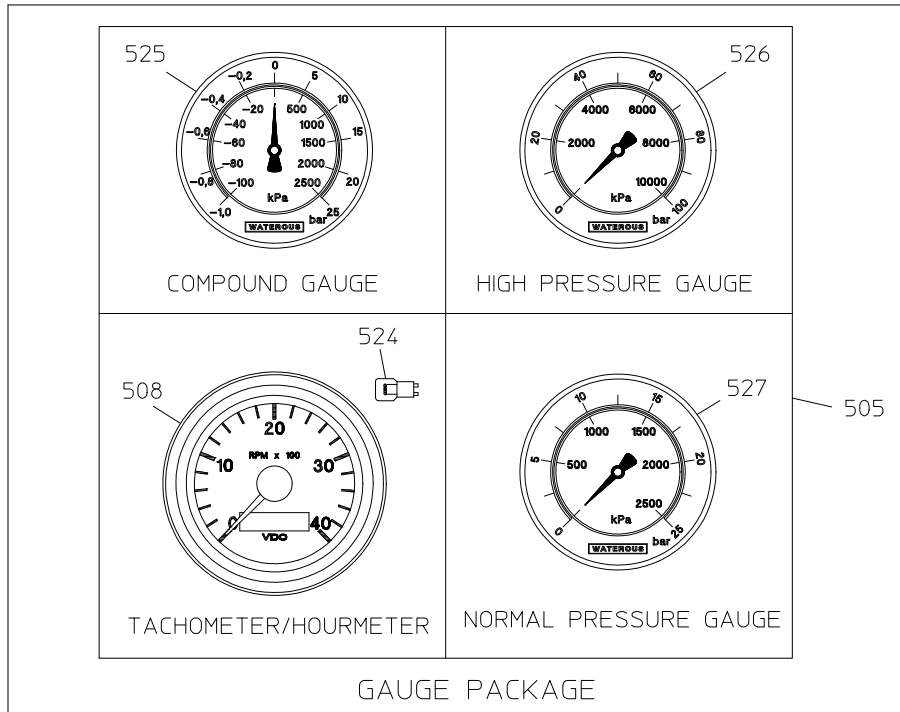

OPTIONAL GAUGES AND MONITORS