

## PTO Compressor Kit

Covers the following models:

CAFS Type			See Index on Page
Traditional	Generated		
	One-Step	Eclipse GEN 2.0	
80-P	--	--	3
140-P 200-P	150-OS	150-ECL	

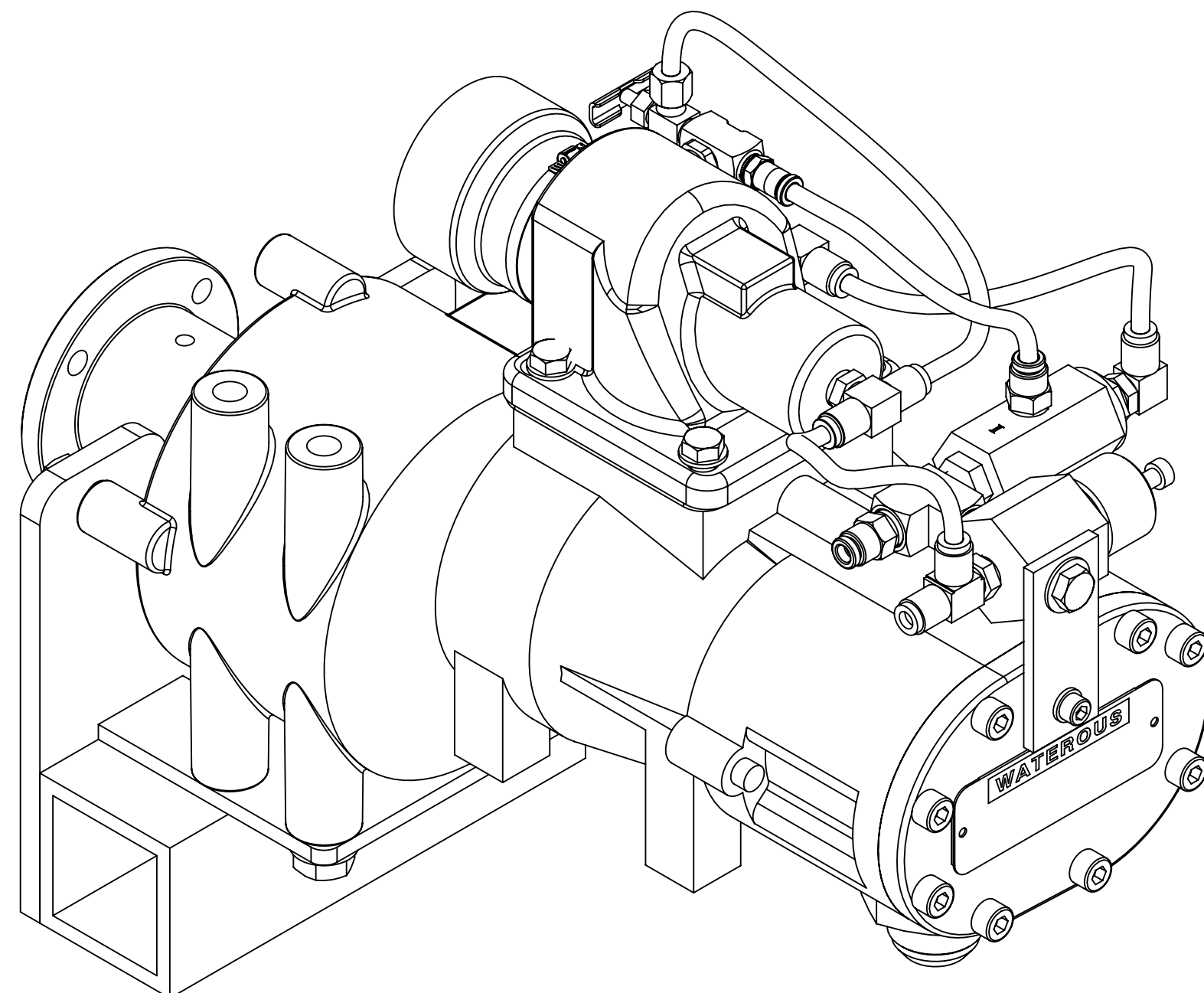

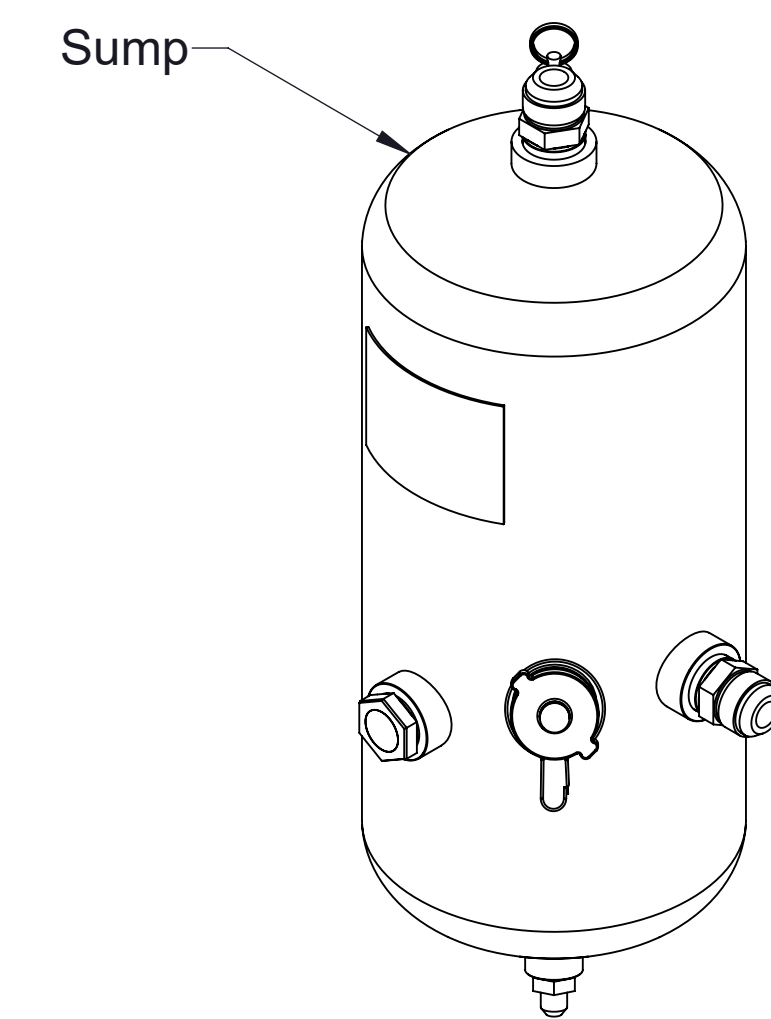
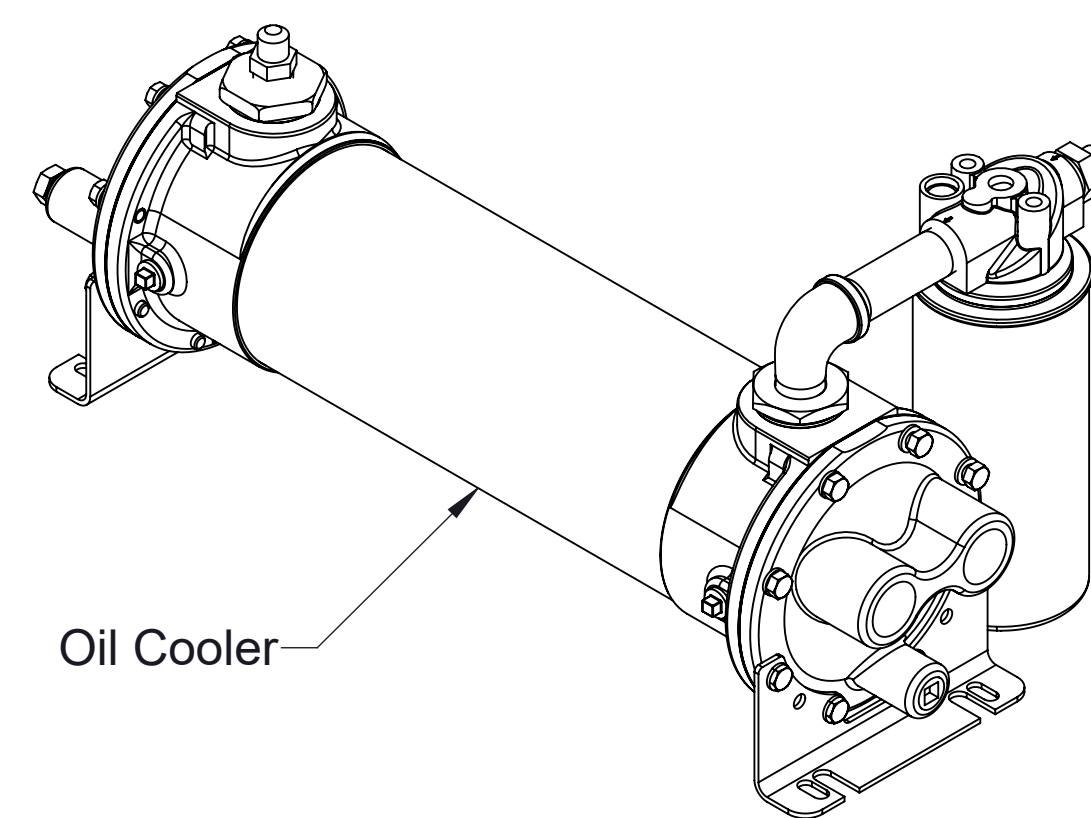
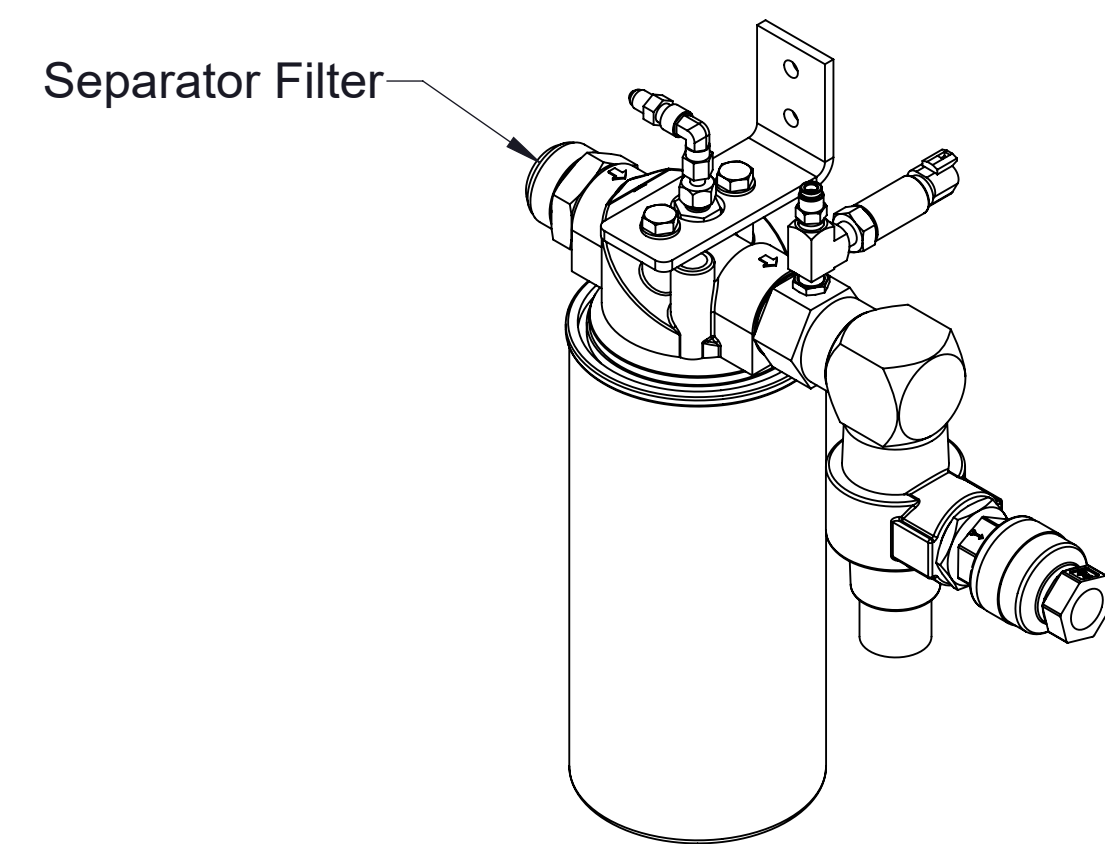
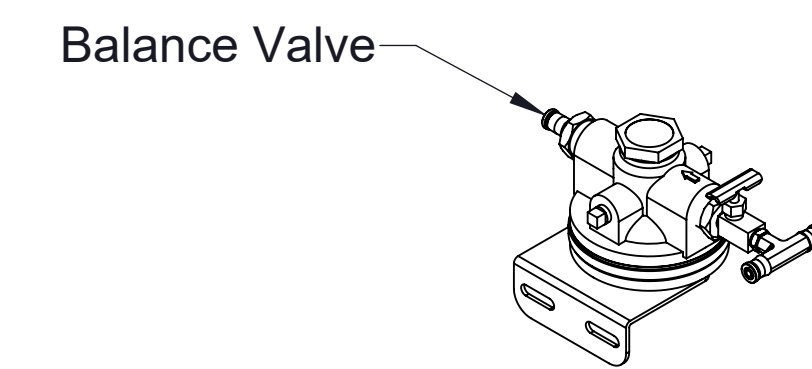
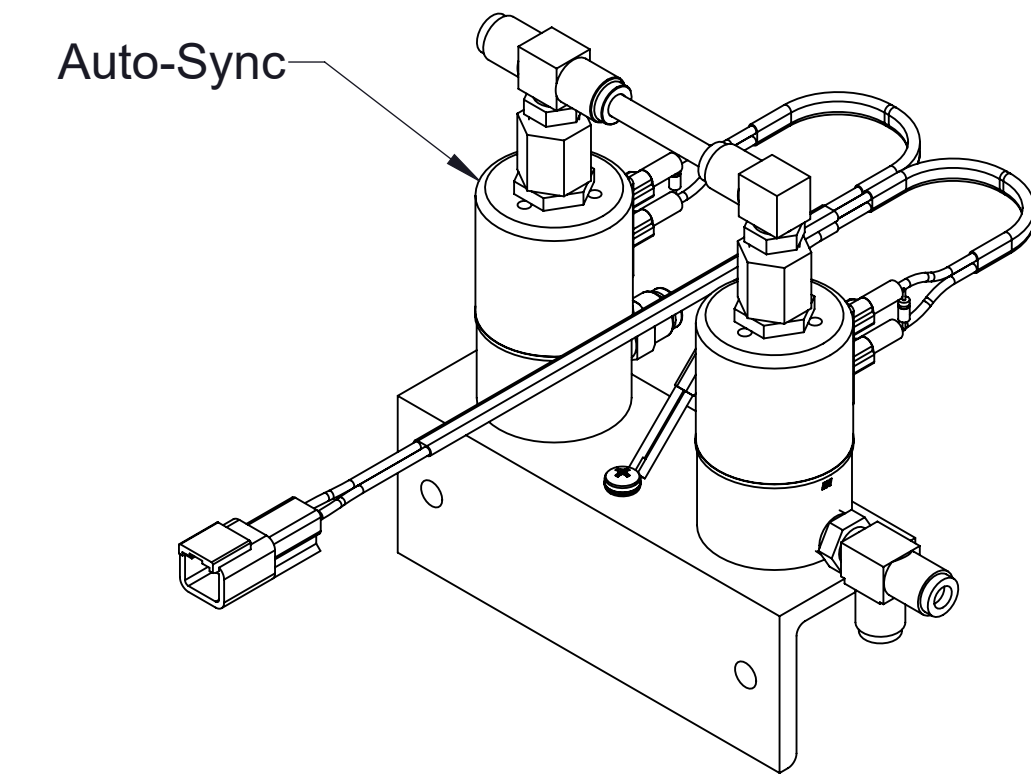
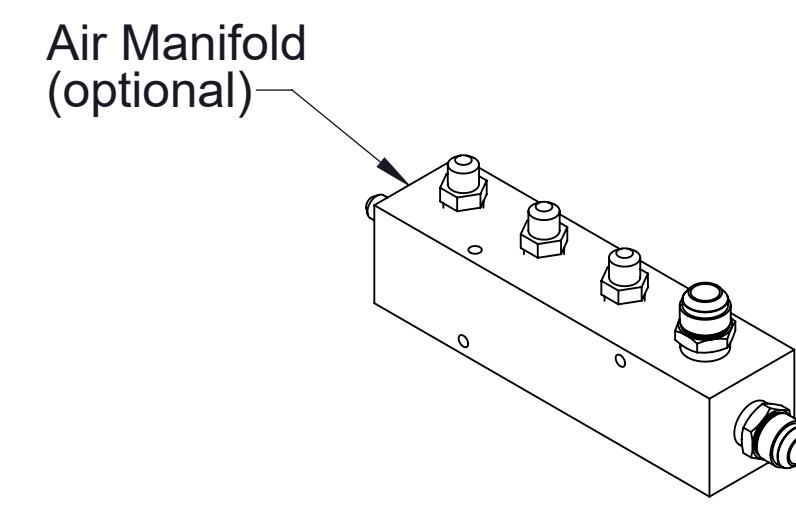
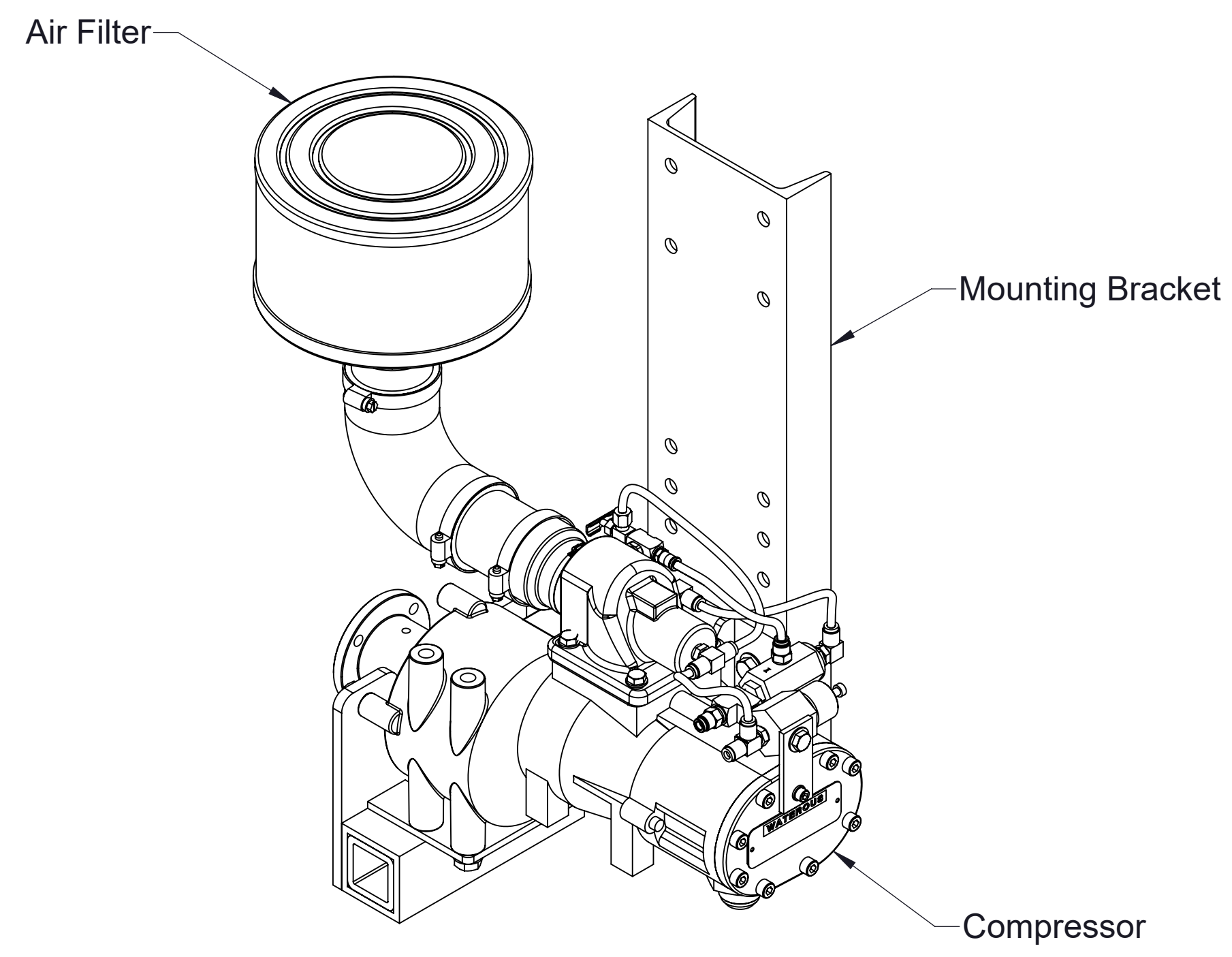

**Air Pressure Gauge Kit (optional)**

**Hose and Fitting Kit (optional)**

<b>Index:</b>						
<b>Component</b>		<b>Model</b>			<b>See Pages</b>	
		<b>Traditional CAFS</b>	<b>Generated CAFS</b>		<b>Compressor</b>	<b>Air Filter and Mounting Bracket</b>
			<b>One-Step</b>	<b>Eclipse GEN 2.0</b>		
Compressor		80-P	--	--	4	7
		140-P 200-P	150-OS	150-ECL	5 6	
Panel Components		All Models			8	
Schematic	Air	Traditional CAFS, models ending with -P			9	
		Generated CAFS, models ending with -OS, -ECL	Non-High Rise		10	
			High Rise		11	
	Hydraulic	Model 80-P			12	
		Model 140-P			13	
		Model 200-P			14	
		Model 150-OS, 150 ECL			15	
	Electrical	Traditional CAFS, models ending with -P			16	
		Generated CAFS, models ending with -OS, -ECL			See Foam Generator Service Parts List	
Auto-Sync		See Auto-Sync Service Parts List Traditional CAFS, all models ending with -P Generated CAFS with High Rise options only, models ending with -OS, -ECL				
Balance Valve		See Balance Valve Service Parts List, Traditional CAFS, all models ending with -P				
Oil Cooler		See Oil Cooler Service Parts List (all models)				
Separator Filter		See Separator Service Parts List (all models)				
Sump		See Sump Service Parts List (all models)				
Air Manifold		Optional from Waterous, may have been furnished by OEM. See the following Service Parts Lists: Air Manifolds ICS Valves Air Discharge Kits Air Pressure Gauge Hoses and Fittings				
CAFS Discharge						
Air Pressure Gauge						
Hoses and Fittings						



Ref No.	Description
2	Plate-Serial
78	Tape, 1 in Wide
200	Compressor Subassembly (includes 201-238 and 900)
201	Inlet-Air, 90°
202	Bushing-Reducing, 1/4 MNPT x 1/8 FNPT
203	Tee-Branch, 1/8 MNPT x 1/8 FNPT x 1/8 FNPT
204	Valve-Trim, 1/8 MNPT x 1/4 AB
206	Elbow-90°, 1/4 MNPT x 1/4 AB
207	Tee-Branch, 1/4 MNPT x 1/4 AB x 1/4 AB
208	Clamp
209	Reducer-Rubber, 2.50 x 2.0 in
210	Connector-Straight, 1/8 MNPT x 1/4 AB
213	Adapter-Straight, 4 MJIC x 10 mm
215	Adapter-Straight, 6 MJIC x 16 mm
219	Flange-Companion
220	Bracket-Mounting
221	Gasket-Air Inlet
226	Adapter-Straight, 1-1/4 BSP x 16 MJIC
227	Compressor-Air End
231	Compressor Replacement Kit
233	Screw-Set, Cup Point, Hex Soc, 5/16-18 x 1/2 in
234	Screw-Hex Hd, M8-1.25 x 25 mm
235	Screw-Hex Hd, M12-1.75 x 30 mm
237	Washer-Flat, 8 mm
238	Washer-Flat, 12 mm
245	Sleeve-Internal Support
247	Shaft Seal Repair Kit
251	Screw-Soc Hd, M6-1 x 25 mm
252	Washer-Flat, 6 mm
900	PMC Subassembly

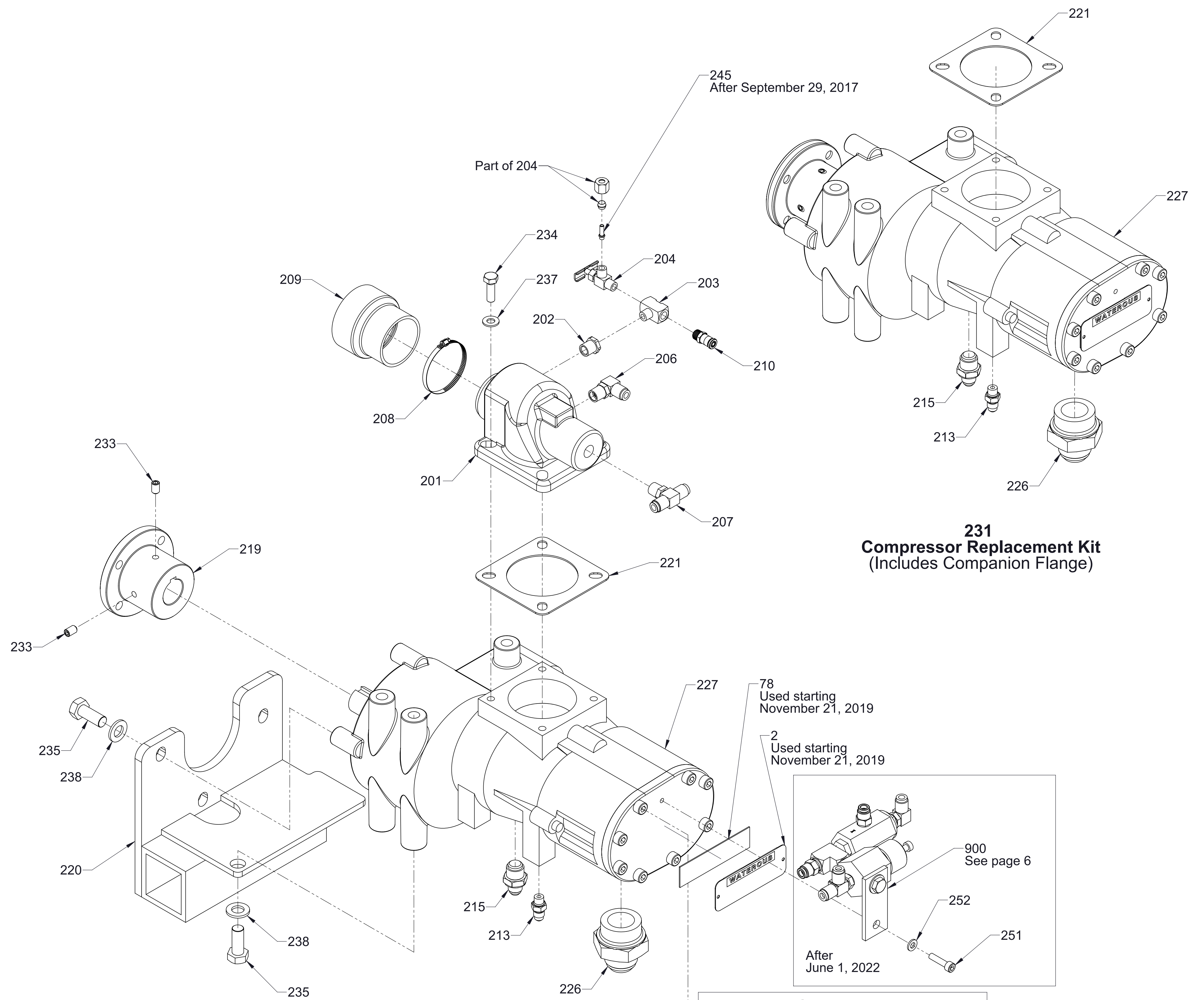

**200**  
Compressor Subassembly  
(includes 201-238 and 900)

**247**  
Shaft Seal Repair Kit

**231**  
Compressor Replacement Kit  
(Includes Companion Flange)

**Compressor-Model 80-P**

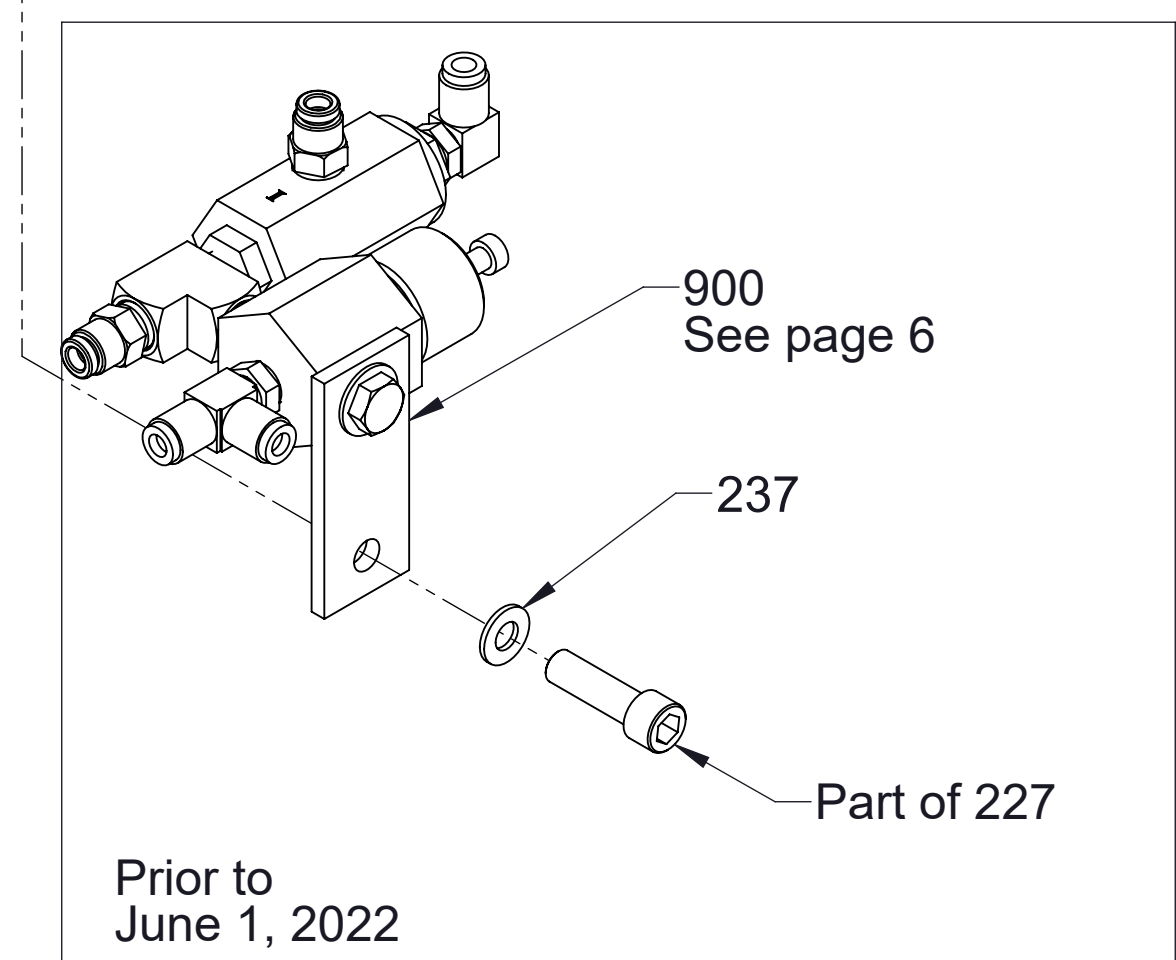
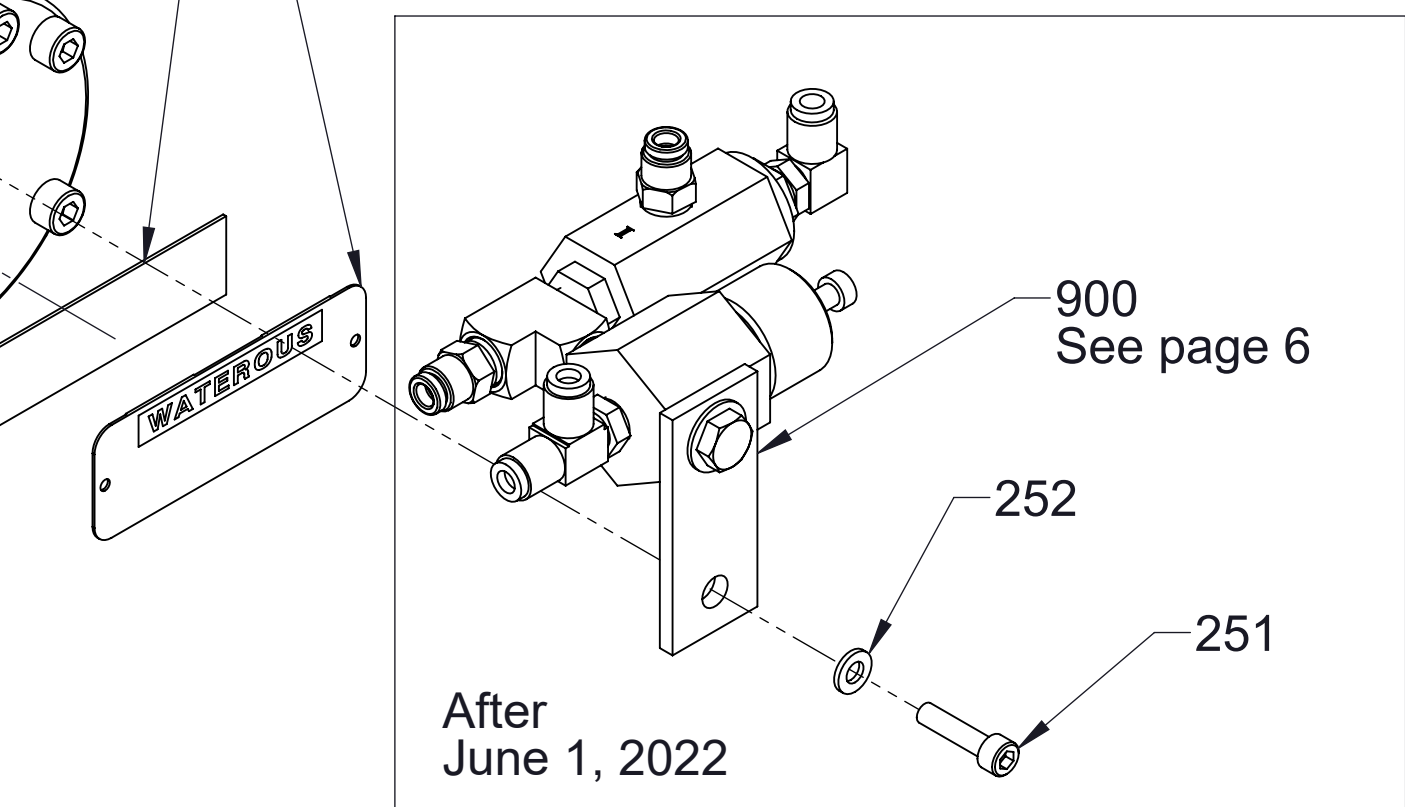



Ref No.	Description
1	Adapter-Straight, 24 MJIC x 1-1/2 MNPT
2	Plate-Serial
9	Flange-Outlet (CF75)
10	Gasket-Outlet Flange
24	Screw-Hex Hd, M16-2 x 30 mm
78	Tape, 1 in Wide
200	Compressor Subassembly (Includes 201-236 and 900)
201	Inlet-Air, 90°
202	Bushing-Reducing, 1/4 MNPT x 1/8 FNPT
203	Tee-Branch, 1/8 MNPT x 1/8 FNPT x 1/8 FNPT
204	Valve-Trim, 1/8 MNPT x 1/4 AB
205	Elbow-90°, 1/8 MNPT x 1/4 AB
206	Elbow-90°, 1/4 MNPT x 1/4 AB
207	Tee-Branch, 1/4 MNPT x 1/4 AB x 1/4 AB
214	Adapter-Straight, 4 MJIC X 12 MM
217	Hose Assembly, Oil Injection
218	Fitting-Oil Return Tee
219	Flange-Companion
220	Bracket-Mounting
223	Fitting-Oil Injection
227	Compressor-Air End
231	Compressor Replacement Kit
232	O-Ring, 3-7/8 X 4-1/4 in
233	Screw-Set, Cup Point, Hex Soc, 5/16-18 x 1/2 in
235	Screw-Hex Hd, M16-2 x 30 mm
236	Screw-Soc Hd, M16-2 x 30 mm
237	Washer-Flat, 8 mm
238	Washer-Flat, 16 mm
245	Sleeve-Internal Support
247	Shaft Seal Repair Kit
248	Shaft Seal Installation Tool
249	Compressor Outer Bearing
250	Compressor Inner Bearing
253	Washer-Spring, Compressor (Repairs)
900	PMC Subassembly

**200**  
Compressor Subassembly  
(includes 201-236 and 900)

**247**  
Shaft Seal Repair Kit

**248**  
Shaft Seal Installation tool

**249**  
Compressor Outer Bearing

**250**  
Compressor Inner Bearing

**253**  
Compressor Spring Washers  
(5 washers required for repairs only)

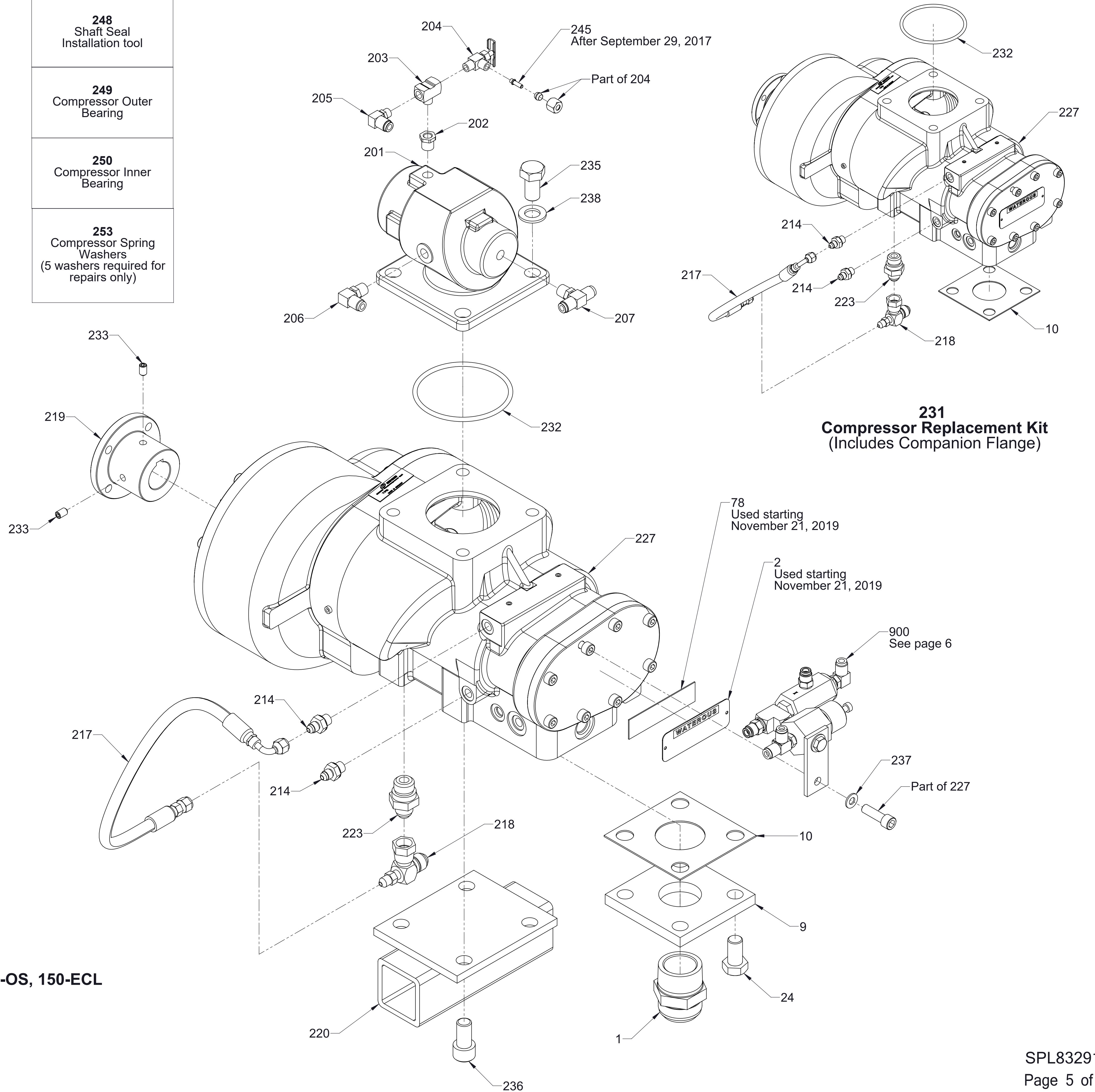

**Compressor-Models 140-P, 200-P, 150-OS, 150-ECL**

Ref No.	Description
900	PMC Subassembly (Includes 901-914)
901	Pressure Regulator
902	Valve-Blowdown
903	Bracket
904	Adapter-Straight, 1/4 MNPT x 1/4 AB
905	Elbow-90°, 1/4 MNPT x 1/4 AB
906	Tee-Branch, 1/4 MNPT x 1/4 MNPT x 1/4 FNPT
907	Tee-Branch, 1/4 AB x 1/4 MNPT x 1/4 AB
908	Washer-Plain, 3/8 in
909	Screw-Hex Hd, 3/8-16 x 1/2 in
910	Valve-Solenoid
911	Nipple-Pipe, 1/4 NPT x 7/8 in
912	Tee-Pipe, 1/4 NPT
914	Tee-Street, 1/4 NPT

906  
Used prior to  
June 19, 2014

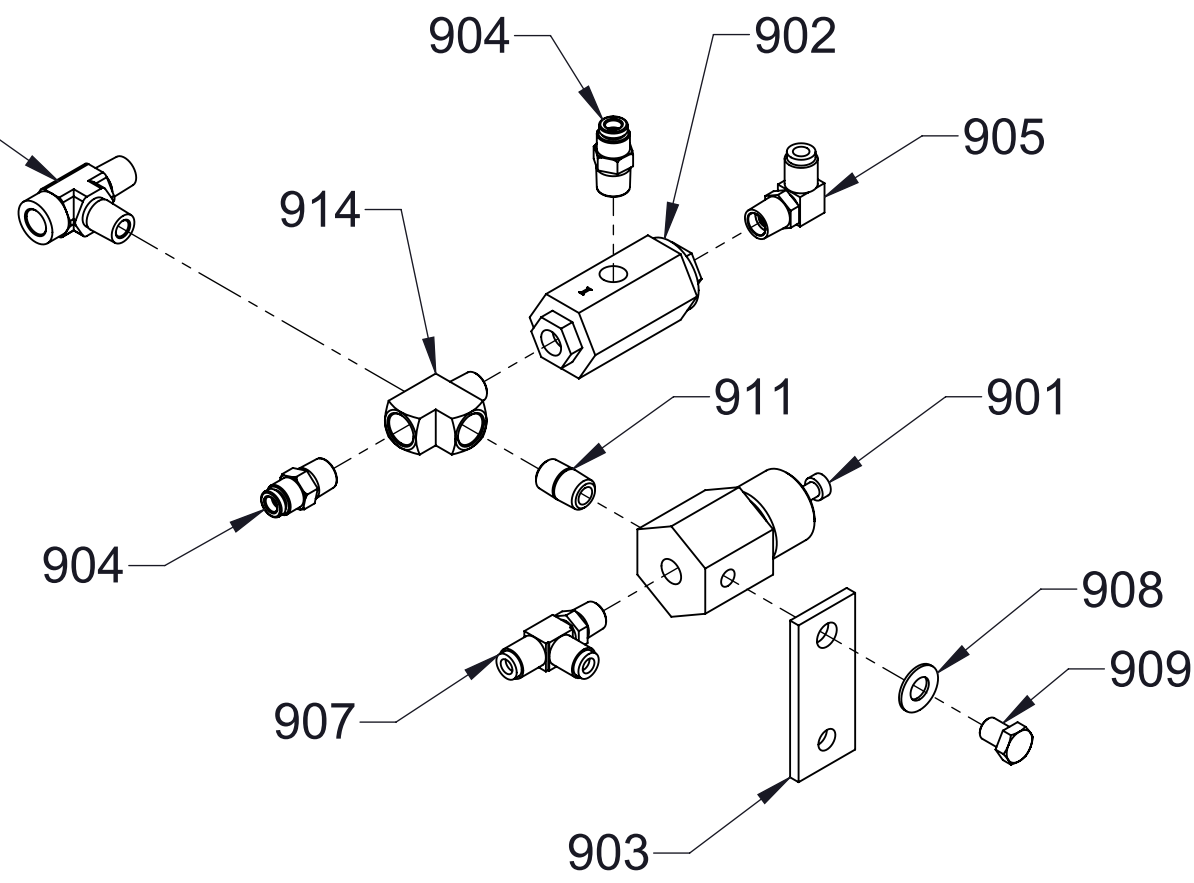

**Traditional CAFS**  
Models 80-P, 140-P, 200-P

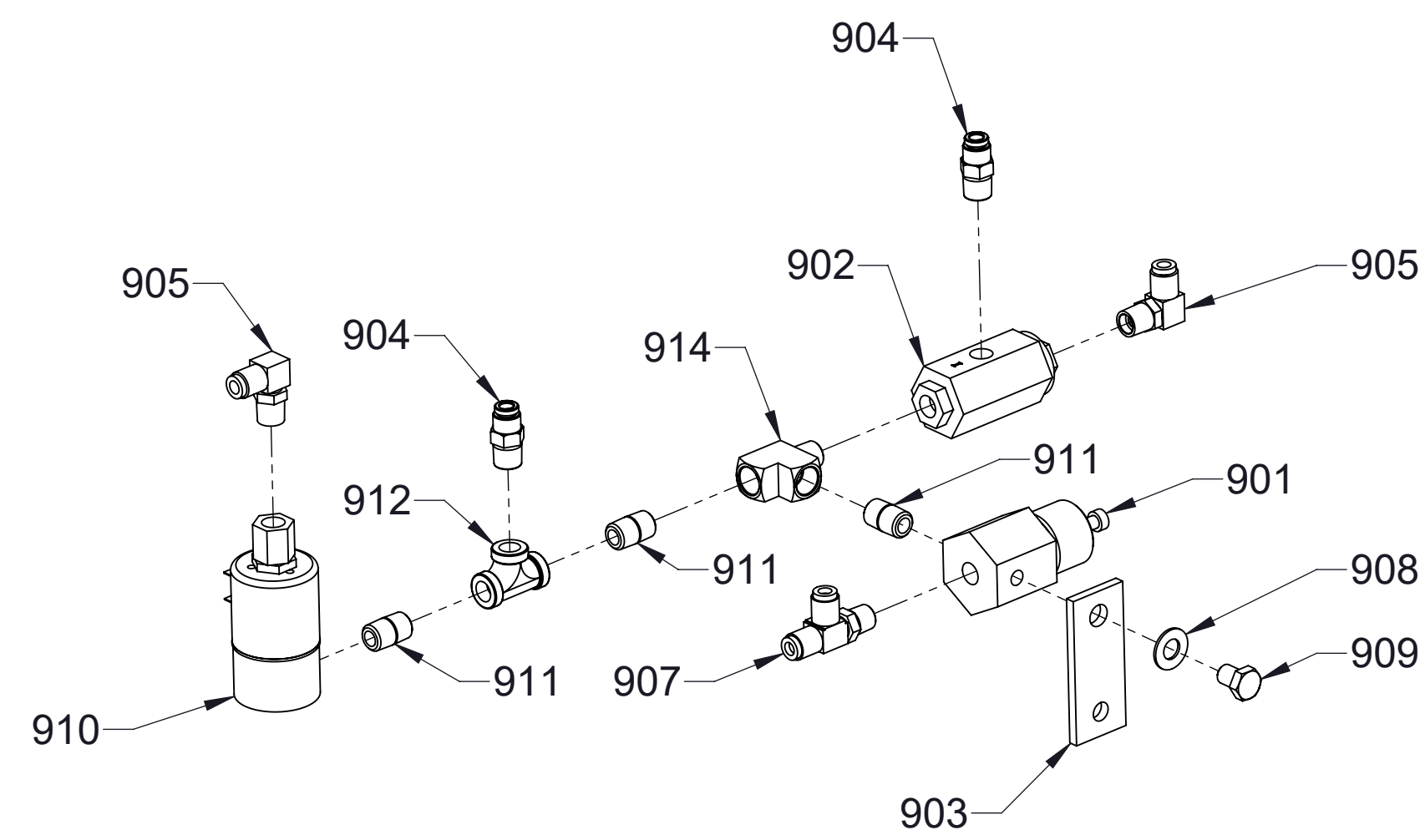

**Generated CAFS  
without High Rise Option**  
Models 150-OS, 150-ECL

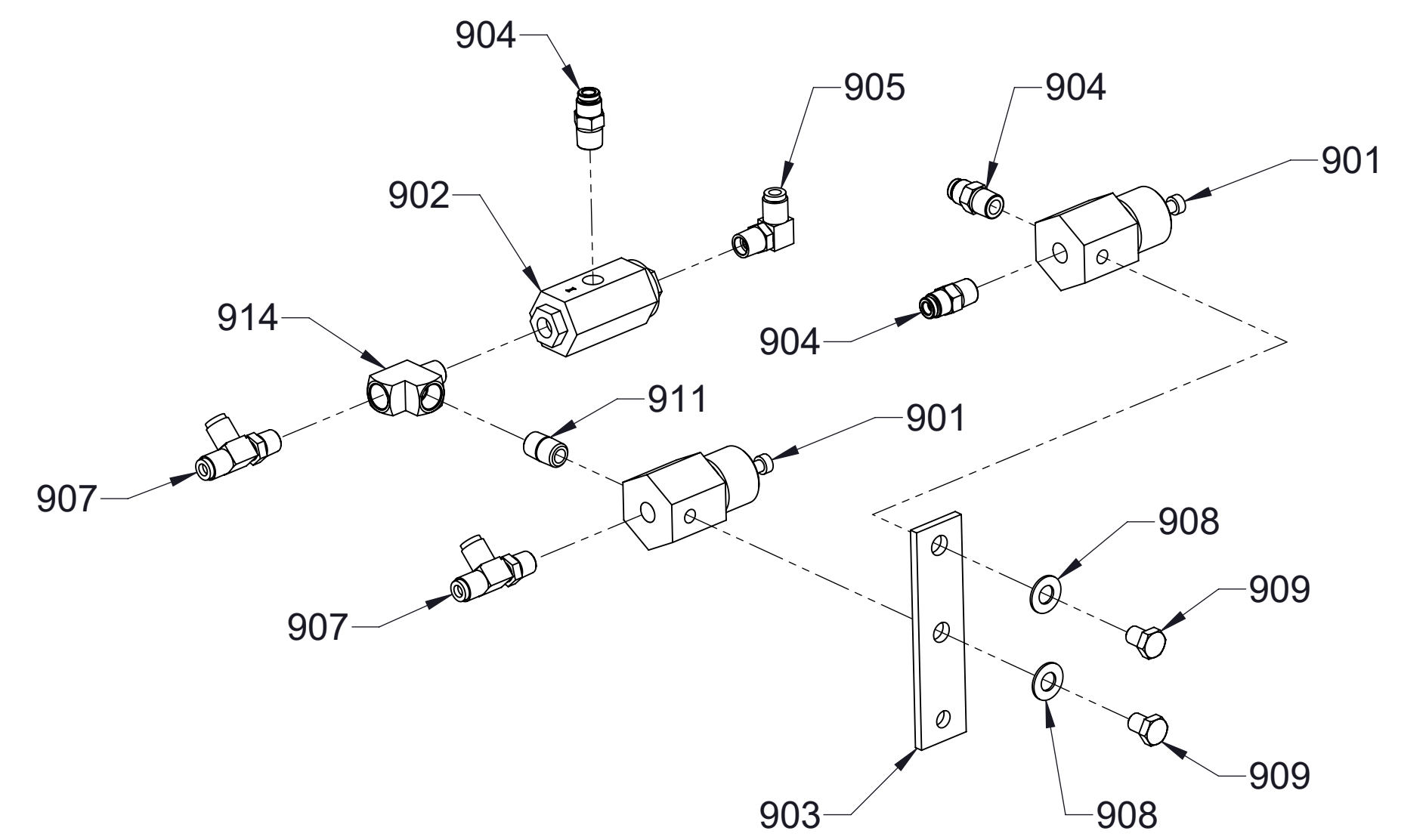

**Generated CAFS  
with High Rise Option**  
Models 150-OS, 150-ECL

**Compressor Subassembly PMC Variations**



Ref No.	Description
40	Filter-Air, 2 1/2 in
41	Air Inlet Tube, 2-1/2 x 48 in (Cut to suit application)
42	Clamp, 2-5/16 to 3-1/4 in
43	Clamp-T-Bolt, 2-1/2 in
44	Elbow-90°, 2-1/2 in
200	Compressor Subassembly

Ref No.	Description
53	Channel-Support
54	Tube
55	Screw-Hex Hd, 7/16-14 x 1-1/2 in
56	Washer-Plain, 7/16 in
57	Nut-Hex, Nylok, 7/16-14
220	Bracket-Mounting

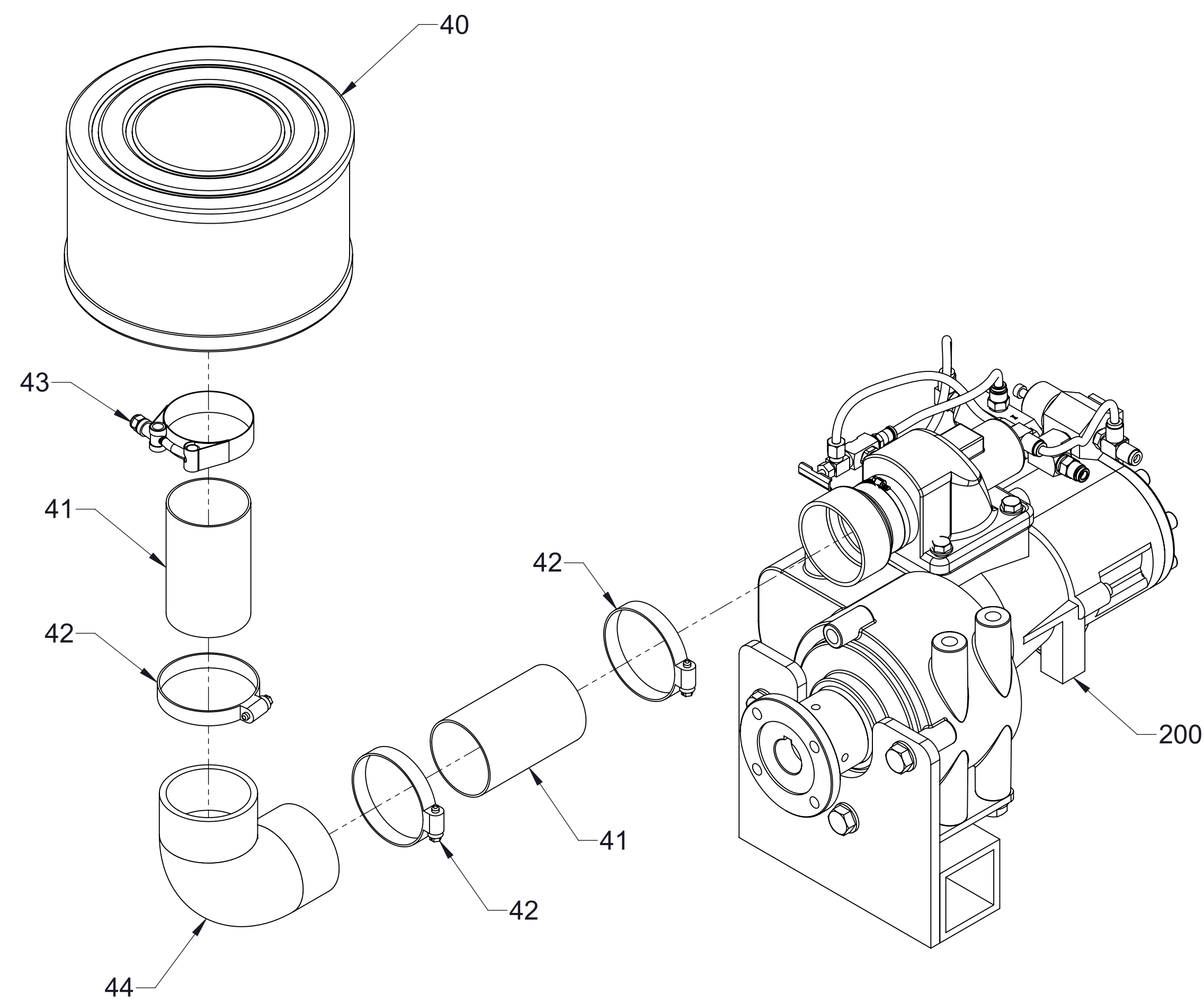

### Air Filter

Note: Based on installation, configuration may vary from diagram.

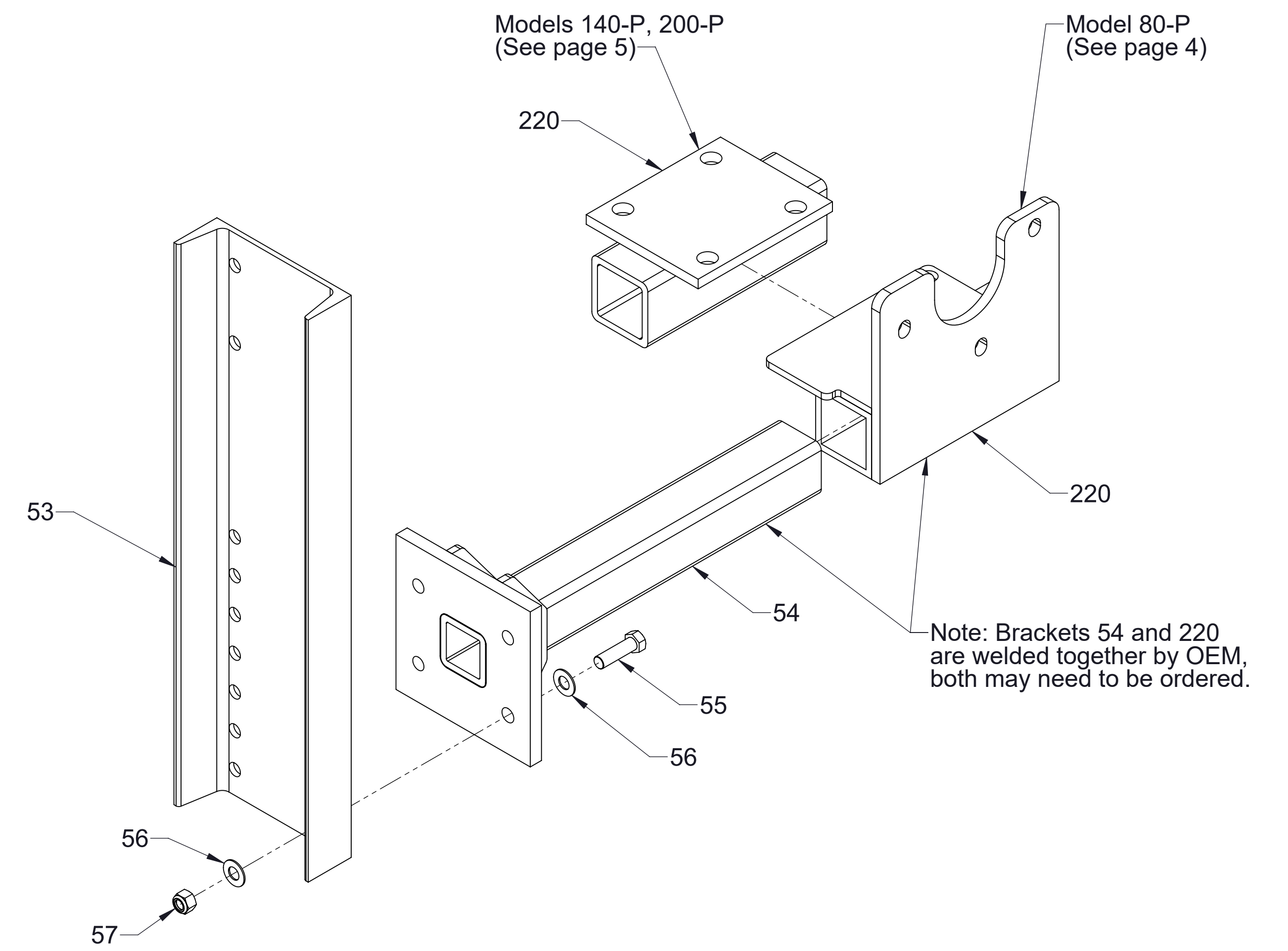

### Mounting Bracket

Note: Brackets 54 and 220 are welded together by OEM, both may need to be ordered.

Ref No.	Description
2	Plate-Serial
45	Dual Scale Oil Temperature Gauge
46	Oil Temp Gauge to 24V Conversion Kit
60	Compressed Air Warning Plate
61	Hose Length Plate
325	Plate-Electric Auto-Sync
326	Harness-Switch, Electric Auto-Sync

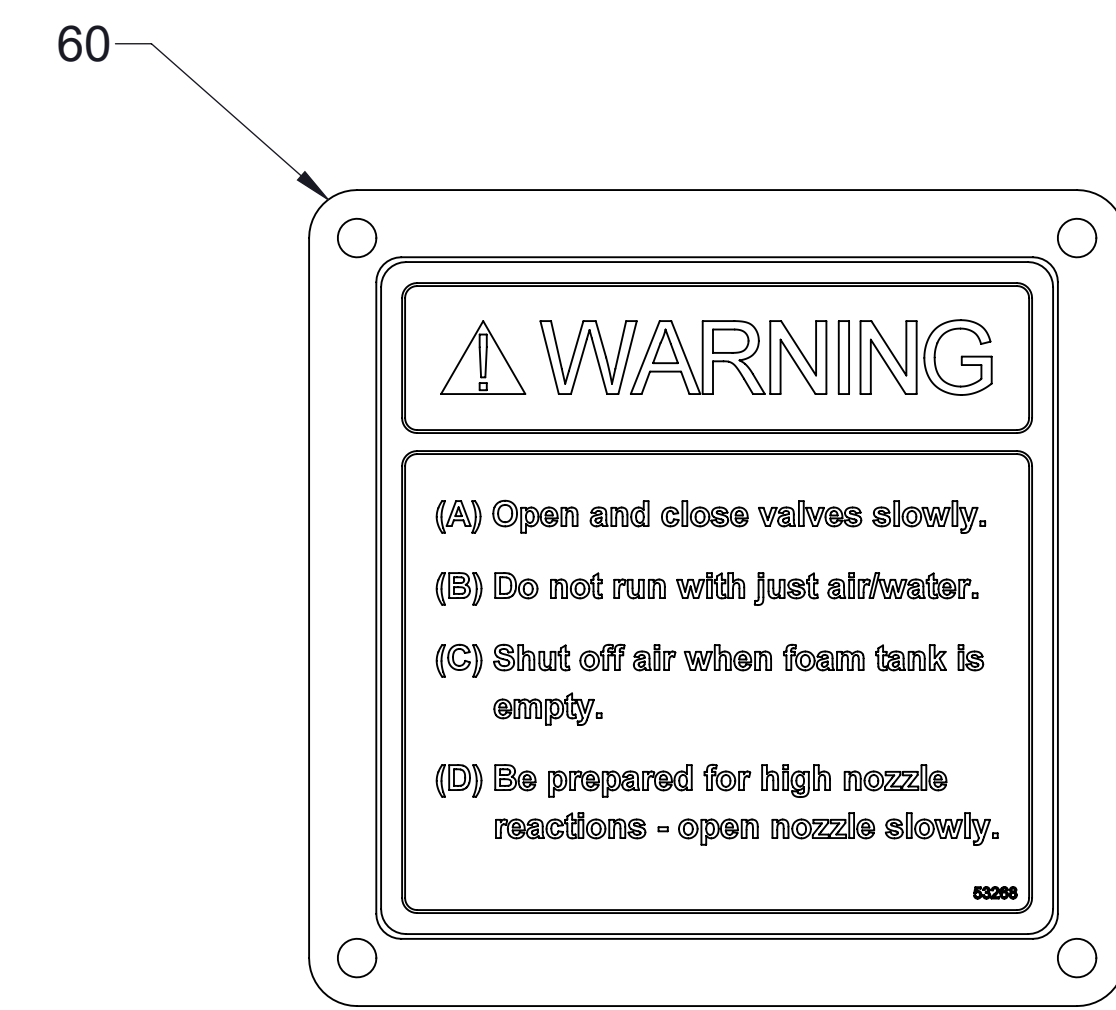
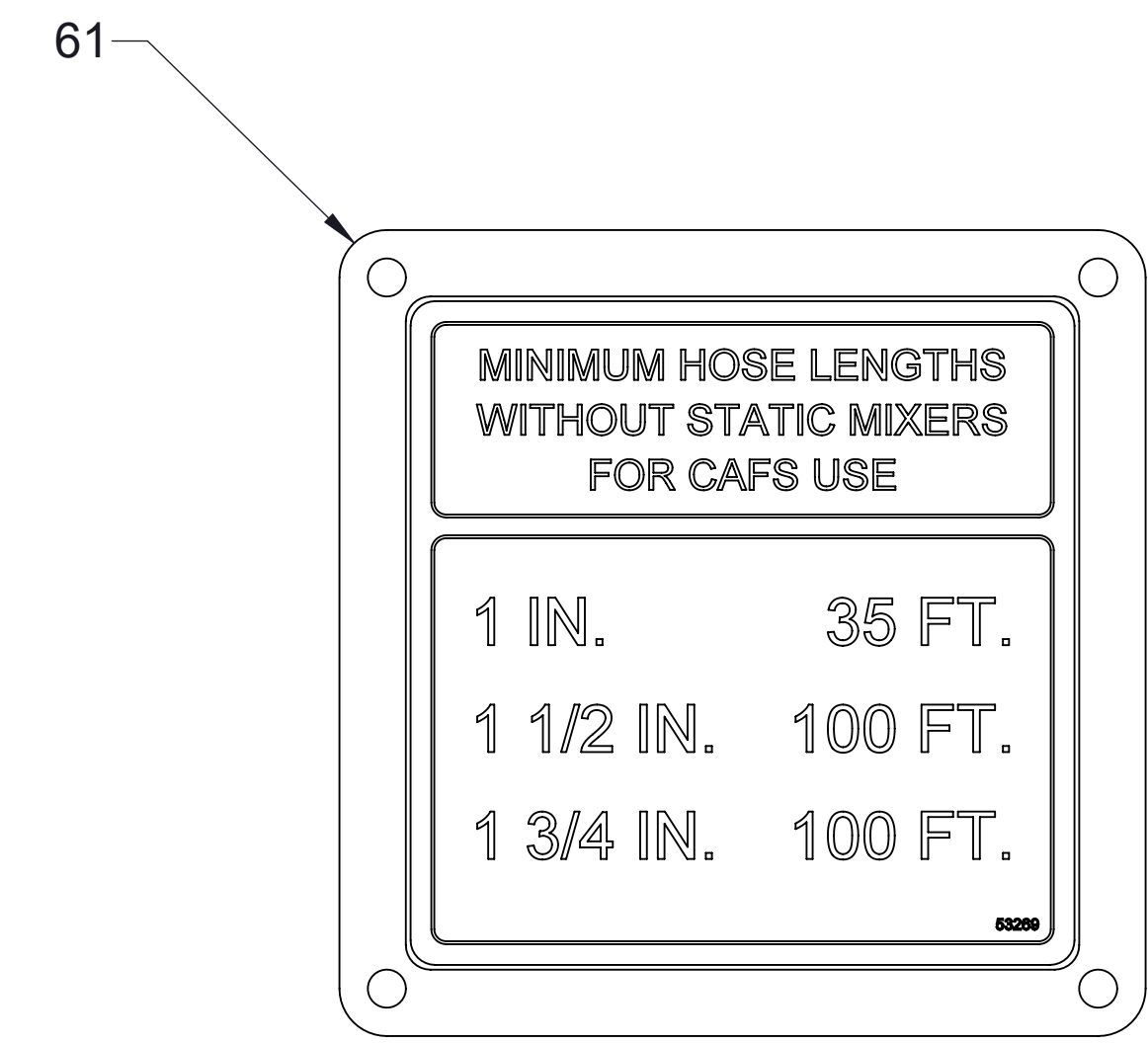
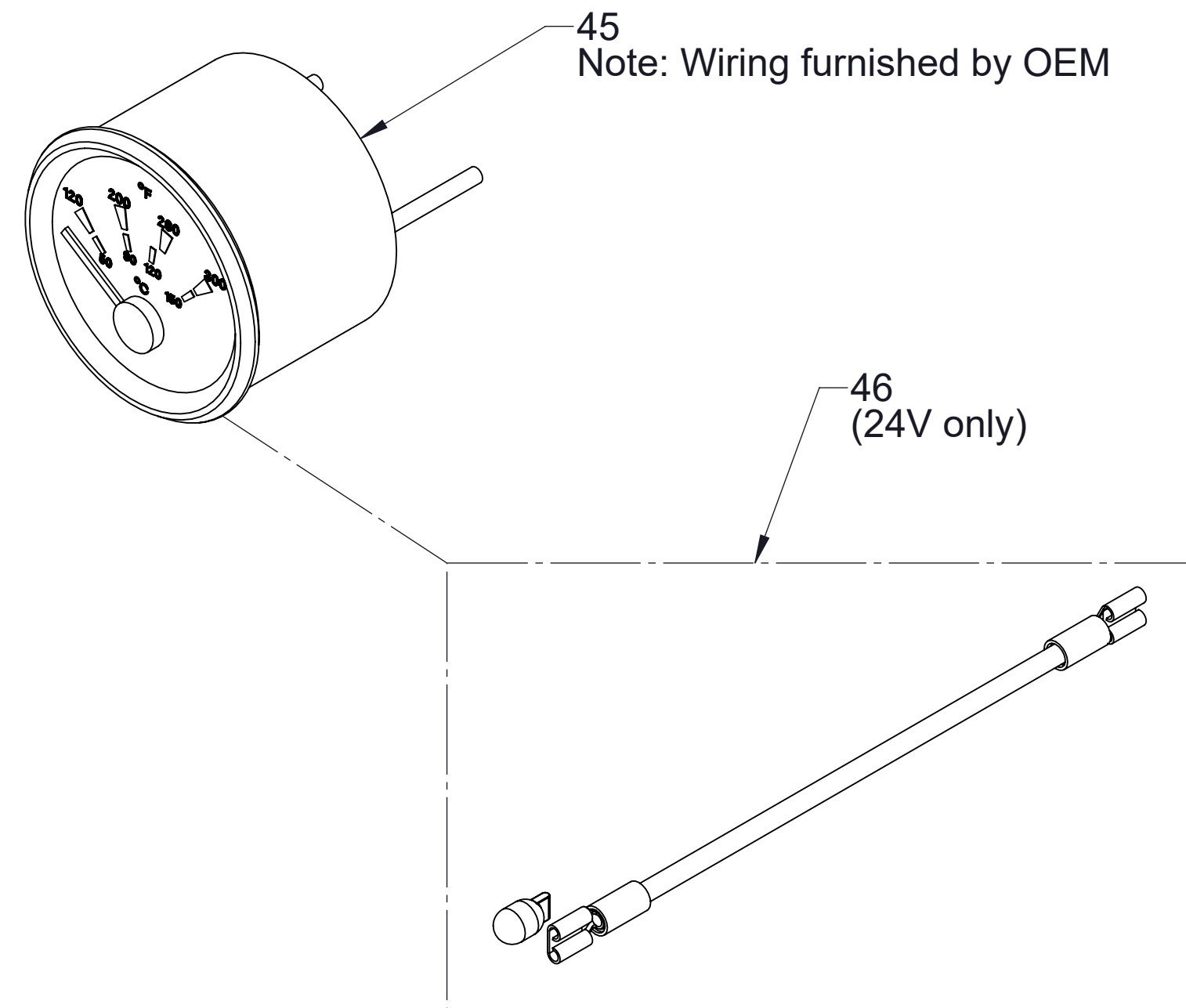
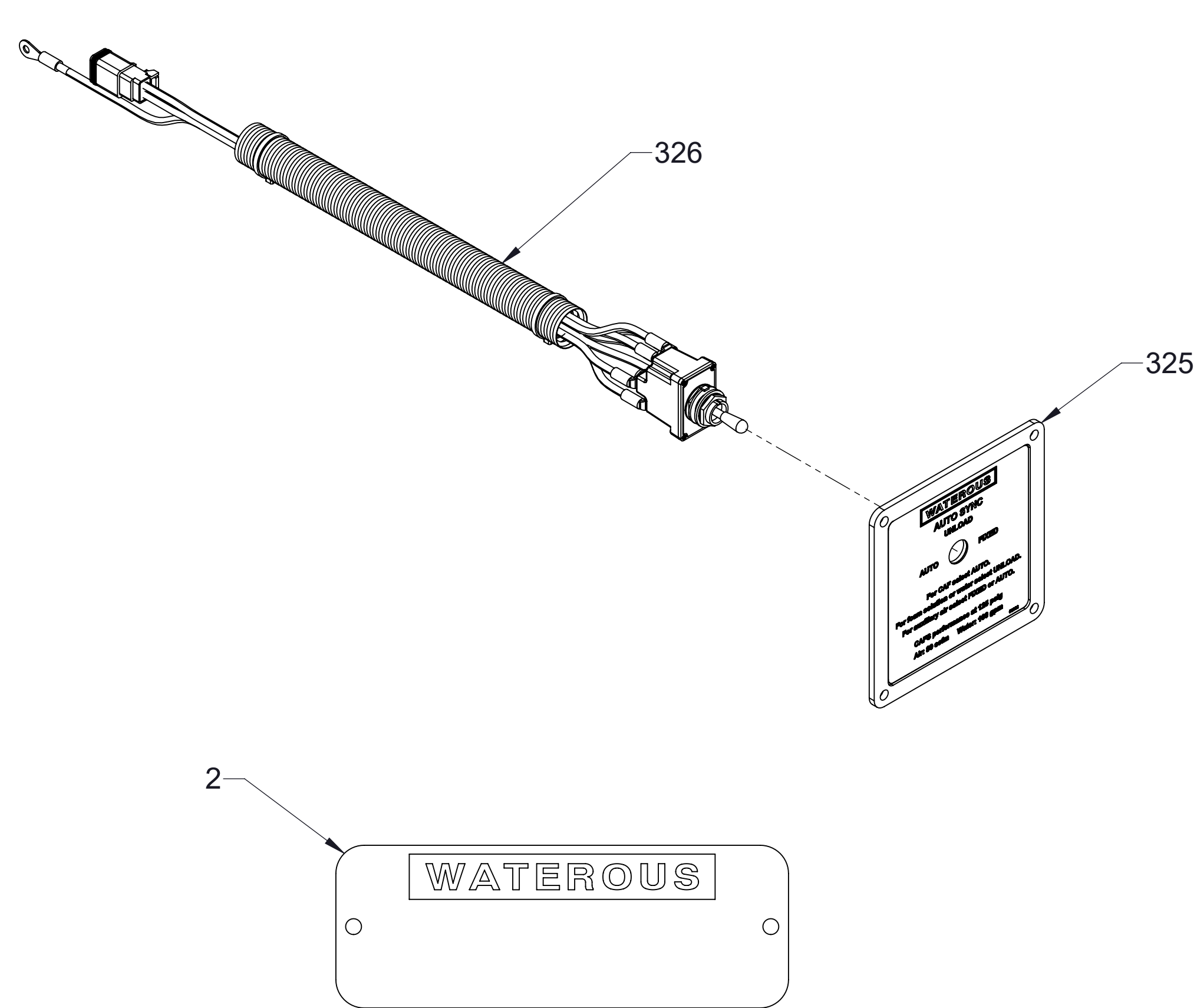

**Traditional CAFS**

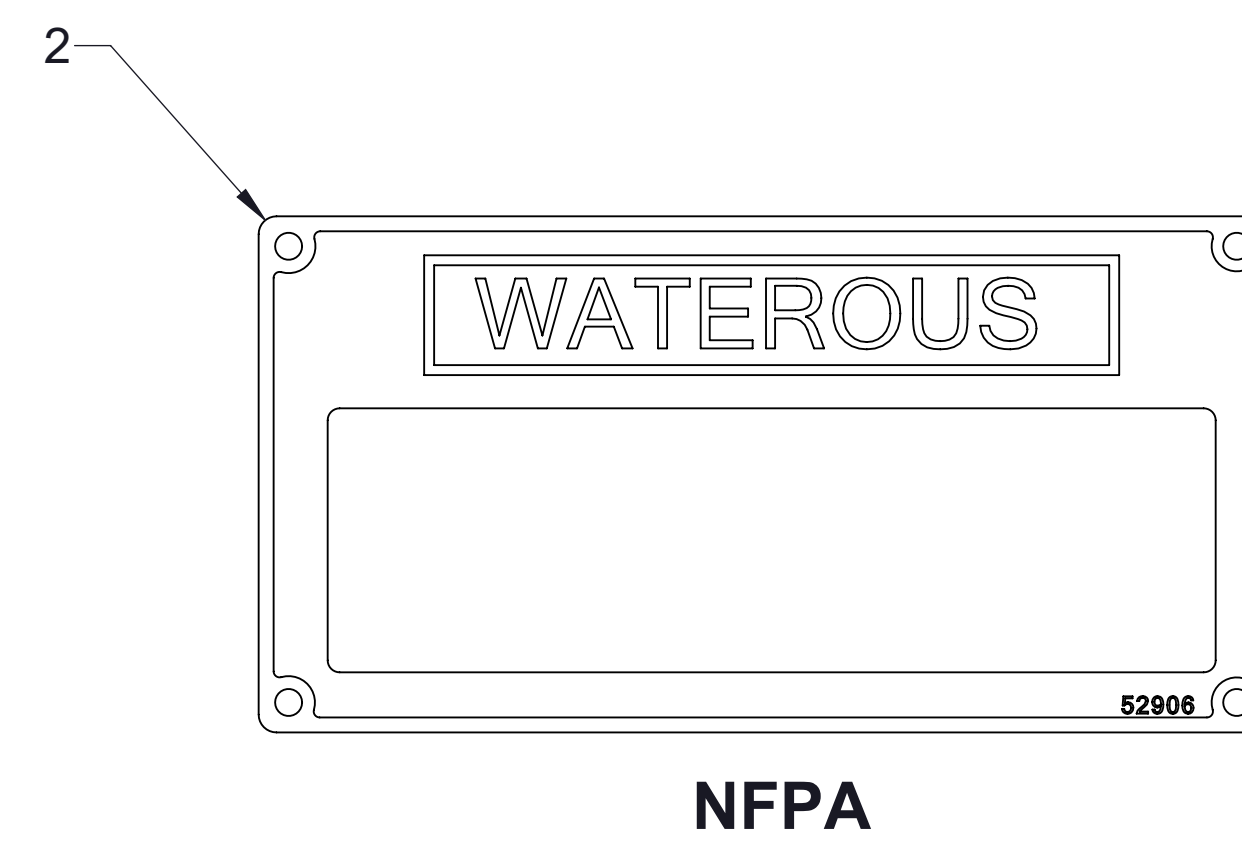
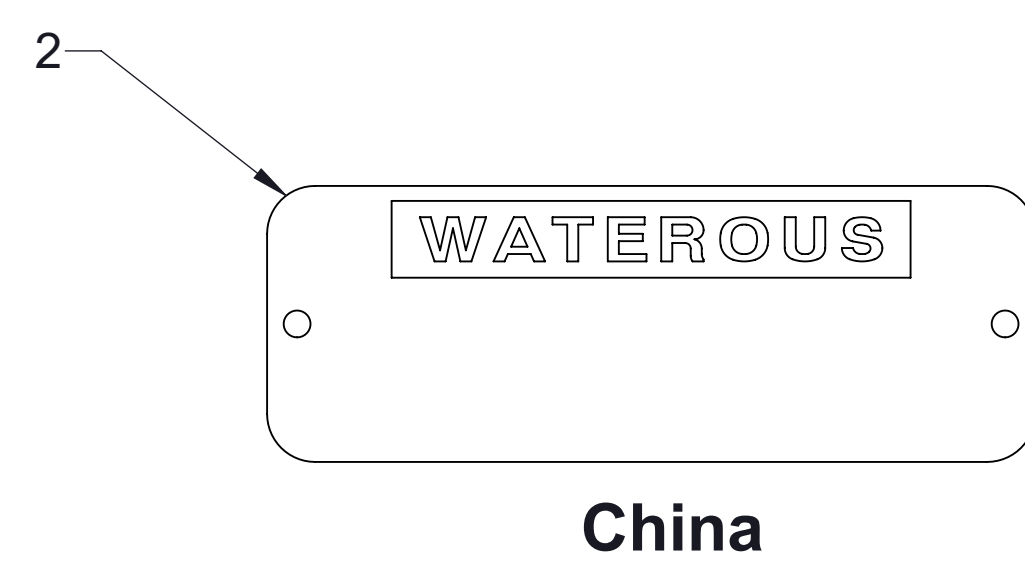

**Generated CAFS**

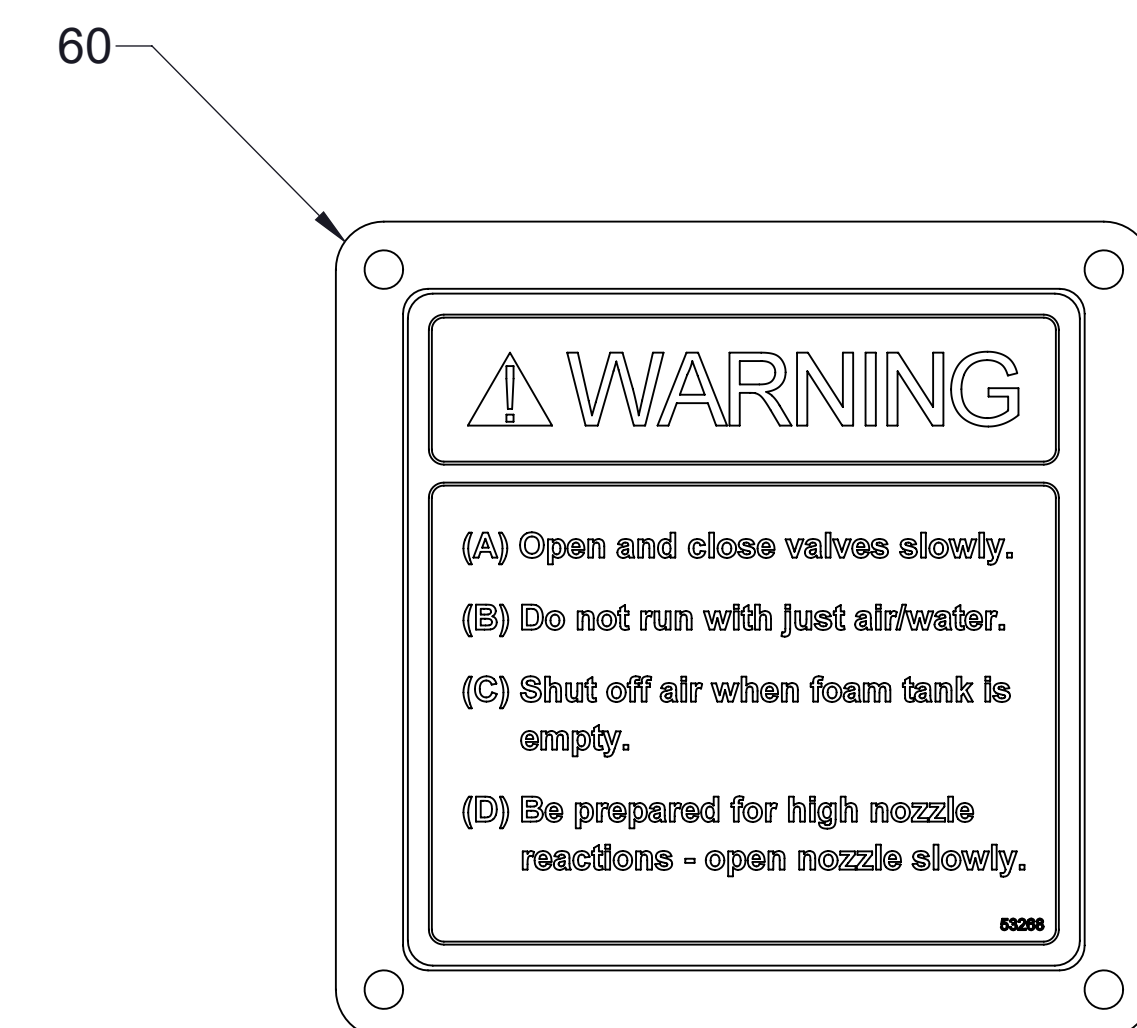

**Panel Components**



Ref No.	Description
63	Black Air Brake Tube, 1/4 in x 180 in Long (cut to suit application)
64	Red Air Brake Tube, 1/4 in x 120 in Long (cut to suit application)
65	Yellow Air Brake Tube, 1/4 in x 120 in Long (cut to suit application)
201	Inlet-Air, 90°
228	Red Air Brake Tube, 1/4 in x 24 in Long (cut to suit application)
229	Blue Air Brake Tube, 1/4 in x 24 in Long (cut to suit application)
230	Green Air Brake Tube, 1/4 in x 24 in Long (cut to suit application)
300	See Auto-Sync Service Parts List
600	See Separator Filter Service Parts List
800	See Balance Valve Service Parts List
890	See Air Pressure Gauge Service Parts List
900	PMC Subassembly

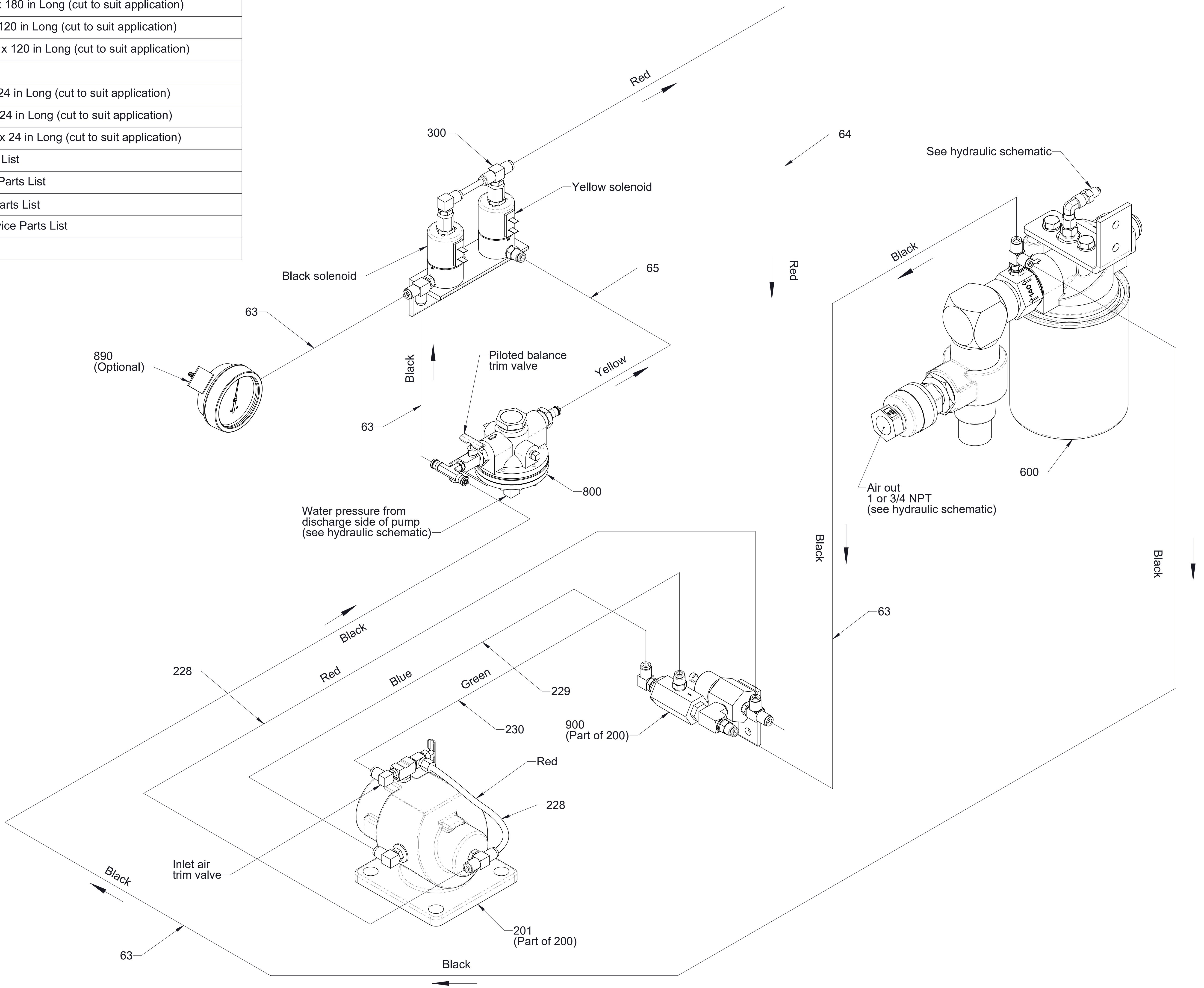

**Schematic-Air**  
Traditional CAFS

Ref No.	Description
63	Black Air Brake Tube, 1/4 in x 180 in Long (cut to suit application)
201	Inlet-Air, 90°
228	Red Air Brake Tube, 1/4 in x 24 in Long (cut to suit application)
229	Blue Air Brake Tube, 1/4 in x 24 in Long (cut to suit application)
230	Green Air Brake Tube, 1/4 in x 24 in Long (cut to suit application)
600	See Separator Filter Service Parts List
900	PMC Subassembly

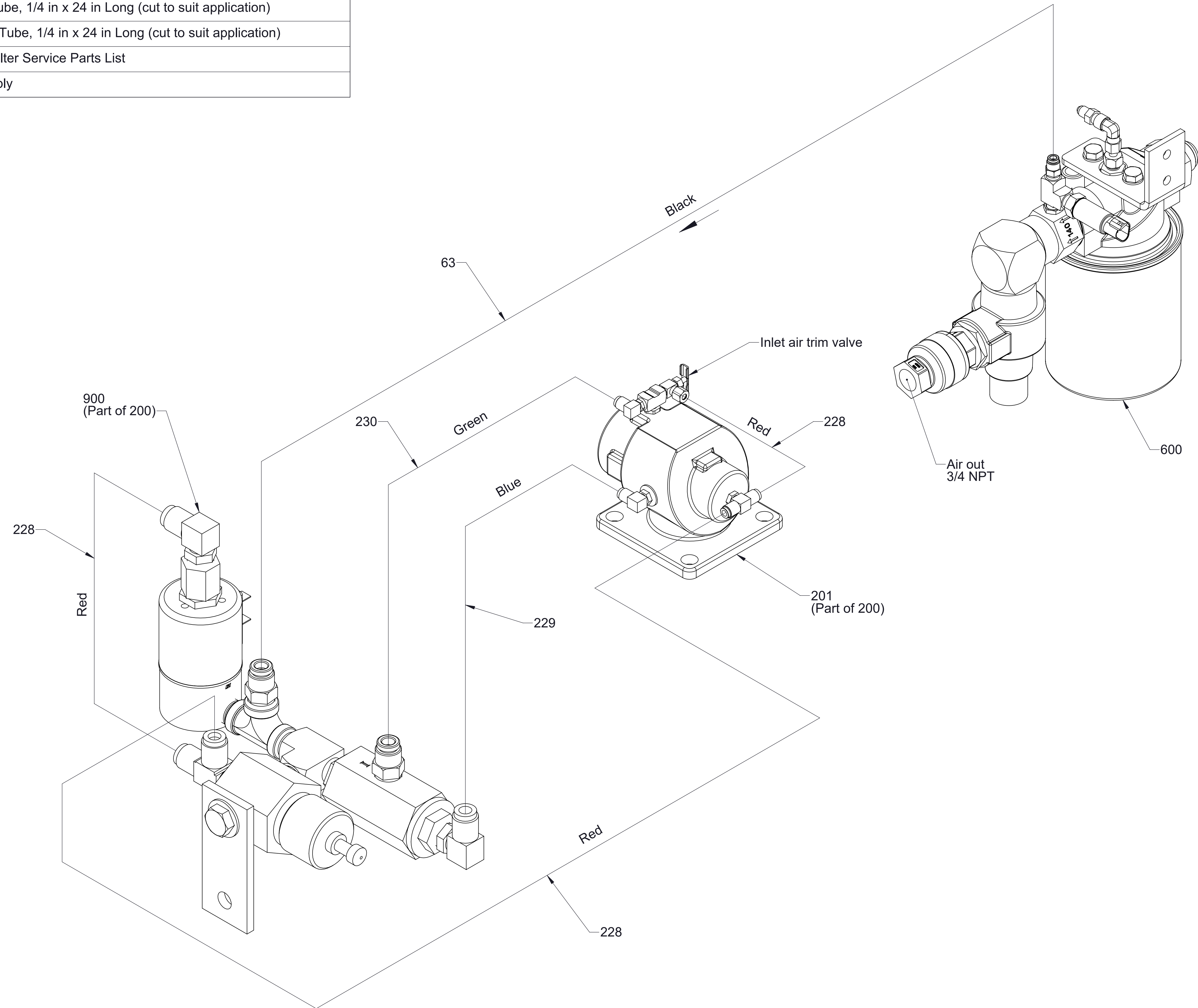

**Schematic-Air**  
 Generated CAFS  
 Models 150-OS, 150-ECL  
 Without High Rise



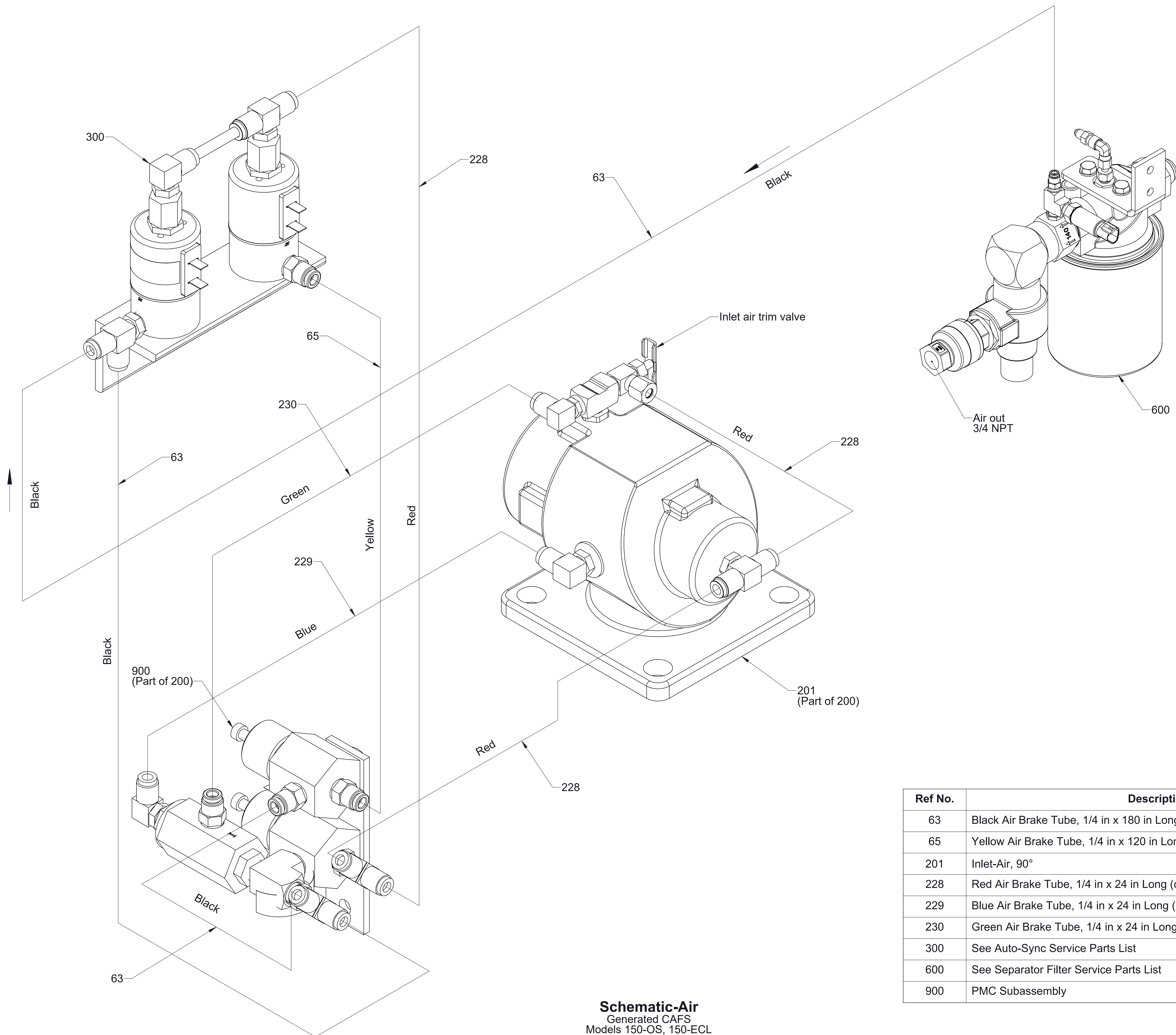

**Schematic-Air**  
 Generated CAFS  
 Models 150-OS, 150-ECL  
 With High Rise

Ref No.	Description
63	Black Air Brake Tube, 1/4 in x 180 in Long (cut to suit application)
65	Yellow Air Brake Tube, 1/4 in x 120 in Long (cut to suit application)
201	Inlet-Air, 90°
228	Red Air Brake Tube, 1/4 in x 24 in Long (cut to suit application)
229	Blue Air Brake Tube, 1/4 in x 24 in Long (cut to suit application)
230	Green Air Brake Tube, 1/4 in x 24 in Long (cut to suit application)
300	See Auto-Sync Service Parts List
600	See Separator Filter Service Parts List
900	PMC Subassembly

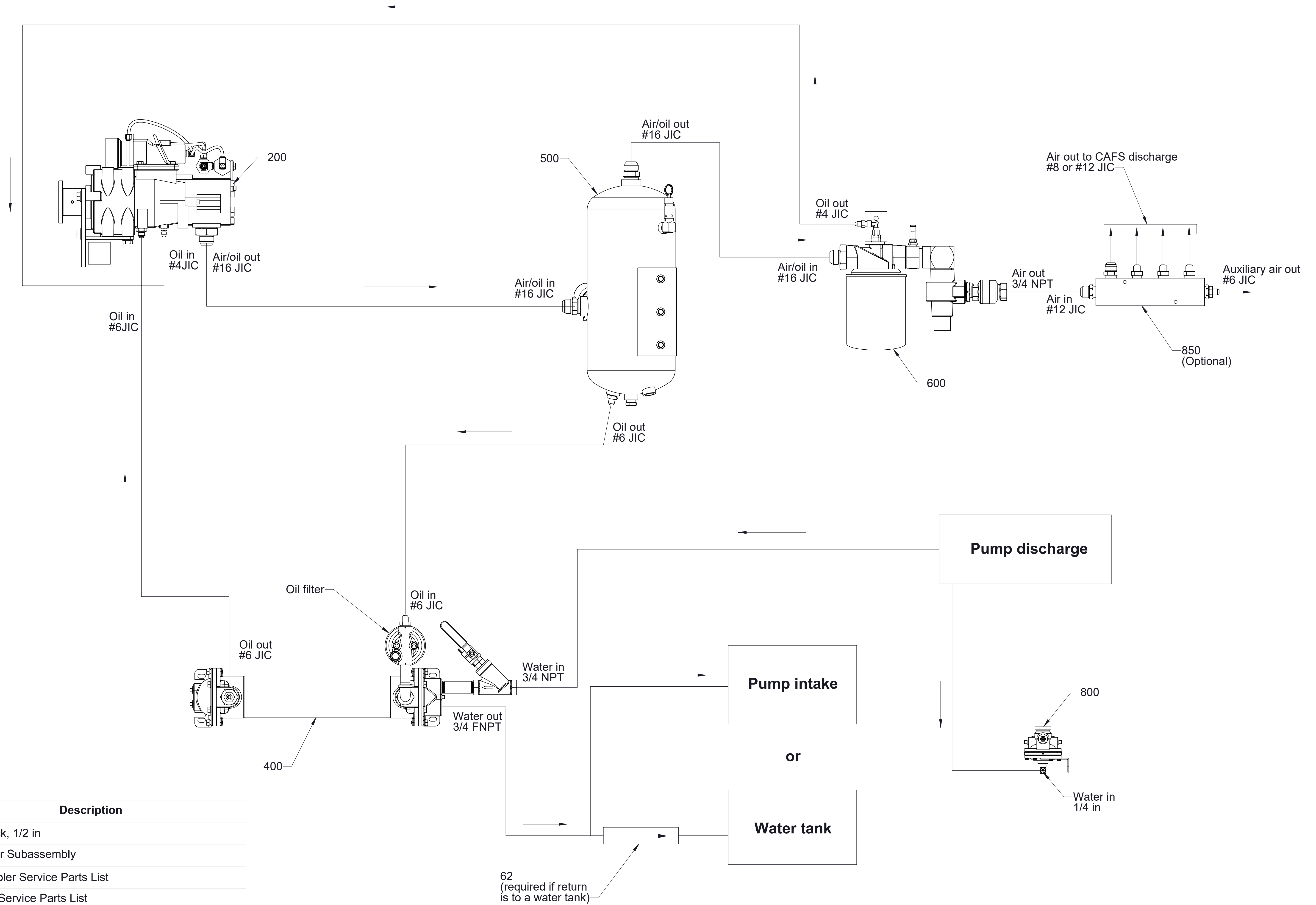

Ref No.	Description
62	Valve-Check, 1/2 in
200	Compressor Subassembly
400	See Oil Cooler Service Parts List
500	See Sump Service Parts List
600	See Separator Filter Service Parts List
800	See Balance Valve Service Parts List
850	See Air Manifold Service Parts List

**Schematic-Hydraulic**  
Model 80-P

Note: Air manifold, hoses and fittings are optional from Waterous and may have been furnished by OEM. See Air Manifold and Hose and Fitting Kit Service Parts List.



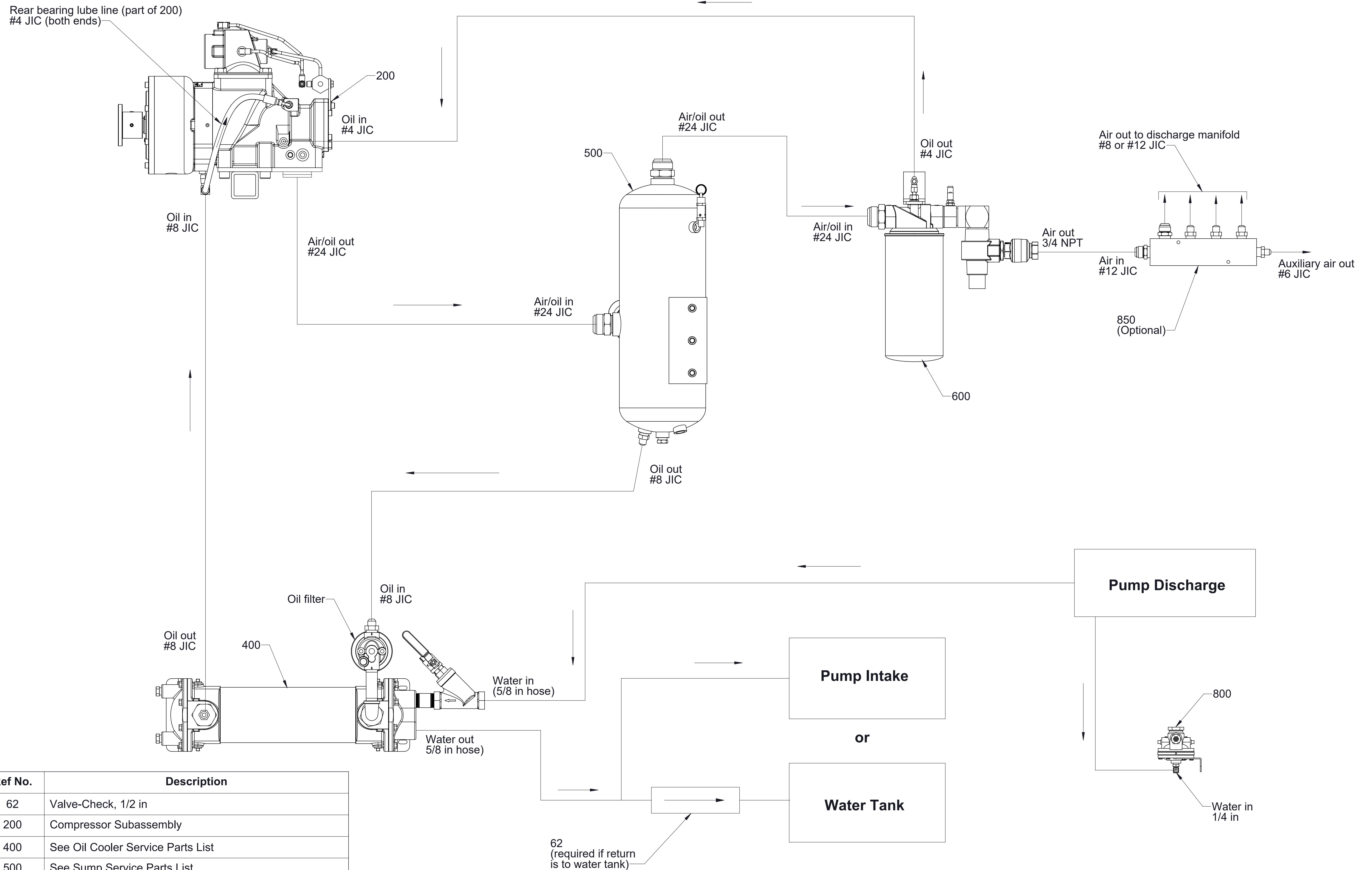

Ref No.	Description
62	Valve-Check, 1/2 in
200	Compressor Subassembly
400	See Oil Cooler Service Parts List
500	See Sump Service Parts List
600	See Separator Filter Service Parts List
800	See Balance Valve Service Parts List
850	See Air Manifold Service Parts List

**Schematic-Hydraulic**  
Model 140-P

Note: Air manifold, hoses and fittings are optional from Waterous and may have been furnished by OEM. See Air Manifold and Hose and Fitting Kit Service Parts List.

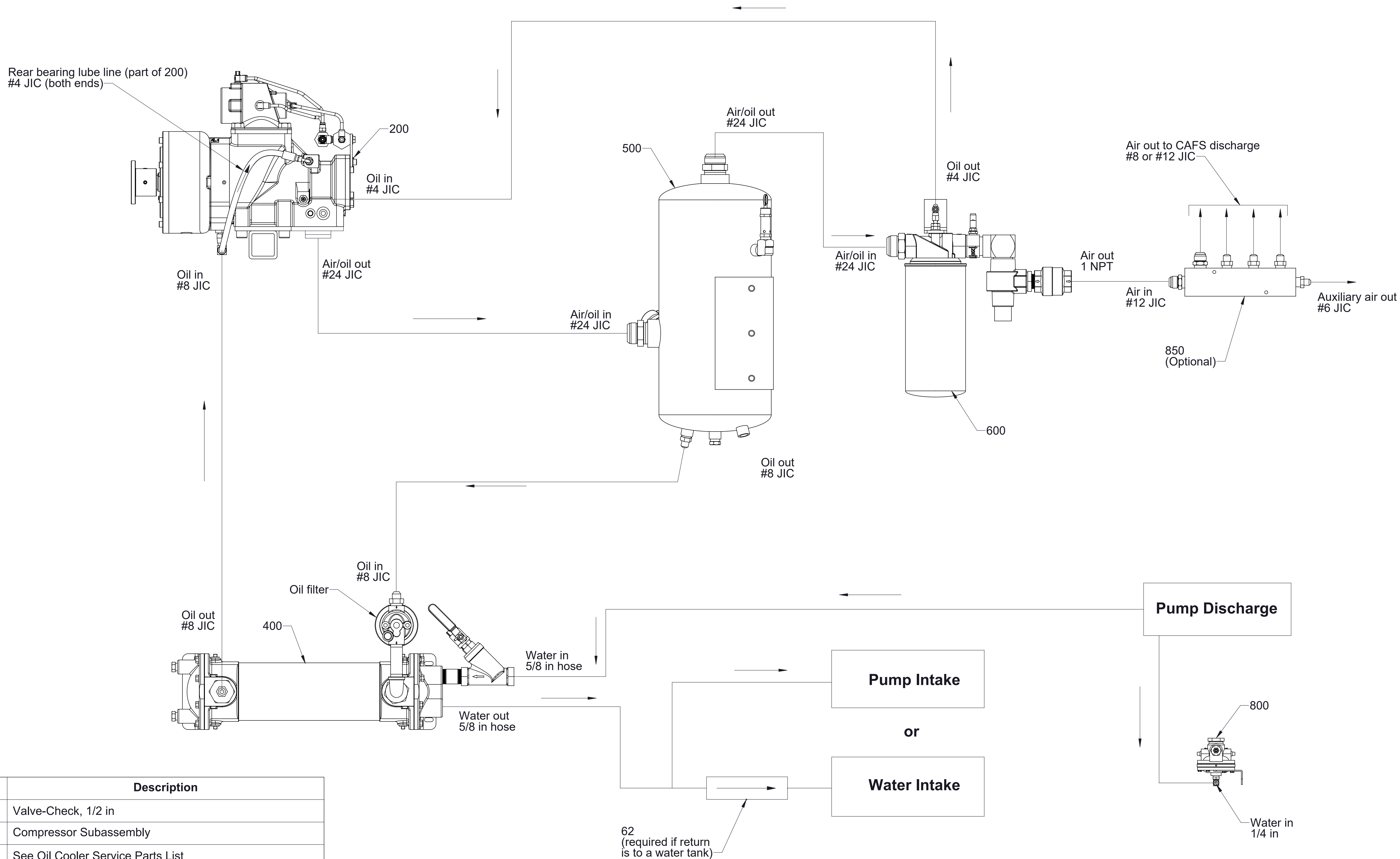

Ref No.	Description
62	Valve-Check, 1/2 in
200	Compressor Subassembly
400	See Oil Cooler Service Parts List
500	See Sump Service Parts List
600	See Separator Filter Service Parts List
800	See Balance Valve Service Parts List
850	See Air Manifold Service Parts List

**Schematic-Hydraulic**  
Model 200-P

Note: Air manifold, hoses and fittings are optional from Waterous and may have been furnished by OEM. See Air Manifold and Hose and Fitting Kit Service Parts List.



Rear bearing lube line (part of 200)  
#4 JIC (both ends)

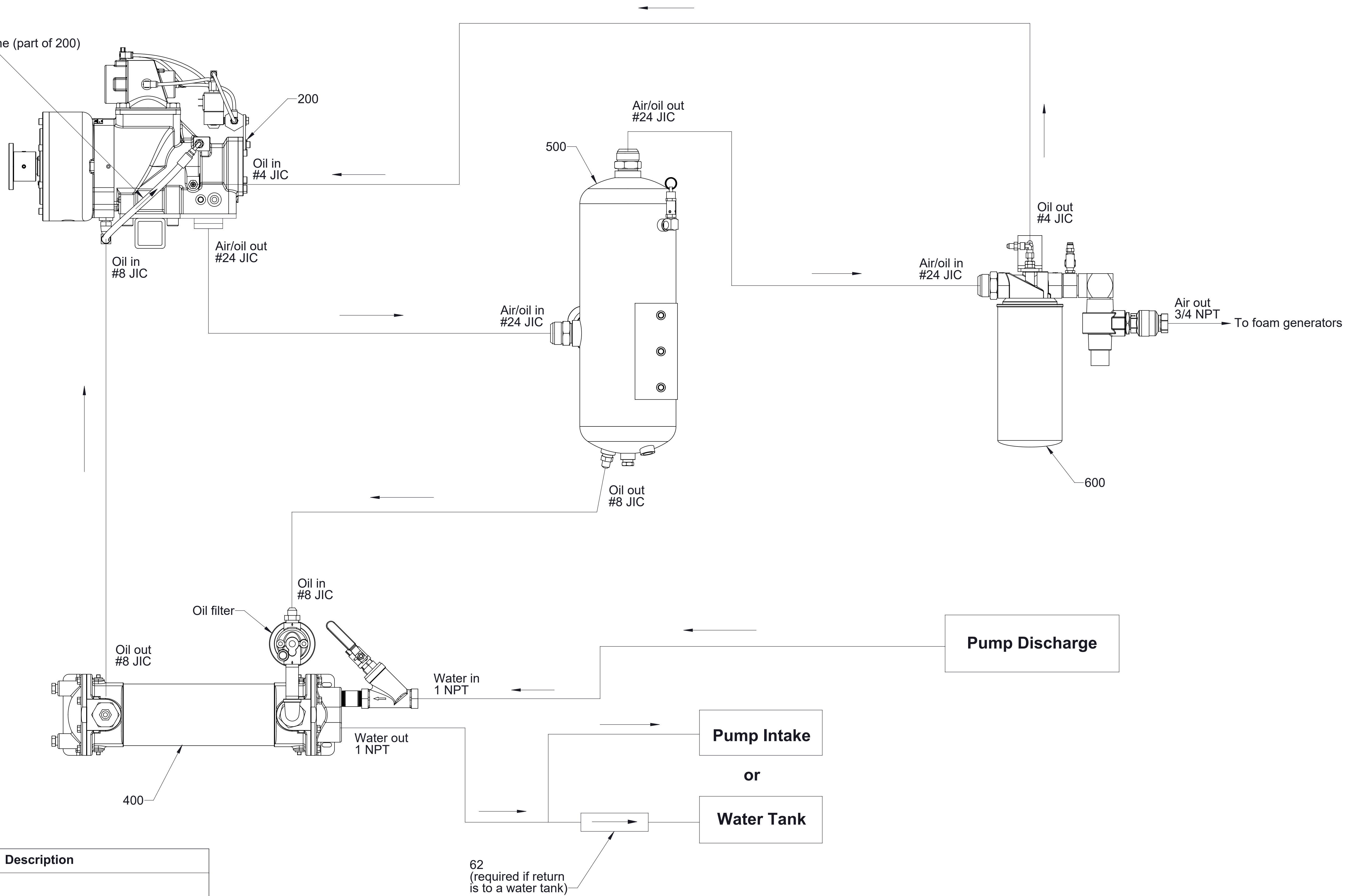

Ref No.	Description
62	Valve-Check, 1/2 in
200	Compressor Subassembly
400	See Oil Cooler Service Parts List
500	See Sump Service Parts List
600	See Separator Filter Service Parts List

**Schematic-Hydraulic**  
Model 150-OS, 150-ECL  
Generated CAFS

Note: Hoses and fittings are optional from Waterous and may have been furnished by OEM.  
See Hose and Fitting Kit Service Parts List.

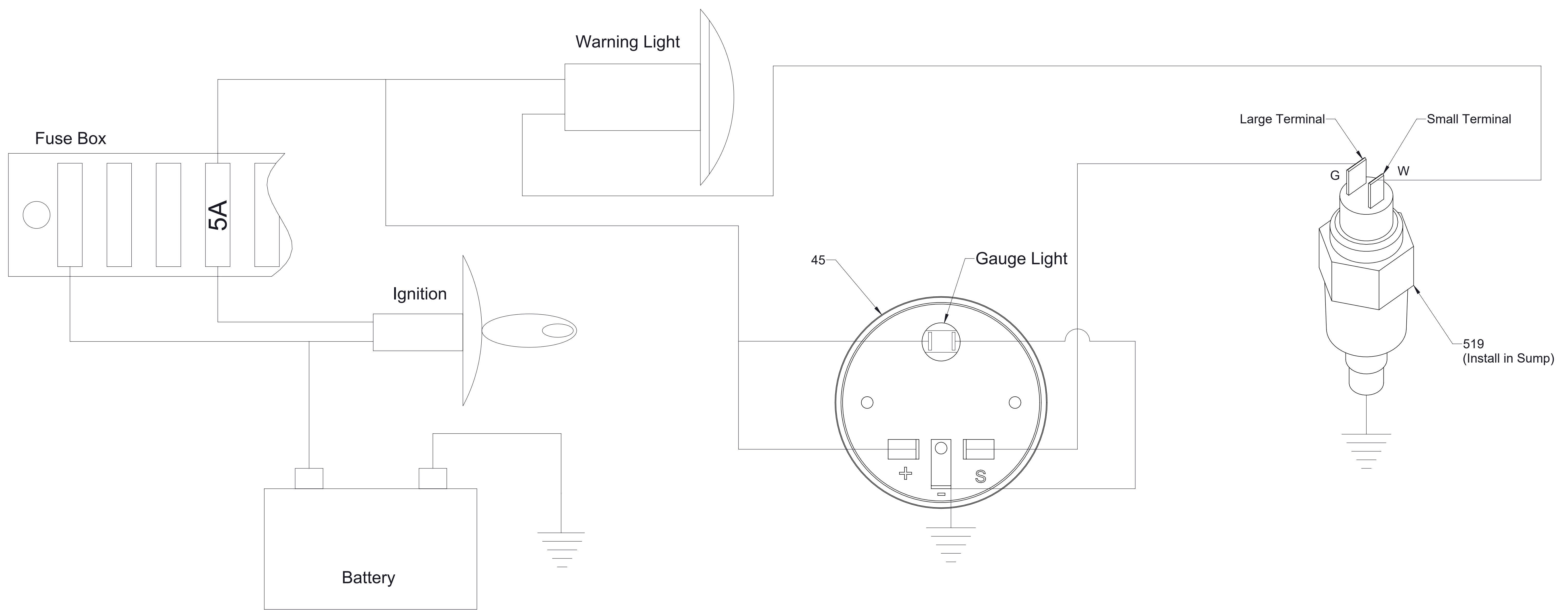

Note: Typical installation, all wiring, warning light, fuse, ignition switch and battery furnished by OEM.

### Sump Temperature Sender and Oil Temperature Gauge

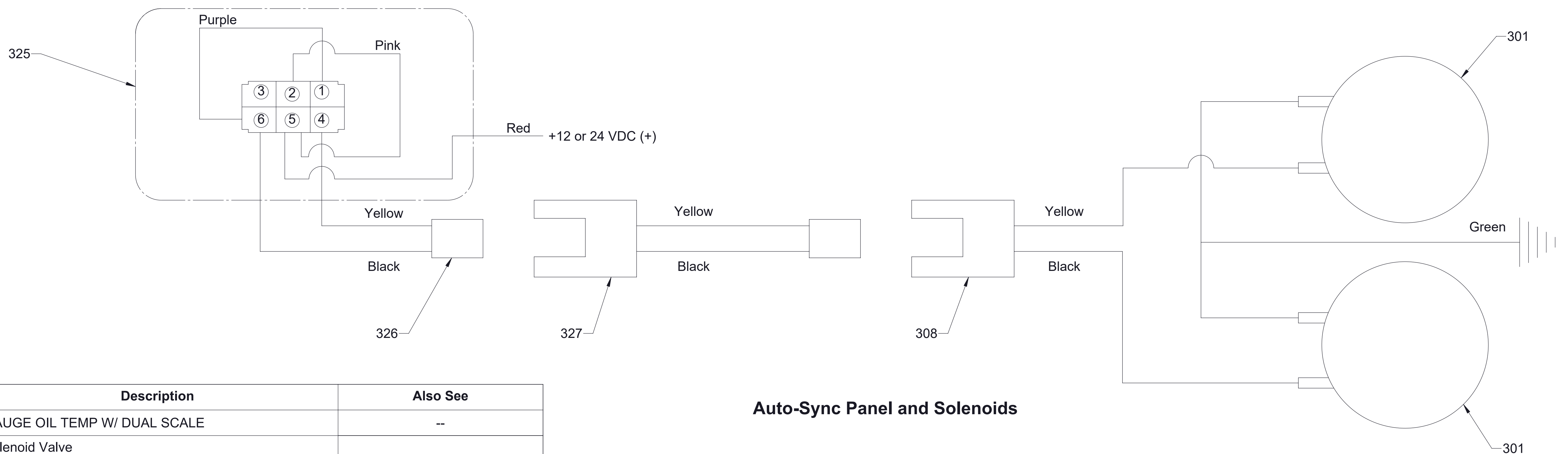

### Auto-Sync Panel and Solenoids

**Schematic-Electrical**  
Traditional CAFS

Ref No.	Description	Also See
45	GAUGE OIL TEMP W/ DUAL SCALE	--
301	Solenoid Valve	Auto-Sync Service Parts List
308	Electric Auto-Sync Wiring Harness	
325	Electric Auto-Sync Plate	
326	Electric Auto-Sync Switch Harness	
327	Harness-Extension, Auto-Sync, 15 Feet	Sump Service Parts List
519	TEMP SENDER VDO 323-010	

Note: See Foam Generator Service Parts List for Generated CAFS electrical schematic.