

## Air Compressor Service Parts List

### One-Step™ CAFS Model 150-OS

### Eclipse GEN 2.0 CAFS Model 150-ECL

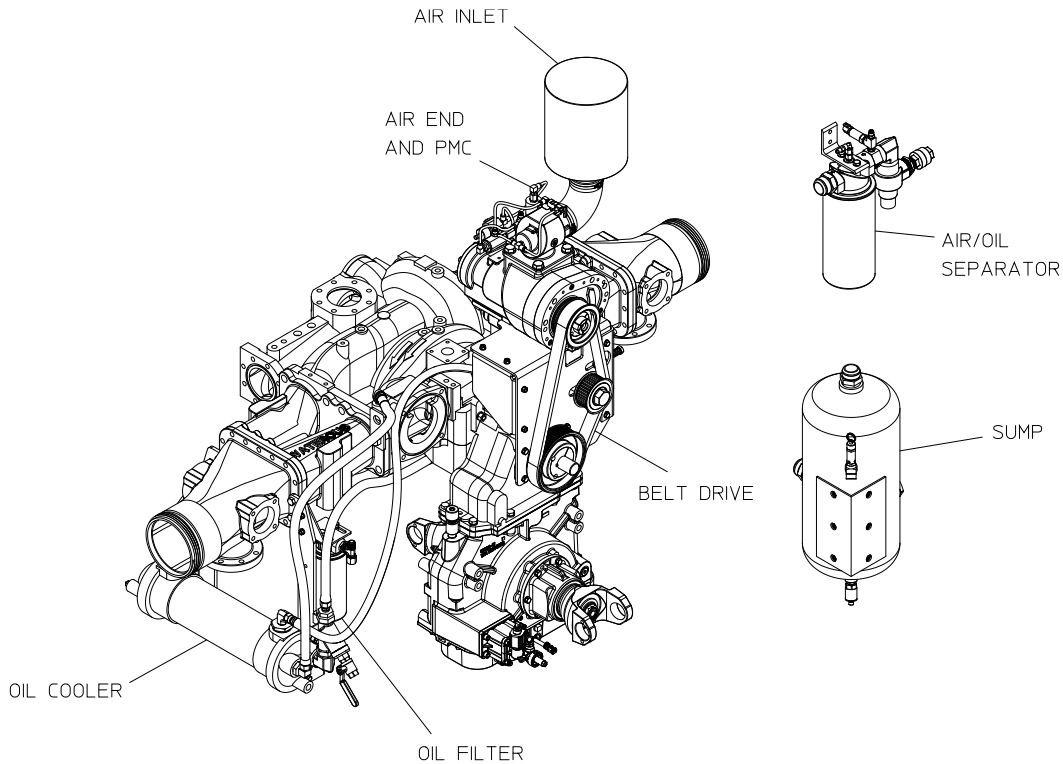

### Index:

Component		See Page		
		Non-High Rise Configuration	High Rise Configuration	
Compressor	Belt Drive	2, 3	2, 3	
	Mounting on Pump	4, 5	4, 5	
	Mounting on Brackets	6, 7	6, 7	
	Air End	8, 9	10, 11	
	Auto-Sync (High Rise Only)	--	12, 13	
	Air Inlet	14, 15	14, 15	
Air/Oil Separator		16, 17	16, 17	
Sump		18, 19	18, 19	
Oil Cooler and Oil Filter	In-Line Water Strainer	Mounting	20, 21	20, 21
		Components	22, 23	22, 23
		Oil Lines	36, 37	36, 37
	Panel Mounted Water Strainer	Water Lines	24, 25	24, 25
		Mounting	26, 27	26, 27
		Components	28, 29	28, 29
	Oil Lines	38, 39	38, 39	
	Water Lines	30, 31	30, 31	
Schematic	Air Circuit		32, 33	34, 35
	Hydraulic	In-Line Strainer	36, 37	36, 37
		Panel Strainer	38, 39	38, 39
	Electrical	See Foam Generator Service Parts List		
Hose and Fitting Kit		Optional from Waterous, See Service Parts List SPL83368		

## Compressor – Belt Drive

REF NO.	DESCRIPTION
29	Poly Chain Belt, 8GMT-1280-36
30	Driven Sprocket, 8MX-42S-TL2012
31	Taperlock Bushing, 45mm Bore
32	Idler Sprocket, 8MX-36S-36

REF NO.	DESCRIPTION
33	Belt Tensioner Spacer
34	Drive Sprocket, 8MX-67S-36
35	Taperlock Bushing, .375 in. Bore

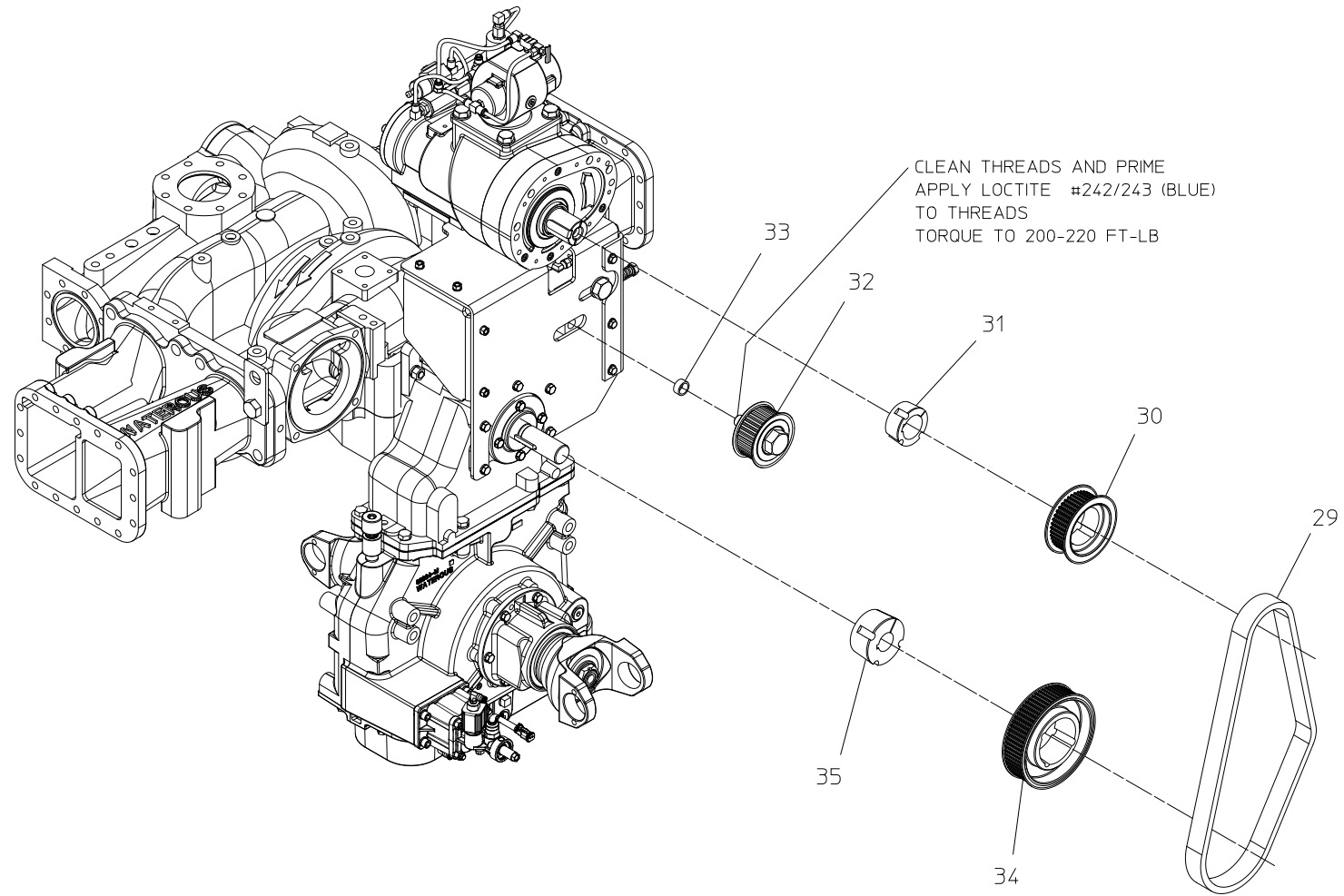

**COMPRESSOR BELT DRIVE**

## Compressor – Mounting on Pump

REF NO.	DESCRIPTION
27	Lock Washer, M6
28	Hex Head Screw, M16-2.0 x 30mm
70	CAFS Warning Plate

REF NO.	DESCRIPTION
100	Serial Plate
200	Compressor Subassembly

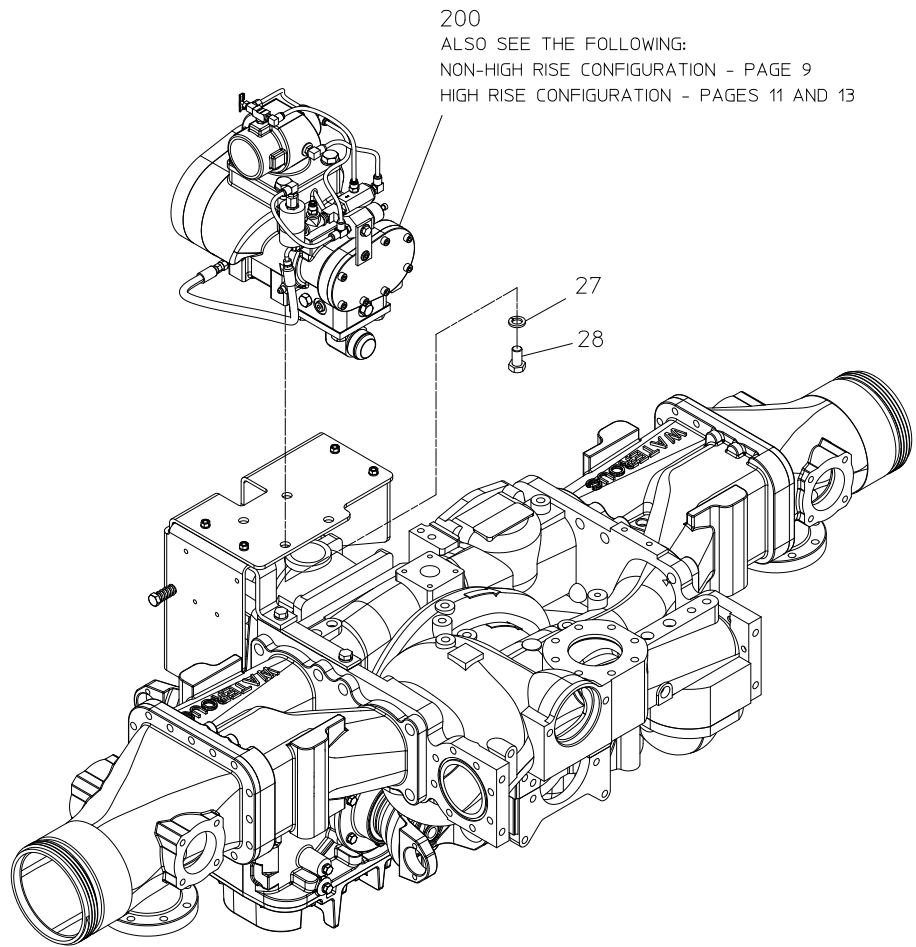

200  
 ALSO SEE THE FOLLOWING:  
 NON-HIGH RISE CONFIGURATION - PAGE 9  
 HIGH RISE CONFIGURATION - PAGES 11 AND 13

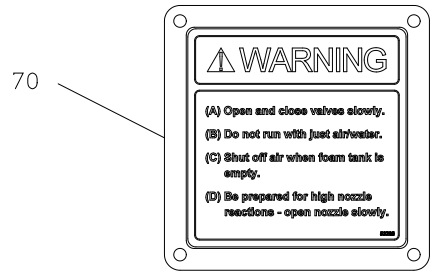
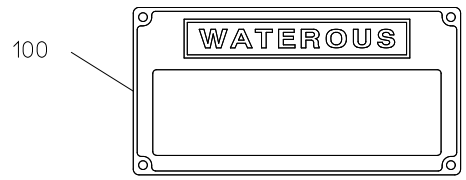

**COMPRESSOR MOUNTING ON PUMP**

## Compressor – Mounting Brackets

REF NO.	DESCRIPTION
2	Top Mounting Bracket
3	RH Mounting Bracket
4	LH Mounting Bracket
5	Compressor Tank Shim
6	Compressor Support Bracket
7	Lifting Lug
8	Belt Tensioner Block
9	Belt Tensioner Spring
10	Hex Head Screw, ½-13 x 6 in.
11	Hex Head Screw, ¾-16 x 1 in. or 3/4-16 x 1-1/4 in.
12	Plain Washer, ¾ in.
13	Hex Nut, 5/16-18

REF NO.	DESCRIPTION
14	Lock Washer, 5/16 in.
15	Hex Head Screw, 3/8-16 x 1 in.
16	Lock Washer, 3/8 in.
17	Hex Head Screw, 5/16-18 x 7/8 in.
18	Plain Washer, 5/16 in.
19	Hex Head Screw, ½-13 x 1-1/4 in.
20	Lock Washer, ½ in.
21	Hex Head Screw, ½-13 x 1 in.
22	Hex Head Screw, ¾-10 x 2-1/4 in.
57	Hex Head Screw, 5/16-18 x 1-1/4 in.

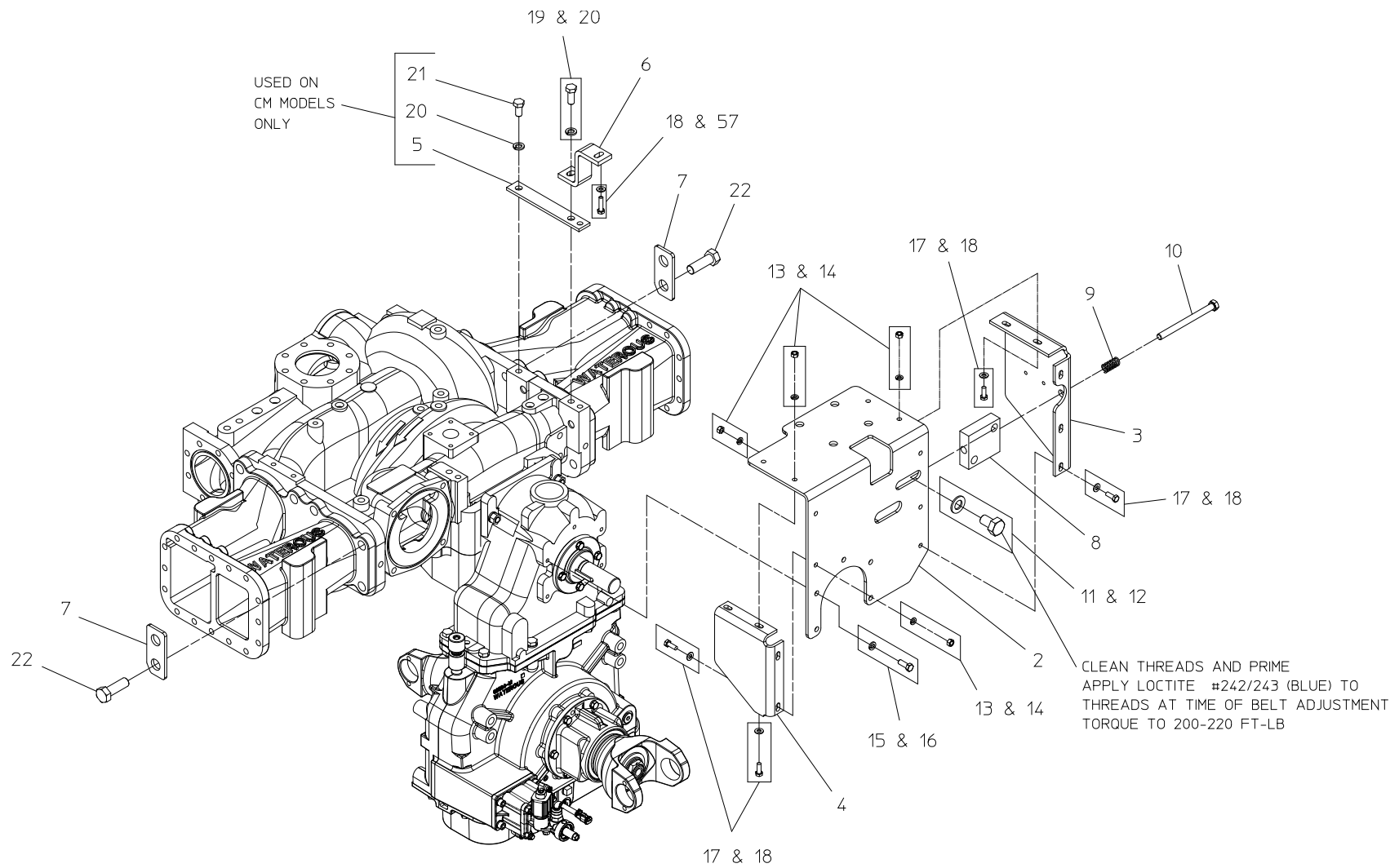

**COMPRESSOR MOUNTING BRACKETS**

## Compressor – Air End Non-High Rise Configuration

REF NO.	DESCRIPTION
200	Compressor Subassembly (includes 201-238 and 900)
201	90 Degree Air Inlet, 2-1/2 in.
202	Reducing Bushing, ¼ MNPT x 1/8 FNPT
203	Male Branch Tee, 1/8 MNPT x 1/8 FNPT x 1/8 FNPT
204	Trim Valve, 1/8 MNPT x ¼ AB
205	90 Degree Elbow, 1/8 MNPT x ¼ AB
206	90 Degree Elbow, ¼ MNPT x ¼ AB
207	Male Branch Tee, ¼ MNPT x ¼ AB x ¼ AB
214	Straight Adapter, 4 MJIC x 12mm
217	Oil Injection Hose Assembly (Straight x 90 Degrees)
218	Oil Return Fitting, 8 MJIC x 8 FJIC x 4 MJIC (90 Degrees)
222	Air Outlet Gasket
223	Oil Injection Fitting, 8 MJIC x M22-1.5
224	Outlet Flange, 1-1/2 FNPT
225	90 Degree Street Elbow, 1-1/2 NPT
227	Air End, CF75D8
228	Red Air Brake Tube, ¼ in. (Cut to Length)
229	Blue Air Brake Tube, ¼ in. (Cut to Length)
230	Green Air Brake Tube, ¼ in. (Cut to Length)

REF NO.	DESCRIPTION
231	Compressor Replacement Kit
232	O-ring, 3-7/8 x 4-1/4 in.
235	Hex Head Screw, M16-2.0 x 30mm
237	Flat Washer, 8mm
238	Flat Washer, 16mm
241	Internal Support Sleeve
247	Shaft Seal Repair Kit
900	PMC Subassembly (Includes 901-912)
901	Pressure Regulator
902	Blowdown Valve
903	PMC Mounting Bracket
904	Straight Adapter, ¼ MNPT x ¼ AB
905	90 Degree Elbow, ¼ MNPT x ¼ AB
907	AB Branch Tee, ¼ AB x ¼ MNPT x ¼ AB
908	Flat Washer, 3/8 in.
909	Hex Head Screw, 3/8-16 x ½ in.
910	Solenoid Valve
911	Pipe Nipple, ¼ MNPT x 7/8 in.
912	Pipe Tee, ¼ FNPT
914	Female Street Tee, ¼ FNPT



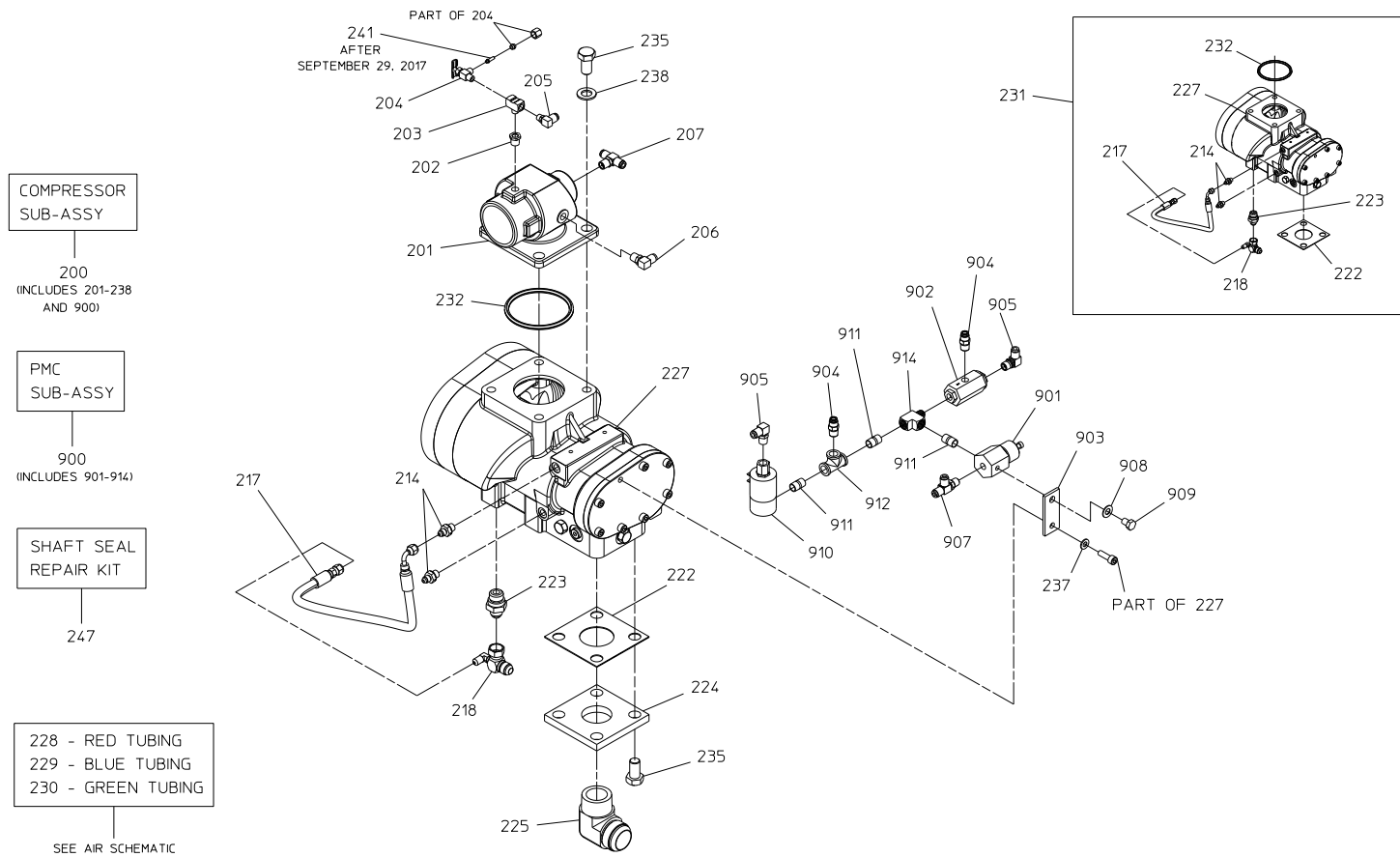

**COMPRESSOR AIR END**  
NON-HIGH RISE CONFIGURATION

## Compressor – Air End High Rise Configuration

REF NO.	DESCRIPTION
200	Compressor Subassembly (includes 201-238 and 900)
201	90 Degree Air Inlet, 2-1/2 in.
202	Reducing Bushing, ¼ MNPT x 1/8 FNPT
203	Male Branch Tee, 1/8 MNPT x 1/8 FNPT x 1/8 FNPT
204	Trim Valve, 1/8 MNPT x ¼ AB
205	90 Degree Elbow, 1/8 MNPT x ¼ AB
206	90 Degree Elbow, ¼ MNPT x ¼ AB
207	Male Branch Tee, ¼ MNPT x ¼ AB x ¼ AB
214	Straight Adapter, 4 MJIC x 12mm
217	Oil Injection Hose Assembly (Straight x 90 Degrees)
218	Oil Return Fitting, 8 MJIC x 8 FJIC x 4 MJIC (90 Degrees)
222	Air Outlet Gasket
223	Oil Injection Fitting, 8 MJIC x M22-1.5
224	Outlet Flange, 1-1/2 FNPT
225	90 Degree Street Elbow, 1-1/2 NPT
227	Air End, CF75D8
228	Red Air Brake Tube, ¼ in. (Cut to Length)
229	Blue Air Brake Tube, ¼ in. (Cut to Length)
230	Green Air Brake Tube, ¼ in. (Cut to Length)
239	Black Air Brake Tube, ¼ in. (Cut to Length)

REF NO.	DESCRIPTION
231	Compressor Replacement Kit
232	O-ring, 3-7/8 x 4-1/4 in.
235	Hex Head Screw, M16-2.0 x 30mm
237	Flat Washer, 8mm
238	Flat Washer, 16mm
241	Internal Support Sleeve
247	Shaft Seal Repair Kit
900	PMC Subassembly (Includes 901-914)
901	Pressure Regulator
902	Blowdown Valve
903	PMC Mounting Bracket
904	Straight Adapter, ¼ MNPT x ¼ AB
905	90 Degree Elbow, ¼ MNPT x ¼ AB
907	AB Branch Tee, ¼ AB x ¼ MNPT x ¼ AB
908	Flat Washer, 3/8 in.
909	Hex Head Screw, 3/8-16 x ½ in.
911	Pipe Nipple, ¼ MNPT x 7/8 in.
914	Female Street Tee, ¼ FNPT

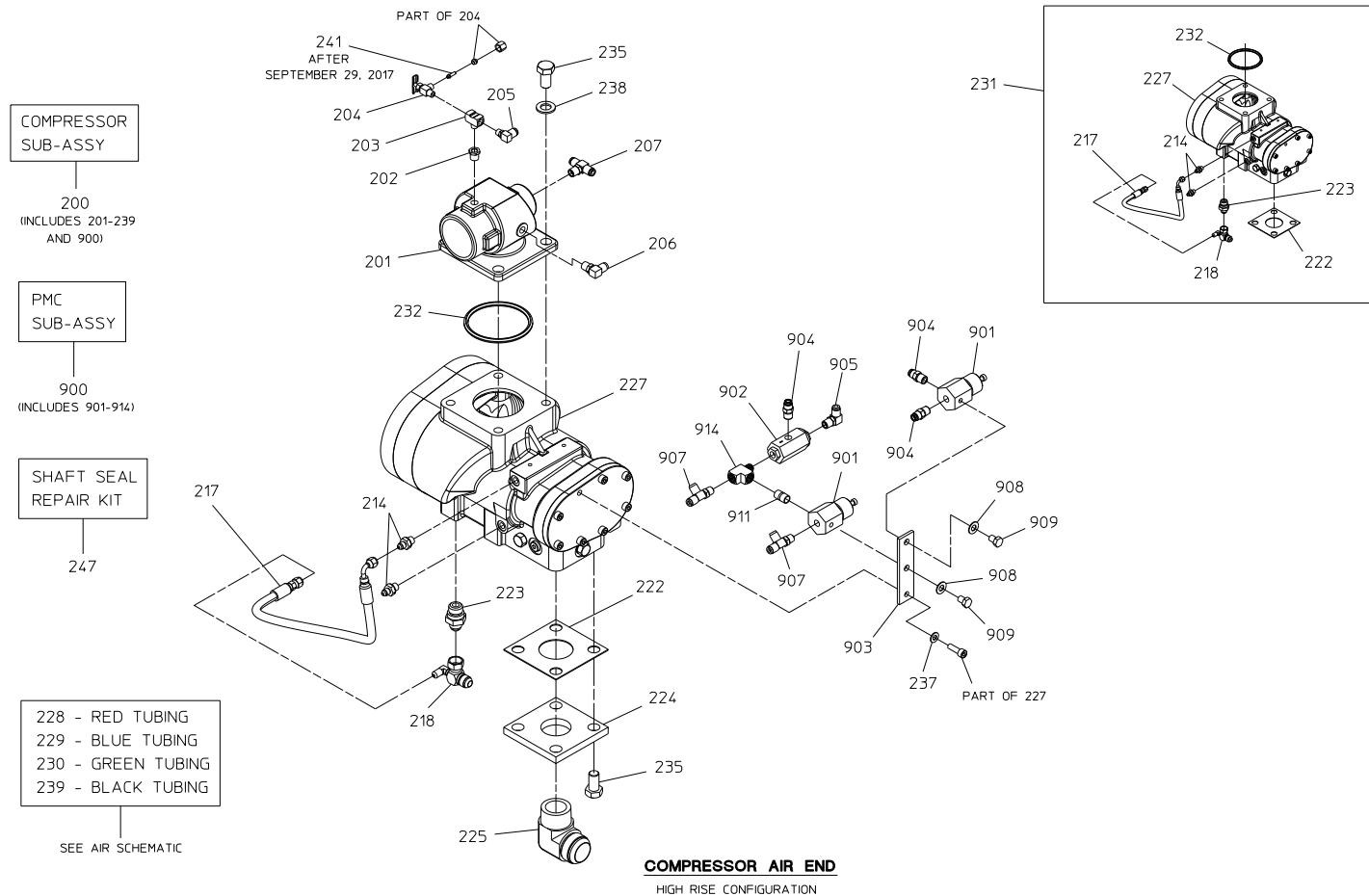

**Compressor – Auto Sync  
Used on High Rise Configuration Only**

REF NO.	DESCRIPTION
3	Top Compressor Mounting Bracket
24	Plain Washer, ¼ in.
25	Hex Head Screw, ¼-20 x ¾ in.
26	Nylok Hex Nut, ¼-20
47	Black Air Brake Tube, ¼ in. (Cut to Length)
48	Red Air Brake Tube, ¼ in. (Cut to Length)
49	Yellow Air Brake Tube, ¼ in. (Cut to Length)
300	Auto-Sync Subassembly (Includes 301-311)
301	Solenoid Valve

REF NO.	DESCRIPTION
302	Male Connector, ¼ MNPT x ¼ AB
303	90 Degree Elbow, ¼ MNPT x ¼ AB
304	Male Branch Tee, ¼ AB x ¼ MNPT x ¼ AB
306	Red Air Brake Tube, ¼ in. (Cut to Length)
307	Angle Solenoid Bracket
310	Pan Head Screw, No. 10-32 x ½ in.
311	90 Degree Street Elbow, 1-1/4 NPT

47 - BLACK TUBING  
48 - RED TUBING  
49 - YELLOW TUBING

SEE AIR SCHEMATIC

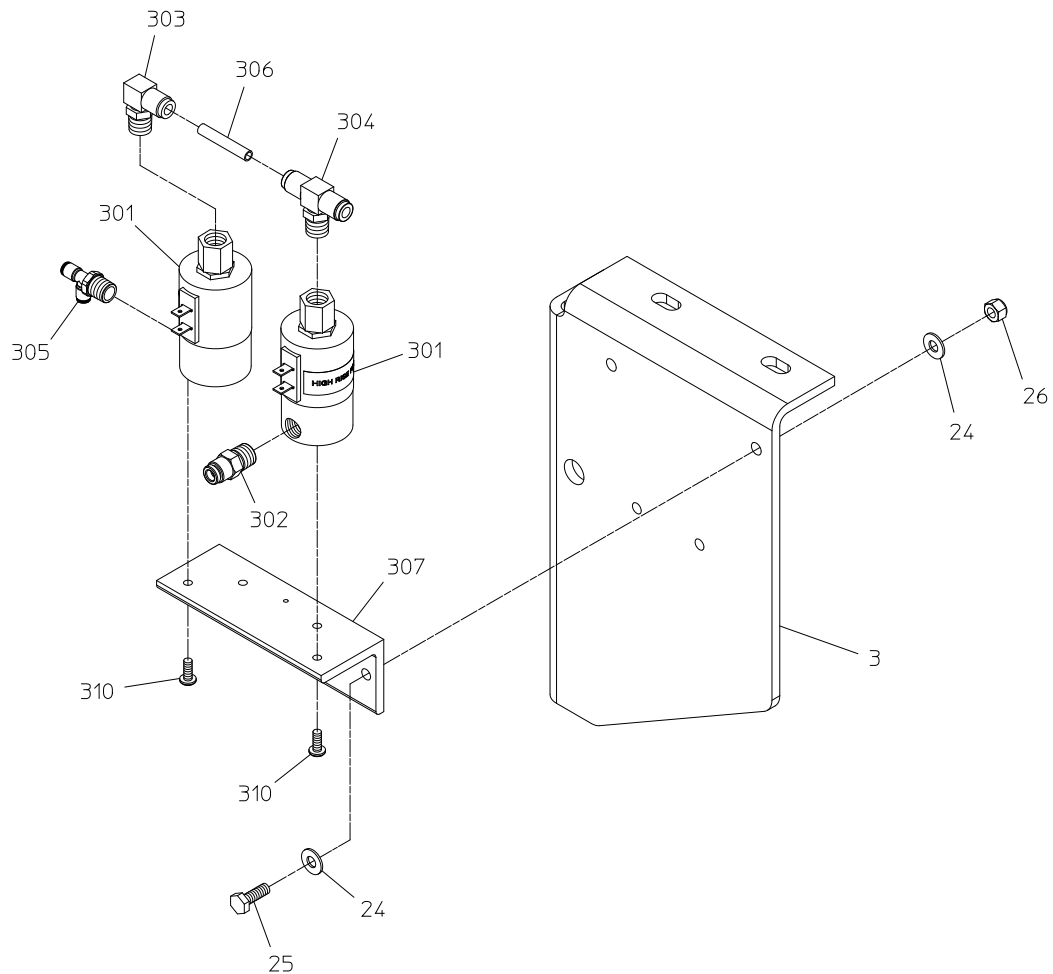

AUTO-SYNC  
SUB-ASSY

300  
(INCLUDES 301-310)

**COMPRESSOR AUTO-SYNC**

USED ON HIGH RISE CONFIGURATION ONLY

## Compressor – Air Inlet

REF NO.	DESCRIPTION
80	Inlet Adapter, 3 in. x 3 in.
81	Hose Clamp, 3-3/4 in.
82	T-Bolt Hose Clamp, 3-1/2 in.

REF NO.	DESCRIPTION
83	Air Filter, CO85005, 3 in.
84	90 Degree Rubber Elbow, 3 in.

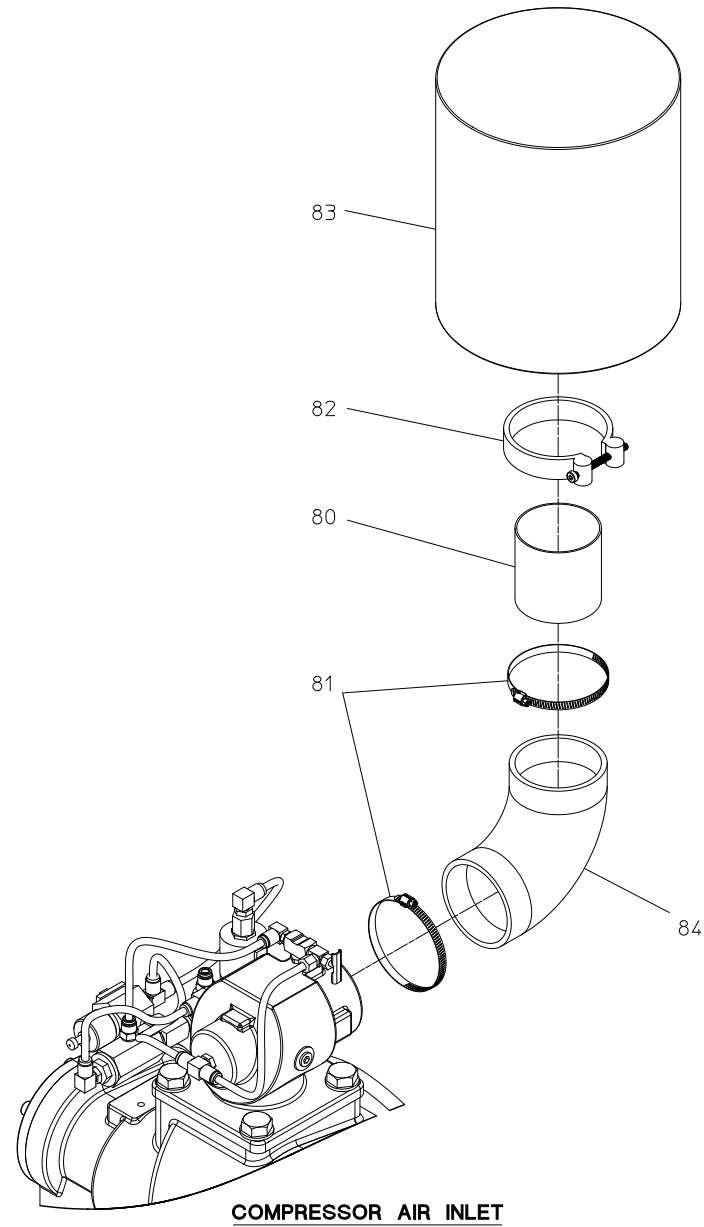

## Air/Oil Separator

REF NO.	DESCRIPTION
600	Separator Subassembly (Includes 601-625)
601	Scavenger Fitting (Includes Ferrule and Nut)
602	90 Degree Elbow, 24 MJIC x 1-1/4 MNPT
604	Large Separator Bracket
605	Scavenger Tube Assembly (Includes Ferrule and Nut)
606	Restrictor Fitting, 200, 3/8 in.
607	Large Filter Head
608	Large Separator Filter
609	90 Degree Street Elbow, 1-1/4 NPT
610	Close Nipple, 3/4 NPT
611	Minimum Pressure Control Valve, 1-1/4 in.

REF NO.	DESCRIPTION
612	Check Valve, 3/4 in.
613	Reducing Bushing, 1-1/4 NPT x 3/4 in. NPT
614	Hex Head Screw, M10-1.5 x 20mm
615	Flat Washer, 10mm
616	Tee, 1/4 FNPT x 1/4 MNPT x 1/4 FNPT
618	Copper Washer, 1.928 in OD
619	Headless Pipe Plug, 3/8 in. NPT
623	Minimum Pressure Control Valve Repair Kit
624	Straight Adapter, 1/4 MNPT x 1/4 AB
625	Pressure Transducer



SEE AIR AND  
HYDRAULIC SCHEMATICS  
FOR TUBING AND HOSES

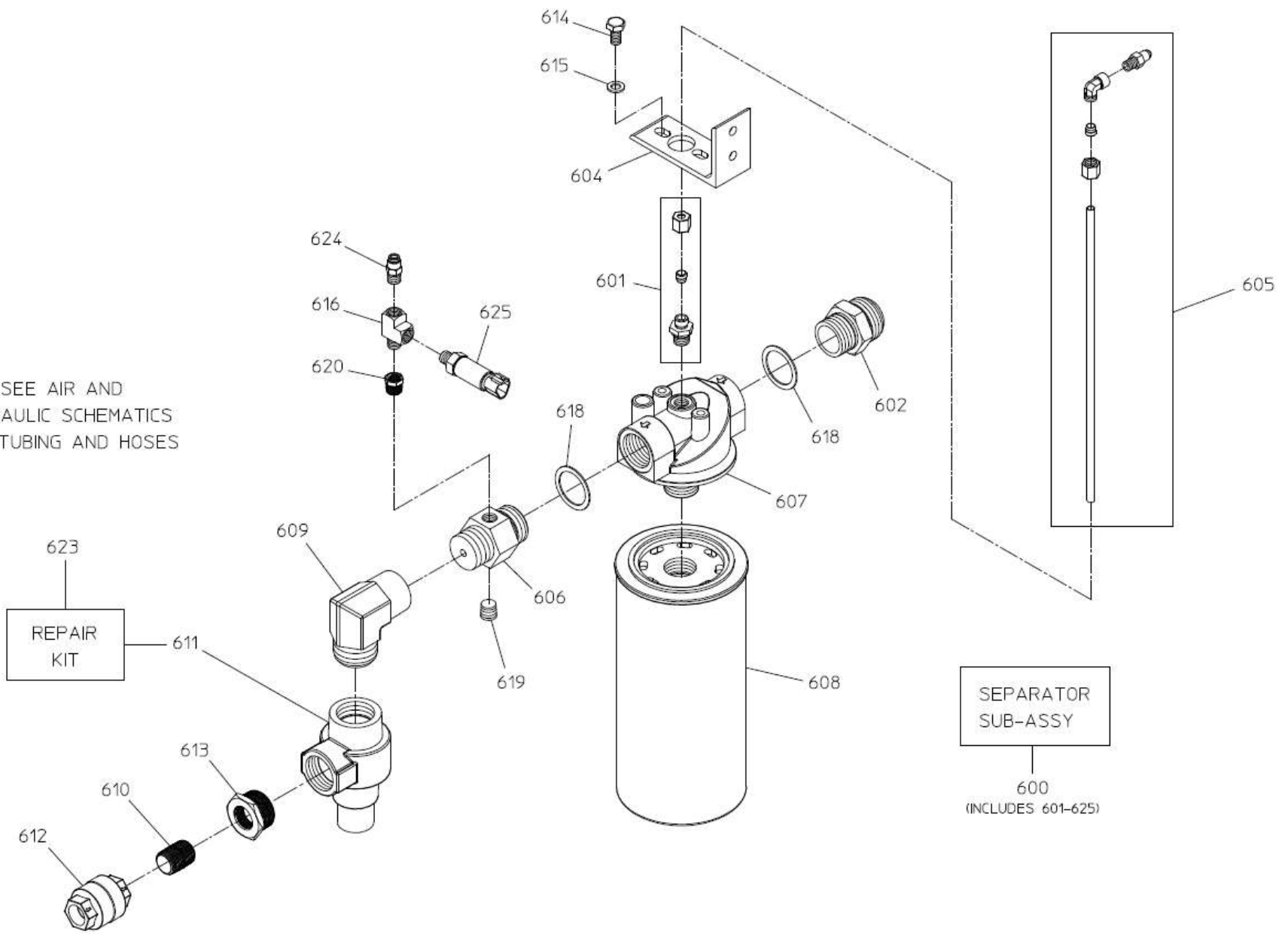

AIR/OIL SEPARATOR

## Sump

REF NO.	DESCRIPTION
73	Temperature Sender
78	Reducing Bushing, ½ in. NPT x ¼ in. NPT
500	Sump Subassembly (Includes 501-513)
501	Vertical Sump, 10 in.
502	90 Degree Street Elbow, ½ NPT
503	Pop Off Valve, ½ in.
504	90 Degree Male Elbow, 24 MJIC x 1-1/2 MNPT

REF NO.	DESCRIPTION
505	Cap with Chain, 1 in. NPSH
506	Nipple, 1-1/2 in. NPT x 1 in. NPSH
507	Sight Glass, 1-1/2 in.
512	Hex Head Plug, ½ NPT
513	Straight Adapter, ½ MNPT x 8 MJIC

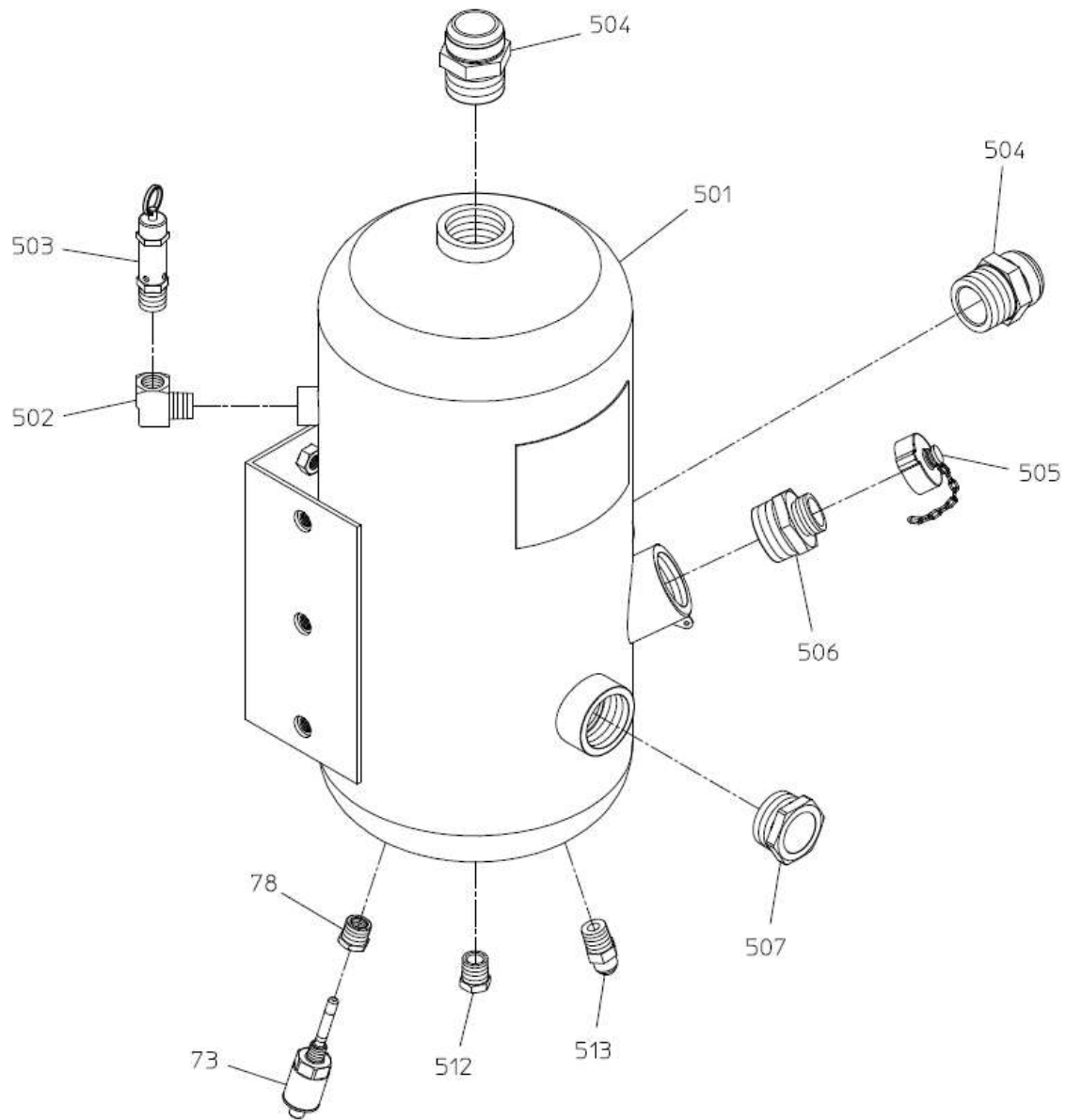

SUMP  
SUB-ASSY

500  
(INCLUDES 501-513)

SEE HYDRAULIC  
SCHEMATIC FOR HOSES

SUMP

**Oil Cooler and Oil Filter  
In-Line Water Strainer - Mounting**

REF NO.	DESCRIPTION
14	Lock Washer, 5/16 in.
18	Plain Washer, 5/16 in.
36	Oil Cooler Saddle Bracket
37	Hex Head Screw, ½-13 x 2 in.
38	Hex Head Screw, 5/16-24 x 1 in.
39	Hex Head Screw, 7/16-20 x 1-1/4 in.

REF NO.	DESCRIPTION
40	Plain Washer, 7/16 in.
41	Lock Washer, 7/16 in.
42	Hex Nut, 7/16-20
58	Hex Nut, 5/16-24
400	Oil Cooler Subassembly
700	Oil Filter Subassembly

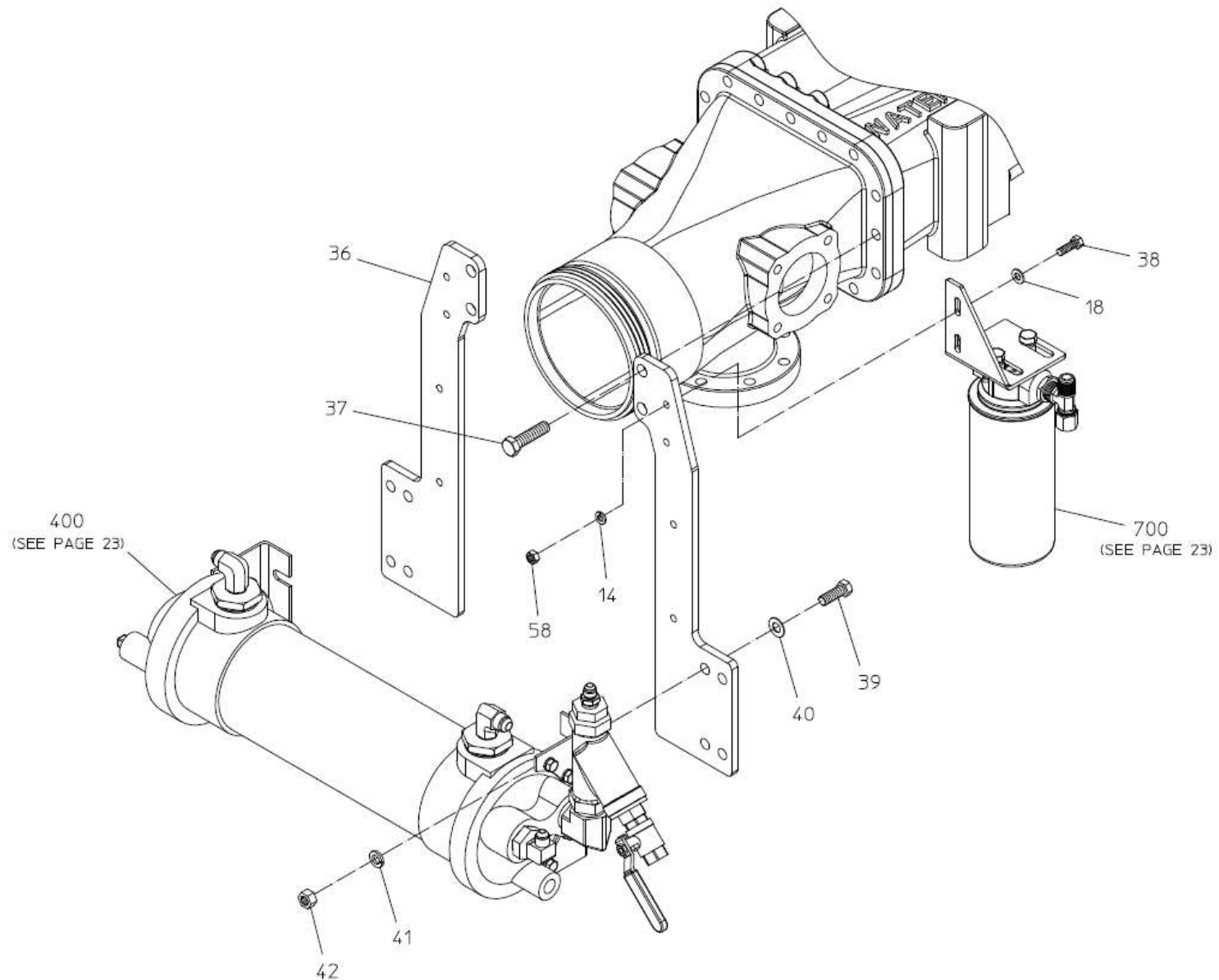

OIL COOLER AND OIL FILTER  
IN-LINE WATER STRAINER  
MOUNTING

## Oil Cooler and Oil Filter In-Line Water Strainer - Components

REF NO.	DESCRIPTION
400	Oil Cooler Subassembly (Includes 406-419)
406	Large Iron Cooler (Includes Brackets and Pipe Plugs)
408	Reducing Bushing, 1-1/2 NPT x ½ NPT
410	Wye Strainer Assembly, 1 in. (Includes 412 and 413)
412	Strainer Screen, 1 in.
413	Strainer Gasket, 1 in.
414	Reducing Bushing, 1 MNPT x ½ FNPT
415	Ball Valve, ½ MNPT x ½ FNPT
416	90 Degree Elbow, 8 MJIC x ½ MNPT
417	90 Degree Elbow, 6 MSAE x ½ MNPT
418	Straight Adapter, 6 MSAE x ½ MNPT
419	90 Degree Elbow, 1 MNPT

REF NO.	DESCRIPTION
700	Oil Filter Subassembly (Includes 701-709)
701	Filter Bracket
702	Large Filter Head
703	Oil Filter, WD962
704	Straight Adapter, 8 MJIC x ¾ MNPT
705	Hex Head Screw, 1/4-20 x 5/8 in.
706	Flat Washer, 1/4 in.
707	Reducing Bushing, ¾ MNPT x ½ FNPT
708	Male Tee, ½ FNPT x 8 MJIC x 8 MJIC
709	Cap, 8 FJIC

**Service Notes:**

1. Was Hex Head Screw, M10-5 x 25mm prior to November 1, 2020.
2. Was Flat Washer, 10mm prior to November 1, 2020.

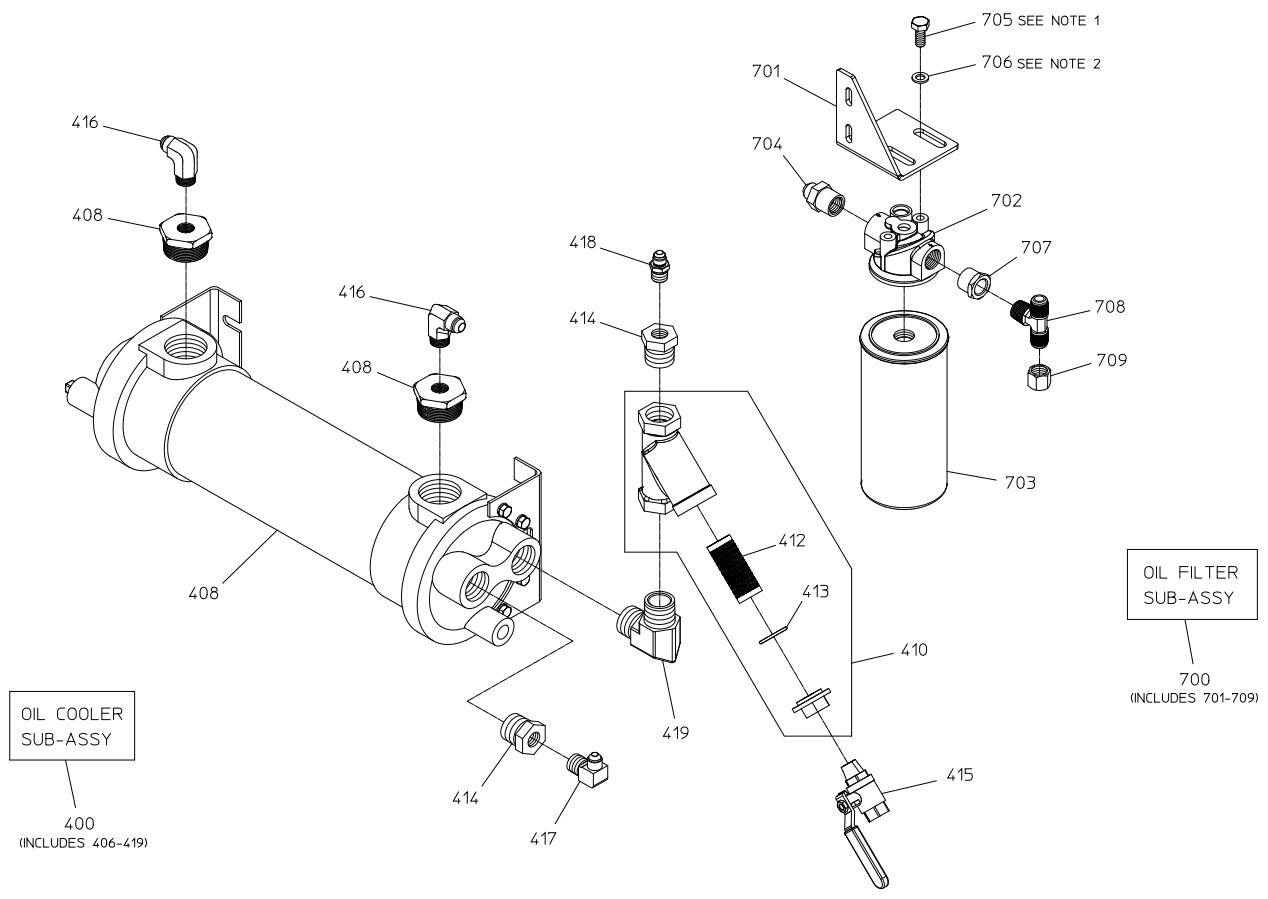

**OIL COOLER AND OIL FILTER  
IN-LINE WATER STRAINER  
COMPONENTS**

**Oil Cooler and Oil Filter  
In-Line Strainer – Water Lines**

REF NO.	DESCRIPTION
45	90 Degree Female Elbow, 3/8 FNPT
46	Pipe Nipple, ¼ NPT x 7/8 in.
50	Reducing Bushing, ¼ MNPT x 3/8 FNPT
52	Tee, 3/8 NPT

REF NO.	DESCRIPTION
53	Hydraulic Hose, 3/8 in. x 48 in.
54	90 Degree Street Elbow, 3/8 NPT
400	Oil Cooler Subassembly



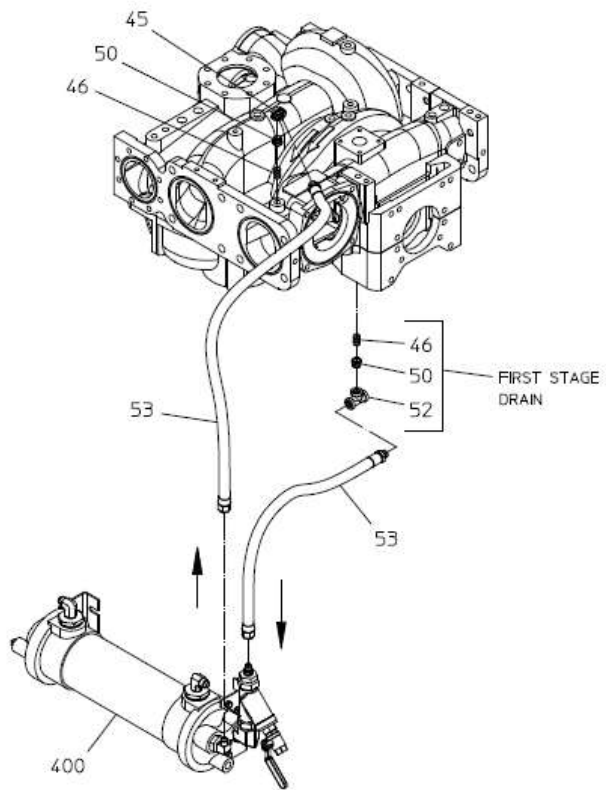

CM MODELS

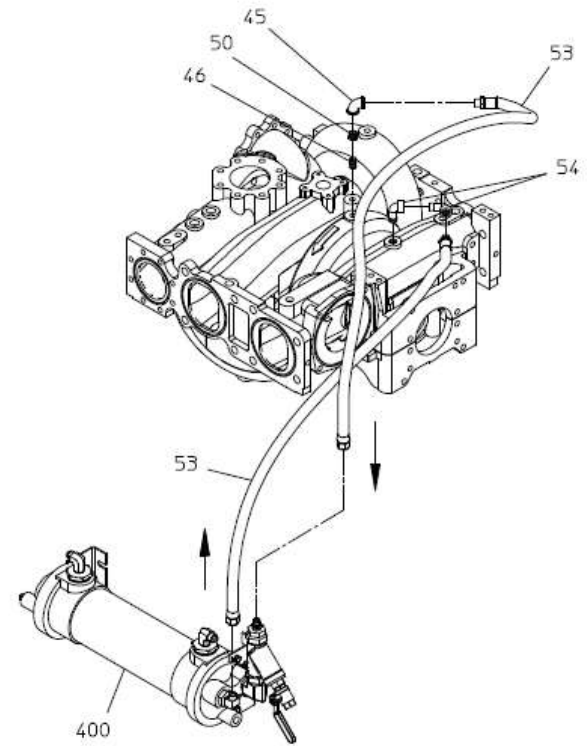

CS MODELS

OIL COOLER AND FILTER  
IN-LINE STRAINER  
WATER LINES

SEE PAGE 37 FOR HOSES NOT SHOWN

**Oil Cooler and Oil Filter  
Panel Mounted Water Strainer - Mounting**

REF NO.	DESCRIPTION
14	Lock Washer, 5/16 in.
18	Plain Washer, 5/16 in.
36	Oil Cooler Saddle Bracket
37	Hex Head Screw, ½-13 x 2 in.
38	Hex Head Screw, 5/16-24 x 1 in.
39	Hex Head Screw, 7/16-20 x 1-1/4 in.
40	Plain Washer, 7/16 in.

REF NO.	DESCRIPTION
41	Lock Washer, 7/16 in.
42	Hex Nut, 7/16-20
58	Hex Nut, 5/16-24
400	Oil Cooler Subassembly
700	Oil Filter Subassembly

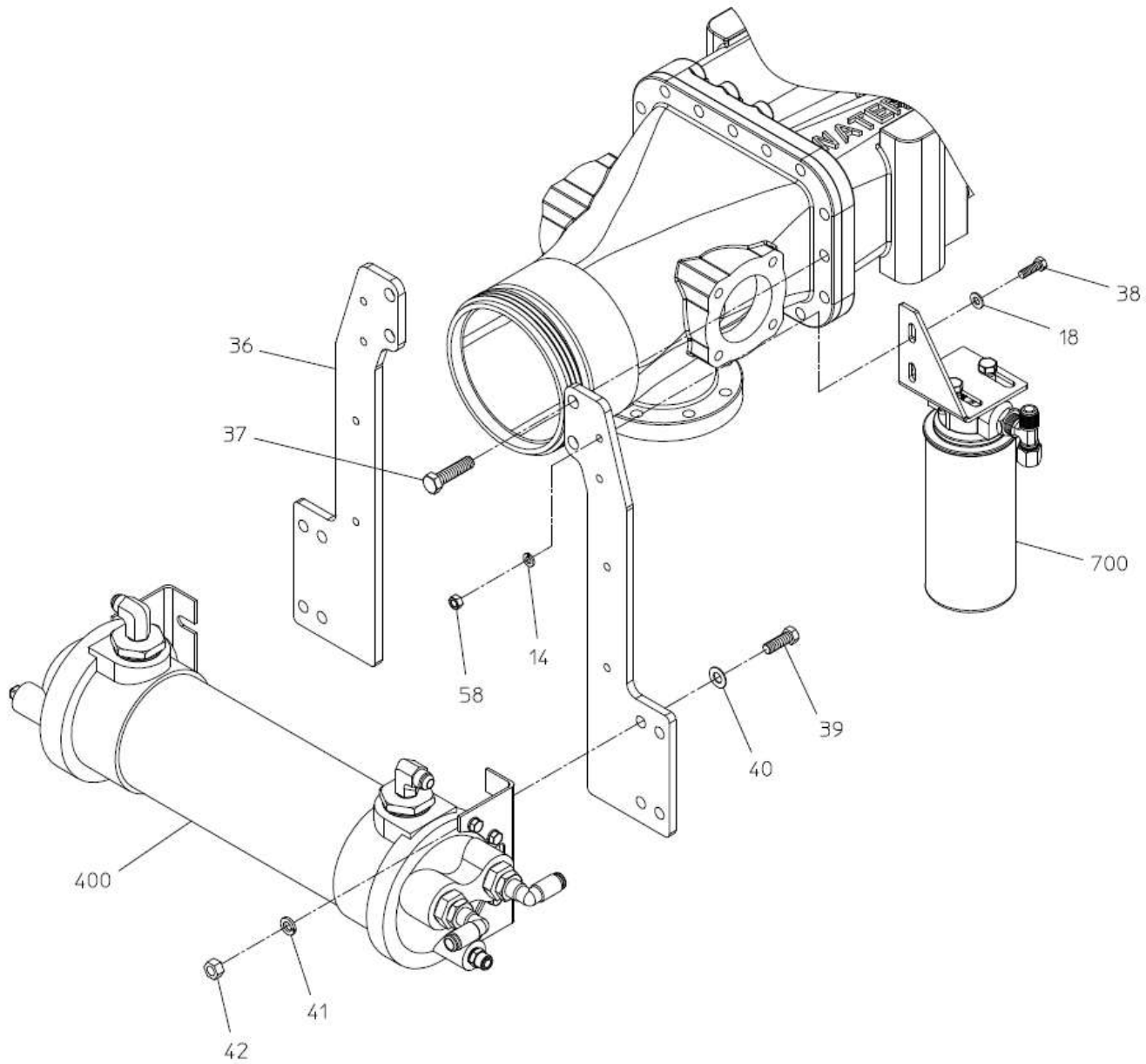

OIL COOLER AND OIL FILTER  
PANEL MOUNTED WATER STRAINER MOUNTING

**Oil Cooler and Oil Filter**  
**Panel Mounted Water Strainer - Components**

REF NO.	DESCRIPTION
400	Oil Cooler Subassembly (Includes 401-420)
406	Large Iron Cooler (Includes Brackets and Pipe Plugs)
408	Reducing Bushing, 1-1/2 NPT x ½ NPT
414	Reducing Bushing, 1 MNPT x ½ FNPT
416	90 Degree Elbow, 8 MJIC x ½ MNPT
417	90 Degree Elbow, ½ MNPT x ½ AB
420	Straight Adapter, 3/8 MNPT x 3/8 AB
450	Strainer Subassembly (Includes 451-456)
451	Panel Mounted Strainer, 20 Mesh
452	90 Degree Elbow, ½ MNPT x ½ AB
453	Reducing Bushing, 1 MNPT x ½ FNPT
454	Headless Plug, 1 NPT
455	Headless Plug, ¼ NPT
456	Straight Adapter, ½ MNPT x ½ AB

REF NO.	DESCRIPTION
700	Oil Filter Subassembly (Includes 701-709)
701	Filter Bracket
702	Large Filter Head
703	Oil Filter, WD962
704	Straight Adapter, 8 MJIC x ¾ MNPT
705	Hex Head Screw, M10-.5 x 25mm
706	Flat Washer, 10mm
707	Reducing Bushing, ¾ MNPT x ½ FNPT
708	Male Tee, ½ FNPT x 8 MJIC x 8 MJIC
709	Cap, 8 FJIC

OIL COOLER  
SUB-ASSY

400  
(INCLUDES 406-420)

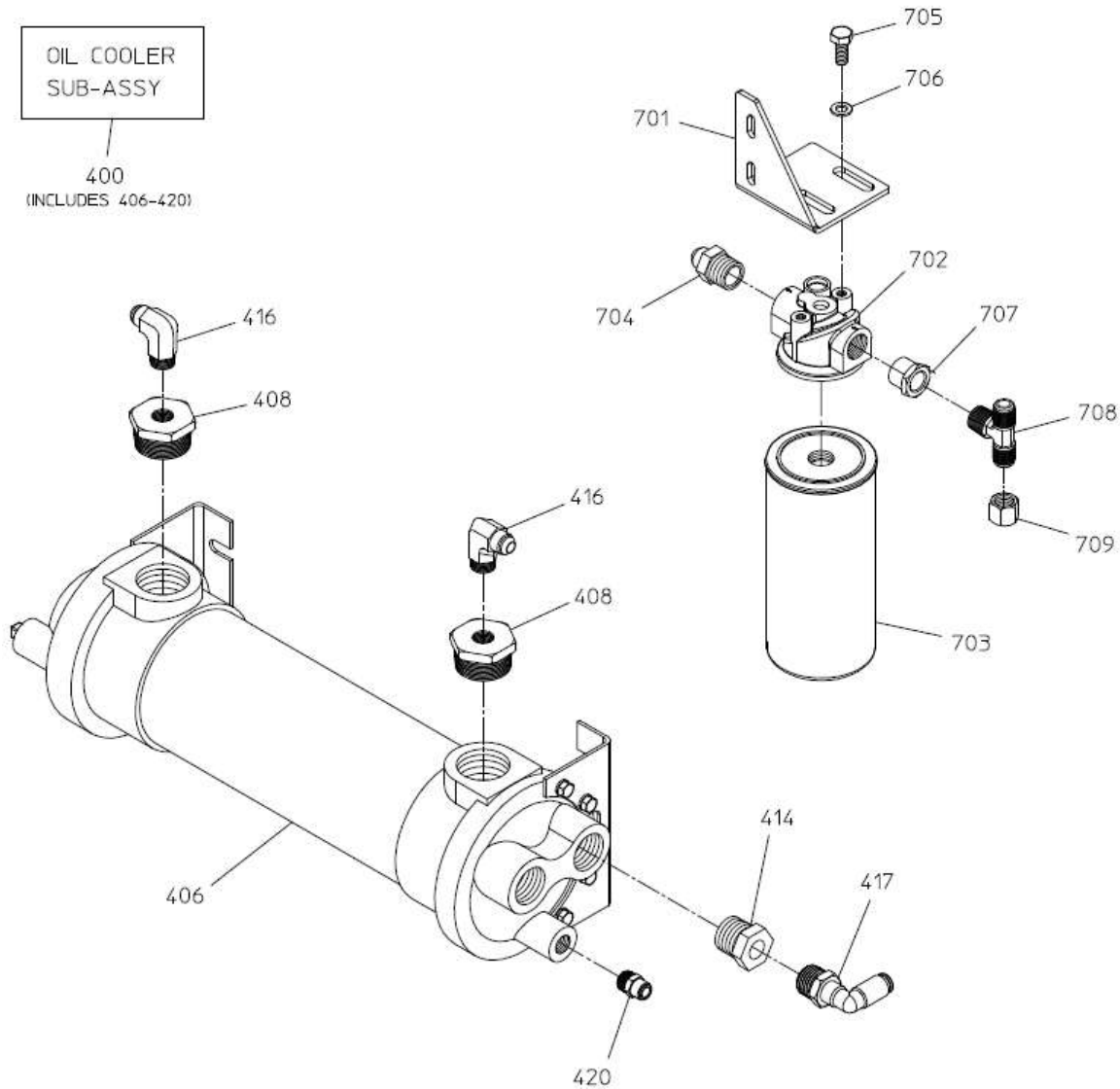

OIL FILTER  
SUB-ASSY

700  
(INCLUDES 701-709)

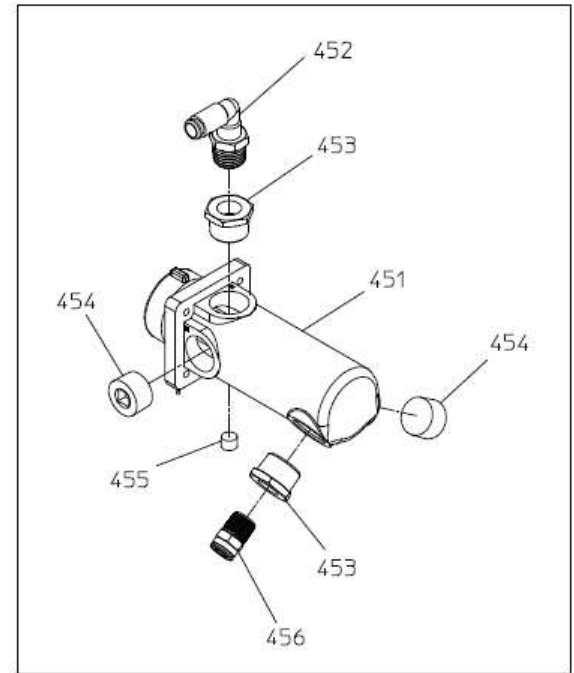

OIL COOLER AND OIL FILTER  
PANEL MOUNTED WATER STRAINER  
COMPONENTS

**Oil Cooler and Oil Filter  
Panel Mounted Water Strainer – Water Lines**

REF NO.	DESCRIPTION
55	90 Degree Elbow, ¼ MNPT x ½ AB
77	Red Air Brake Tube, ½ in. (Cut to Length)

REF NO.	DESCRIPTION
400	Oil Cooler Subassembly
450	Strainer Subassembly

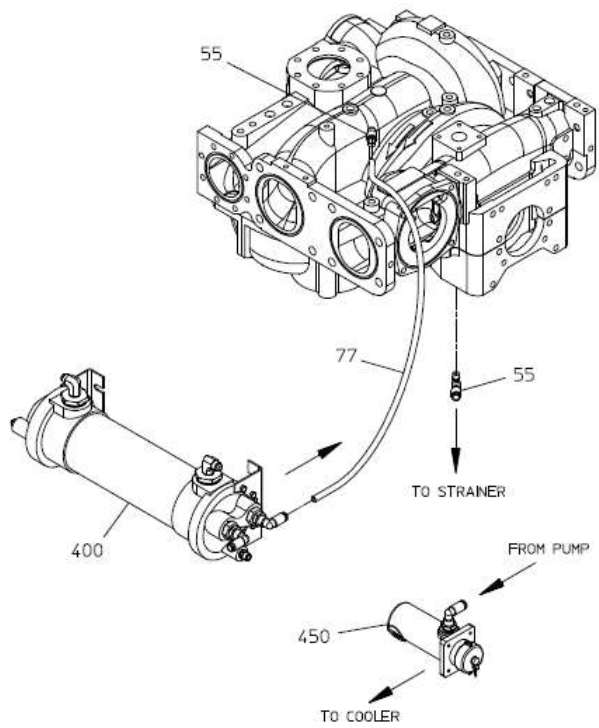

CM MODELS

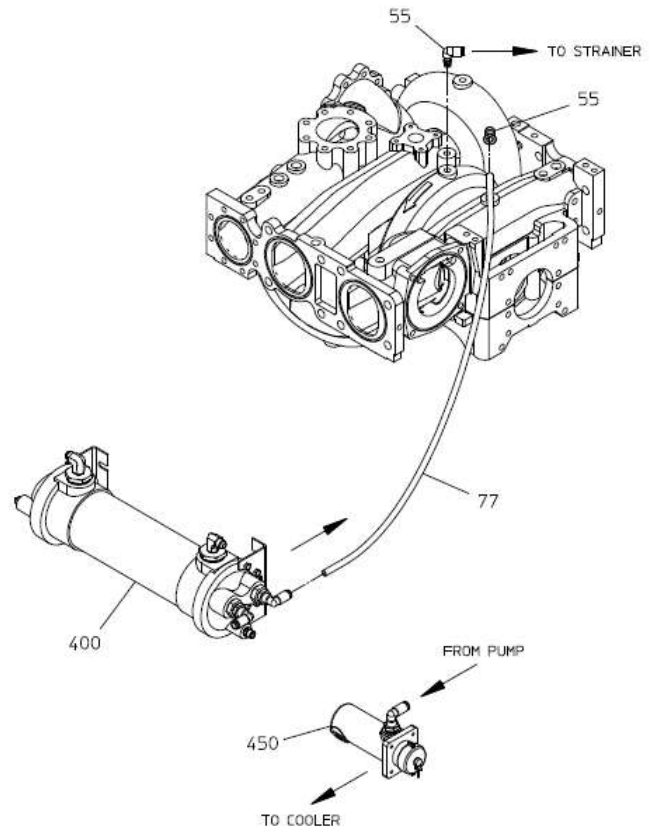

CS MODELS

OIL COOLER AND OIL FILTER  
PANEL MOUNTED STRAINER  
WATER LINES  
 SEE PAGE 39 FOR HOSES NOT SHOWN

**Schematic – Air Circuit**  
**Non-High Rise Configuration**

REF NO.	DESCRIPTION
76	Black Air Brake Tube, ¼ in. (Cut to Length)
201	90 Degree Air Inlet, 2-1/2 in.
228	Red Air Brake Tube, ¼ in. (Cut to Length)
229	Blue Air Brake Tube, ¼ in. (Cut to Length)

REF NO.	DESCRIPTION
230	Green Air Brake Tube, ¼ in. (Cut to Length)
600	Separator Subassembly
900	PMC Subassembly



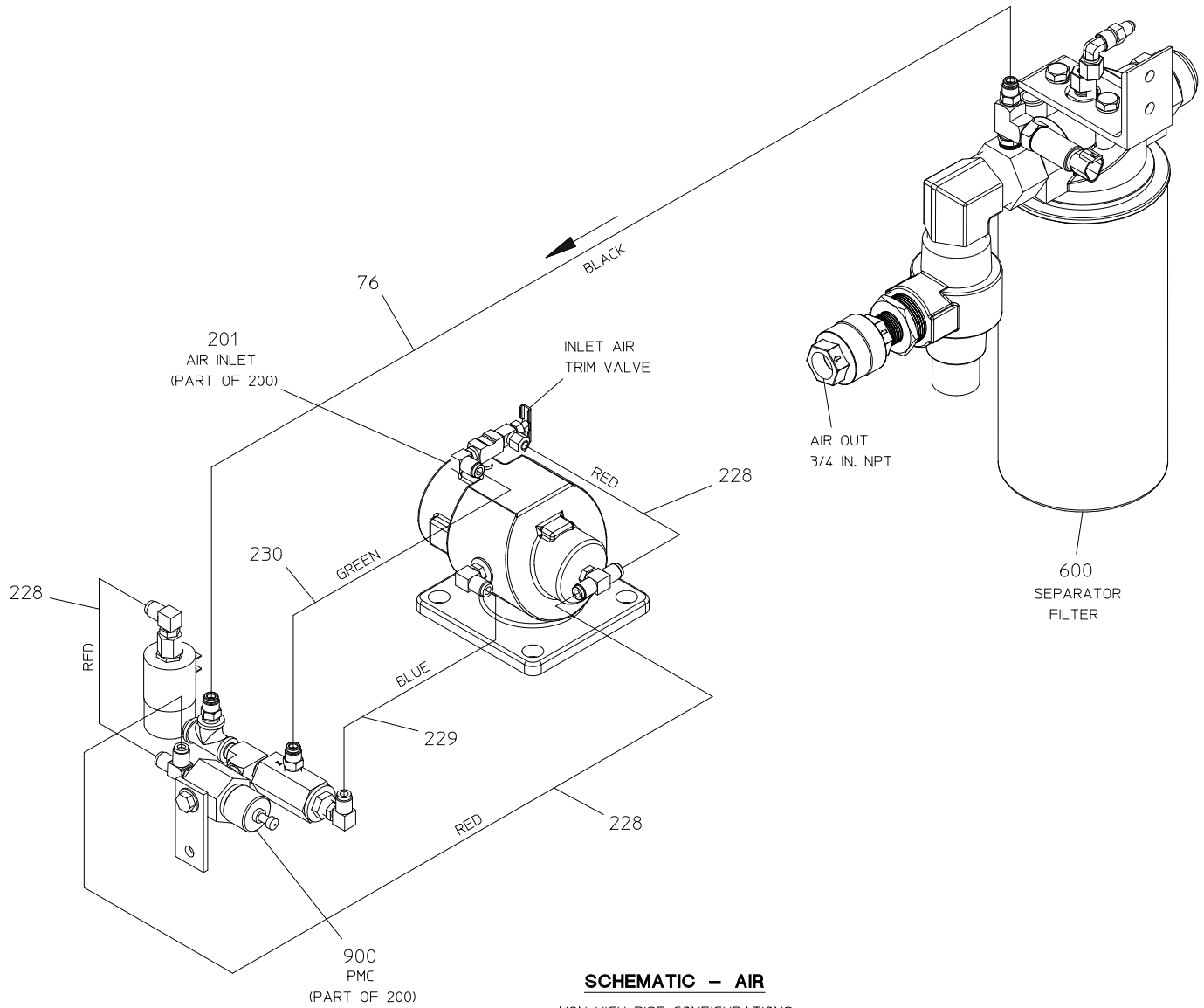

**SCHEMATIC - AIR**  
NON-HIGH RISE CONFIGURATIONS

## Schematic – Air Circuit High Rise Configuration

REF NO.	DESCRIPTION
47	Black Air Brake Tube, ¼ in. (Cut to Length)
48	Red Air Brake Tube, ¼ in. (Cut to Length)
49	Yellow Air Brake Tube, ¼ in. (Cut to Length)
76	Black Air Brake Tube, ¼ in. (Cut to Length)
201	90 Degree Air Inlet, 2-1/2 in.
228	Red Air Brake Tube, ¼ in. (Cut to Length)
229	Blue Air Brake Tube, ¼ in. (Cut to Length)

REF NO.	DESCRIPTION
230	Green Air Brake Tube, ¼ in. (Cut to Length)
240	Black Air Brake Tube, ¼ in. (Cut to Length)
300	Auto-Sync Subassembly
600	Separator Subassembly
900	PMC Subassembly

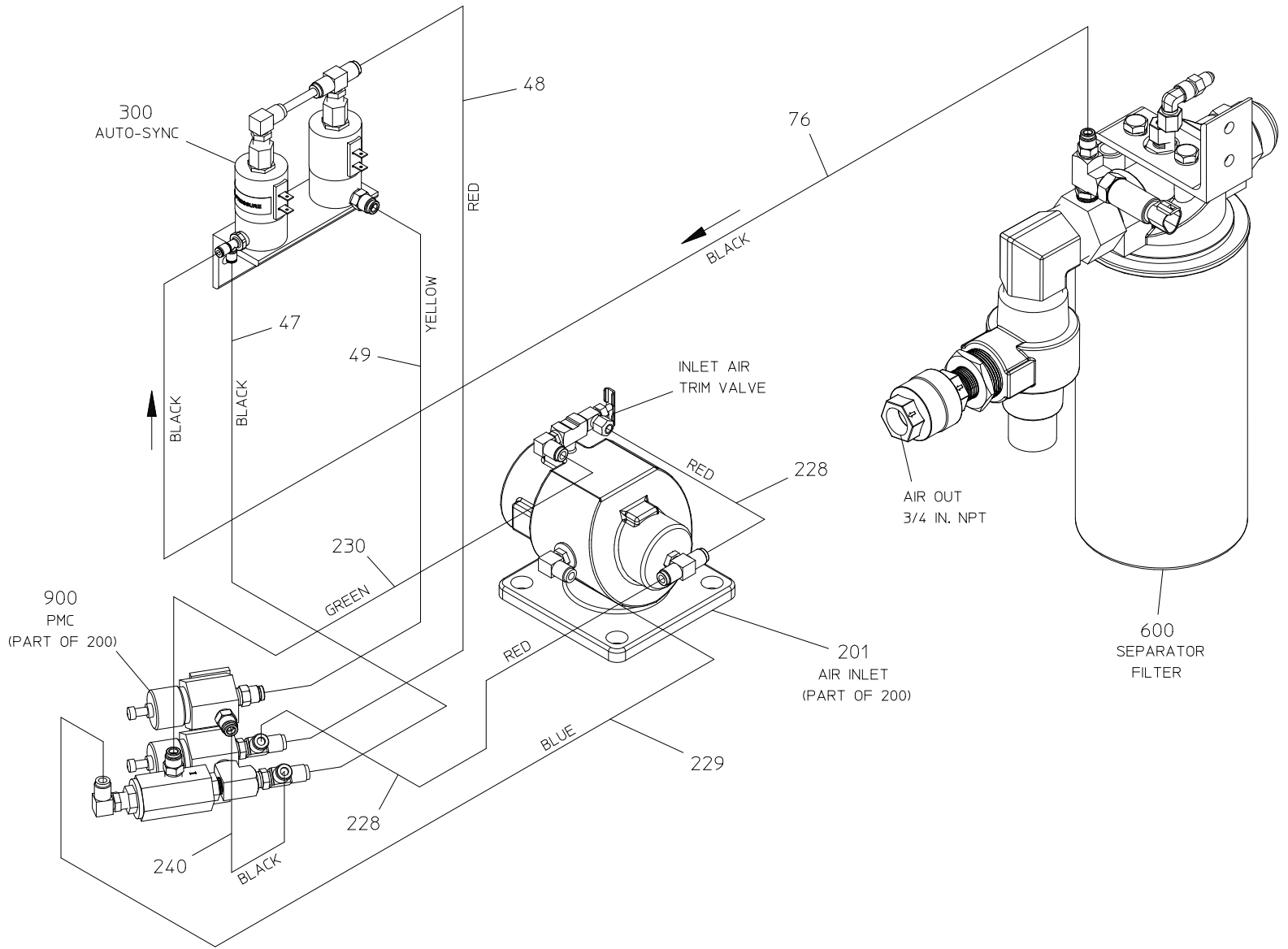

**SCHEMATIC - AIR**  
HIGH RISE CONFIGURATIONS

## Schematic – Hydraulic In-Line Strainer

REF NO.	DESCRIPTION
43	Hydraulic Hose, 8 FJIC x 50 in.
44	Hydraulic Hose, 8 FJIC x 23 in.
53	Hydraulic Hose, 3/8 x 48 in.
200	Compressor Subassembly

REF NO.	DESCRIPTION
400	Oil Cooler Subassembly
500	Sump Subassembly
600	Separator Subassembly
700	Oil Filter Subassembly

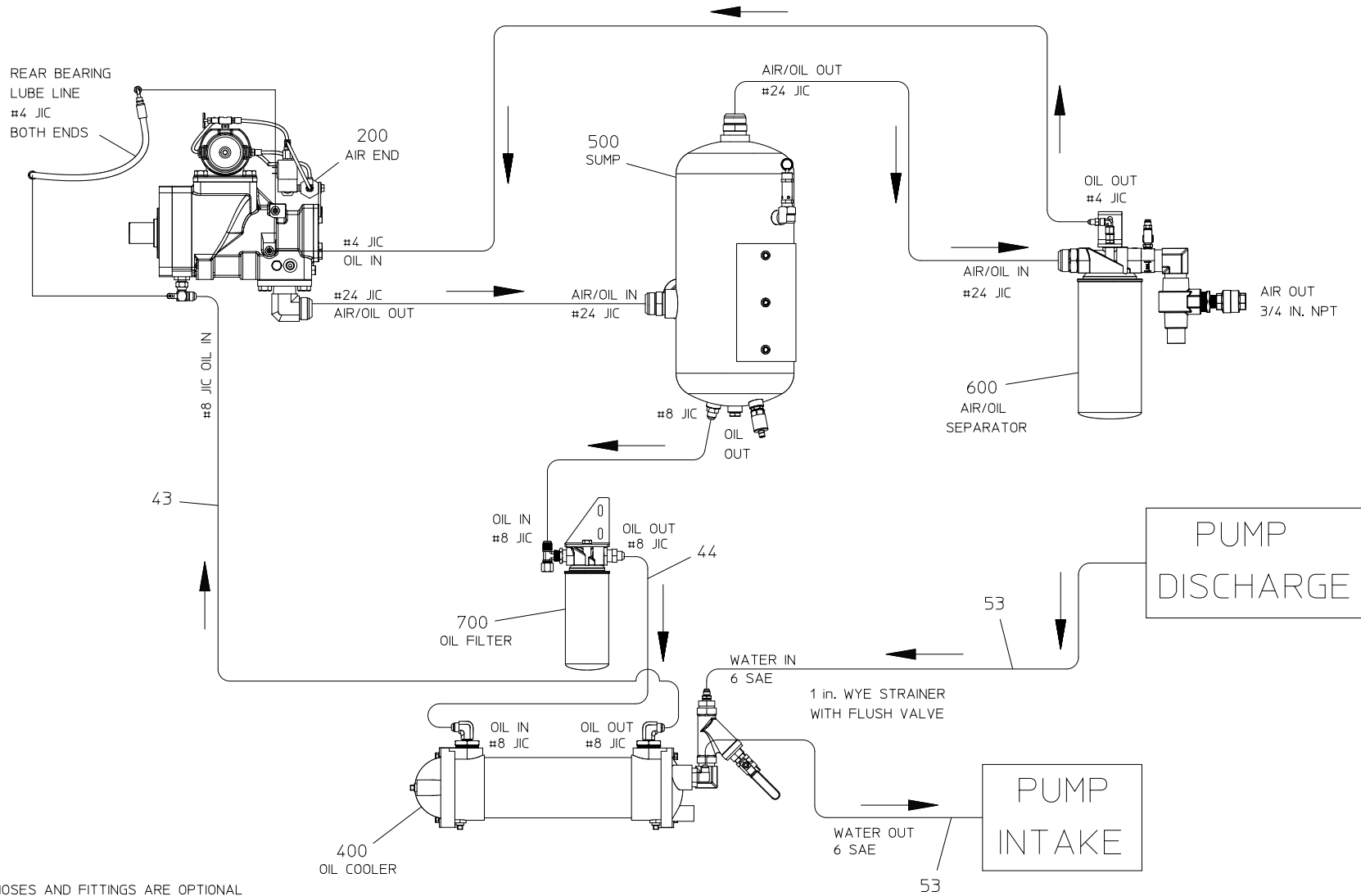

NOTE: HOSES AND FITTINGS ARE OPTIONAL FROM WATEROUS. MAY HAVE BEEN FURNISHED BY OEM. SEE HOSE AND FITTINGS SERVICE PARTS LIST SPL83368.

**SCHMATIC – HYDRAULIC**  
IN-LINE STRAINER

## Schematic – Hydraulic Panel Mounted Strainer

REF NO.	DESCRIPTION
43	Hydraulic Hose, 8 FJIC x 50 in.
44	Hydraulic Hose, 8 FJIC x 23 in.
77	Red Air Brake Tube, ¼ in. (Cut to Length)
200	Compressor Subassembly
400	Oil Cooler Subassembly

REF NO.	DESCRIPTION
450	Strainer Subassembly
500	Sump Subassembly
600	Separator Subassembly
700	Oil Filter Subassembly

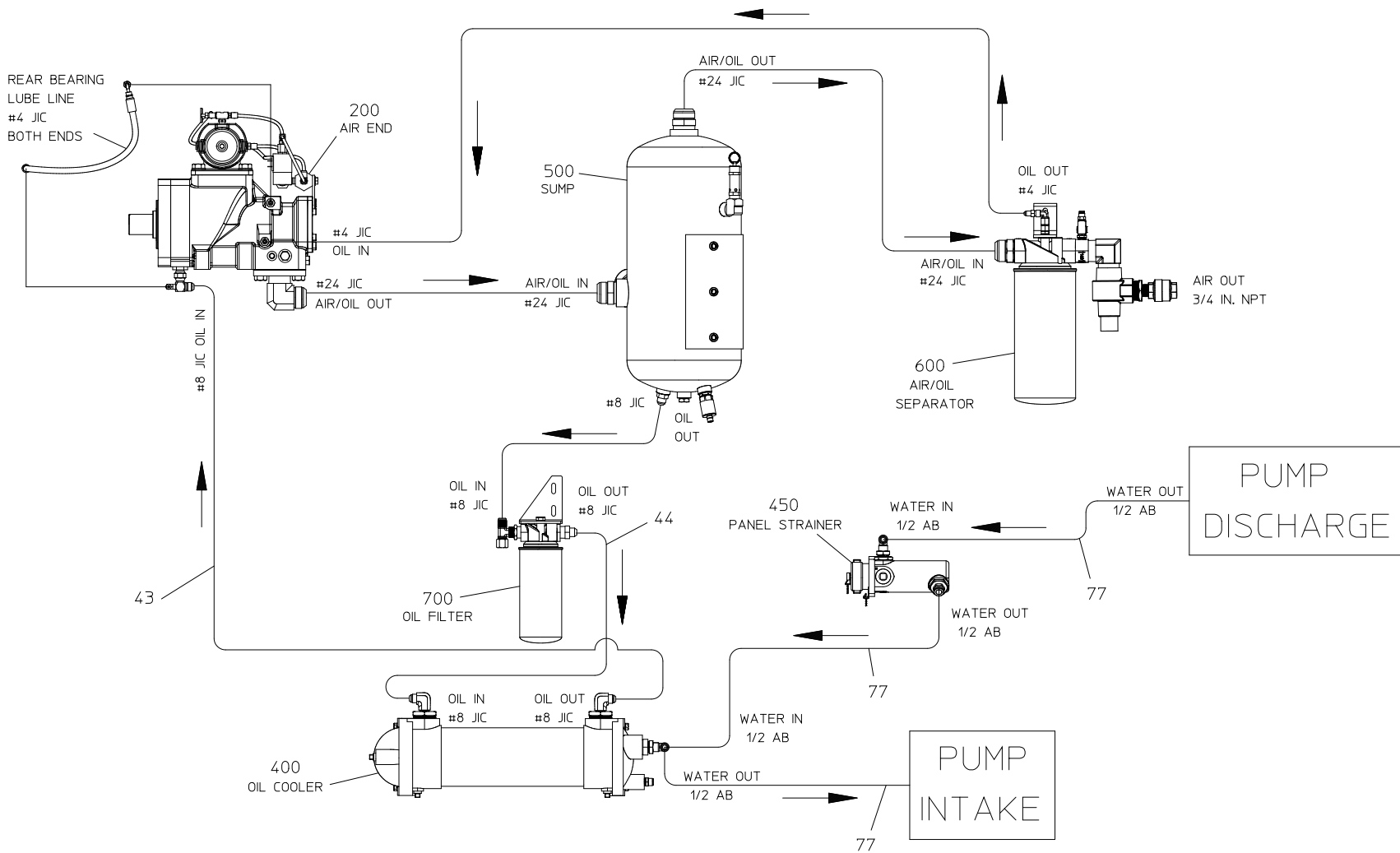

NOTE: HOSES AND FITTINGS ARE OPTIONAL FROM WATEROUS, MAY HAVE BEEN FURNISHED BY OEM. SEE HOSE AND FITTINGS SERVICE PARTS LIST SPL83368.

**SCHMATIC - HYDRAULIC**  
PANEL MOUNTED STRAINER