

C21 Series Transmission Service Parts List

Index:

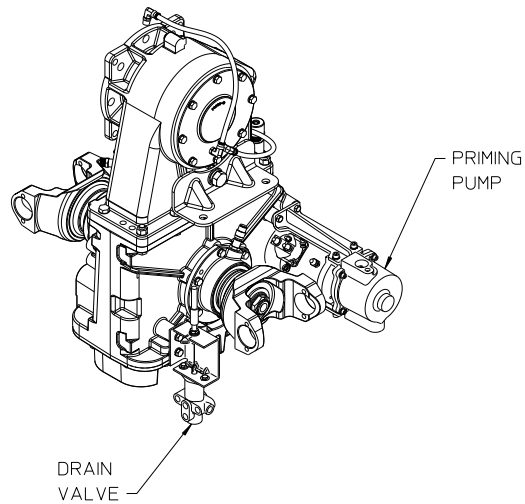

**VIEWED FROM
INPUT SHAFT SIDE**

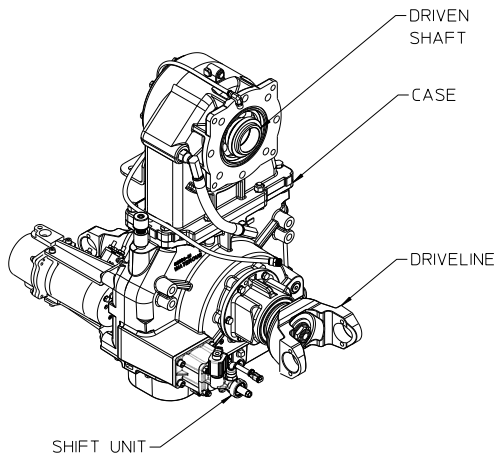

VIEWED FROM

	Components			See Page
	Pump Mounting On Transmission	Output Connection Opposite Pump		
Driven Shaft	Front (Input Shaft Side)	Rear (Output Shaft Side)	None (Blank)	2, 3
			Hydraulic Pump (SAE Class C 4-Bolt Hydraulic Flange)	4, 5
	Rear (Output Shaft Side)	Front (Input Shaft Side)	None (Blank)	6, 7
			Hydraulic Pump (SAE Class C 4-Bolt Hydraulic Flange)	8, 9
Driveline	Input and Output Shafts		Exploded View	10, 11
			Cross-Section View	12, 13
	Input Shaft Only		Exploded View	14, 15
			Cross-Section View	16, 17
Shift Unit	See Shift Unit Service Parts List			-
Case	Viewed from Input Side		18, 19	
			Viewed from Output Side	
	Cap Variations	Sealant Application & Hardware	Front Facing, 1.77 Ratio	22, 23
			Front Facing, 1.95 Ratio	24, 25
			Rear Facing, 1.77 Ratio	26, 27
		Cooling Lines	Front Facing, 1.77 and 1.95 Ratio	28, 29
			Rear Facing, 1.77 Ratio	30, 31
Optional Accessories	Transmission Mounted Drain Valve		See Drain Valve Service List	
	Model VPO Priming Pump		See Priming Pump Service Parts List	

Driven Shaft – Pump Mounting: Front (Input Shaft Side)
Connection Opposite Pump: None (Blank)

REF. NO.	DESCRIPTION
T8	Hex Hd Screw, 3/8-16 x 1 in.
T9	Lock Washer, 3/8 in.
T19	Oil Seal, 3 x 3-3/4 in.
T24	Single Row Ball Bearing
T25	Single Row Ball Bearing
T26	Driven Sprocket
T29	Bearing Spacer, .590 in. Long
T31	Bearing Cover
T32	Bearing Lock Nut Washer (W10)
T33	Bearing Lock Nut (N10)

REF. NO.	DESCRIPTION
T40	Wave Spring, 110 mm
T65	Transmission Cap, Front Facing
T95	Bearing Spacer, 1.405 in. Long
T128	Oil Seal Sleeve
T129	O-ring, 5-5/8 x 5-7/8 in.
T130	O-ring, 6-3/4 x 7-1/8 in.
T133	O-ring, 4 x 4-1/4 in.
T141	O-ring and Gasket Repair Kit

Hardware Torque Specifications

Screw Size	Torque Specification
5/16-18 UNC	17 lb-ft
3/8-16 UNC	31 lb-ft
1/2-13 UNC	75 lb-ft
1/2-20 UNF	85 lb-ft
5/8-11 UNC	150 lb-ft

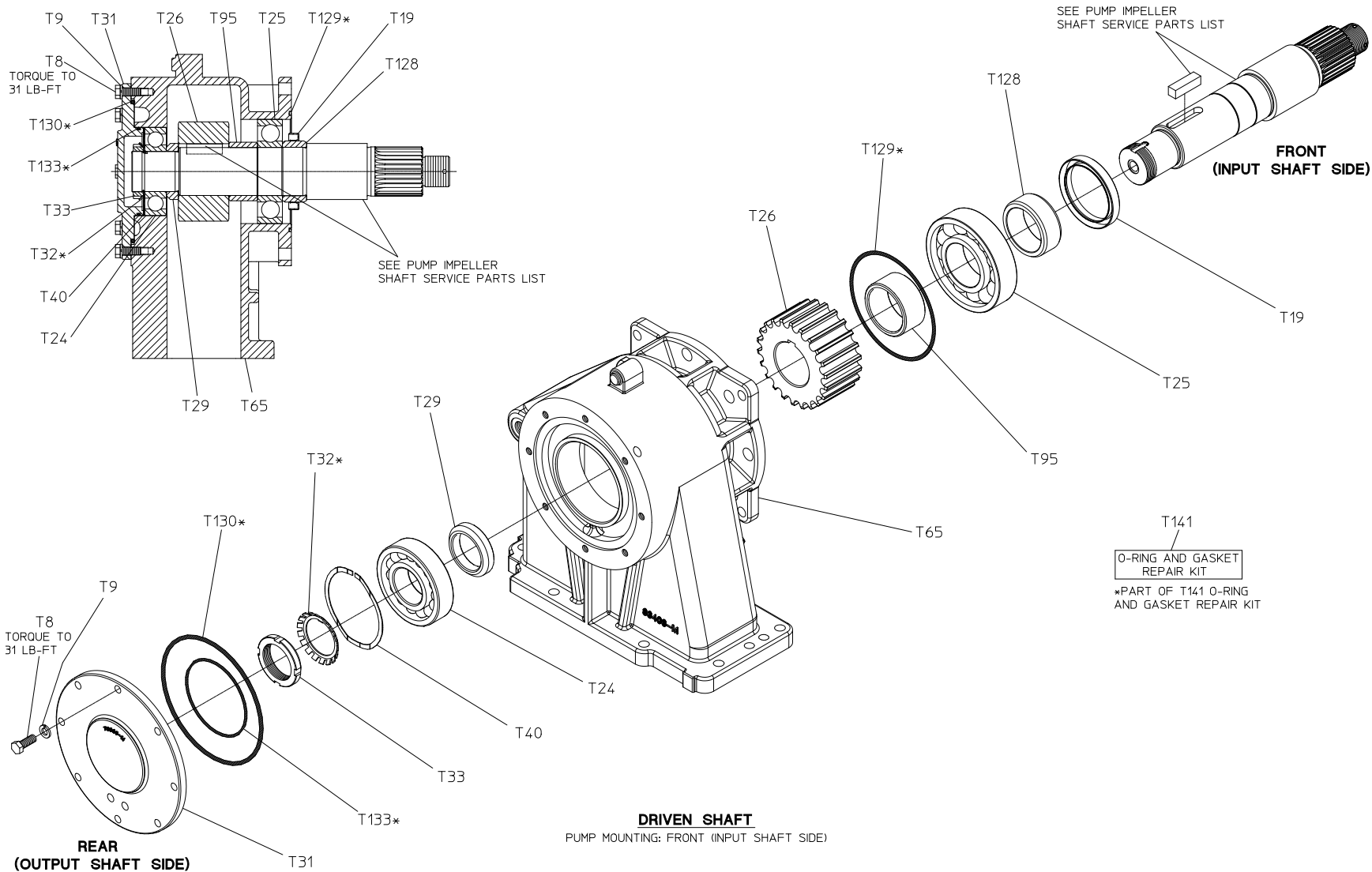

Driven Shaft – Pump Mounting: Front (Input Shaft Side)
Connection Opposite Pump: Hydraulic Pump

REF. NO.	DESCRIPTION
T19	Oil Seal, 3 x 3-3/4 in.
T21	Skt Hd Screw, 3/8-16 x 2-1/4
T22	Hydraulic Adapter
T23	Oil Seal, 1-25/32 x 2-5/8
T24	Single Row Ball Bearing
T25	Single Row Ball Bearing
T26	Driven Sprocket
T29	Bearing Spacer, .590 in. Long
T32	Bearing Lock Nut Washer (W10)
T33	Bearing Lock Nut (N10)

REF. NO.	DESCRIPTION
T40	Wave Spring, 110 mm
T65	Transmission Cap, Front Facing
T95	Bearing Spacer, 1.405 in. Long
T128	Oil Seal Sleeve
T129	O-ring, 5-5/8 x 5-7/8 in.
T130	O-ring, 6-3/4 x 7-1/8 in.
T133	O-ring, 4 x 4-1/4 in.
T141	O-ring and Gasket Repair Kit

Hardware Torque Specifications

Screw Size	Torque Specification
5/16-18 UNC	17 lb-ft
3/8-16 UNC	31 lb-ft
1/2-13 UNC	75 lb-ft
1/2-20 UNF	85 lb-ft
5/8-11 UNC	150 lb-ft

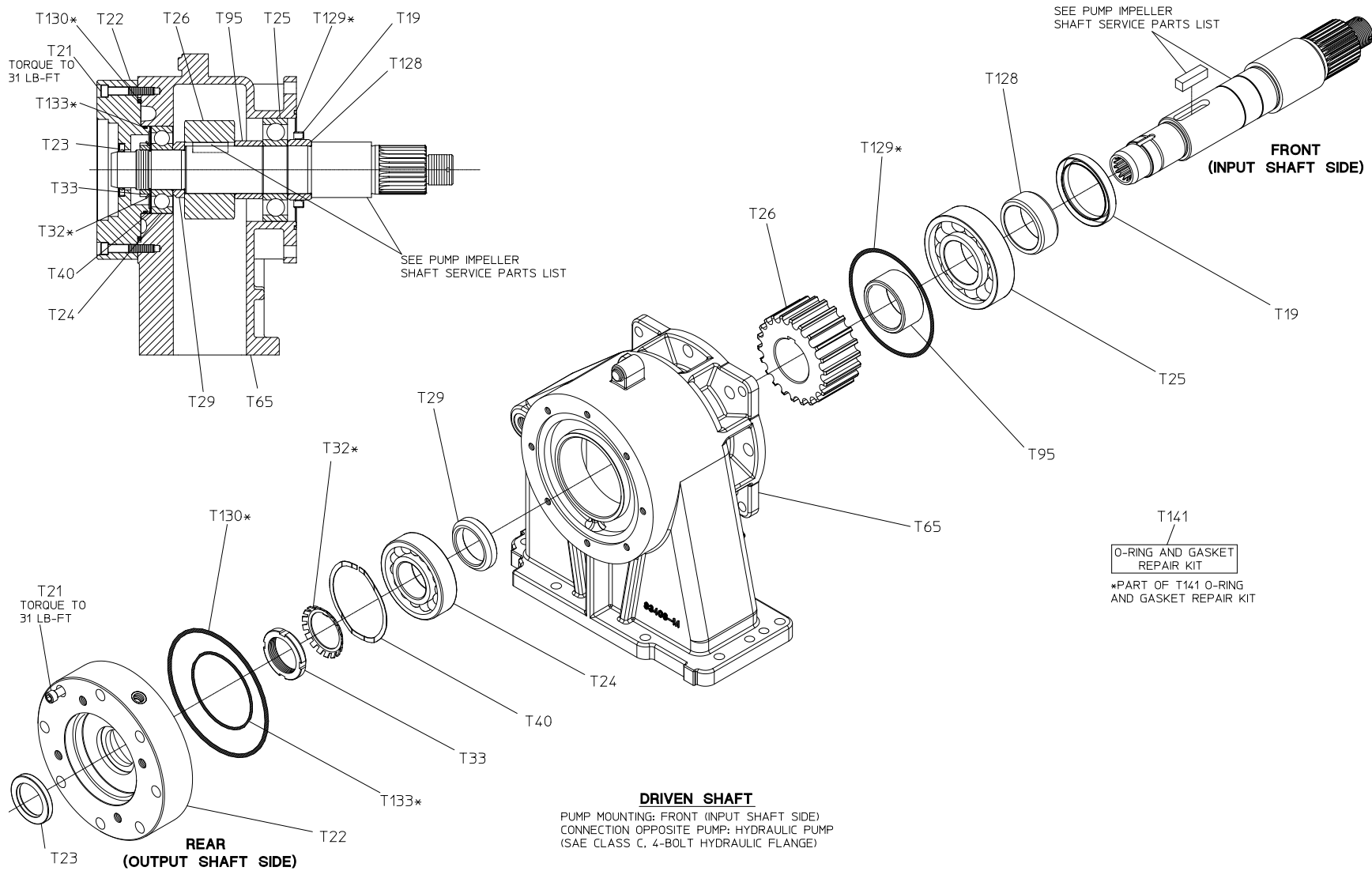

Driven Shaft – Pump Mounting: Rear (Output Shaft Side)
Connection Opposite Pump: None (Blank)

REF. NO.	DESCRIPTION
T8	Hex Hd Screw, 3/8-16 x 1 in.
T9	Lock Washer, 3/8 in.
T19	Oil Seal, 3 x 3-3/4 in.
T24	Single Row Ball Bearing
T25	Single Row Ball Bearing
T26	Driven Sprocket
T29	Bearing Spacer, .590 in. Long
T31	Bearing Cover
T32	Bearing Lock Nut Washer (W10)
T33	Bearing Lock Nut (N10)

REF. NO.	DESCRIPTION
T40	Wave Spring, 110 mm
T65	Transmission Cap, Rear Facing
T95	Bearing Spacer, 1.405 in. Long
T128	Oil Seal Sleeve
T129	O-ring, 5-5/8 x 5-7/8 in.
T130	O-ring, 6-3/4 x 7-1/8 in.
T133	O-ring, 4 x 4-1/4 in.
T141	O-ring and Gasket Repair Kit

Hardware Torque Specifications

Screw Size	Torque Specification
5/16-18 UNC	17 lb-ft
3/8-16 UNC	31 lb-ft
1/2-13 UNC	75 lb-ft
1/2-20 UNF	85 lb-ft
5/8-11 UNC	150 lb-ft

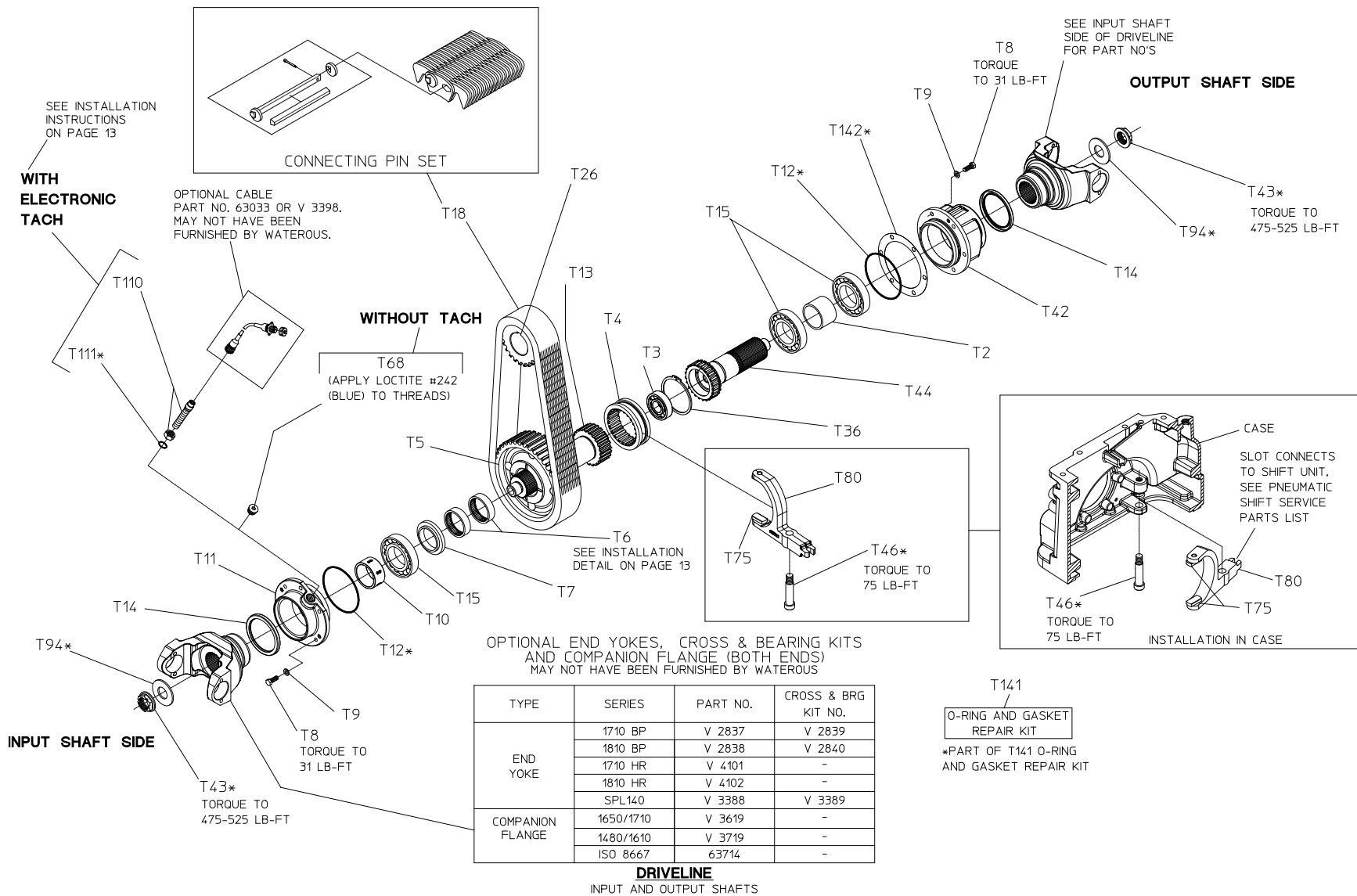

Driven Shaft – Pump Mounting: Rear (Output Shaft Side)
Connection Opposite Pump: Hydraulic Pump

REF. NO.	DESCRIPTION
T19	Oil Seal, 3 x 3-3/4 in.
T21	Skt Hd Screw, 3/8-16 x 2-1/4
T22	Hydraulic Adapter
T23	Oil Seal, 1-25/32 x 2-5/8
T24	Single Row Ball Bearing
T25	Single Row Ball Bearing
T26	Driven Sprocket
T29	Bearing Spacer, .590 in. Long
T32	Bearing Lock Nut Washer (W10)
T33	Bearing Lock Nut (N10)

REF. NO.	DESCRIPTION
T40	Wave Spring, 110 mm
T65	Transmission Cap, Rear Facing
T95	Bearing Spacer, 1.405 in. Long
T128	Oil Seal Sleeve
T129	O-ring, 5-5/8 x 5-7/8 in.
T130	O-ring, 6-3/4 x 7-1/8 in.
T133	O-ring, 4 x 4-1/4 in.
T141	O-ring and Gasket Repair Kit

Hardware Torque Specifications

Screw Size	Torque Specification
5/16-18 UNC	17 lb-ft
3/8-16 UNC	31 lb-ft
1/2-13 UNC	75 lb-ft
1/2-20 UNF	85 lb-ft
5/8-11 UNC	150 lb-ft

Drive Line – Input and Output Shafts
(Exploded View)

REF. NO.	DESCRIPTION
T2	Coupling Shaft Spacer
T3	Single Row Ball Bearing
T4	Shift Collar
T5	Drive Sprocket
T6	Needle Bearing
T7	Thrust Washer
T8	Hex Hd Screw, 3/8-16 x 1 in.
T9	Lock Washer, 3/8 in.
T10	Tachometer Pulse Generator
T11	Drive Shaft Housing
T12	O-ring, 4-3/4 x 5 in.
T13	Drive Shaft
T14	Oil Seal, 3-1/2 x 4-3/8 in.
T15	Single Row Ball Bearing
T18	Chain
T26	Driven Sprocket
T36	Retaining Ring
T42	Coupling Shaft Housing

REF. NO.	DESCRIPTION
T43	Self-Locking Nut, 1-1/4-18 in.
T44	Coupling Shaft (Includes T36)
T46	Shoulder Screw, 3/4 x 2-1/2
T62	Chain Connecting Pin Set
T68	Set Screw, 5/8-18 x 5/8 in.
T75	Shift Shoe
T80	Shift Fork
T94	Plain Washer, 1-1/4 in.
T110	Magnetic Tachometer Pick-up
T111	O-ring, 5/8 x 3/4 in.
T141	O-ring and Gasket Repair Kit
T142	Aluminum Shim

Hardware Torque Specifications

Screw Size	Torque Specification
5/16-18 UNC	17 lb-ft
3/8-16 UNC	31 lb-ft
1/2-13 UNC	75 lb-ft
1/2-20 UNF	85 lb-ft
5/8-11 UNC	150 lb-ft

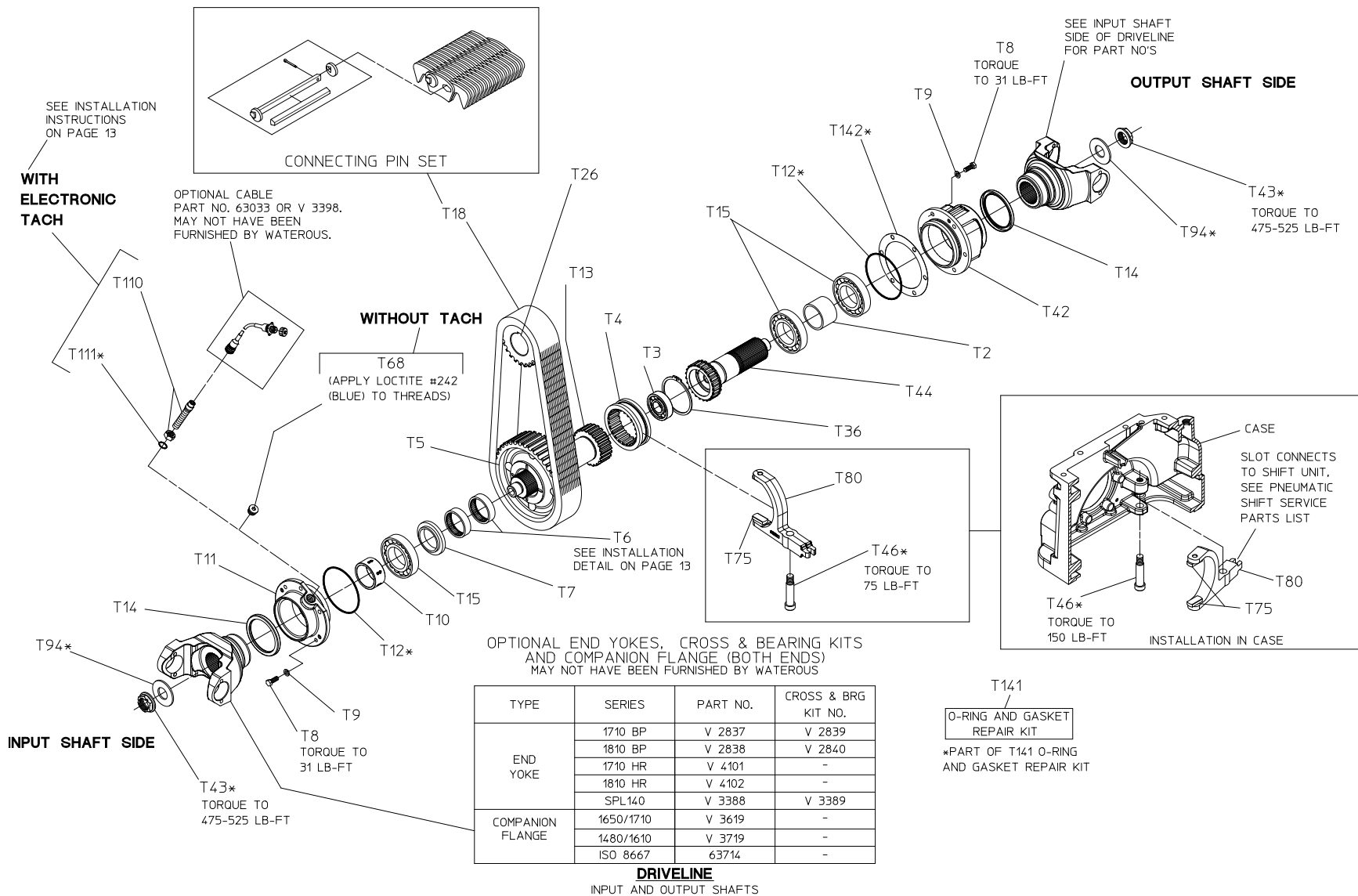

Drive Line – Input and Output Shafts
(Cross-Section View)

REF. NO.	DESCRIPTION
T2	Coupling Shaft Spacer
T3	Single Row Ball Bearing
T4	Shift Collar
T5	Drive Sprocket
T6	Needle Bearing
T7	Thrust Washer
T8	Hex Hd Screw, 3/8-16 x 1 in.
T9	Lock Washer, 3/8 in.
T10	Tachometer Pulse Generator
T11	Drive Shaft Housing
T12	O-ring, 4-3/4 x 5 in.
T13	Drive Shaft
T14	Oil Seal, 3-1/2 x 4-3/8 in.
T15	Single Row Ball Bearing
T18	Chain
T36	Retaining Ring

REF. NO.	DESCRIPTION
T42	Coupling Shaft Housing
T43	Self-Locking Nut, 1-1/4-18 in.
T44	Coupling Shaft (Includes T36)
T46	Shoulder Screw, 3/4 x 2-1/2
T68	Set Screw, 5/8-18 x 5/8 in.
T75	Shift Shoe
T80	Shift Fork
T94	Plain Washer, 1-1/4 in.
T110	Magnetic Tachometer Pick-up
T111	O-ring, 5/8 x 3/4 in.
T141	O-ring and Gasket Repair Kit
T142	Aluminum Shim

Hardware Torque Specifications

Screw Size	Torque Specification
5/16-18 UNC	17 lb-ft
3/8-16 UNC	31 lb-ft
1/2-13 UNC	75 lb-ft
1/2-20 UNF	85 lb-ft
5/8-11 UNC	150 lb-ft

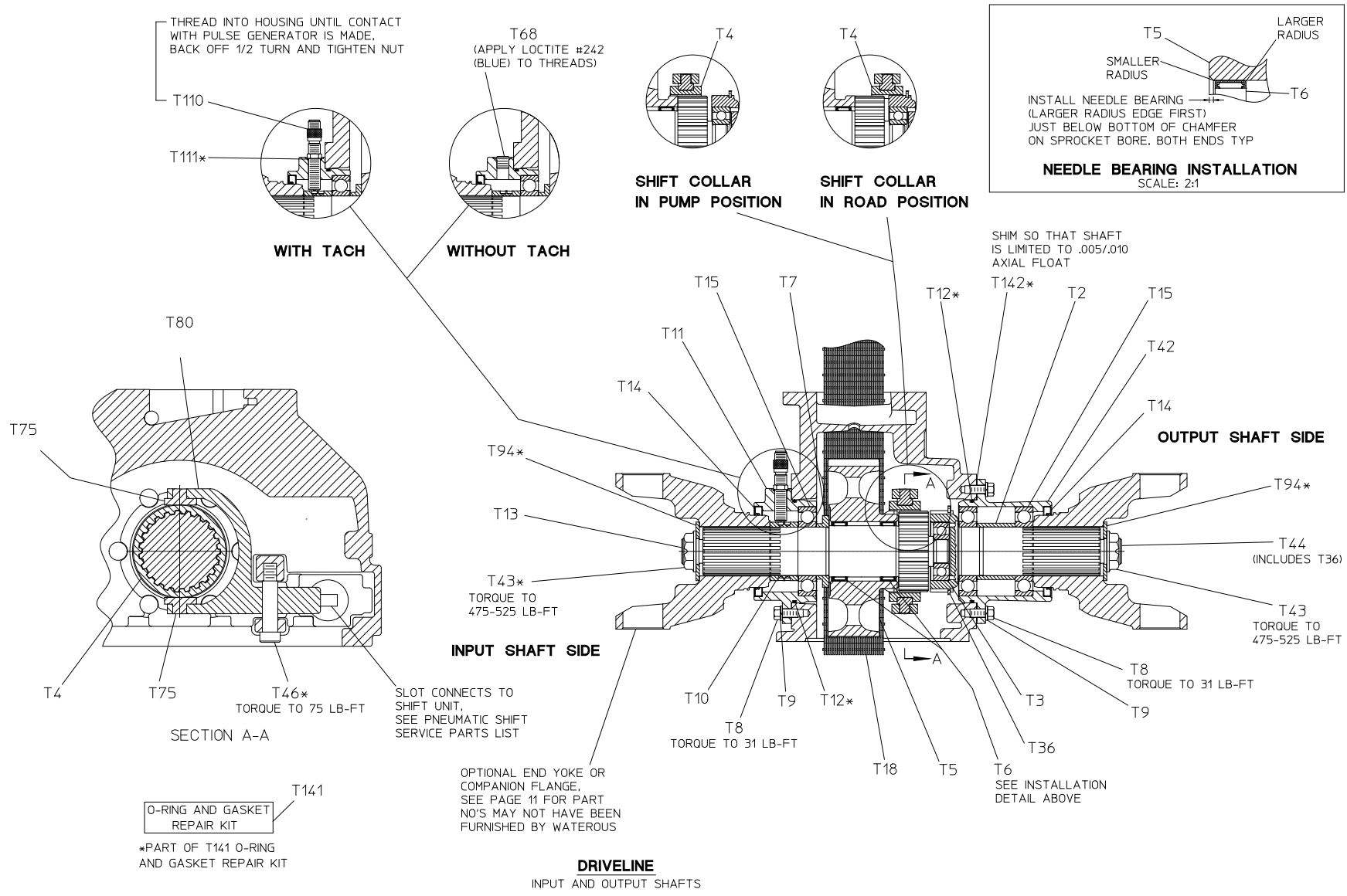

Driveline - Input Shaft Only

Exploded View

REF. NO.	DESCRIPTION
T3	Single Row Ball Bearing
T4	Shift Collar
T5	Drive Sprocket
T6	Needle Bearing
T7	Thrust Washer
T8	Hex Hd Screw, 3/8-16 x 1 in.
T9	Lock Washer, 3/8 in.
T10	Tachometer Pulse Generator
T11	Drive Shaft Housing
T12	O-ring, 4-3/4 x 5 in.
T13	Drive Shaft
T14	Oil Seal, 3-1/2 x 4-3/8 in.
T15	Single Row Ball Bearing
T18	Chain
T26	Driven Sprocket
T36	Retaining Ring
T41	Wave Spring, 72 mm

REF. NO.	DESCRIPTION
T42	Bearing Housing
T43	Self-Locking Nut, 1-1/4-18 in.
T57	Magnetic Drain Plug, 3/4-16
T68	Set Screw, 5/8-18 x 5/8 in.
T83	Chain Connecting Pin Set
T94	Plain Washer, 1-1/4 in.
T108	Spirol Pin, 1/16 x 1/4 or 1/16 x 5/16 in.
T141	Gasket and O-ring Repair Kit

Hardware Torque Specifications

Screw Size	Torque Specification
5/16-18 UNC	17 lb-ft
3/8-16 UNC	31 lb-ft
1/2-13 UNC	75 lb-ft
1/2-20 UNF	85 lb-ft
5/8-11 UNC	150 lb-ft

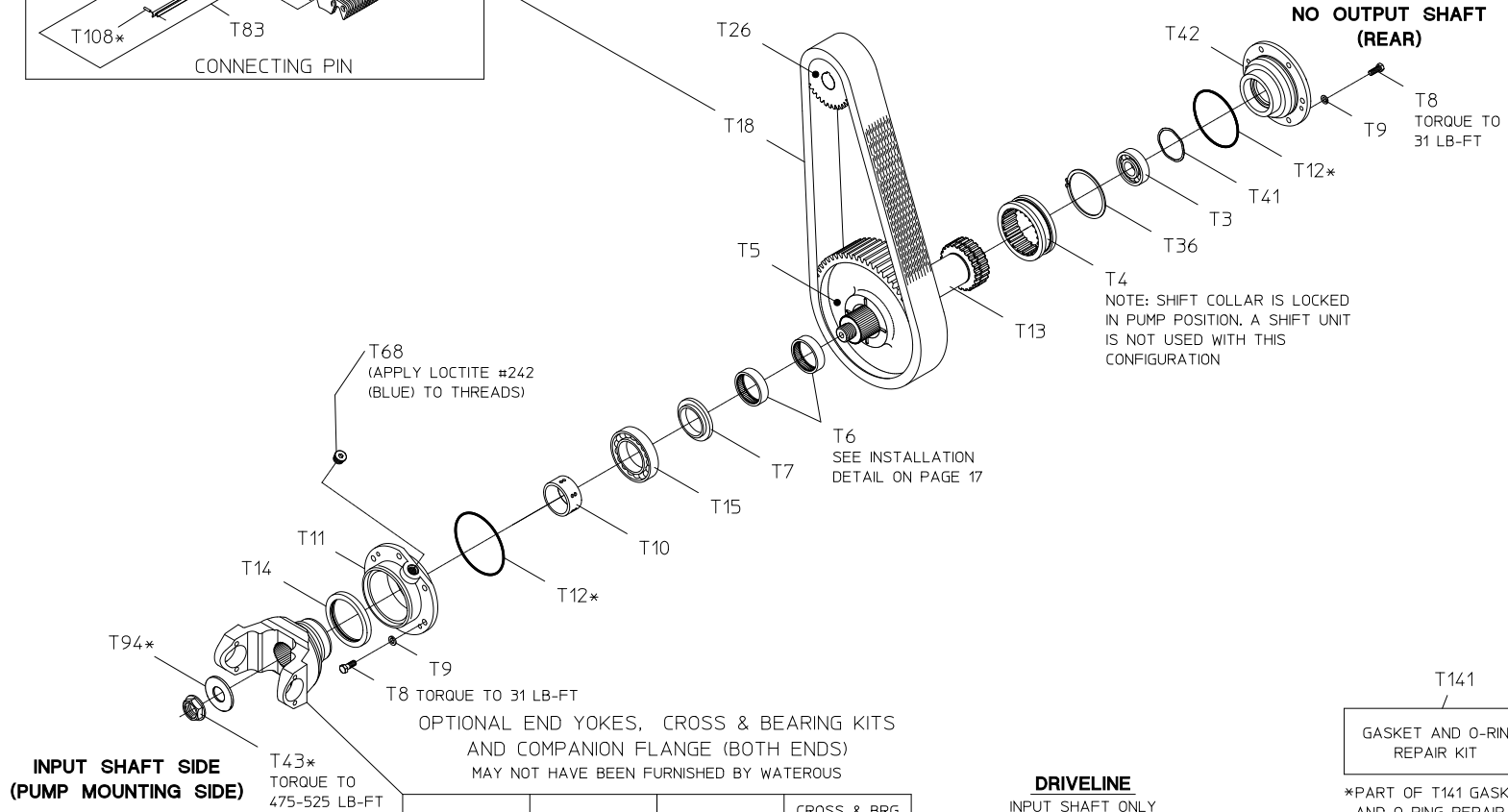
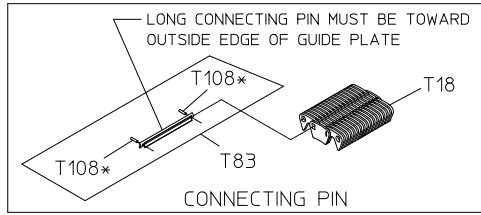

OPTIONAL END YOKE, CROSS & BEARING KITS AND COMPANION FLANGE (BOTH ENDS) MAY NOT HAVE BEEN FURNISHED BY WATEROUS

TYPE	SERIES	PART NO.	CROSS & BRG KIT NO.
END YOKE	1710 BP	V 2837	V 2839
	1810 BP	V 2838	V 2840
	1710 HR	V 4101	-
	1810 HR	V 4102	-
	SPL140	V 3388	V 3389
COMPANION FLANGE	1650/1710	V 3619	-
	1480/1610	V 3719	-
	ISO 8667	63714	-

DRIVELINE
INPUT SHAFT ONLY

T141
GASKET AND O-RING REPAIR KIT
*PART OF T141 GASKET AND O-RING REPAIR KIT

Driveline - Input Shaft Only

Cross-Section View

REF. NO.	DESCRIPTION
T3	Single Row Ball Bearing
T4	Shift Collar
T5	Drive Sprocket
T6	Needle Bearing
T7	Thrust Washer
T8	Hex Hd Screw, 3/8-16 x 1 in.
T9	Lock Washer, 3/8 in.
T10	Tachometer Pulse Generator
T11	Drive Shaft Housing
T12	O-ring, 4-3/4 x 5 in.
T13	Drive Shaft
T14	Oil Seal, 3-1/2 x 4-3/8 in.
T15	Single Row Ball Bearing
T18	Chain
T36	Retaining Ring
T41	Wave Spring, 72 mm

REF. NO.	DESCRIPTION
T42	Bearing Housing
T43	Self-Locking Nut, 1-1/4-18 in.
T57	Magnetic Drain Plug
T68	Set Screw, 5/8-18 x 5/8 in.
T94	Plain Washer, 1-1/4 in.
T141	Gasket and O-ring Repair Kit

Hardware Torque Specifications

Screw Size	Torque Specification
5/16-18 UNC	17 lb-ft
3/8-16 UNC	31 lb-ft
1/2-13 UNC	75 lb-ft
1/2-20 UNF	85 lb-ft
5/8-11 UNC	150 lb-ft

T141
 GASKET AND O-RING
 REPAIR KIT

*PART OF T141 GASKET
 AND O-RING REPAIR KIT

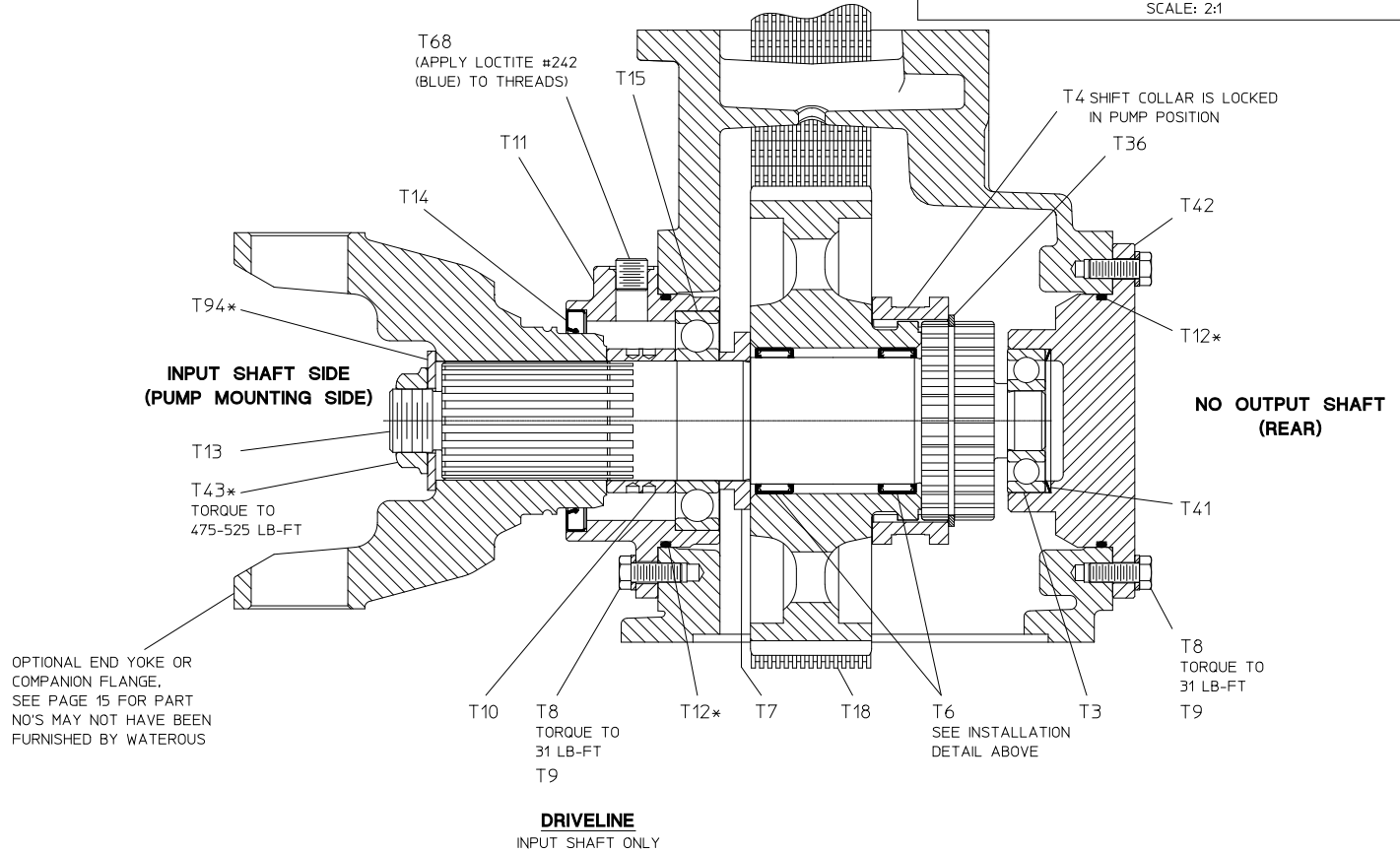
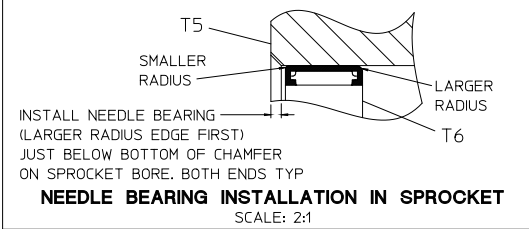

Case
Viewed from Input Side

REF. NO.	DESCRIPTION
T8	Hex Hd Screw, 3/8-16 x 1 in.
T9	Lock Washer, 3/8 in.
T16	Transmission Pan
T17	Transmission Pan O-ring, 13 x 13-3/8
T27	Breather, 1/2 NPT

REF. NO.	DESCRIPTION
T28	Case
T81	Pipe Nipple, 1/2 NPT x 1-1/2 in.
T82	Pipe Coupling, 1/2 NPT
T141	O-ring and Gasket Repair Kit

Hardware Torque Specifications

Screw Size	Torque Specification
5/16-18 UNC	17 lb-ft
3/8-16 UNC	31 lb-ft
1/2-13 UNC	75 lb-ft
1/2-20 UNF	85 lb-ft
5/8-11 UNC	150 lb-ft

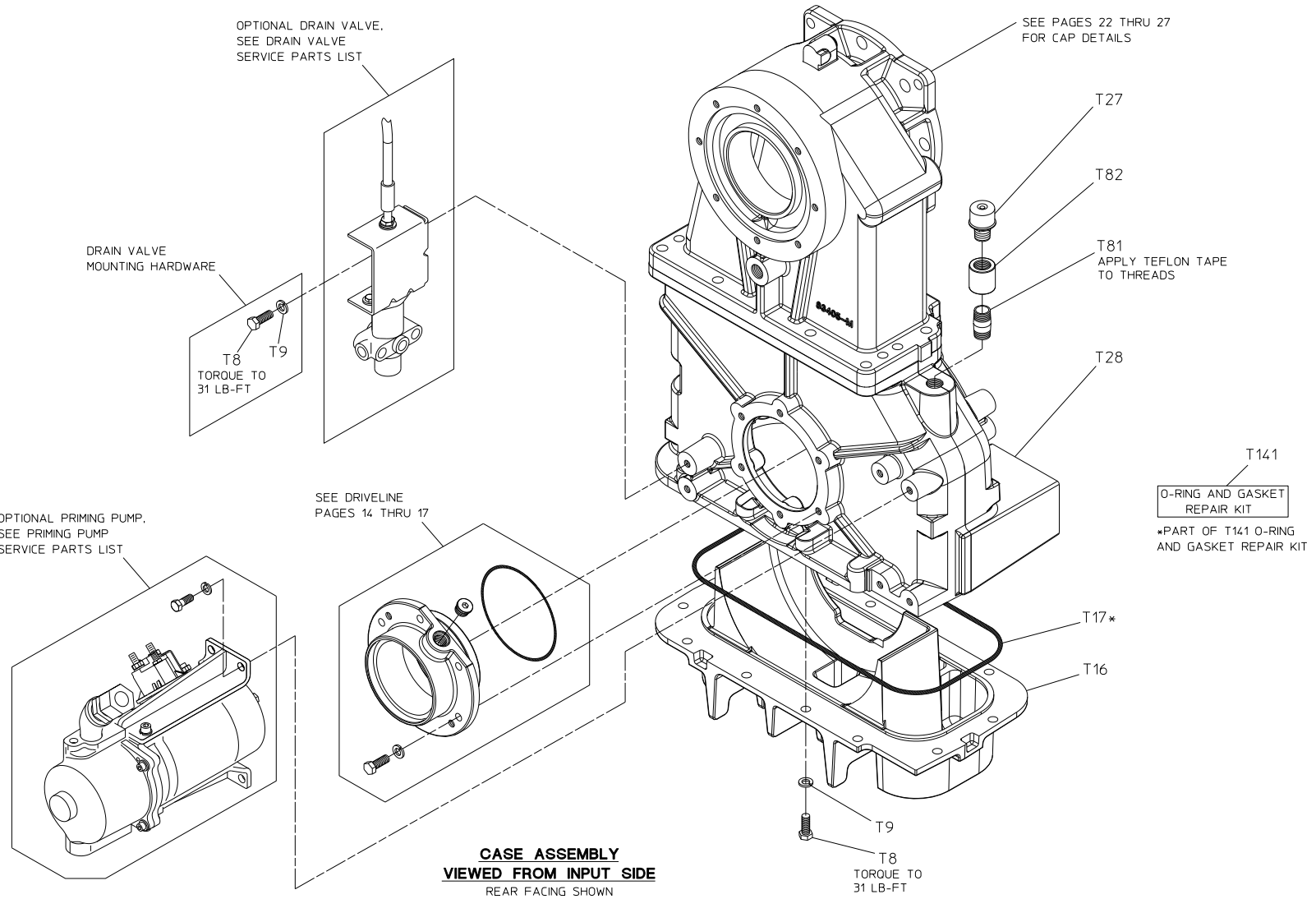

CASE ASSEMBLY
VIEWED FROM INPUT SIDE
 REAR FACING SHOWN

Case
Viewed from Output Side

REF. NO.	DESCRIPTION
T8	Hex Hd Screw, 3/8-16 x 1 in.
T9	Lock Washer, 3/8 in.
T16	Transmission Pan
T17	Transmission Pan O-ring, 13 x 13-3/8
T20	O-ring, 16.4 mm x 20.8 mm
T28	Case
T41	Pipe Plug, 1/2 NPT

REF. NO.	DESCRIPTION
T57	Magnetic Drain Plug, 3/4-16 (Includes T78)
T77	Headless Pipe Plug, 1/8 NPT
T134	Sight Plug, 3/4 NPT
T141	O-ring and Gasket Repair Kit

Hardware Torque Specifications

Screw Size	Torque Specification
5/16-18 UNC	17 lb-ft
3/8-16 UNC	31 lb-ft
1/2-13 UNC	75 lb-ft
1/2-20 UNF	85 lb-ft
5/8-11 UNC	150 lb-ft

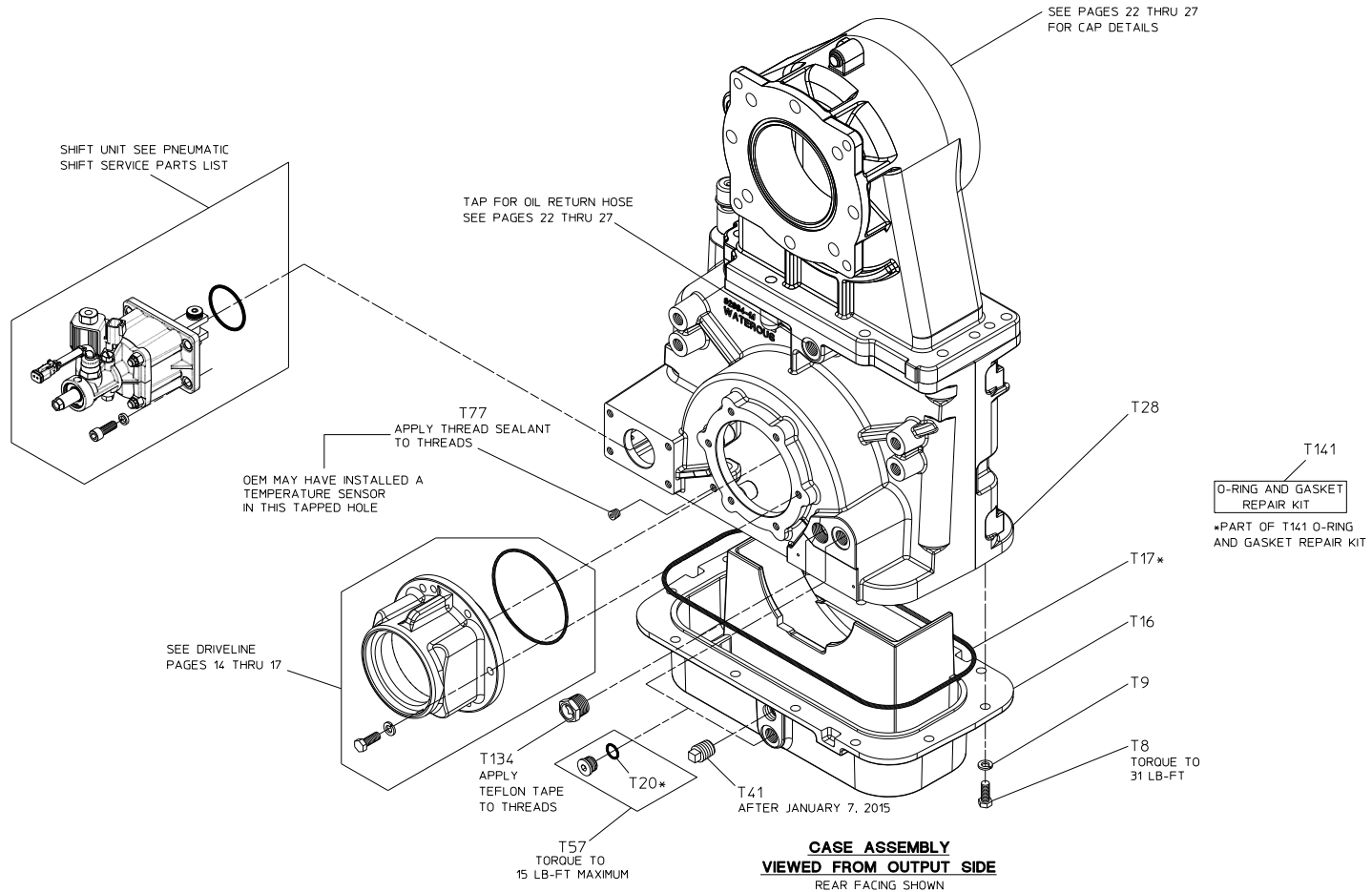

Case Cap – Hardware
Front Facing Configuration
1.77 Ratio

REF. NO.	DESCRIPTION
T28	Case
T30	Stud, 5/8-11 x 5/8-18 x 2-3/16
T34	Hex Nut, 5/8-18
T35	Lock Washer, 5/8
T51	Hex Hd Screw, 1/2-13 x 1-3/4 in.
T53	Lock Washer, 1/2
T58	Hose Assy

REF. NO.	DESCRIPTION
T65	Transmission Cap, Front Facing
T69	Hex Nut, 1/2-20
T72	Hex Hd Screw, 1/2-20 x 2-1/4 in.
T103	Dowel Pin, 1/2 x 1-3/4 in.

Hardware Torque Specifications

Screw Size	Torque Specification
5/16-18 UNC	17 lb-ft
3/8-16 UNC	31 lb-ft
1/2-13 UNC	75 lb-ft
1/2-20 UNF	85 lb-ft
5/8-11 UNC	150 lb-ft

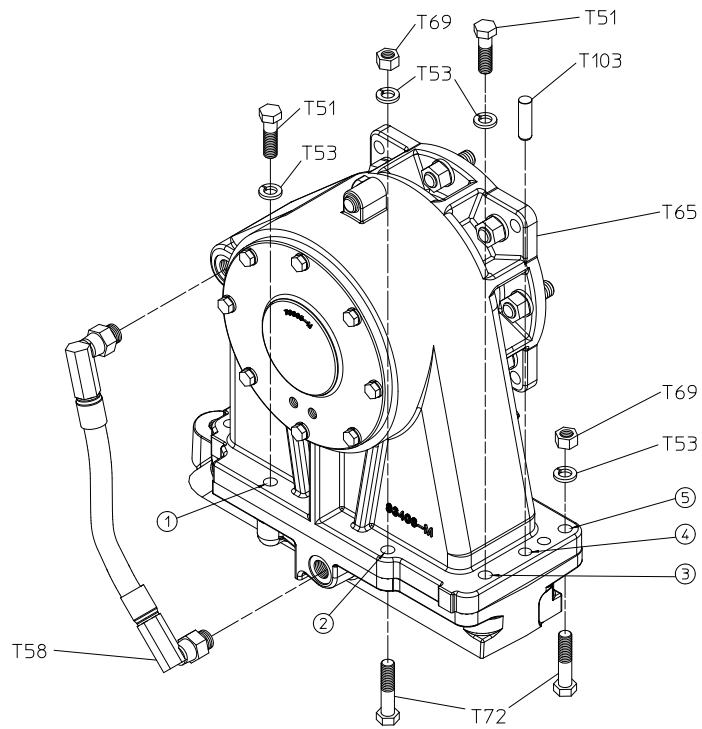

VIEWED FROM OUTPUT SIDE OF CASE

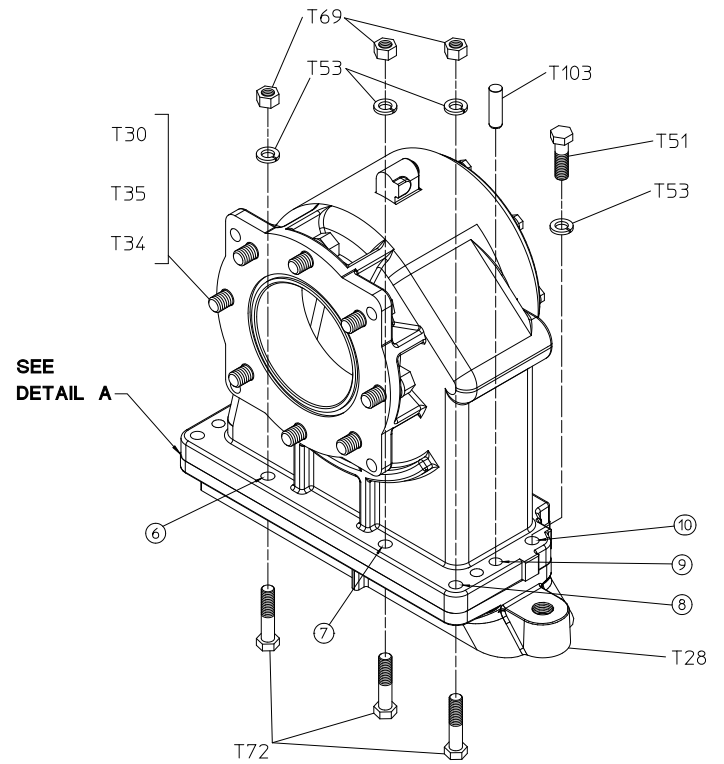

VIEWED FROM INPUT SIDE OF CASE

**SEE
DETAIL A**

APPLY A THIN BEAD OF SEALANT
AS SHOWN BY DASHED LINE

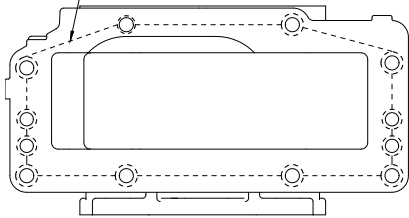

DETAIL A

APPLY LOCTITE® 518 SEALANT OR EQUIVALENT
TO MATING FLANGES

FLANGE HARDWARE BETWEEN CAP (T65) AND CASE (T28)

REF NO.	HARDWARE DESCRIPTION	HOLE NUMBER										QTY	TORQUE SPECIFICATION	
		1	2	3	4	5	6	7	8	9	10			
T51	SCREW-HEX HD, 1/2-13 X 1-3/4	1		1								1	3	75 LB-FT
T53	WASHER-LOCK, 1/2	1	1	1								1	8	-
T69	NUT-HEX, 1/2-20		1			1	1	1	1				5	85 LB-FT
T72	SCREW-HEX HD, 1/2-20 X 2-1/4	1				1	1	1	1				5	85 LB-FT
T103	PIN-DOWEL, 1/2 X 1-3/4											1	2	-

**FRONT FACING CONFIGURATION
1.77 RATIO**

Case Cap – Hardware
Front Facing Configuration
1.95 Ratio

REF. NO.	DESCRIPTION
T28	Case
T30	Stud, 5/8-11 x 5/8-18 x 2-3/16
T34	Hex Nut, 5/8-18
T35	Lock Washer, 5/8
T51	Hex Hd Screw, 1/2-13 x 2-1/4 in.
T53	Lock Washer, 1/2
T58	Hose Assy

REF. NO.	DESCRIPTION
T65	Transmission Cap, Front Facing
T69	Hex Nut, 1/2-20
T72	Hex Hd Screw, 1/2-20 x 2-3/4 in.
T103	Dowel Pin, 1/2 x 1-3/4 in.

Hardware Torque Specifications

Screw Size	Torque Specification
5/16-18 UNC	17 lb-ft
3/8-16 UNC	31 lb-ft
1/2-13 UNC	75 lb-ft
1/2-20 UNF	85 lb-ft
5/8-11 UNC	150 lb-ft

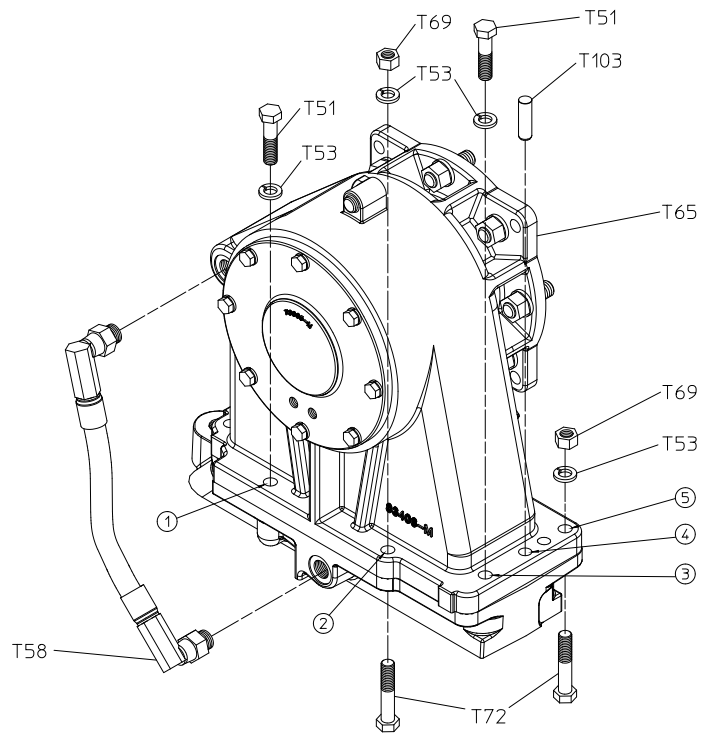

VIEWED FROM OUTPUT SIDE OF CASE

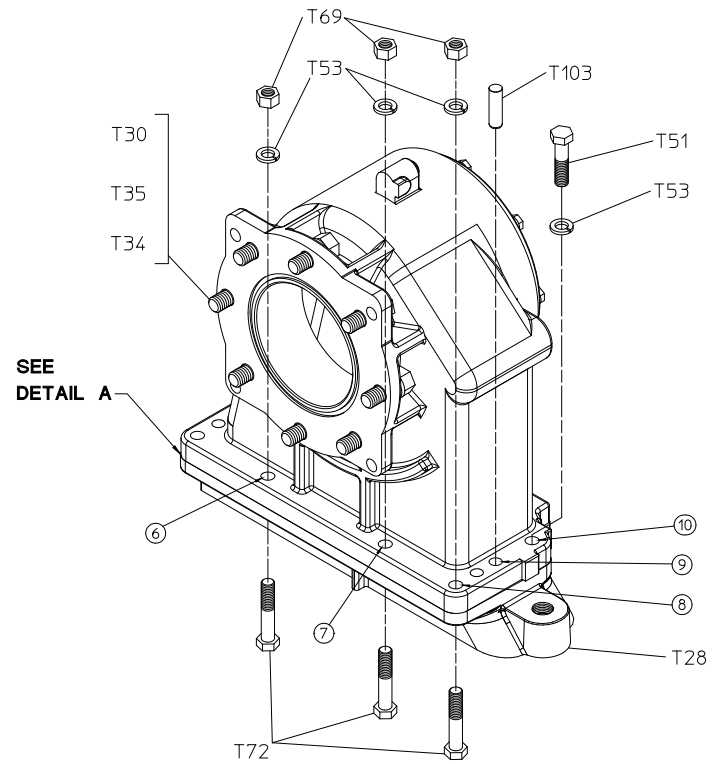

VIEWED FROM INPUT SIDE OF CASE

SEE
DETAIL A

APPLY A THIN BEAD OF SEALANT
AS SHOWN BY DASHED LINE

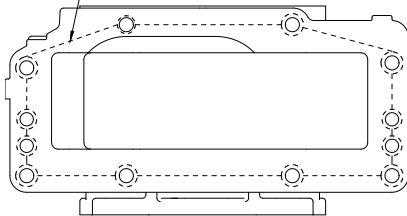

DETAIL A

APPLY LOCTITE® 518 SEALANT OR EQUIVALENT
TO MATING FLANGES

FLANGE HARDWARE BETWEEN CAP (T65) AND CASE (T28)

REF NO.	HARDWARE DESCRIPTION	HOLE NUMBER										QTY	TORQUE SPECIFICATION	
		1	2	3	4	5	6	7	8	9	10			
T51	SCREW-HEX HD, 1/2-13 X 2-1/4	1		1								1	3	75 LB-FT
T53	WASHER-LOCK, 1/2	1	1	1		1	1	1	1			1	8	-
T69	NUT-HEX, 1/2-20		1			1	1	1	1				5	85 LB-FT
T72	SCREW-HEX HD, 1/2-20 X 2-3/4		1			1	1	1	1				5	85 LB-FT
T103	PIN-DOWEL, 1/2 X 1-3/4				1						1		2	-

**FRONT FACING CONFIGURATION
1.95 RATIO**

Case Cap – Hardware
Rear Facing Configuration
1.77 Ratio

REF. NO.	DESCRIPTION
T28	Case
T30	Stud, 5/8-11 x 5/8-18 x 2-3/16
T34	Hex Nut, 5/8-18
T35	Lock Washer, 5/8
T51	Hex Hd Screw, 1/2-13 x 1-3/4 in.
T53	Lock Washer, 1/2
T58	Hose Assy
T59	Case Mounting Bracket
T60	Plain Washer, 3/4 in.
T61	Lock Washer, 3/4 in.

REF. NO.	DESCRIPTION
T65	Transmission Cap, Rear Facing
T66	Hex Hd Screw, 3/4-10 x 2 in.
T69	Hex Nut, 1/2-20
T72	Hex Hd Screw, 1/2-20 x 2-1/4 in.
T103	Dowel Pin, 1/2 x 1-3/4 in.

Hardware Torque Specifications

Screw Size	Torque Specification
5/16-18 UNC	17 lb-ft
3/8-16 UNC	31 lb-ft
1/2-13 UNC	75 lb-ft
1/2-20 UNF	85 lb-ft
5/8-11 UNC	150 lb-ft

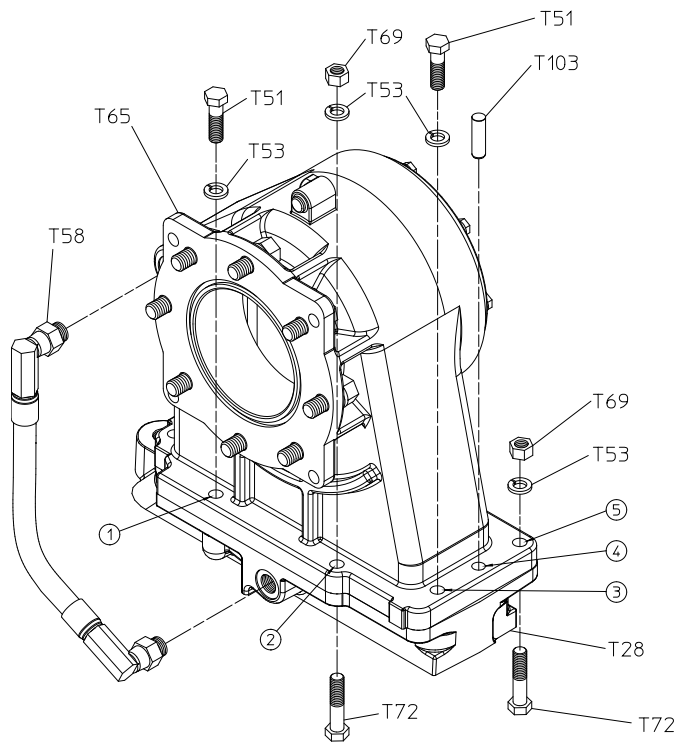

VIEWED FROM OUTPUT SIDE OF CASE

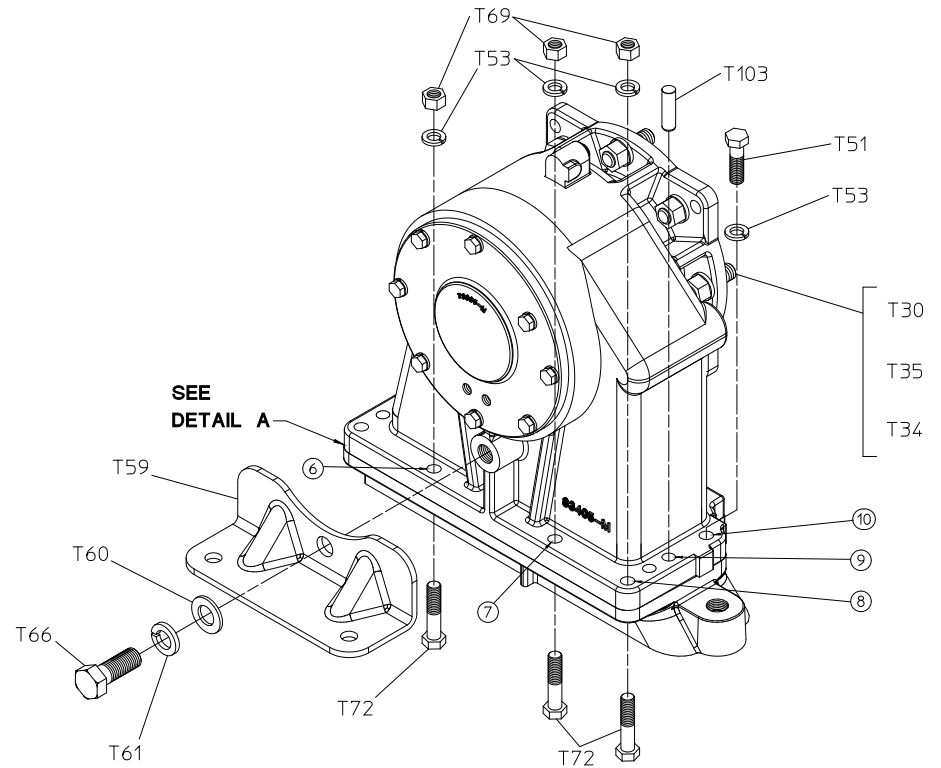

VIEWED FROM INPUT SIDE OF CASE

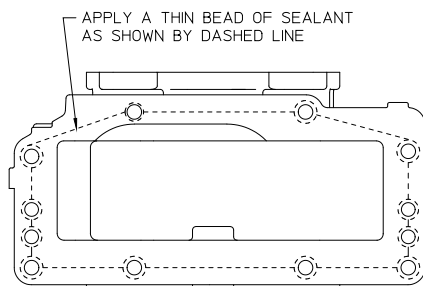

APPLY A THIN BEAD OF SEALANT AS SHOWN BY DASHED LINE

DETAIL A

APPLY LOCTITE® 518 SEALANT OR EQUIVALENT TO MATING FLANGES

FLANGE HARDWARE BETWEEN CAP (T65) AND CASE (T28)

REF NO.	HARDWARE DESCRIPTION	HOLE NUMBER										QTY	TORQUE SPECIFICATION	
		1	2	3	4	5	6	7	8	9	10			
T51	SCREW-HEX HD, 1/2-13 X 1-3/4	1		1								1	3	75 LB-FT
T53	WASHER-LOCK, 1/2	1	1	1		1	1	1	1			1	8	-
T69	NUT-HEX, 1/2-20			1		1	1	1	1				5	85 LB-FT
T72	SCREW-HEX HD, 1/2-20 X 2-1/4	1				1	1	1	1				5	85 LB-FT
T103	PIN-DOWEL, 1/2 X 1-3/4				1						1		2	-

**REAR FACING CONFIGURATION
1.77 RATIO**

Cooling Lines
 Front Facing Configuration
 1.77 and 1.95 Ratios

REF. NO.	DESCRIPTION
T37	Pipe Tee, 3/8 NPT
T38	Pipe Nipple, 3/8 x 1
T78	Adapter, 3/8 NPT x 3/8 Tube
T84	Elbow Adapter, 1/4 NPT x 3/8 Tube
T85	Nylon Tubing, 3/8 Dia.

REF. NO.	DESCRIPTION
T86	Nylon Tubing, 3/8 Dia.
T143	Street Elbow, 3/4 NPT
T144	Street Tee, 3/4 NPT
T145	Reducing Bushing, 3/4 x 3/8

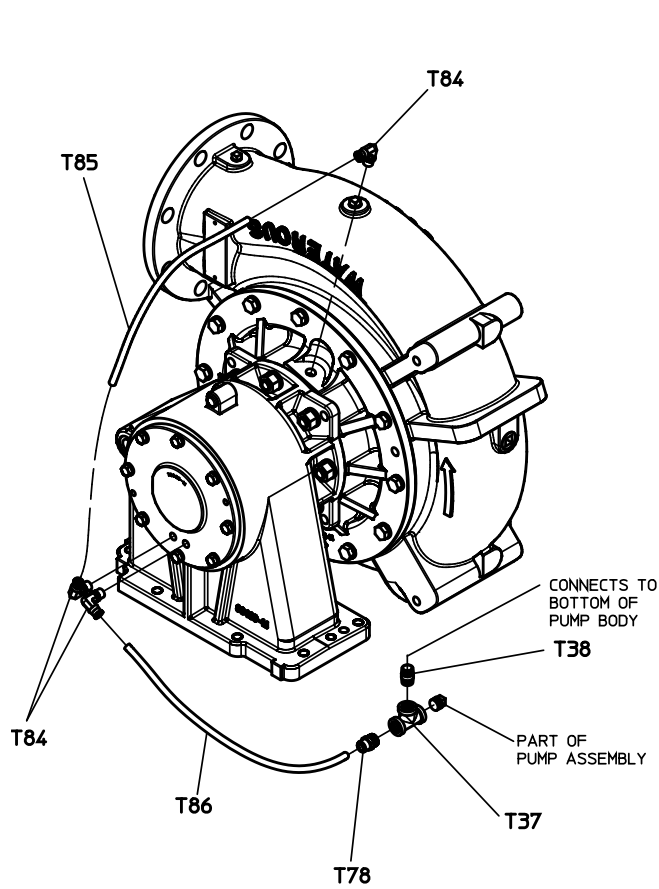

RIGHT DISCHARGE, PRIOR TO NOVEMBER 20, 2015

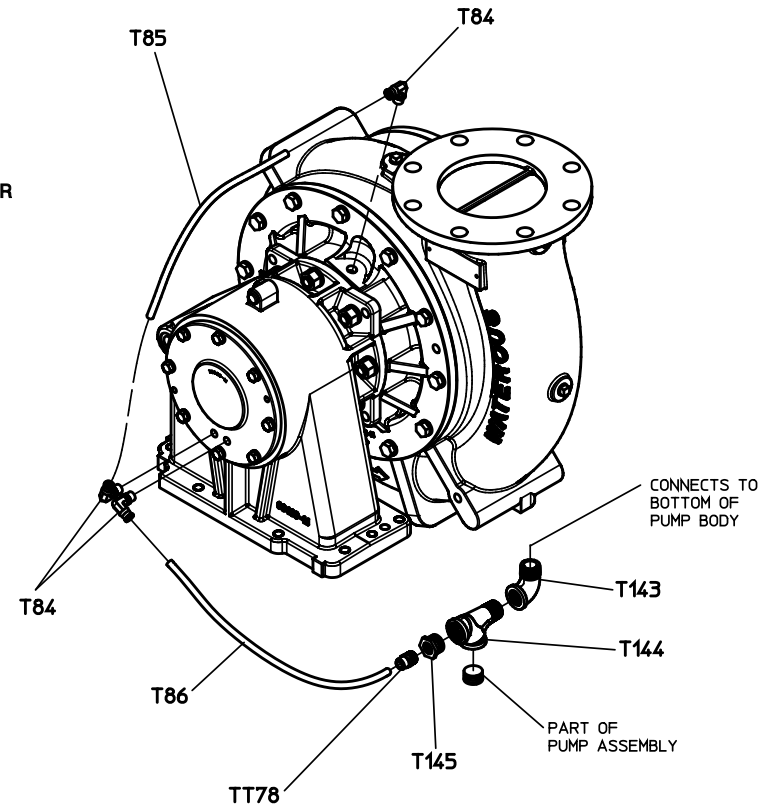
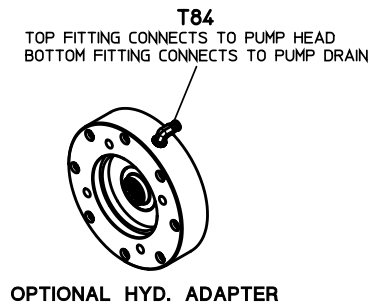

UP DISCHARGE, ALL YEARS
RIGHT DISCHARGE, AFTER NOVEMBER 20, 2015

FRONT FACING CONFIGURATIONS
1.77 AND 1.95 RATIOS

Cooling Lines
Rear Facing Configuration
1.77 Ratio

REF. NO.	DESCRIPTION
T37	Pipe Tee, 3/8 NPT
T38	Pipe Nipple, 3/8 x 1
T78	Adapter, 3/8 NPT x 3/8 Tube
T84	Elbow Adapter, 1/4 NPT x 3/8 Tube
T85	Nylon Tubing, 3/8 Dia.

REF. NO.	DESCRIPTION
T86	Nylon Tubing, 3/8 Dia.
T143	Street Elbow, 3/4 NPT
T144	Street Tee, 3/4 NPT
T145	Reducing Bushing, 3/4 x 3/8

T84
 TOP FITTING CONNECTS TO PUMP HEAD
 BOTTOM FITTING CONNECTS TO PUMP DRAIN



OPTIONAL HYD. ADAPTER

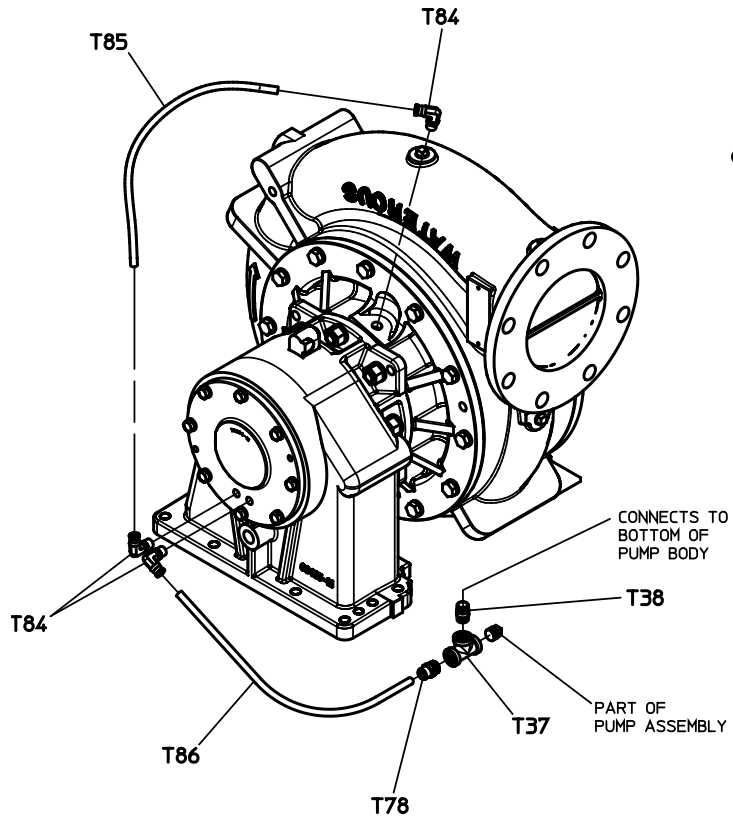

LEFT DISCHARGE, PRIOR TO NOVEMBER 20, 2015

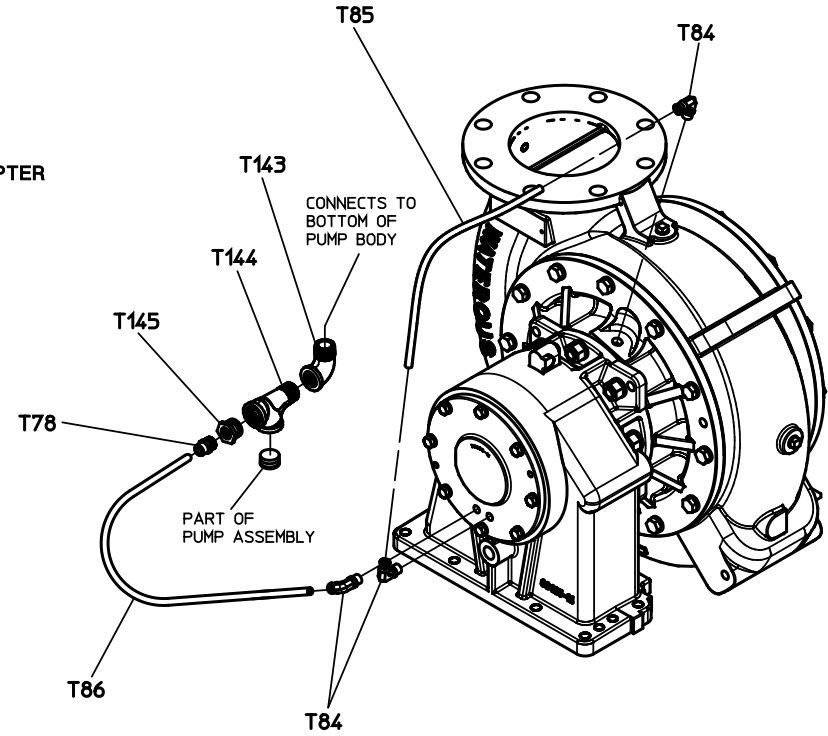

UP DISCHARGE, ALL YEARS
 LEFT DISCHARGE, AFTER NOVEMBER 20, 2015

REAR FACING CONFIGURATIONS
 1.77 RATIO