

TQB Series P.T.O. Service Parts List

Index:

Model (Located on Serial Plate)	Component	See Page	
TQB	Driveline	2, 3	
	Case	Output Shaft Side and Top	4, 5
		Input Shaft Side and Bottom	6, 7
	Cross-Section View		8, 9
	Pump Cooling Line Fittings		10, 11

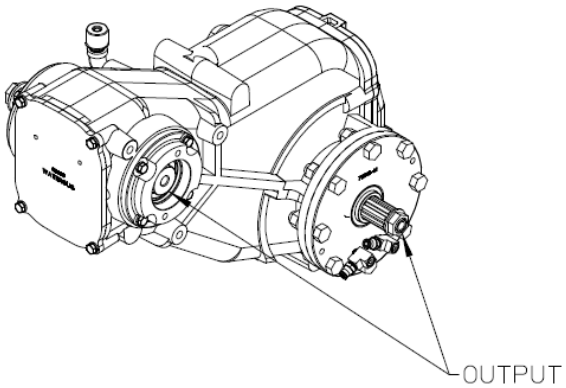

OUTPUT SHAFT SIDE

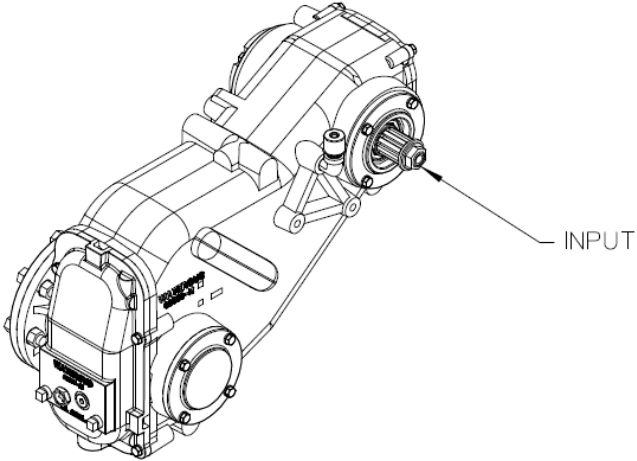

INPUT SHAFT SIDE

Driveline

REF NO.	DESCRIPTION
T1	Chain Case
T19	Drive Shaft
T20	Ball Bearing, Single Row
T21	Driven Sprocket
T22	Drive Sprocket
T23	Chain
T24	Pin Set
T25	Oil Seal Sleeve
T26	Spacer, .826 Wide

REF NO.	DESCRIPTION
T31	Wave Spring
T32	Square Key, ½ x 1-3/4
T49	Spacer, 1.16 Wide
T50	Ball Bearing, Double Row
T53	Driven Shaft
T56	Oil Seal Sleeve

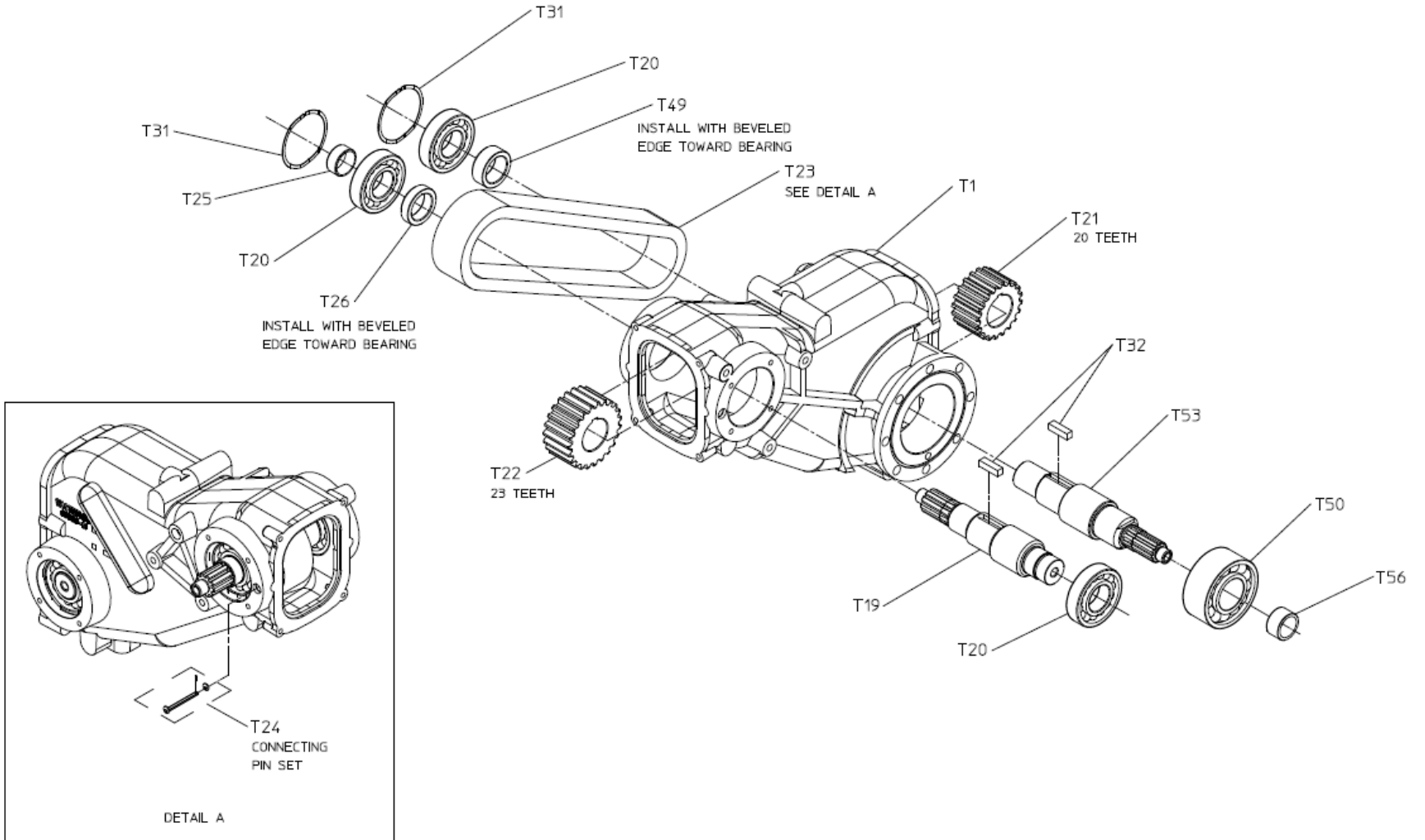

DRIVELINE

Case – Output Shaft Side and Top

REF NO.	DESCRIPTION
T4	Top Cover
T5	O-ring, 6-3/4 x 7-1/8
T9	Hydraulic Pump Adapter
T10	Oil Seal, 1-7/8 x 2-7/8 x 5/16
T11	O-ring, 4 x 4-1/4
T16	Hex Hd Screw, 3/8-16 x 1
T17	Lock Washer, 3/8
T30	Locknut Replacement Kit
T33	O-ring Replacement Kit
T37	O-ring, 4-7/8 x 5-1/8
T51	Drive Screw, #6 x 1/4

REF NO.	DESCRIPTION
T52	Oil Seal Housing
T54	Headless Pipe Plug, 3/8
T55	Headless Pipe Plug, 3/8
T57	Hex Hd Screw, 5/8-18 x 2-1/4
T58	Hex Nut, 5/8-18
T59	Lock Washer, 5/8
T60	O-ring, 7 x 7-1/4
T62	Oil Seal, 2 x 2-5/8 x 5/16
T63	Tube, 1/2 x .69"
T64	Street Tee, 1/4
T65	Adapter, 1/4 NPT x 3/8 Push-Connect
T66	Headless Pipe Plug, 1/4

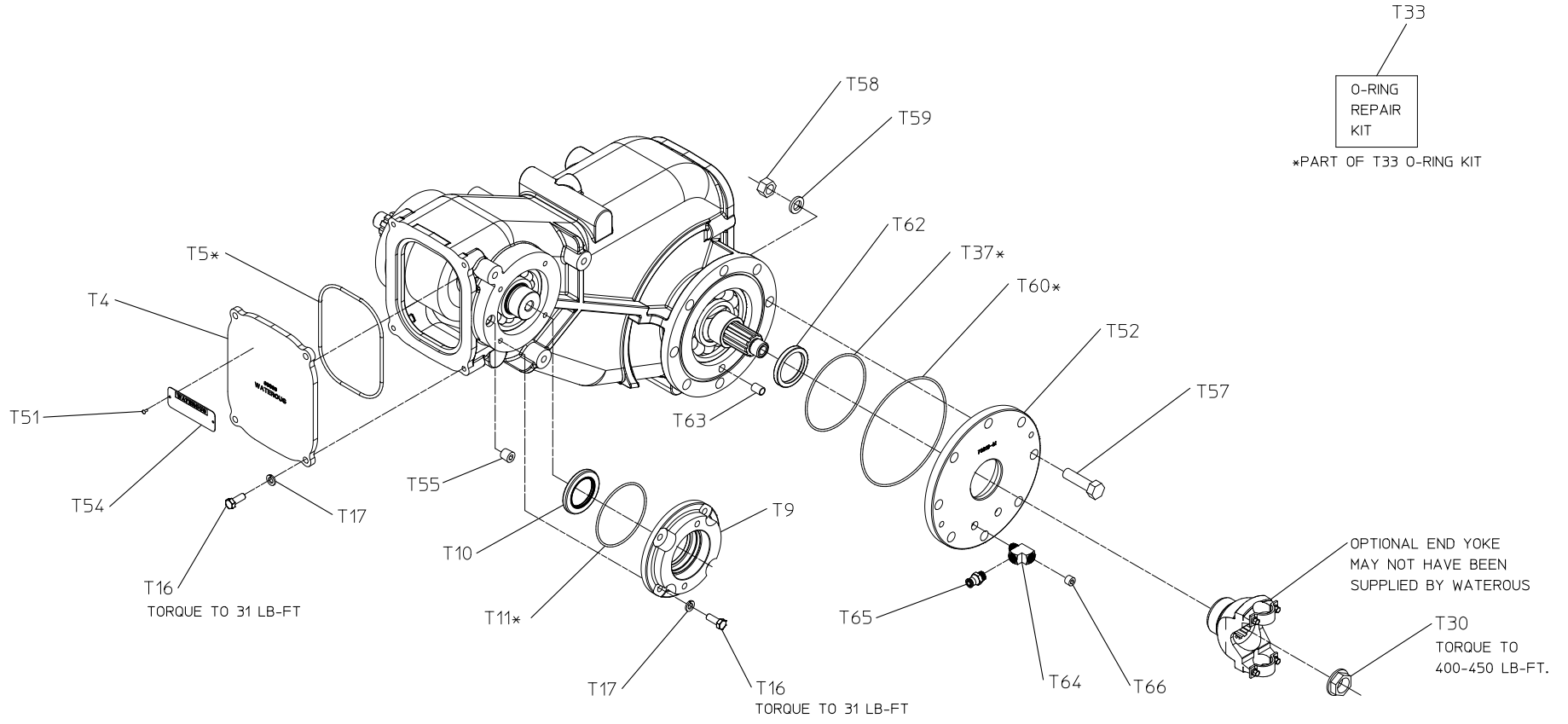

CASE – OUTPUT SHAFT SIDE AND TOP
OUTPUT SHAFT END

TQB Case Assembly – Input Shaft End

REF NO.	DESCRIPTION
T2	Bottom Pan
T3	O-ring, 10-1/2 x 10-7/8
T6	Bearing Cover
T7	Oil Seal Housing
T8	Oil Seal 2 x 2-3/4 x 5/16
T11	O-ring, 4 x 4-1/4
T13	Sight Plug
T14	Breather
T15	Street Elbow, 1/2

REF NO.	DESCRIPTION
T16	Hex Hd Screw, 3/8-16 x 1
T17	Lock Washer, 3/8
T29	Yoke Washer
T30	Locknut Replacement Kit
T33	O-ring Replacement Kit
T35	O-ring, 16.4mm x 20.8mm
T48	Pipe Plug, 1/2
T55	Headless Pipe Plug, 3/8
T67	Pipe Plug, 3/4

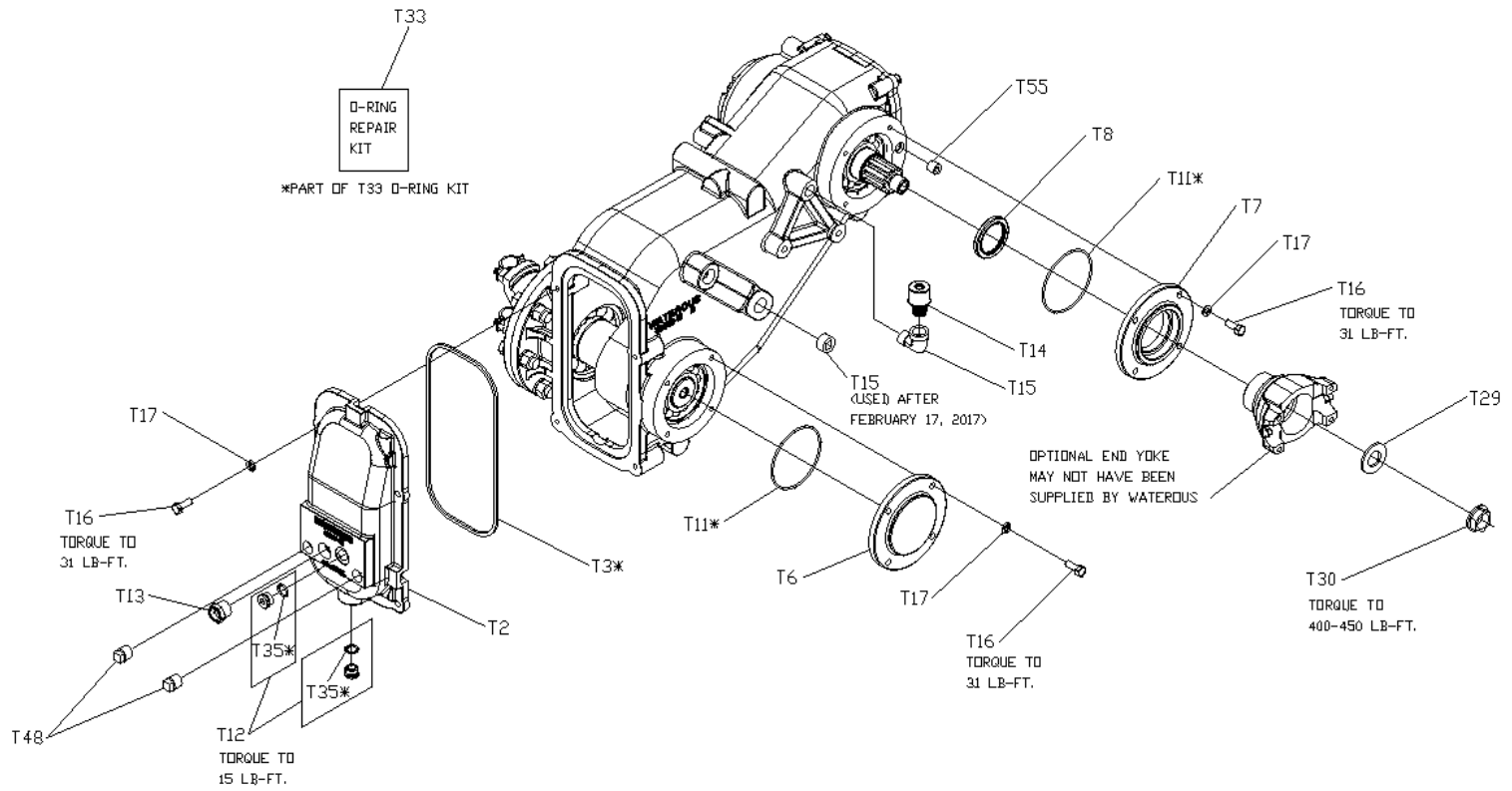

CASE - INPUT SHAFT SIDE AND BOTTOM
INPUT SHAFT END

Cross-Section View

REF NO.	DESCRIPTION
T1	Chain Case
T6	Bearing Cover
T7	Oil Seal Housing
T8	Oil Seal 2 x 2-3/4 x 5/16
T9	Hydraulic Pump Adapter
T10	Oil Seal, 1-7/8 x 2-7/8 x 5/16
T11	O-ring, 4 x 4-1/4
T19	Drive Shaft
T20	Ball Bearing, Single Row
T21	Driven Sprocket
T22	Drive Sprocket
T25	Oil Seal Sleeve
T26	Spacer, .826 Wide
T29	Yoke Washer

REF NO.	DESCRIPTION
T30	Locknut Replacement Kit
T31	Wave Spring
T32	Square Key, 1/2 x 1-3/4
T33	O-ring Replacement Kit
T37	O-ring, 4-7/8 x 5-1/8
T49	Spacer, 1.16 Wide
T50	Ball Bearing, Double Row
T52	Oil Seal Housing
T53	Driven Shaft
T56	Oil Seal Sleeve
T60	O-ring, 7 x 7-1/4
T62	Oil Seal, 2 x 2-5/8 x 5/16
T63	Tube, 1/2 x .69"

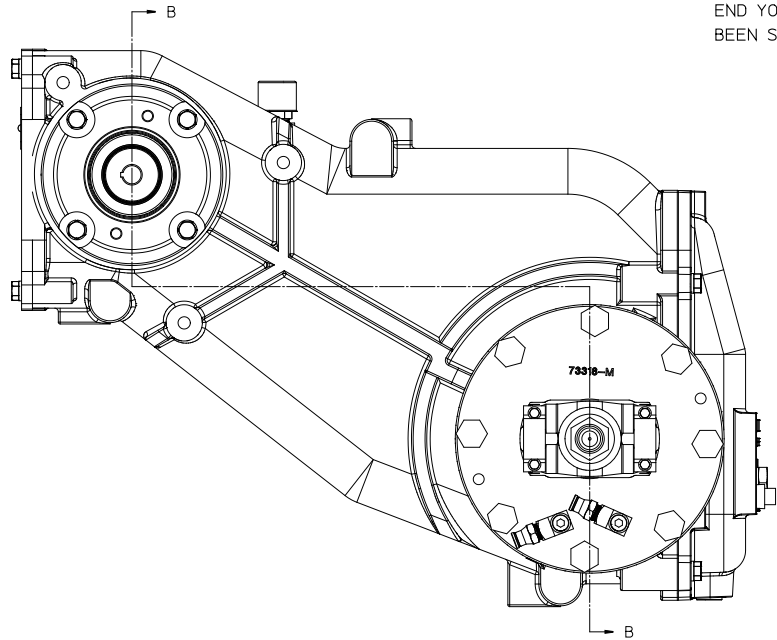

OPTIONAL SPL90 SERIES
END YOKE (MAY NOT HAVE
BEEN SUPPLIED BY WATEROUS)

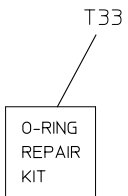

*PART OF T33 O-RING KIT

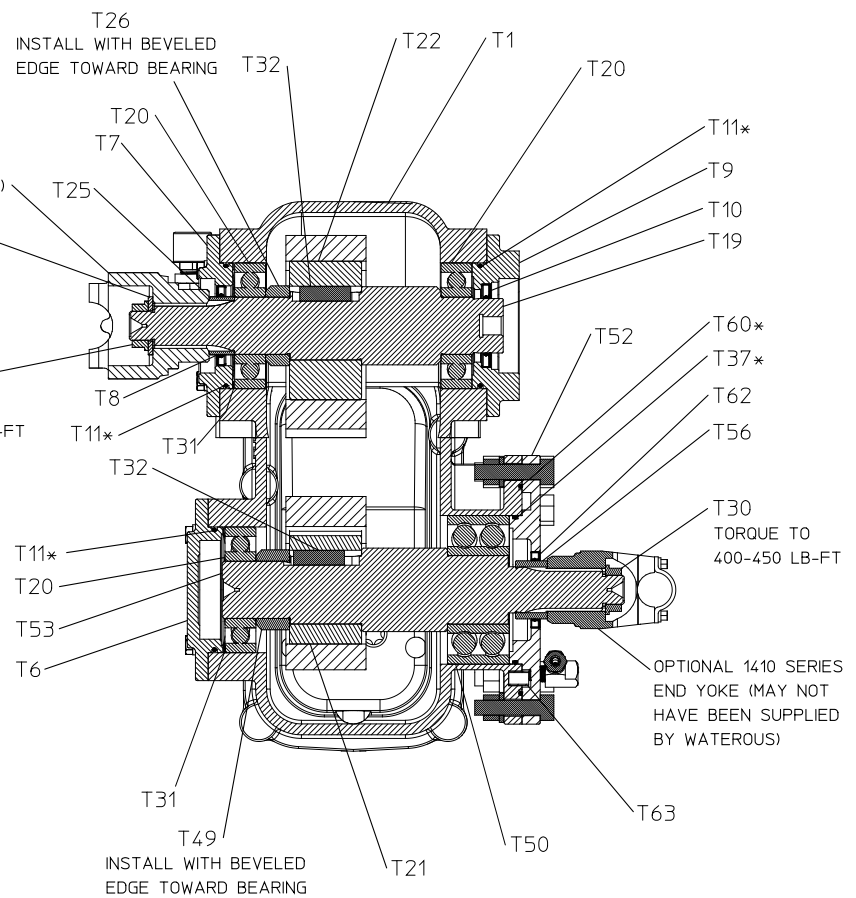

SECTION B-B

CROSS-SECTION VIEW

Pump Cooling Line Fittings

REF NO.	DESCRIPTION
T75	Street Tee, 1/4 NPT

REF NO.	DESCRIPTION
T76	Adapter, 1/4 NPT x 3/8 Push-Connect

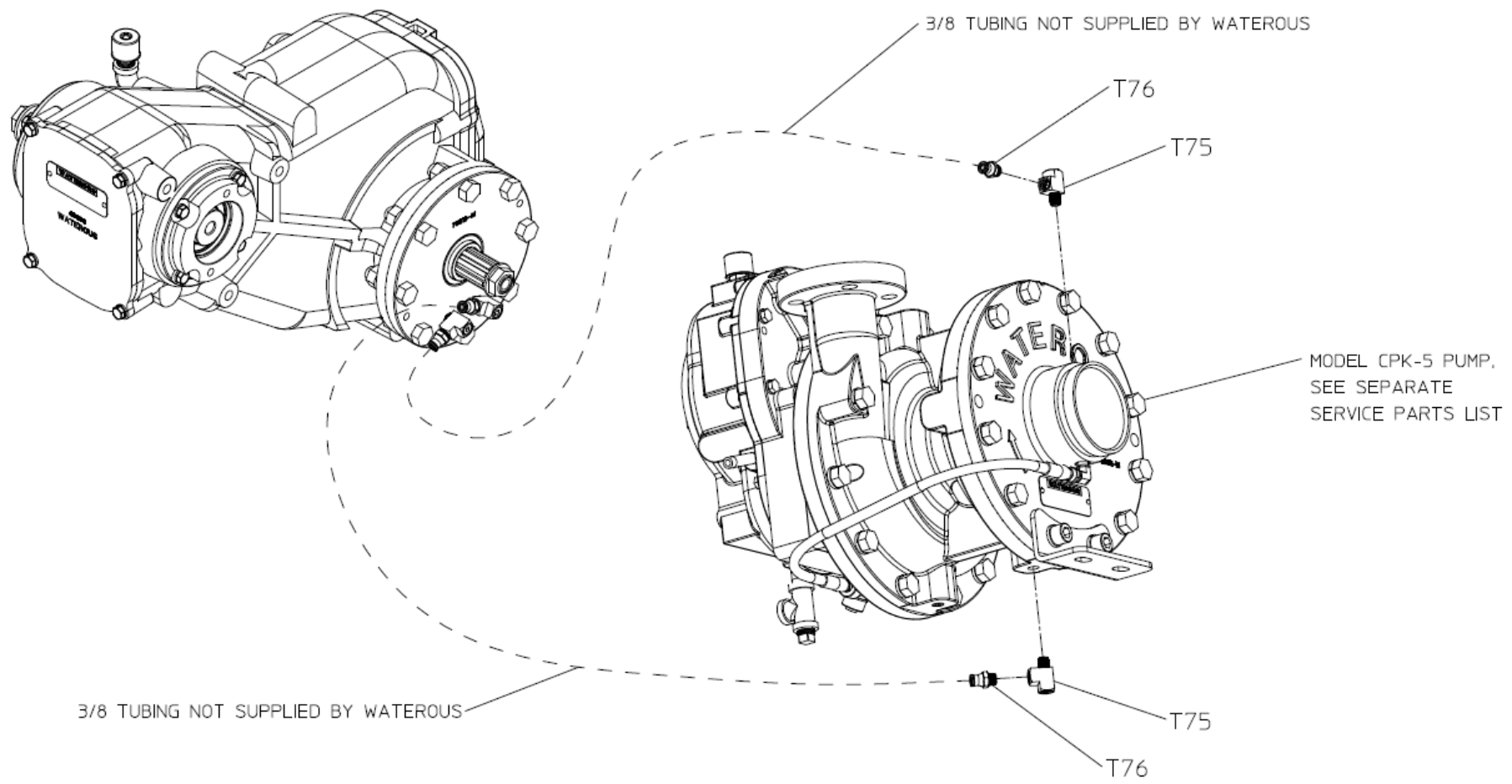

PUMP COOLING LINE FITTINGS