

## Air Compressor Service Parts List Model 150-ESD

Used with CXN, CXS, CXV Series Fire Pumps and TC20 Series PTO's

Index:

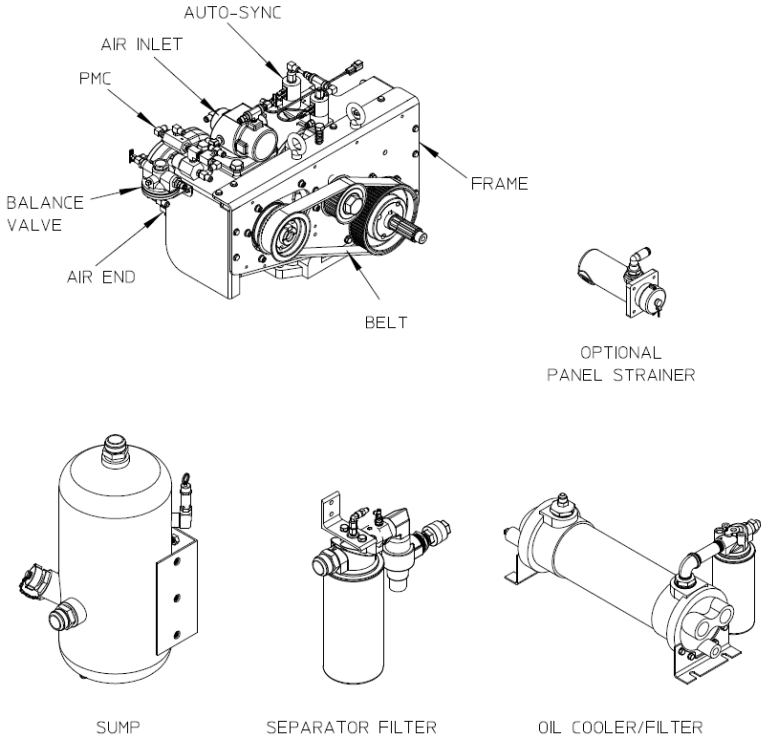

Components		See Page	
		CXN, CXS, CXV Series Fire Pumps	TC20 Series PTO's
Compressor	Mounting	2, 3	4, 5
	Belt Drive	6, 7	6, 7
	Frame	8, 9	8, 9
	Air End	10, 11	10, 11
	Air Inlet	12, 13	12, 13
	PMC	14, 15	14, 15
	Balance Valve	16, 17	16, 17
	Auto-Sync	18, 19	18, 19
Sump		20, 21	20, 21
Separator Filter		22, 23	22, 23
Oil Cooler and Oil Filter	In-Line Strainer	24, 25	24, 25
	Panel Strainer	26, 27	26, 27
Schematic	Air Circuit	28, 29	28, 29
	Hydraulic	In-Line Strainer	30, 31
		Panel Strainer	32, 33
	Electrical	34, 35	34, 35
Panel Components		36, 37	36, 37
Hose and Fitting Kit Air Pressure Gauge Air Discharge Manifold CAFS Discharge		Optional from Waterous, See Separate Service Parts List	

**Compressor – Mounting**  
CX Series Pumps

REF NO.	DESCRIPTION
8	Compressor Bracket
34	Hex Hd Screw, 3/8-16 x 1 in.
36	Hex Hd Screw, 1/2-13 x 1-1/2 in.
38	Lock Washer, 3/8 in.
40	Hex Hd Screw, M8-1.25 x 30mm

REF NO.	DESCRIPTION
44	Lock Washer, 8mm
200	Compressor Subassembly (Includes 201-280)

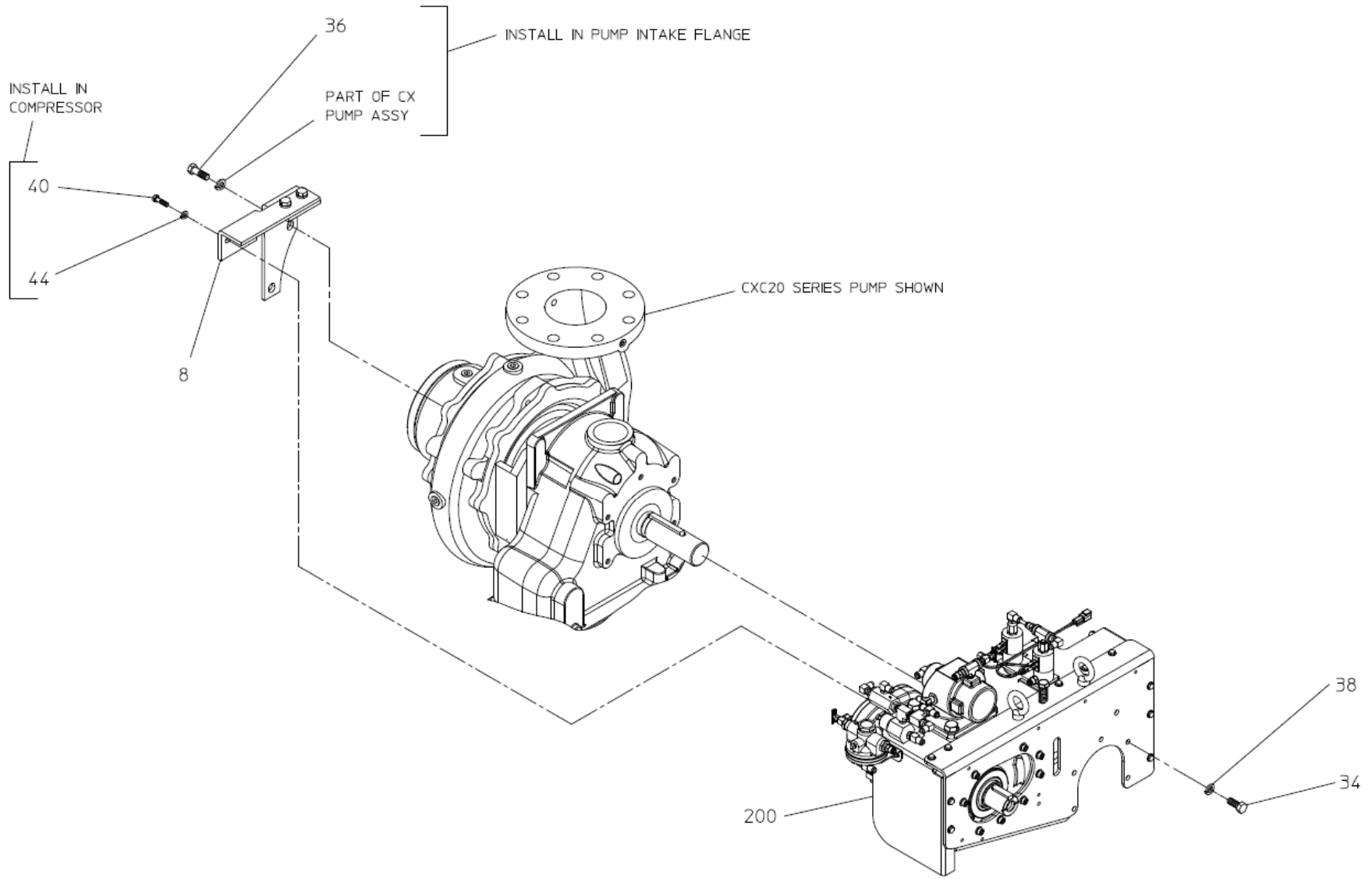

COMPRESSOR – MOUNTING  
CX SERIES PUMPS

## Compressor – Mounting

TC20 Series P.T.O.'s

REF NO.	DESCRIPTION
15	Mounting Bracket
34	Hex Hd Screw, 3/8-16 x 1 in.
38	Lock Washer, 3/8 in.
41	Hex Hd Screw, M16-2 x 30mm

REF NO.	DESCRIPTION
47	Lock Washer, 16mm
200	Compressor Subassembly (Includes 201-280)

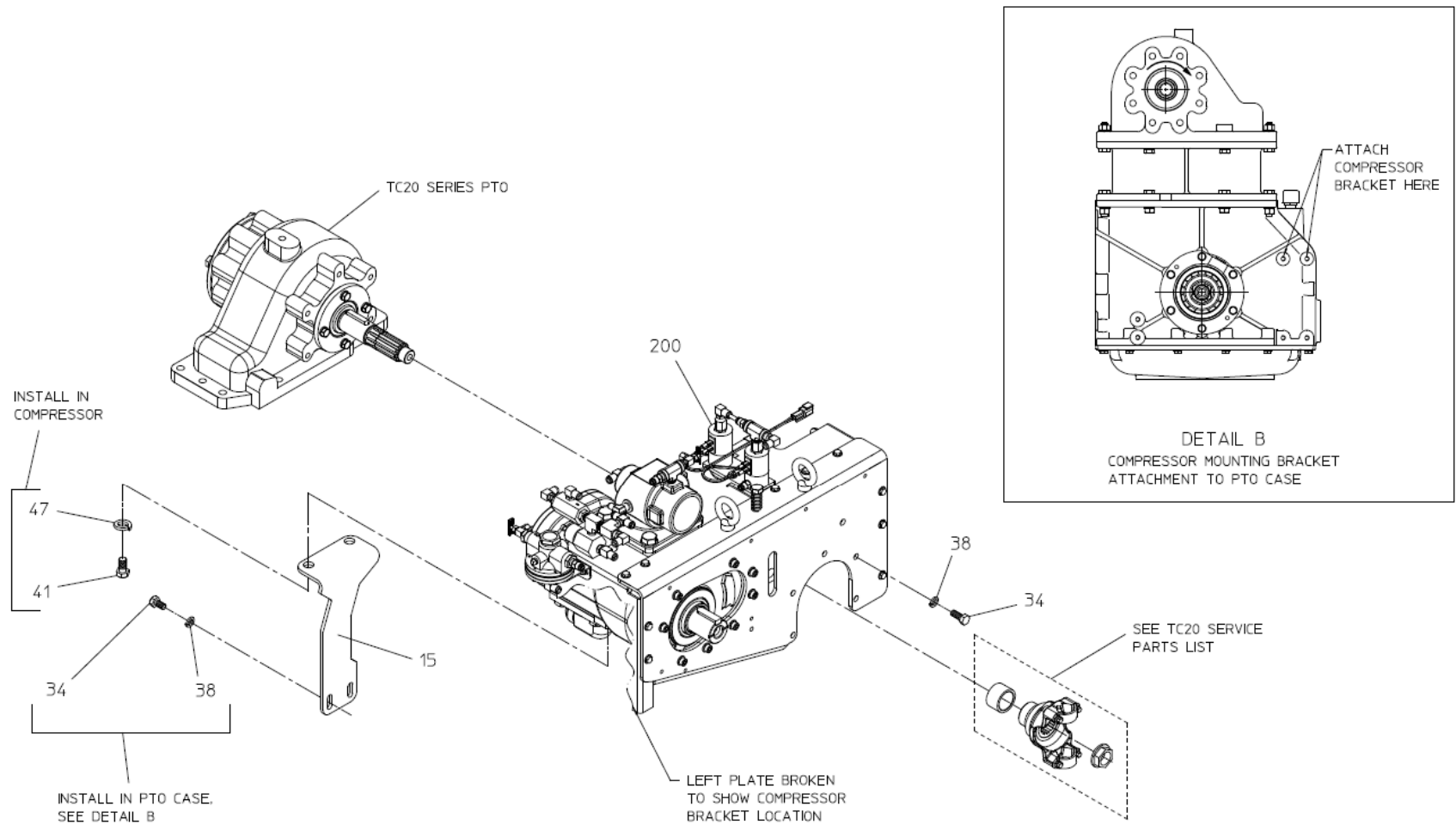

COMPRESSOR — MOUNTING  
TC20 SERIES P.T.O.

## Compressor – Belt Drive

REF NO.	DESCRIPTION
2	Idler Spacer
3	Taper Lock Bushing
4	Driven Sprocket
12	Drive Sprocket

REF NO.	DESCRIPTION
16	Taper Lock Bushing
20	Idler Sprocket
21	Drive Belt

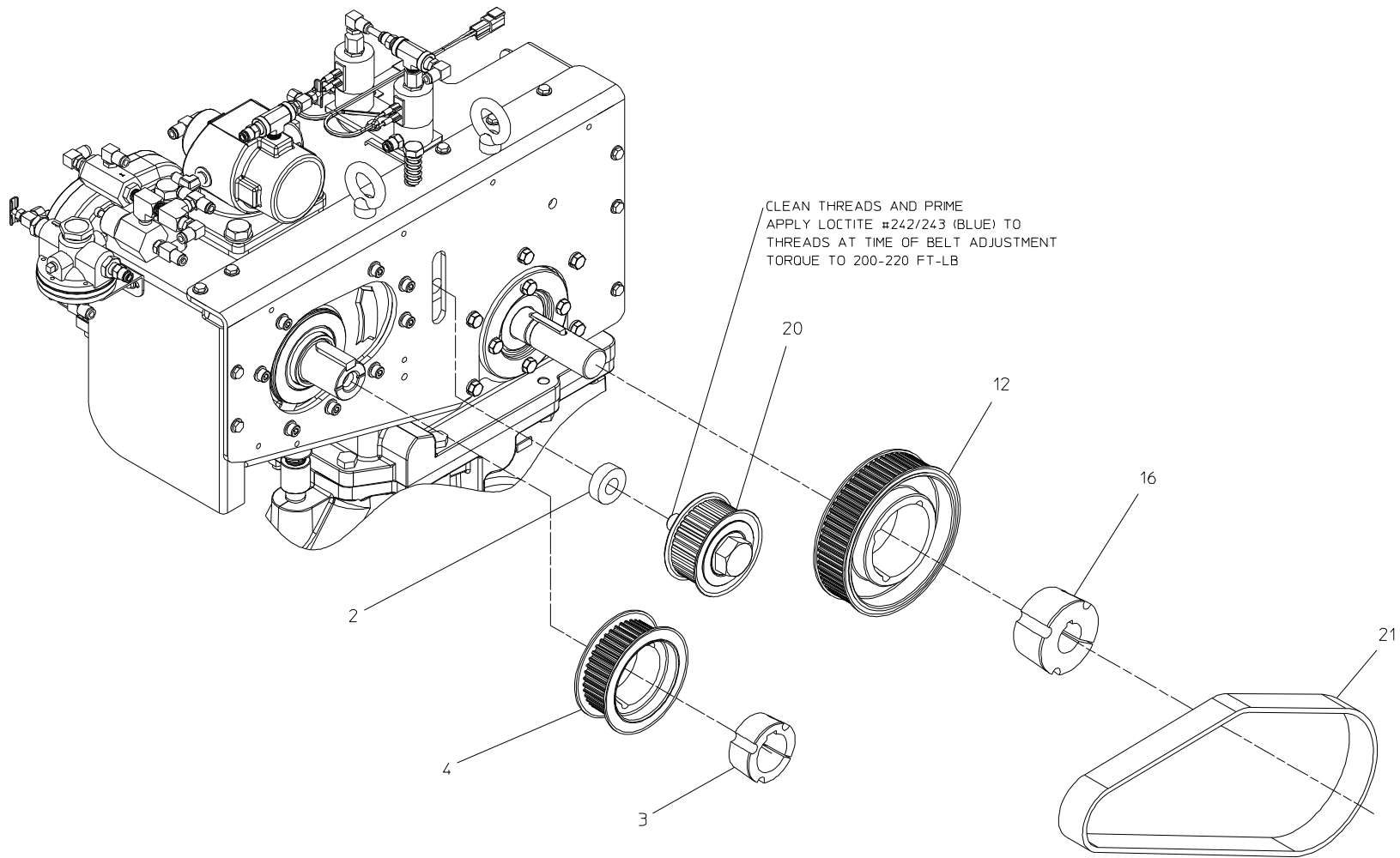

**COMPRESSOR - BELT DRIVE**

## Compressor – Frame

REF NO.	DESCRIPTION
210	U-Style Nut, 1/4-20
221	Bolt Eye, M12-1.75 x 21mm
242	Idler Adjustment Angle
244	Belt Tensioner Spring
249	Hex Hd Screw, 1/4-20 x 1 in.
252	Flat Washer, 1/4 in.
254	Hex Hd Screw, 1/2-13 x 6 in. (Fully Threaded)

REF NO.	DESCRIPTION
258	Hex Hd Screw, M8-1.25 x 20mm
259	Hex Hd Screw, M8-1.25 x 90mm
260	Flat Washer, 8mm
264	Left Bracket
265	Right Bracket
266	Compressor Plate





## Compressor – Air End

REF NO.	DESCRIPTION
219	Straight Adapter, M12 x 4 MJIC
223	Hose Assembly
224	Oil Return Tee
228	Outlet Gasket
229	Straight Adapter, M22-1.5 x 8 MJIC
230	Outlet Flange

REF NO.	DESCRIPTION
234	90 Deg. Elbow, 1-1/4 MNPT x 24 MJIC
241	Air End, CF75D8
251	O-ring, 3-7/8 x 4-1/4 in.
257	Hex Hd Screw, M16-2 x 30mm
275	Replacement Compressor Kit

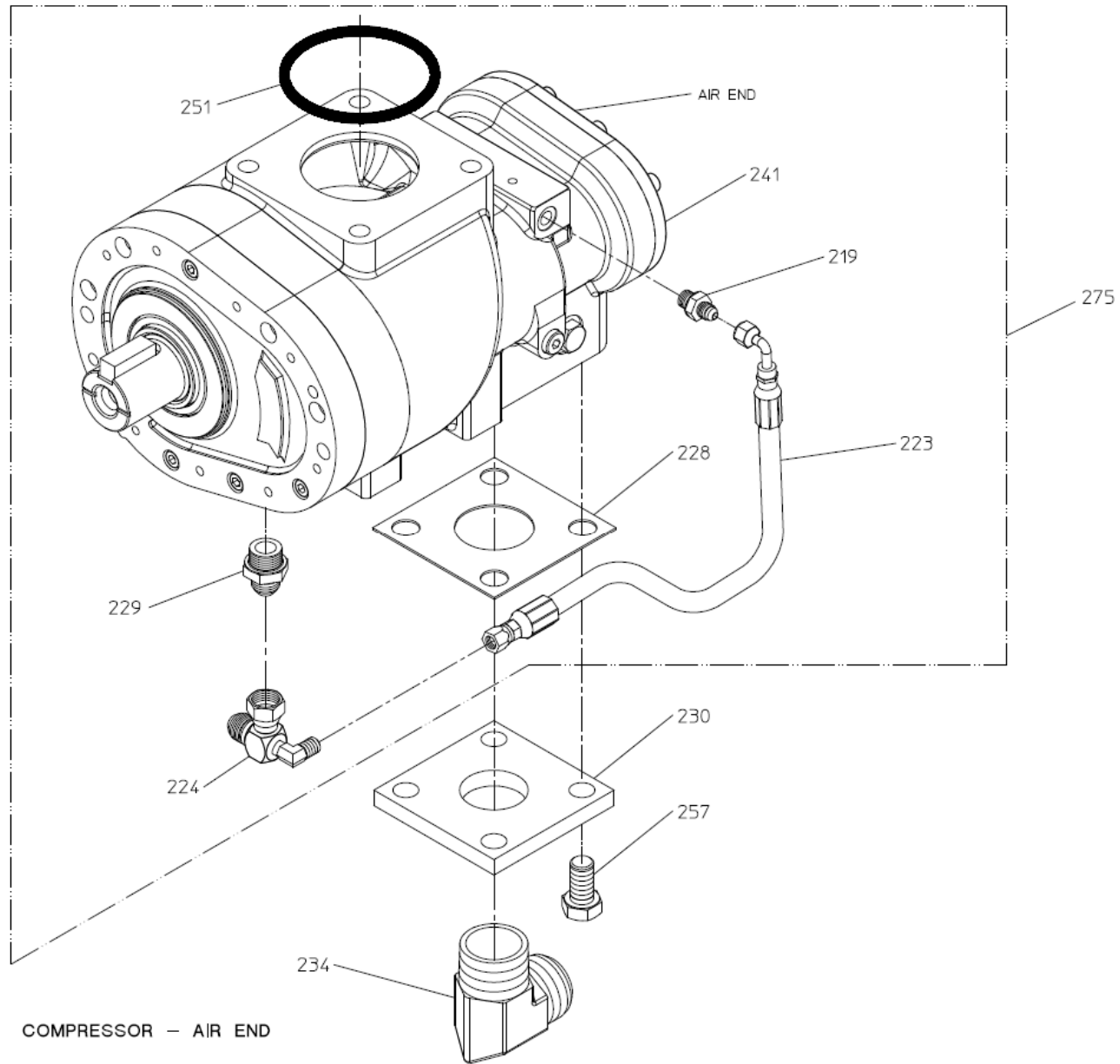

## Compressor – Air Inlet

REF NO.	DESCRIPTION
80	Inlet Adapter, 3 x 3 in.
81	Hose Clamp, 3-3/4 in.
82	T-Bolt Hose Clamp, 3-1/2 in.
83	Air Filter
84	90 Deg. Elbow, 3 in. (Rubber)
205	Trim Valve, 1/8 MNPT x 1/4 AB
206	Reducing Bushing, 1/4 NPT x 1/8 NPT
208	Tee, 1/4 FNPT x 1/4 FNPT x 1/4 MNPT

REF NO.	DESCRIPTION
211	Straight Adapter, 1/4 MNPT x 1/4 AB
214	90 Deg. Elbow, 1/4 MNPT x 1/4 AB
216	Tee, 4 MJIC x 1/4 MNPT x 1/4 AB x 1/4 AB
235	90 Degree Air Inlet
251	O-ring, 3-7/8 x 4-1/4 in.
257	Hex Hd Screw, M16-2 x 30mm
261	Flat Washer, 16mm
271	90 Deg. Elbow, 4 MJIC x 1/4 MNPT
281	Internal Support Sleeve

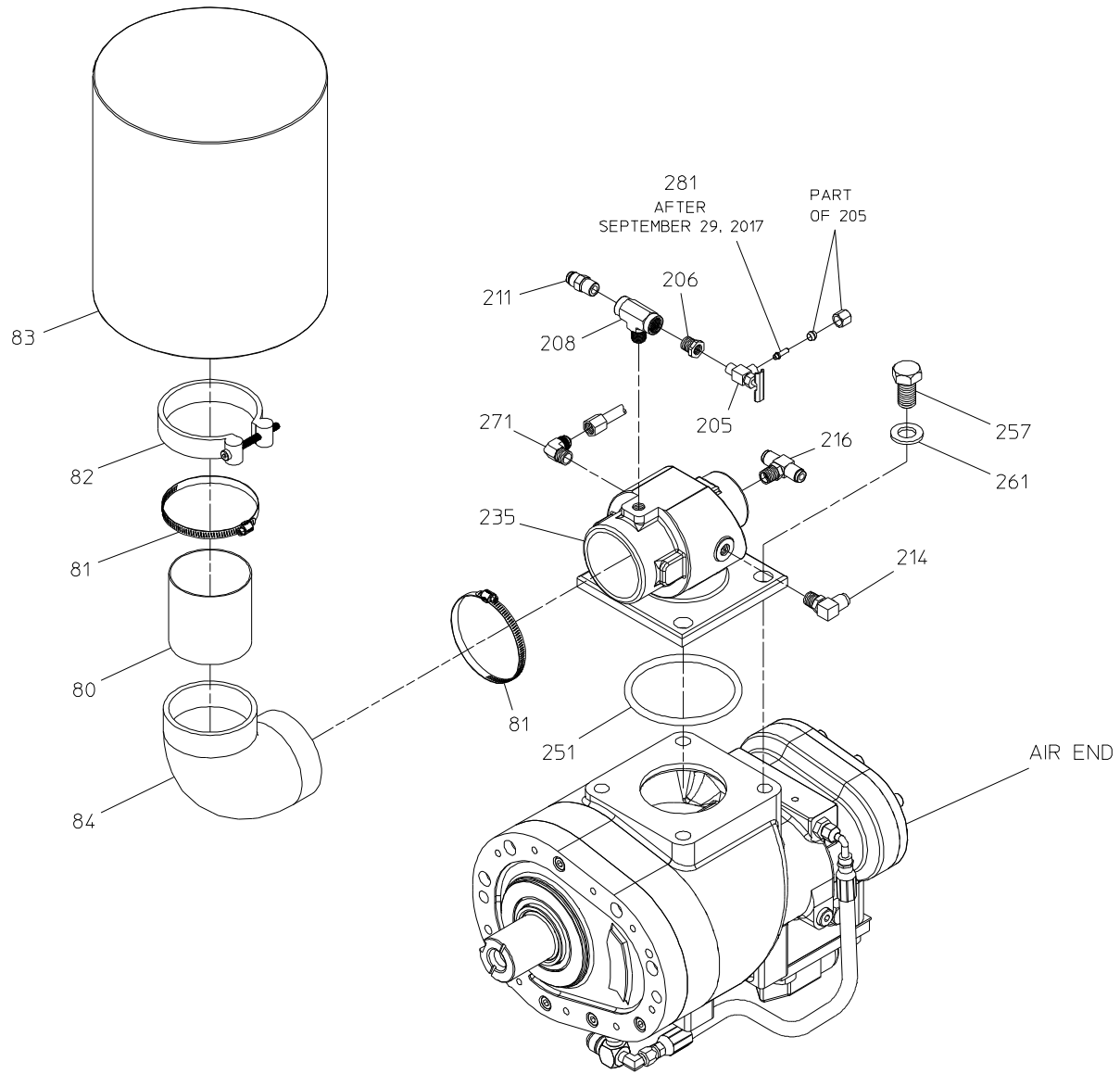

**COMPRESSOR – AIR INLET**

ALSO SEE AIR CIRCUIT AND HYDRAULIC SCHEMATIC

## Compressor – PMC

REF NO.	DESCRIPTION
214	90 Deg. Elbow, 1/4 MNPT x 1/4 AB
216	Branch Tee, 1/4 MNPT x 1/4 AB x 1/4 AB
217	Run Tee, 1/4 MNPT x 1/4 AB x 1/4 AB
222	Female Branch Street Tee, 1/4 NPT
237	Blow Down Valve

REF NO.	DESCRIPTION
238	Pressure Regulator
277	Hex Hd Screw, 3/8-16 x 1/2 in.
278	Lock Washer, 3/8 in.
280	Pipe Nipple, 1/4 MNPT x 7/8 in.

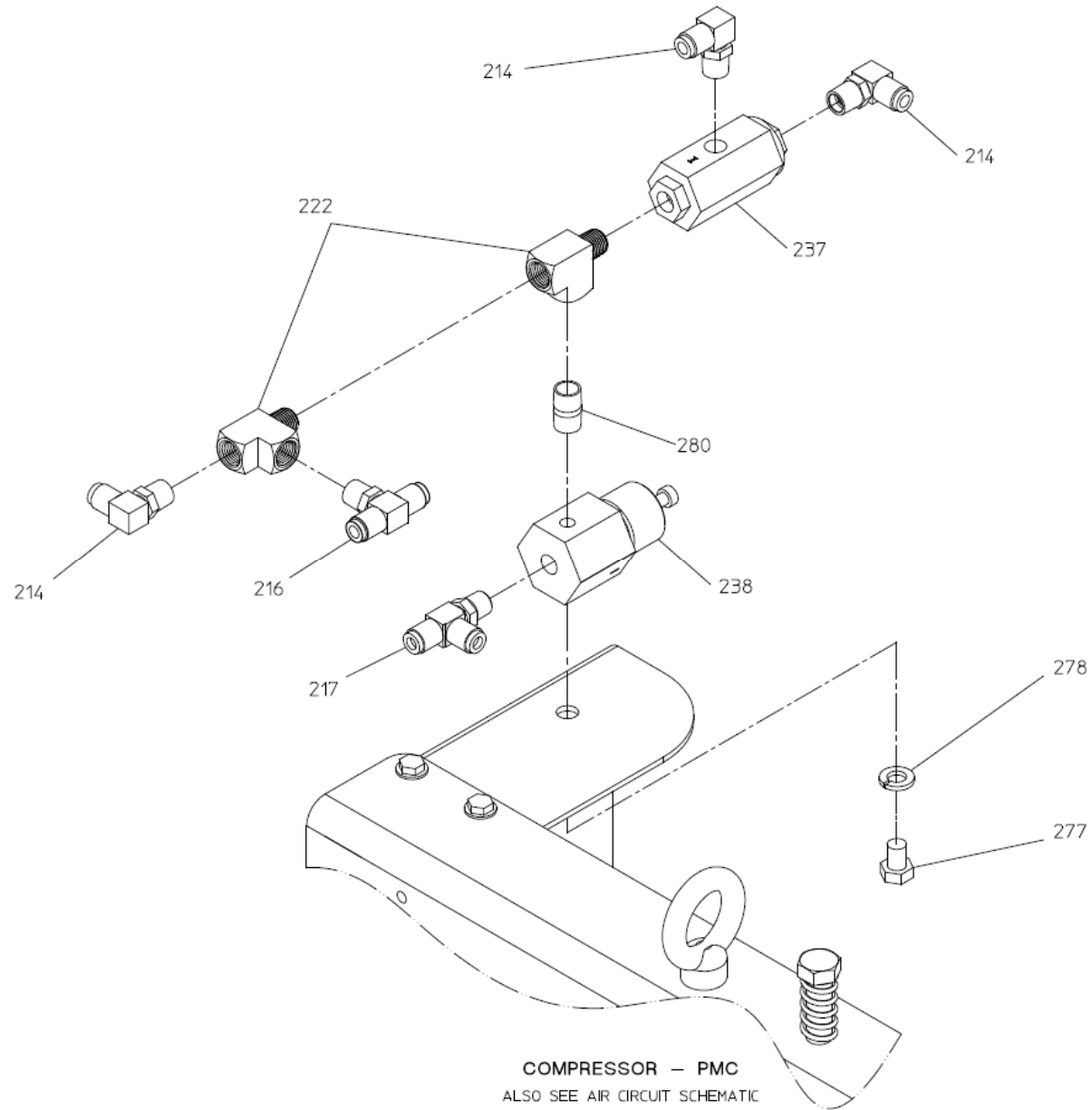

COMPRESSOR - PMC  
ALSO SEE AIR CIRCUIT SCHEMATIC

## Compressor – Balance Valve

REF NO.	DESCRIPTION
205	90 Deg. Trim Valve, 1/8 MNPT x 1/4 AB
207	Reducing Bushing, 1/2 NPT x 1/8 NPT
211	Straight Adapter, 1/4 MNPT x 1/4 AB
214	90 Deg. Elbow, 1/4 MNPT x 1/4 AB
232	Balance Valve Subassembly

REF NO.	DESCRIPTION
248	Hex Hd Screw, 1/4-20
252	Flat Washer, 1/4 in.
255	Nylok Hex Nut, 1/4-20
272	Reducing Bushing, 1/2 MNPT x 1/4 FNPT
281	Internal Support Sleeve



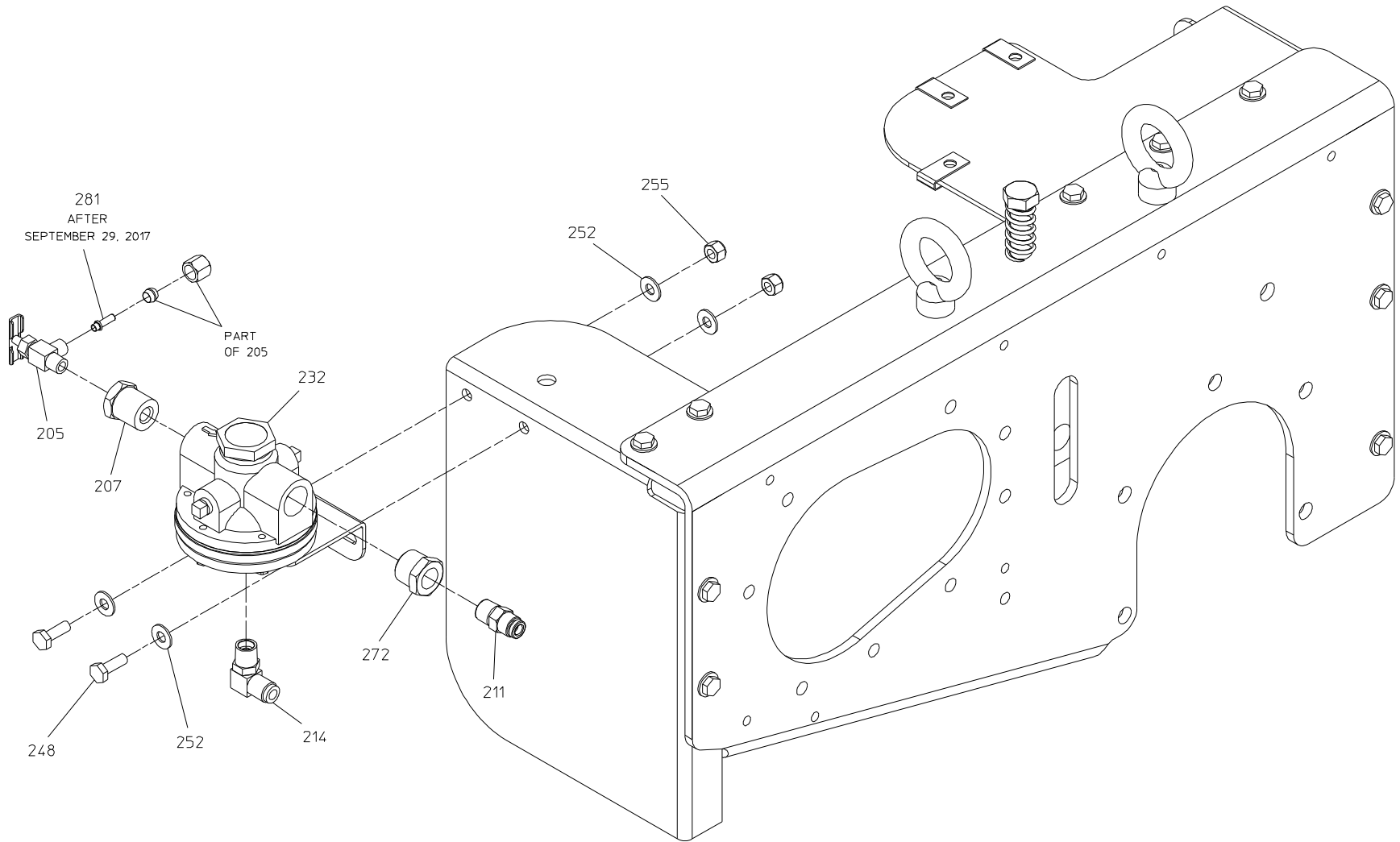

**COMPRESSOR – BALANCE VALVE**  
ALSO SEE AIR CIRCUIT AND HYDRAULIC SCHEMATIC

## Compressor – Auto-Sync

REF NO.	DESCRIPTION
208	Tee, 1/4 FNPT x 1/4 FNPT x 1/4 MNPT
211	Straight Adapter, 1/4 MNPT x 1/4 AB
214	90 Deg. Elbow, 1/4 MNPT x 1/4 AB
226	Flat Solenoid Bracket
239	Solenoid Valve

REF NO.	DESCRIPTION
248	Hex Hd Screw, 1/4-20 x 3/4 in.
252	Flat Washer, 1/4 in.
253	Flat Hd Screw, No. 10-32 x 1/2 in.
263	Red Air Brake Tube, 1/4 x 24 (Cut to Suit Installation)

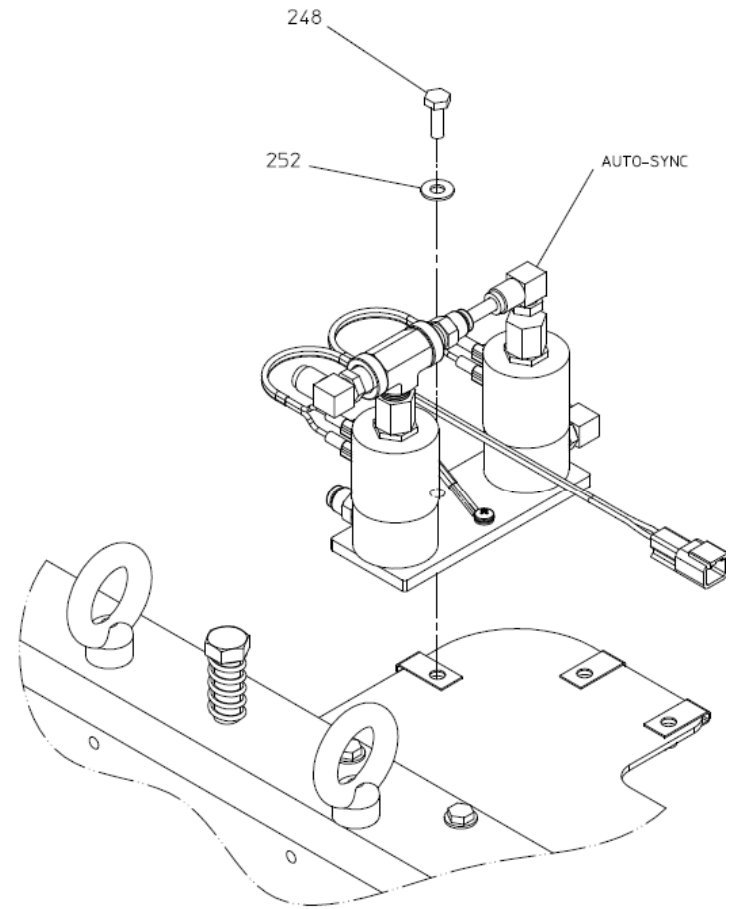
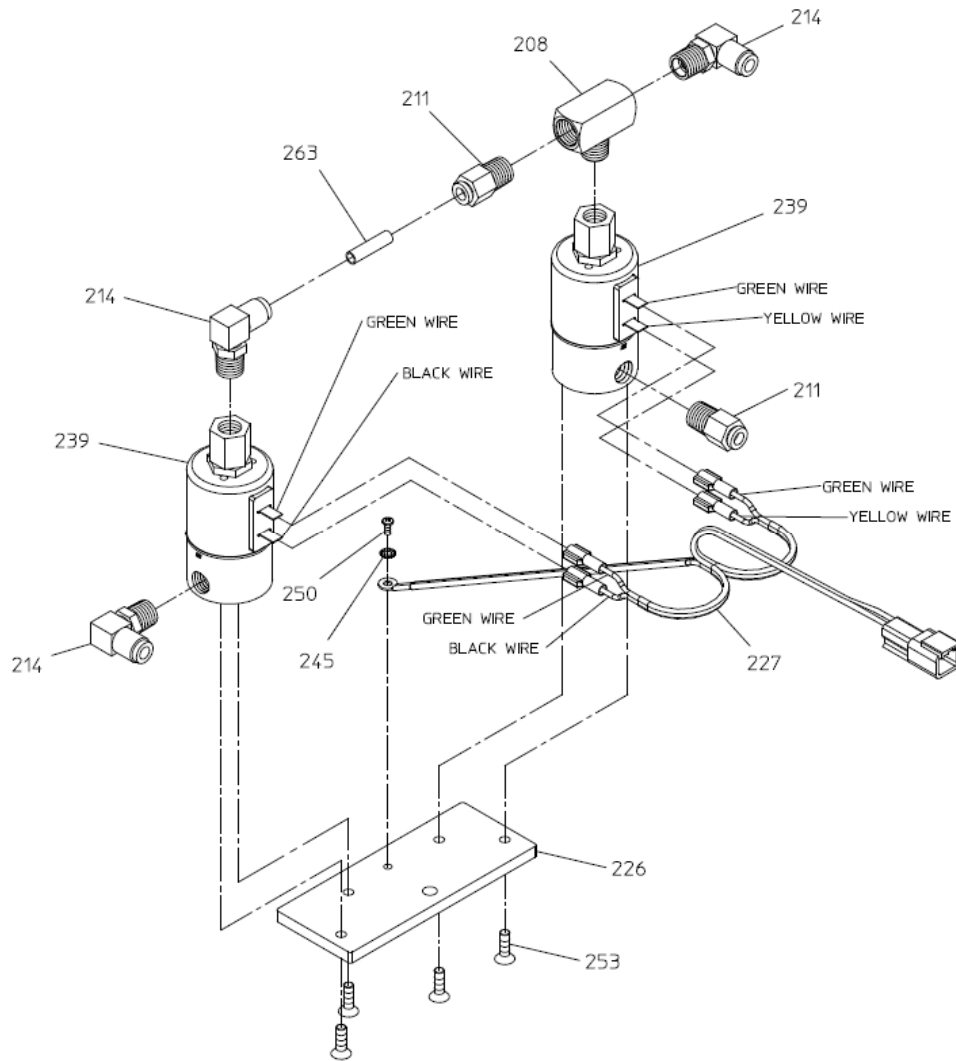

COMPRESSOR – AUTO-SYNC  
ALSO SEE AIR CIRCUIT SCHEMATIC

## Sump

REF NO.	DESCRIPTION
73	Temperature Sender
500	Sump Subassembly (Includes 501 – 513)
501	Vertical Sump, 10 in.
502	90 Deg. Street Elbow, 1/2 NPT
503	Pop Off Valve, 1/2 in.
504	Straight Adapter, 24 MJIC x 1-1/2 MNPT
505	Cap with Chain, 1 in. NPSH
506	Nipple, 1-1/2 in. NPT x 1 in. NPSH

REF NO.	DESCRIPTION
507	Sight Glass, 1-1/2 in.
512	Hex Hd Plug, 1/2 in. NPT
513	Straight Adapter, 1/2 MNPT x 8 MJIC

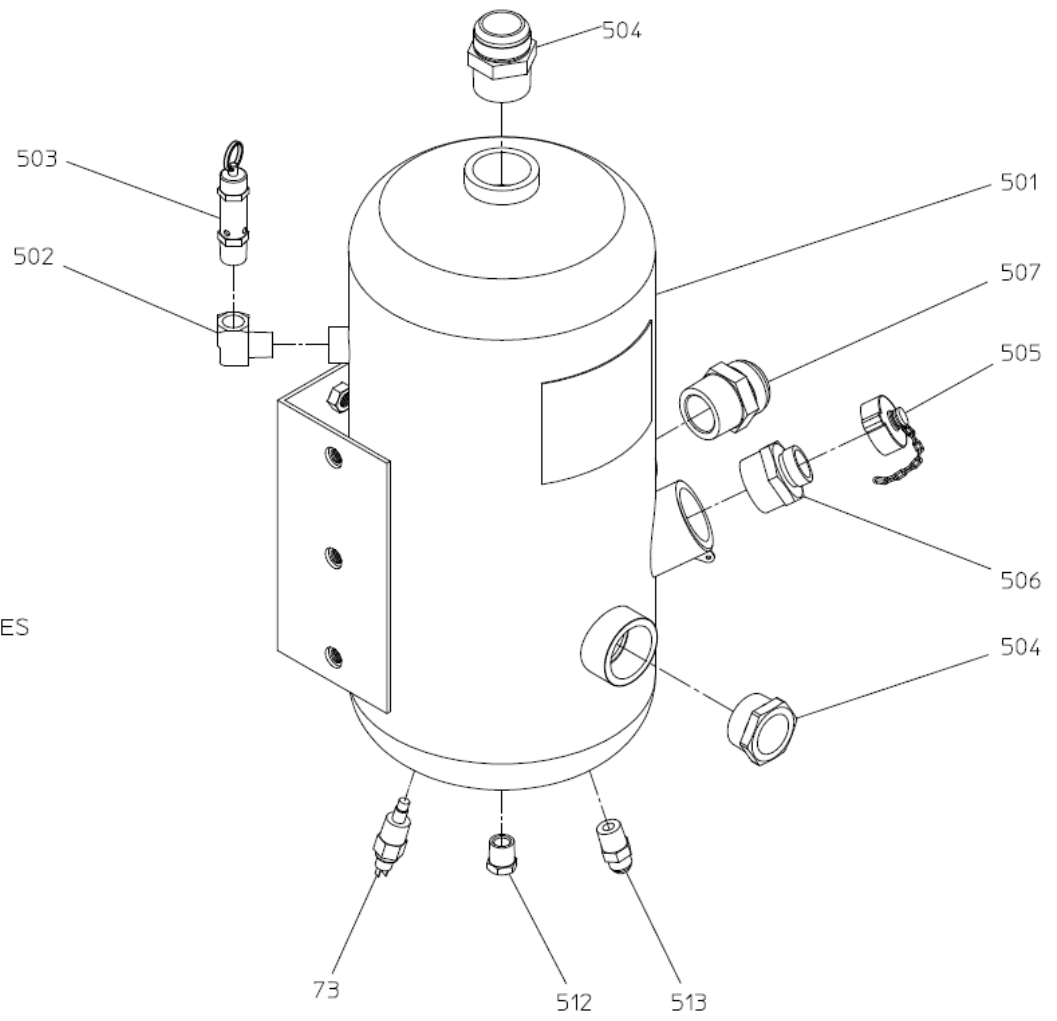

SEE HYDRAULIC SCHEMATIC FOR HOSES

SUMP  
SUB-ASS'Y

500  
(INCLUDES 501-513)

**SUMP**  
ALSO SEE HYDRAULIC SCHEMATIC

## Separator Filter

REF NO.	DESCRIPTION
600	Separator Filter Subassembly (Includes 601 – 620)
601	Scavenger Fitting
602	Straight Adapter, 24 MJIC x 1-1/4 BSP
604	Large Separator Bracket
605	Scavenger Tube Ass'y
606	Restrictor Fitting, 5/16 in.
607	Large Filter Head
608	Large Separator Filter
609	90 Deg. Street Elbow, 1-1/4 NPT
610	Close Nipple, 3/4 in. NPT
611	Minimum Pressure Control Valve, 1-1/4 in.

REF NO.	DESCRIPTION
612	Check Valve, 3/4 in.
613	Reducing Bushing, 1-1/4 NPT x 3/4 in. NPT
614	Hex Hd Screw, M10-1.5 x 20 mm
615	Flat Washer, 10 mm
616	Tee, 1/4 FNPT x 1/4 MNPT x 1/4 FNPT
618	Copper Washer, 1.928 in. OD
619	Headless Pipe Plug, 3/8 in. NPT
620	Reducer Bushing, 3/8 NPT x 1/4 NPT
622	Check Valve Rebuild Kit, 3/4 in.
623	Minimum Pressure Control Valve Repair Kit

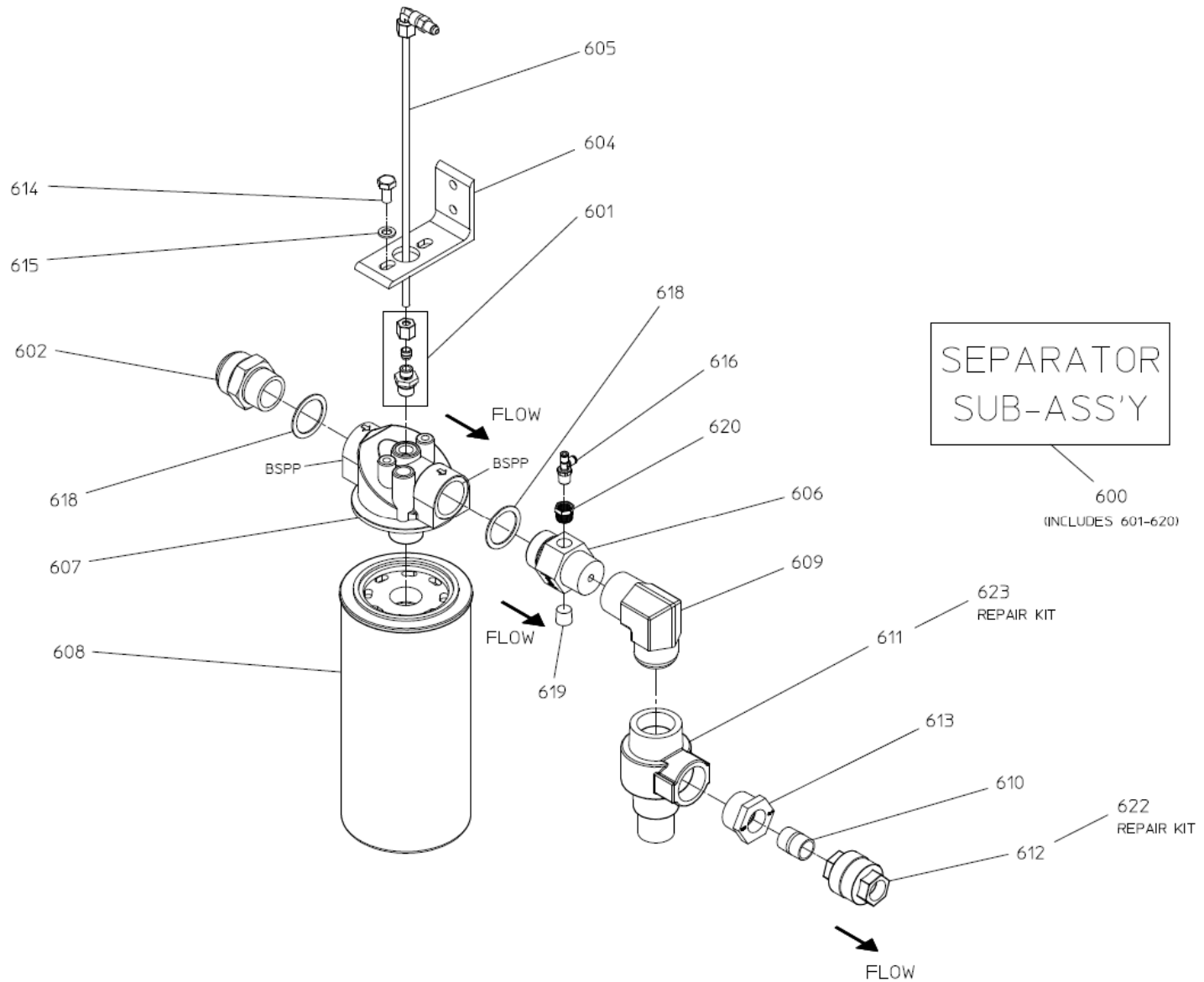

**SEPARATOR FILTER**  
ALSO SEE HYDRAULIC SCHEMATIC

**Oil Cooler and Filter**  
In-Line Strainer

REF NO.	DESCRIPTION
400	Oil Cooler Subassembly (Includes 401 – 418)
401	Pipe Nipple, 3/4 NPT x 4 in.
402	Straight Adapter, 8 MJIC x 3/4 MNPT
404	Large Filter Head
405	Oil Filter, WD962
406	Large Cooler, Iron
407	Reducing Bushing, 1-1/2 NPT x 3/4 NPT
408	Reducing Bushing, 1-1/2 NPT x 1/2 NPT

REF NO.	DESCRIPTION
409	90 Deg. Street Elbow, 3/4 NPT
410	Wye Strainer, 1 in.
411	Strainer Screen, 1 in.
412	Strainer Gasket, 1 in.
413	Pipe Nipple, 1 in. NPT x 3 in.
415	Ball Valve, 1/2 FNPT x MNPT
418	Straight Adapter, 8 MJIC x 1/2 MNPT



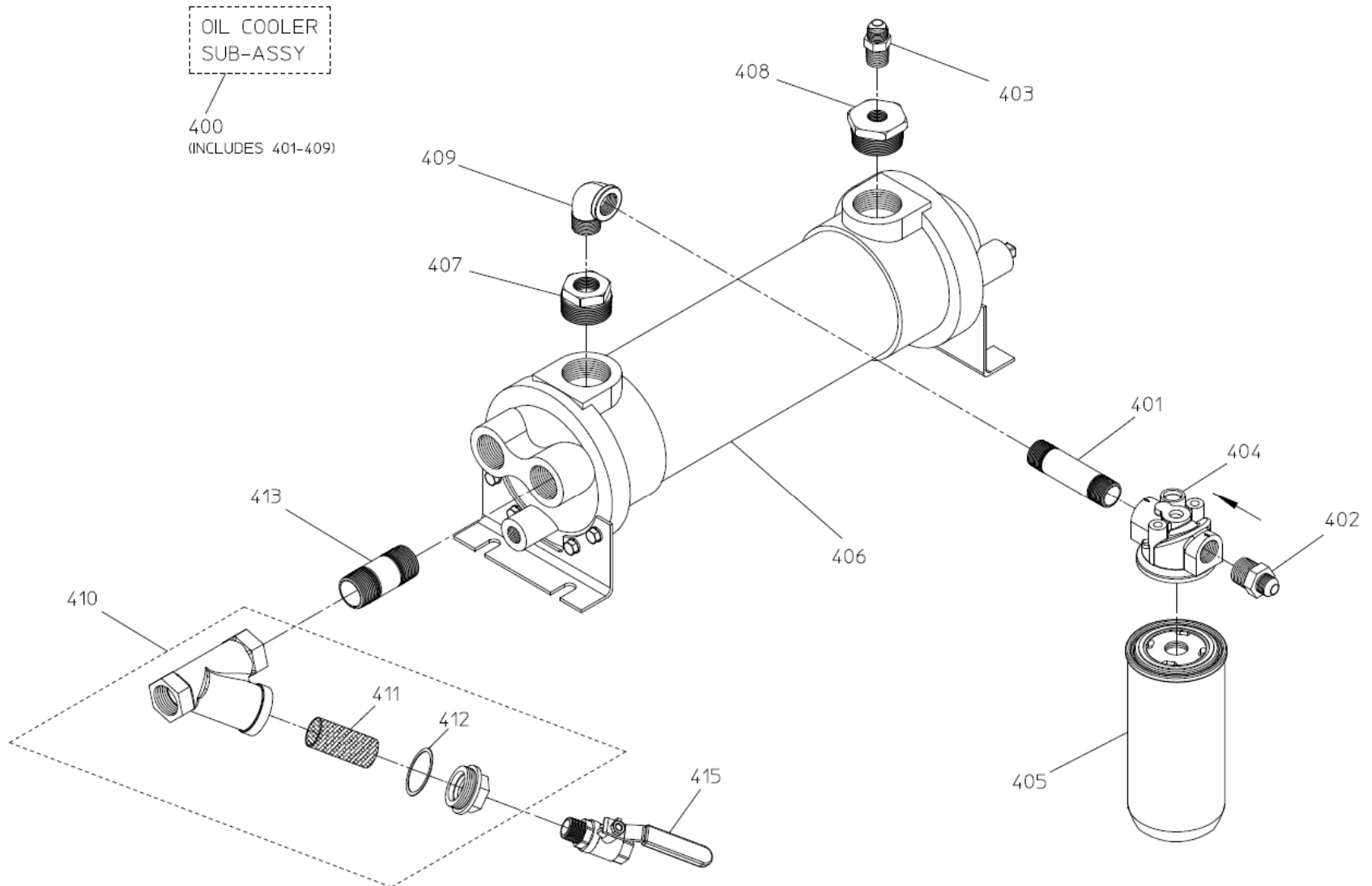

**OIL COOLER AND FILTER**  
 IN-LINE STRAINER  
 ALSO SEE HYDRAULIC SCHEMATIC

## Oil Cooler and Filter

### Panel Strainer

REF NO.	DESCRIPTION
400	Oil Cooler Subassembly (Includes 401 – 418)
401	Pipe Nipple, 3/4 NPT x 4 in.
402	Straight Adapter, 8 MJIC x 3/4 MNPT
404	Large Filter Head
405	Oil Filter, WD962
406	Large Cooler, Iron
407	Reducing Bushing, 1-1/2 NPT x 3/4 NPT
408	Reducing Bushing, 1-1/2 NPT x 1/2 NPT
409	90 Deg. Street Elbow, 3/4 NPT

REF NO.	DESCRIPTION
418	Straight Adapter, 8 MJIC x 1/2 MNPT
450	Panel Strainer Subassembly (Includes 451 – 456)
451	Panel Mounted Strainer, 20 Mesh
452	90 Deg. Elbow, 1/2 MNPT x 1/2 AB
453	Reducing Bushing, 1 MNPT x 1/2 FNPT
454	Headless Plug, 1 NPT
455	Headless Plug, 1/4 NPT
456	Straight Adapter, 1/2 MNPT x 1/2 AB

OIL COOLER  
SUB-ASS'Y

400  
(INCLUDES 401-418)

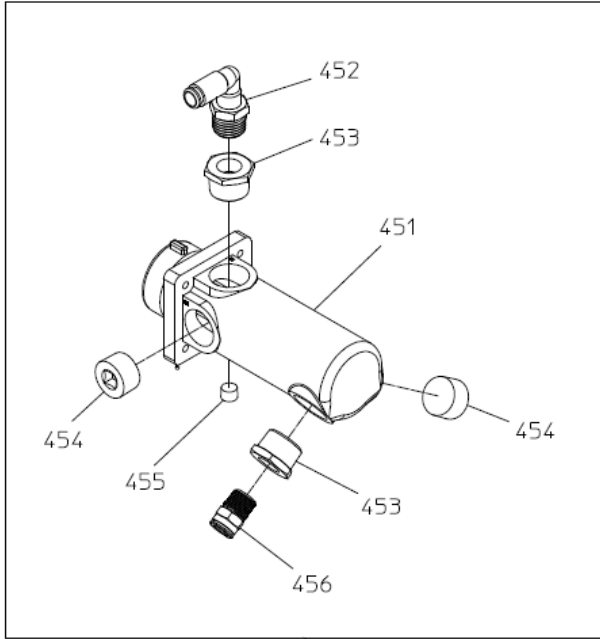
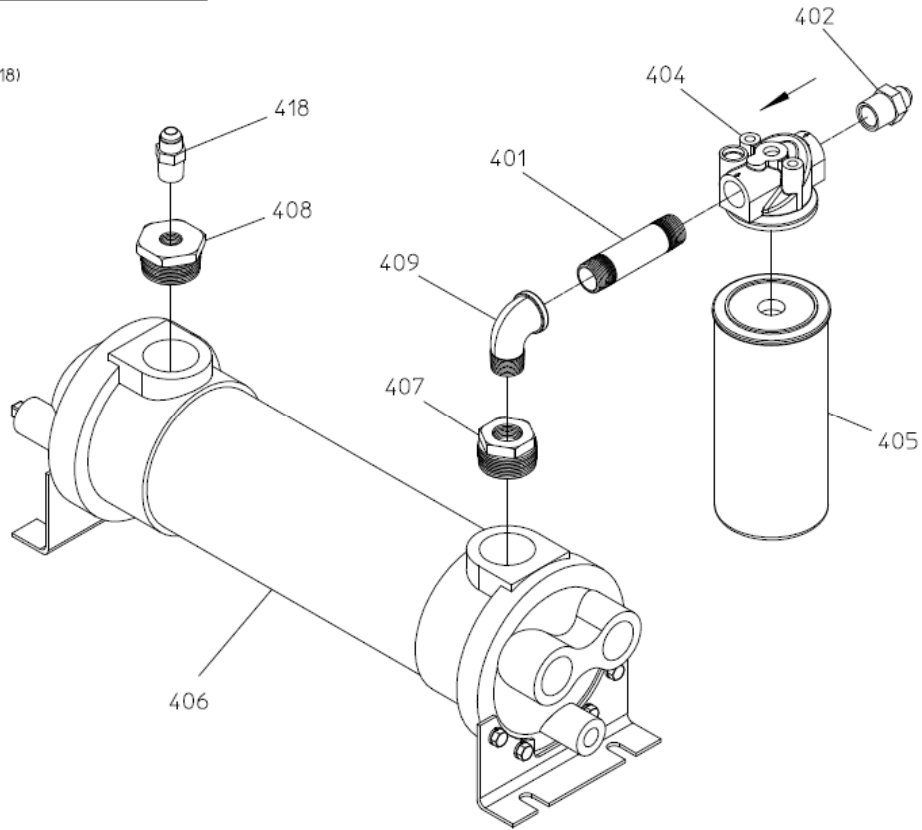

OIL COOLER AND FILTER  
PANEL STRAINER  
ALSO SEE HYDRAULIC SCHEMATIC

### Schematic – Air Circuit

REF NO.	DESCRIPTION
76	Black Air Tube, 1/4 in. x 24 in. (Cut to Suit Installation)
263	Red Air Brake Tube, 1/4 in. x 24 in. (Cut to Suit Installation)
267	Blue Air Brake Tube, 1/4 in. x 24 in. (Cut to Suit Installation)
268	Yellow Air Brake Tube, 1/4 in. x 24 in. (Cut to Suit Installation)

REF NO.	DESCRIPTION
269	Green Air Brake Tube, 1/4 in. x 24 in. (Cut to Suit Installation)
270	Black Air Brake Tube, 1/4 in. x 24 in. (Cut to Suit Installation)



## Hydraulic Schematic

### In-Line Strainer

REF NO.	DESCRIPTION
200	Compressor Subassembly
400	Oil Cooler Subassembly
500	Sump Subassembly

REF NO.	DESCRIPTION
600	Separator Subassembly
800	Balance Valve Subassembly
850	See Air Manifold Service Parts List

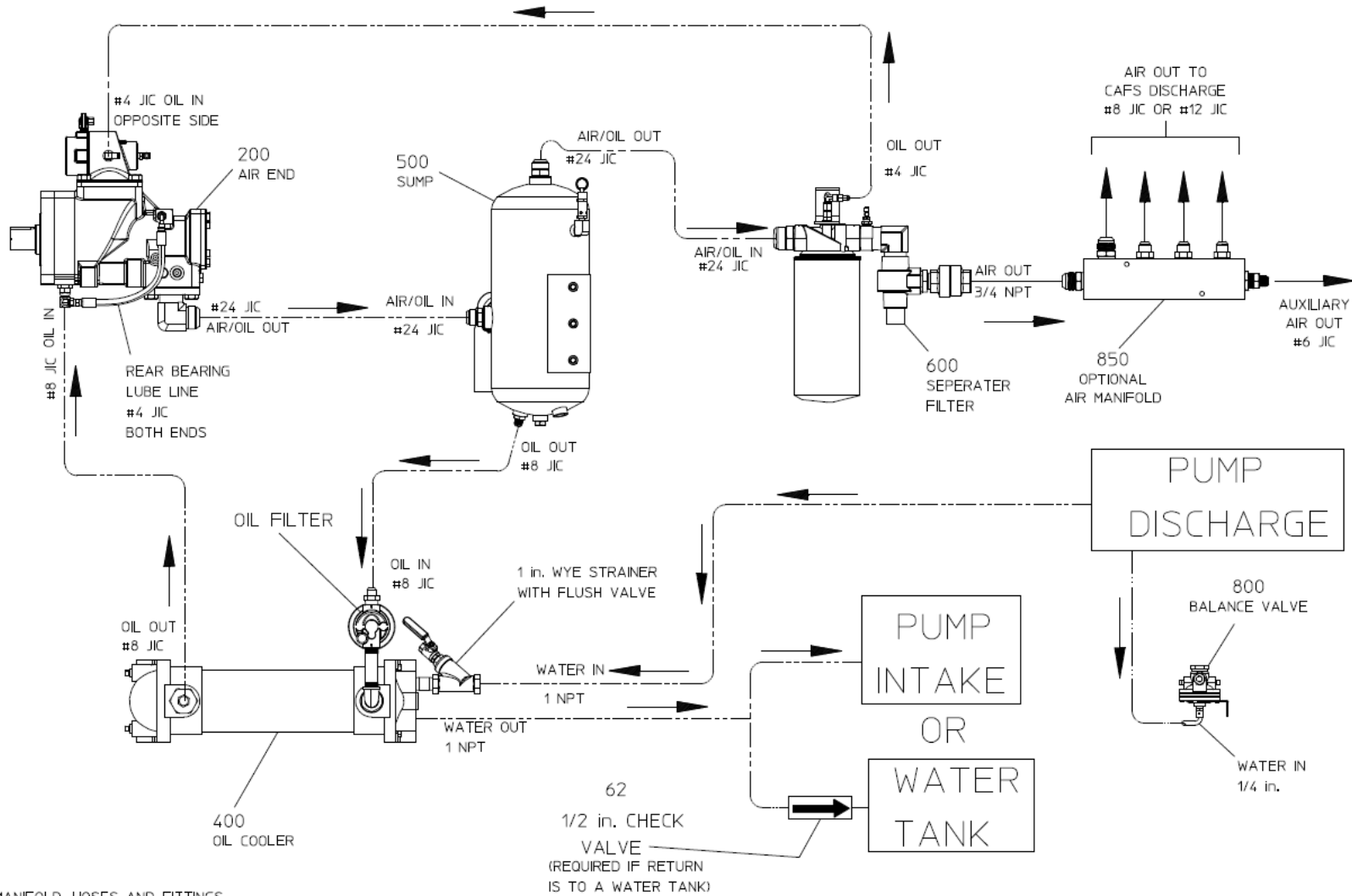

NOTE: AIR MANIFOLD, HOSES AND FITTINGS ARE OPTIONAL FROM WATEROUS. MAY HAVE BEEN FURNISHED BY OEM. SEE AIR MANIFOLD AND HOSE AND FITTING KIT PARTS LIST.

HYDRAULIC SCHEMATIC  
IN-LINE STRAINER

## Hydraulic Schematic

### Panel Strainer

REF NO.	DESCRIPTION
200	Compressor Subassembly
400	Oil Cooler Subassembly
450	Panel Strainer Subassembly
500	Sump Subassembly

REF NO.	DESCRIPTION
600	Separator Subassembly
800	Balance Valve Subassembly
850	See Air Manifold Service Parts List



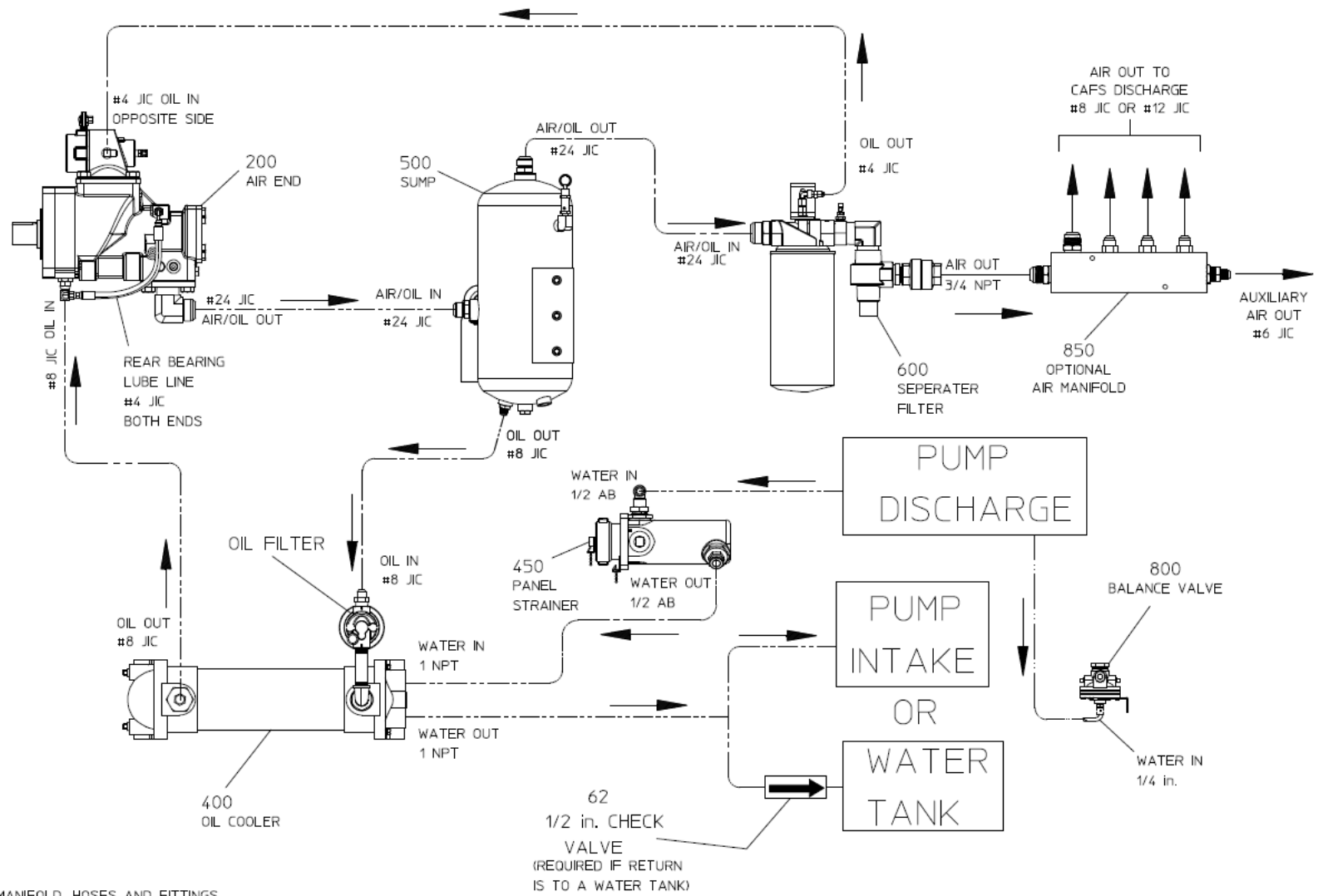

NOTE: AIR MANIFOLD, HOSES AND FITTINGS ARE OPTIONAL FROM WATEROUS. MAY HAVE BEEN FURNISHED BY OEM. SEE AIR MANIFOLD AND HOSE AND FITTING KIT PARTS LIST.

HYDRAULIC SCHEMATIC  
PANEL STRAINER

## Schematic - Electrical

REF NO.	DESCRIPTION
1	Auto-Sync Panel Plate
23	Electric Auto-Sync Switch Harness
72	Dual Scale Oil Temperature Gauge
73	Temperature Sender (Sump)

REF NO.	DESCRIPTION
75	Auto-Sync Extension Harness
227	Electric Auto-Sync Wiring Harness
239	Solenoid Valve

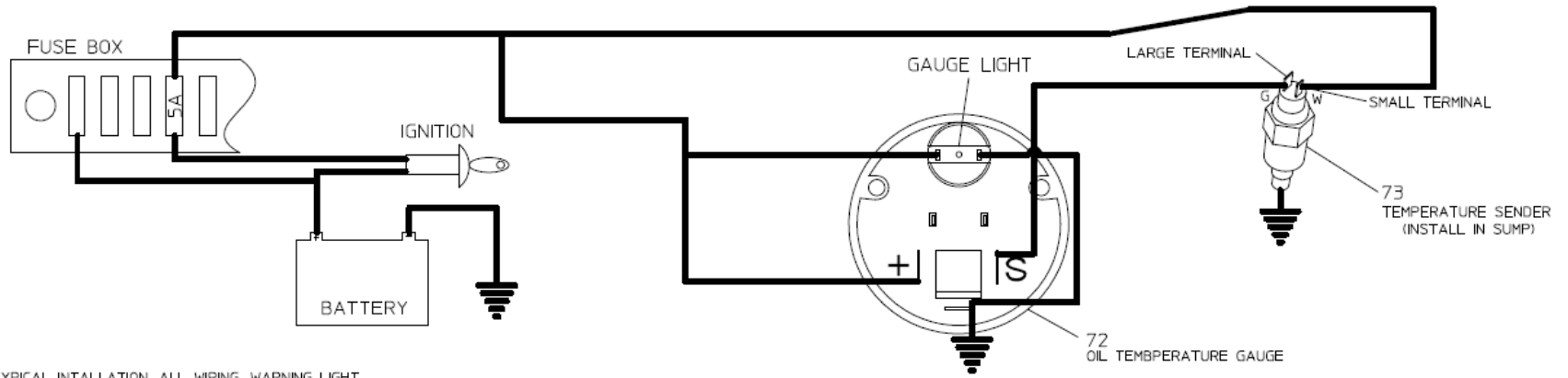

NOTE: TYPICAL INTALLATION, ALL WIRING, WARNING LIGHT, FUSE, IGNITION SWITCH AND BATTERY FURNISHED BY OEM

SUMP TEMPERATURE SENDER AND OIL TEMPERATURE GAUGE

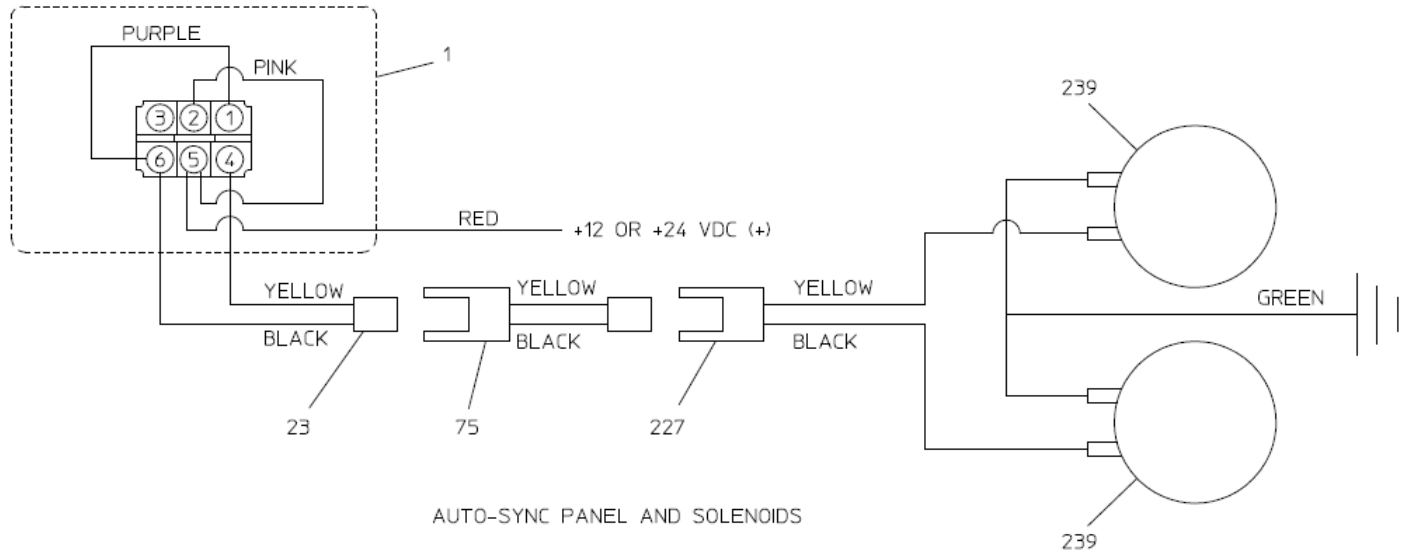

AUTO-SYNC PANEL AND SOLENOIDS

SCHEMATIC - ELECTRICAL

## Panel Components

REF NO.	DESCRIPTION
1	Auto-Sync Panel Plate
23	Electric Auto-Sync Switch Harness
70	CAFS Warning Panel Plate

REF NO.	DESCRIPTION
71	Hose Length Panel Plate
72	Dual Scale Oil Temperature Gauge
74	Oil Temperature Gauge Conversion Kit to 24V

