

E500 Series Motor Pump Services Parts List

Index:

See Pages				
Pump Model		Mounting on Engine	Engine	Instrument Panel
E501-C	E511-C			
2-5	6-9	10,11	12,13	14,15

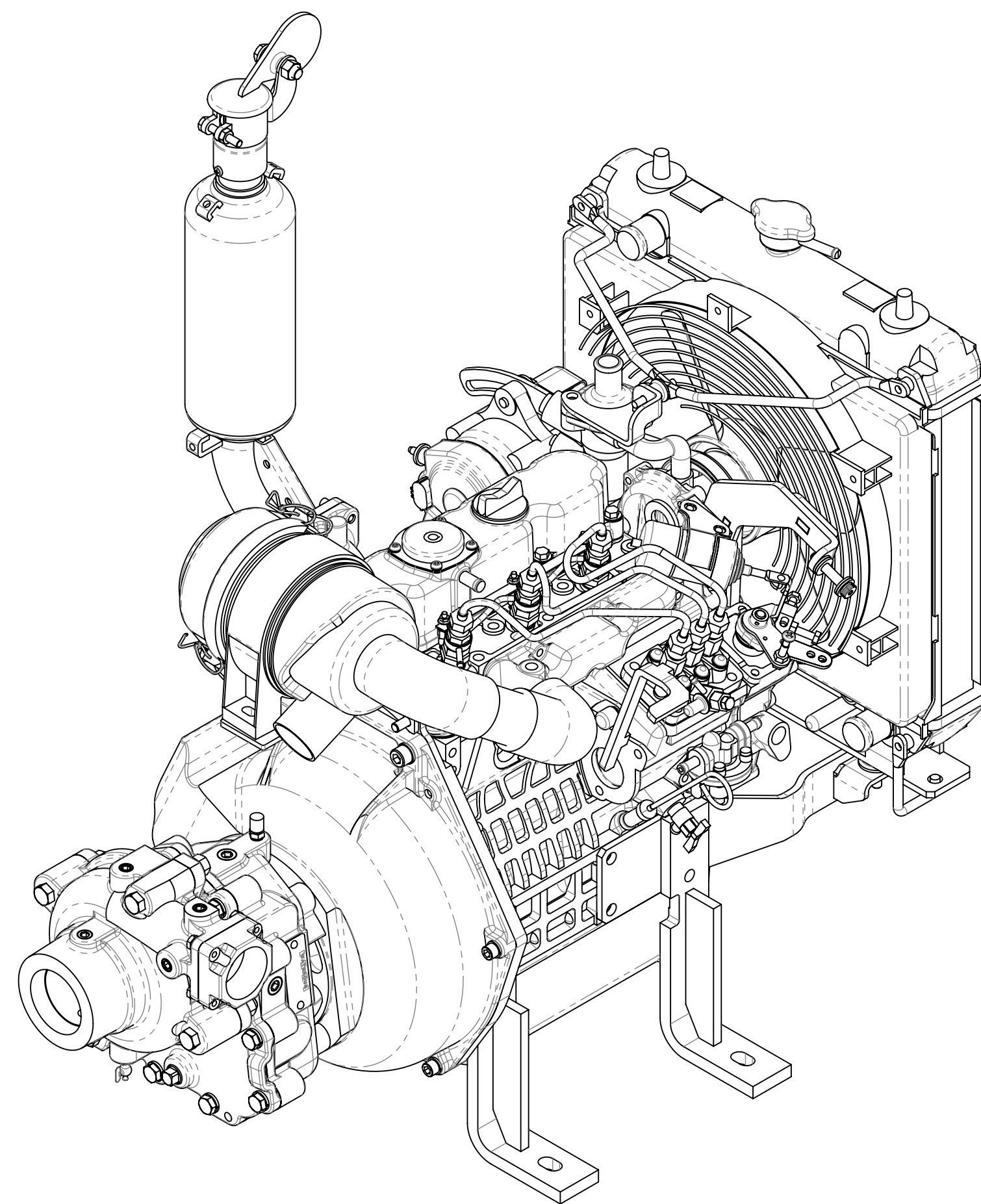

Model E501-C

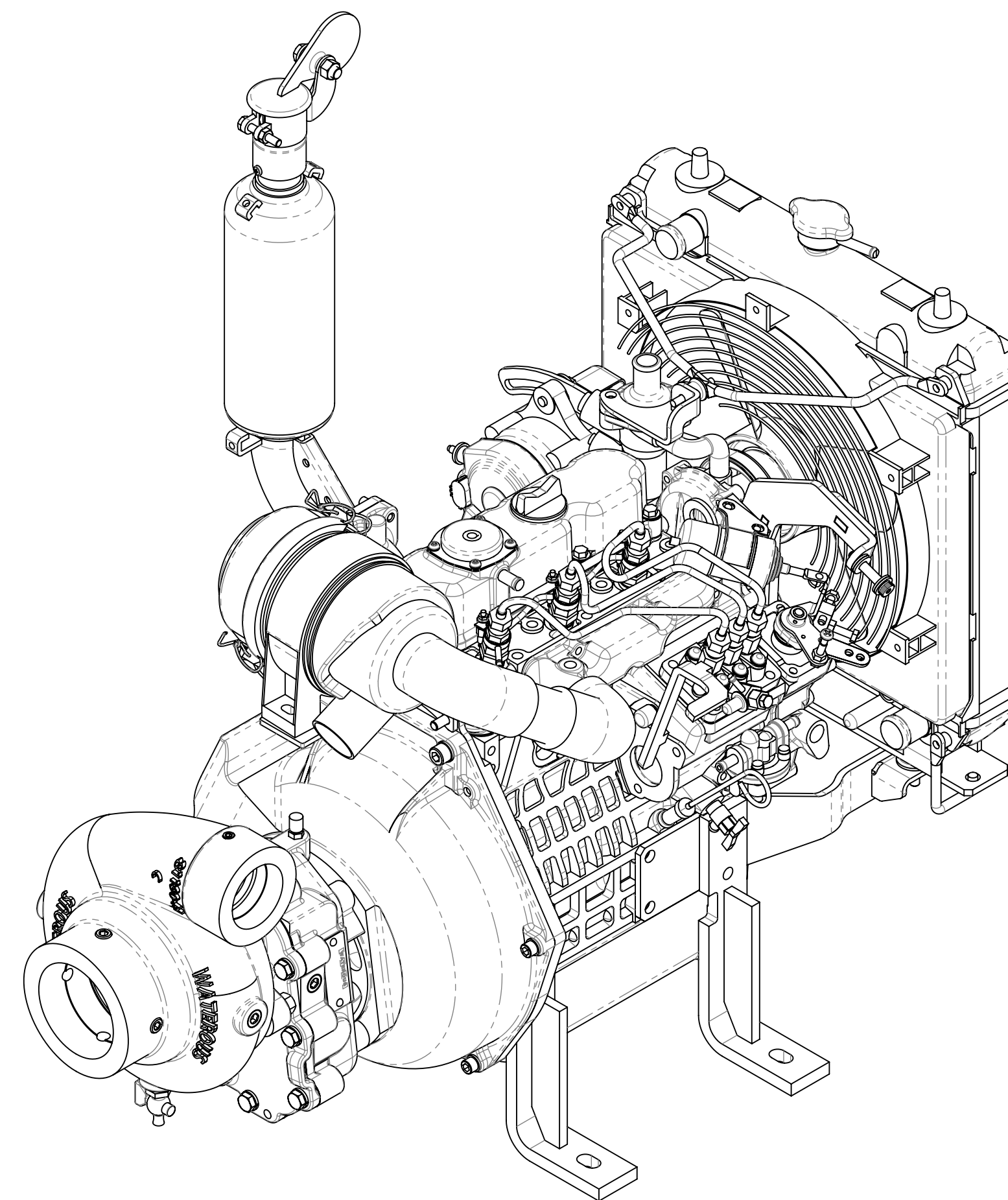

Model E511-C

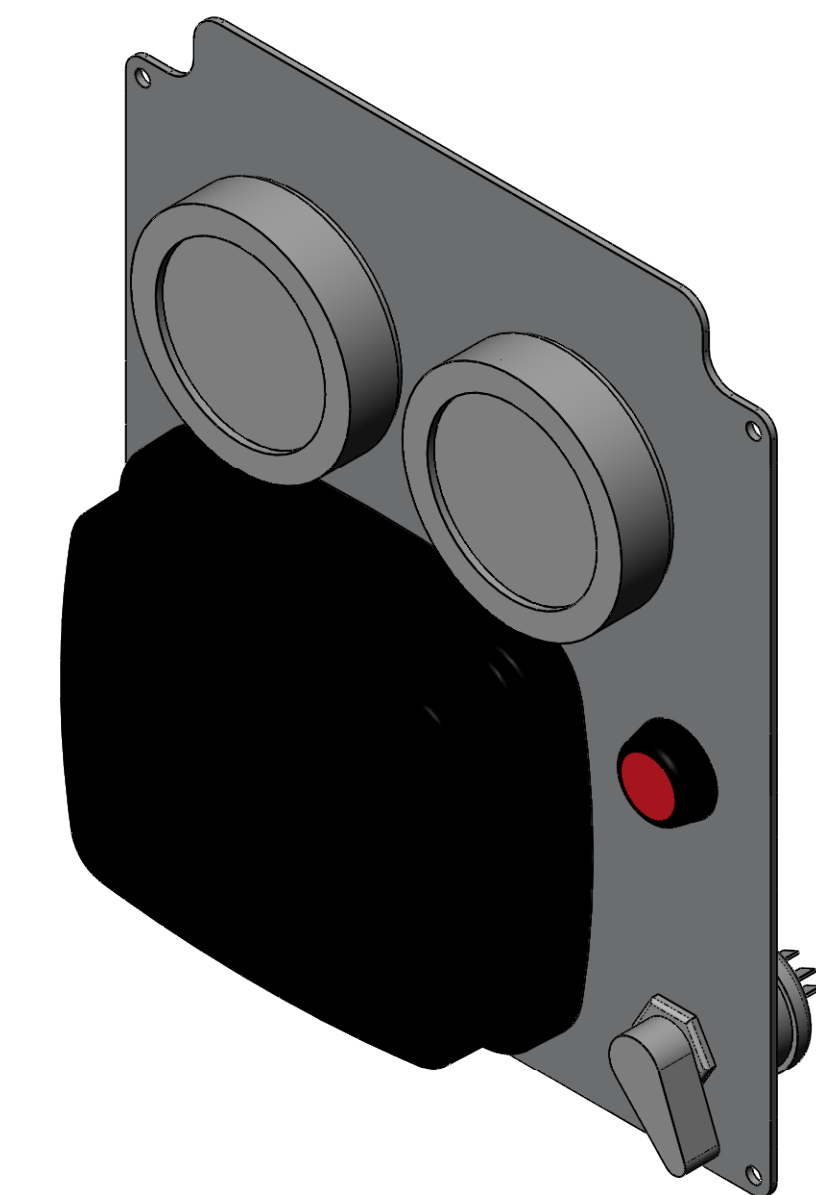

Instrument Panel

E501 Pump

Ref. No.	Description
21	Hex Hd Screw, 7/16-20 x 3 in.
22	Hex Hd Screw, 7/16-20 x 2-3/4 in.
23	Volute Body Subassembly (Includes 38, Wear Ring)
24	Pipe Plug, 1/4 in. NPT
25	Mechanical Seal
26	O-Ring, 5-3/4 x 6 in.
27	Gear Case Cover (Includes 38, Wear Ring)
28	Lock Washer, 7/16 in.
29	Hex Nut, 7/16-20
30	Oil Seal
31	Ball Bearing
33	Drive Shaft/Gear
34	Drain Cock
38	Wear Ring
39	Hex Nut, 1/2-20
40	Washer, Nord-Lock, 1/2 in.
41	Impeller
42	Square Key, 3/16 x 1 in (Prior to January 1, 2023)
42	Square Key, 3/16 x 5/8 in (After January 1, 2023)
43	Magnetic Pipe Plug, 3/8 in., NPT
44	Hex Hd Screw, 3/8-16 x 1 in.
45	Lock Washer, 3/8 in.
46	Gear Case Gasket

Ref. No.	Description
47	Ball Bearing
49	Chamfered Square Key, 1/4 x 1-1/8 in.
52	Drive Screw, #6 x 1/4 in.
54	Pipe Plug, 3/8 in. NPT
55	Gear Case
56	Drive Gear
57	Oil Seal
59	Dowel Pin, 5/16 x 3/4 in. SS
60	Flat Washer, 3/8 in. Copper
61	Serial Plate
64	Breather
103	Spacer
121	Socket Hd Screw, 3/8-16 x 1-3/4
123	1-1/2 in. NPT (F) Discharge Adapter
124	O-Ring, 2-1/8 x 1-15/16 in.
125	Hex Hd Screw, 1/4-20 x 3/4 in.
126	Hex Nut - Thin Nylok, 1-14
127	Impeller Gasket (Prior to January 1, 2023)
144	Retaining Ring
151	O-Ring, 7/16 x 9/16 in (After January 1, 2023)

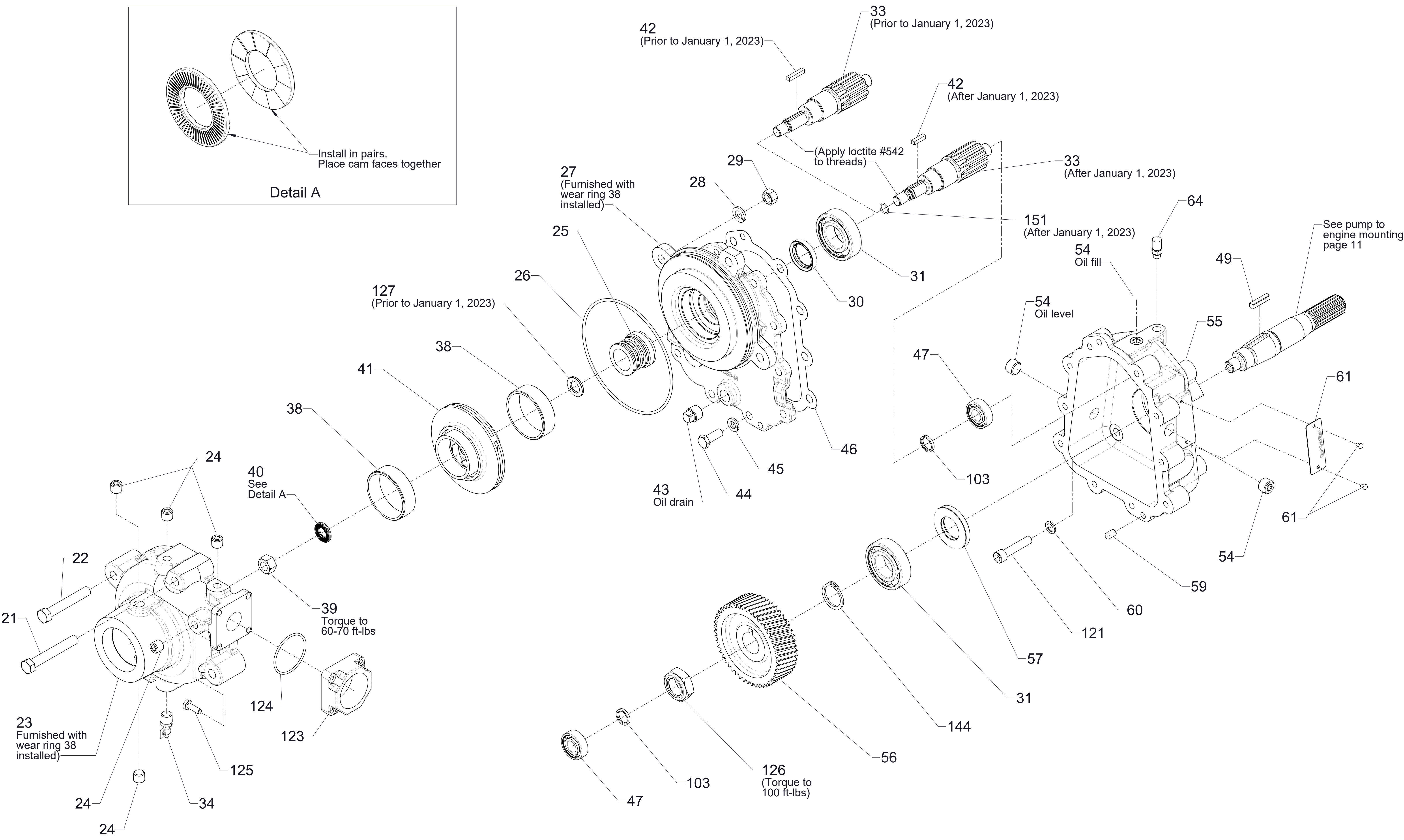
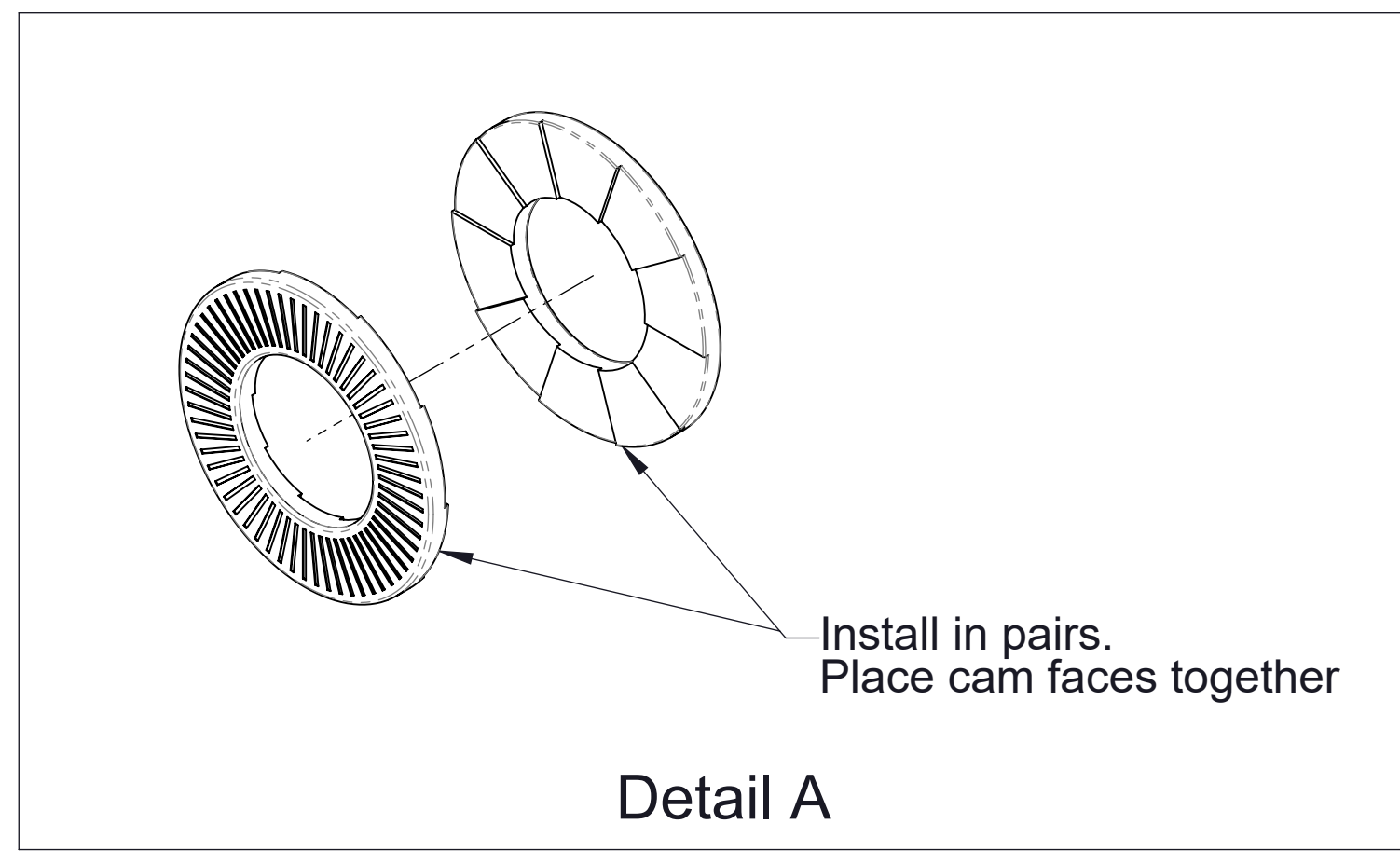

E501-C Pump
See page 5 for sectional view

E501 Pump Sectional View

Ref. No.	Description
21	Hex Hd Screw, 7/16-20 x 3 in.
22	Hex Hd Screw, 7/16-20 x 2-3/4 in.
23	Volute Body Subassembly (Includes 38, Wear Ring)
24	Pipe Plug, 1/4 in. NPT
25	Mechanical Seal
26	O-Ring, 5-3/4 x 6 in.
27	Gear Case Cover (Includes 38, Wear Ring)
28	Lock Washer, 7/16 in.
29	Hex Nut, 7/16-20
30	Oil Seal
31	Ball Bearing
33	Driven Shaft/Gear
34	Drain Cock
38	Wear Ring
39	Hex Nut, 1/2-20
40	Nord-Lock Washer, 1/2 in.
41	Impeller
42	Square Key, 3/16 x 1 in (Prior to January 1, 2023)
42	Square Key, 3/16 x 5/8 in (After January 1, 2023)
43	Magnetic Pipe Plug, 3/8 in., NPT
44	Hex Hd Screw, 3/8-16 x 1in.
45	Lock Washer, 3/8 in.
46	Gear Case Gasket

Ref. No.	Description
47	Ball Bearing
49	Chamfered Square Key, 1/4 x 1-1/8 in.
52	Drive Screw, #6 x 1/4 in.
54	Pipe Plug, 3/8 in. NPT
55	Gear Case
56	Drive Gear
57	Oil Seal
59	Dowel Pin, 5/16 x 3/4 in. SS
60	Flat Washer, 3/8 in. Copper
61	Serial Plate
64	Breather
67	Engine Adapter
76	Drive Shaft
103	Spacer
104	Pump Sub-Assy (For Repairs Only)
121	Socket Hd Screw, 3/8-16 x 1-3/4 in.
123	Discharge Adapter, 1-1/2 in. NPT (F)
124	O-ring, 2-1/8 x 1-15/16 in.
125	Hex Hd Screw, 1/4-20 x 3/4 in.
126	Nut - Lock, 1-14
127	Impeller Gasket (Prior to January 1, 2023)
144	Retaining Ring
151	O-Ring, 7/16 x 9/16 in (After January 1, 2023)

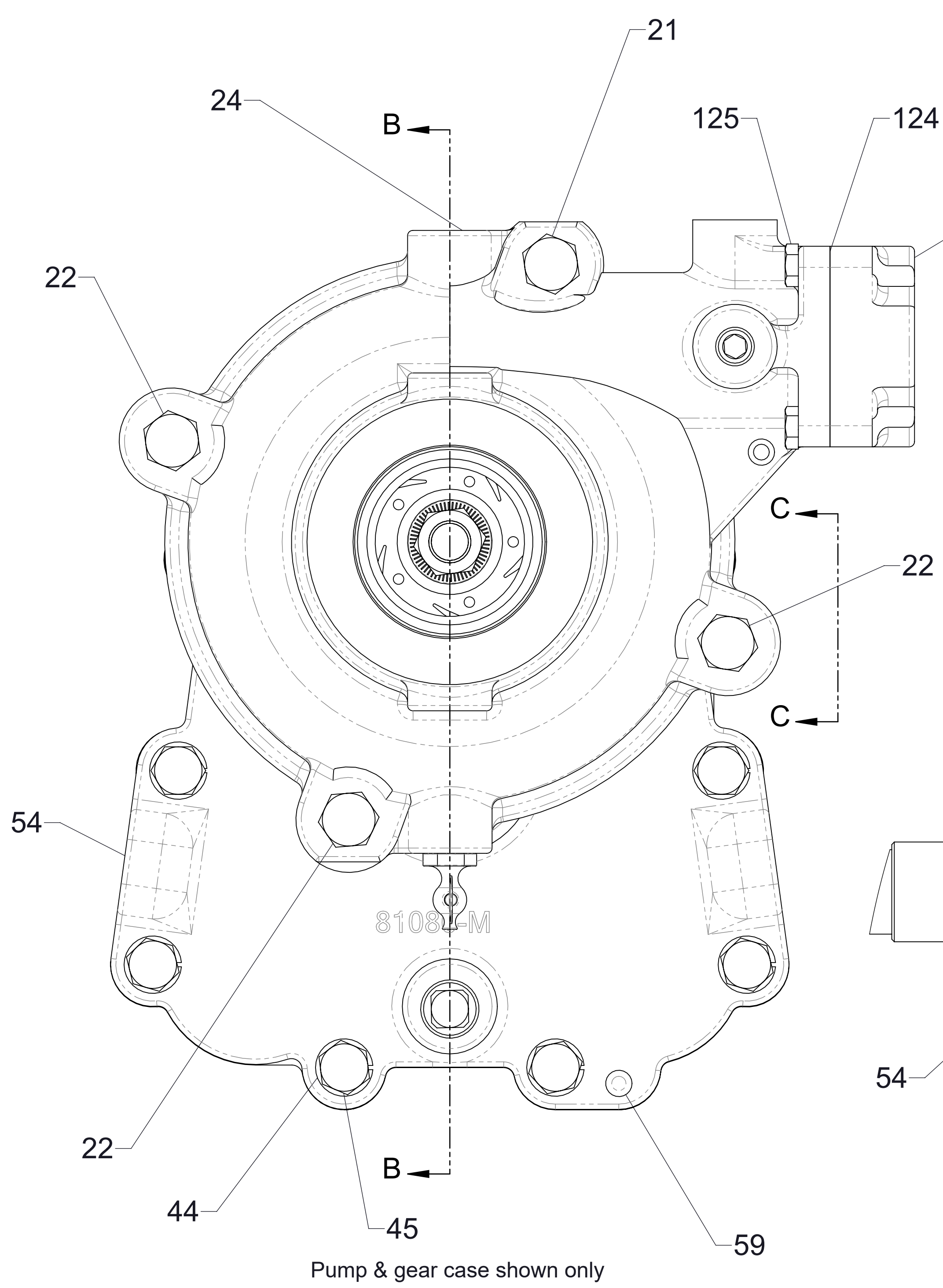

Pump & gear case shown only

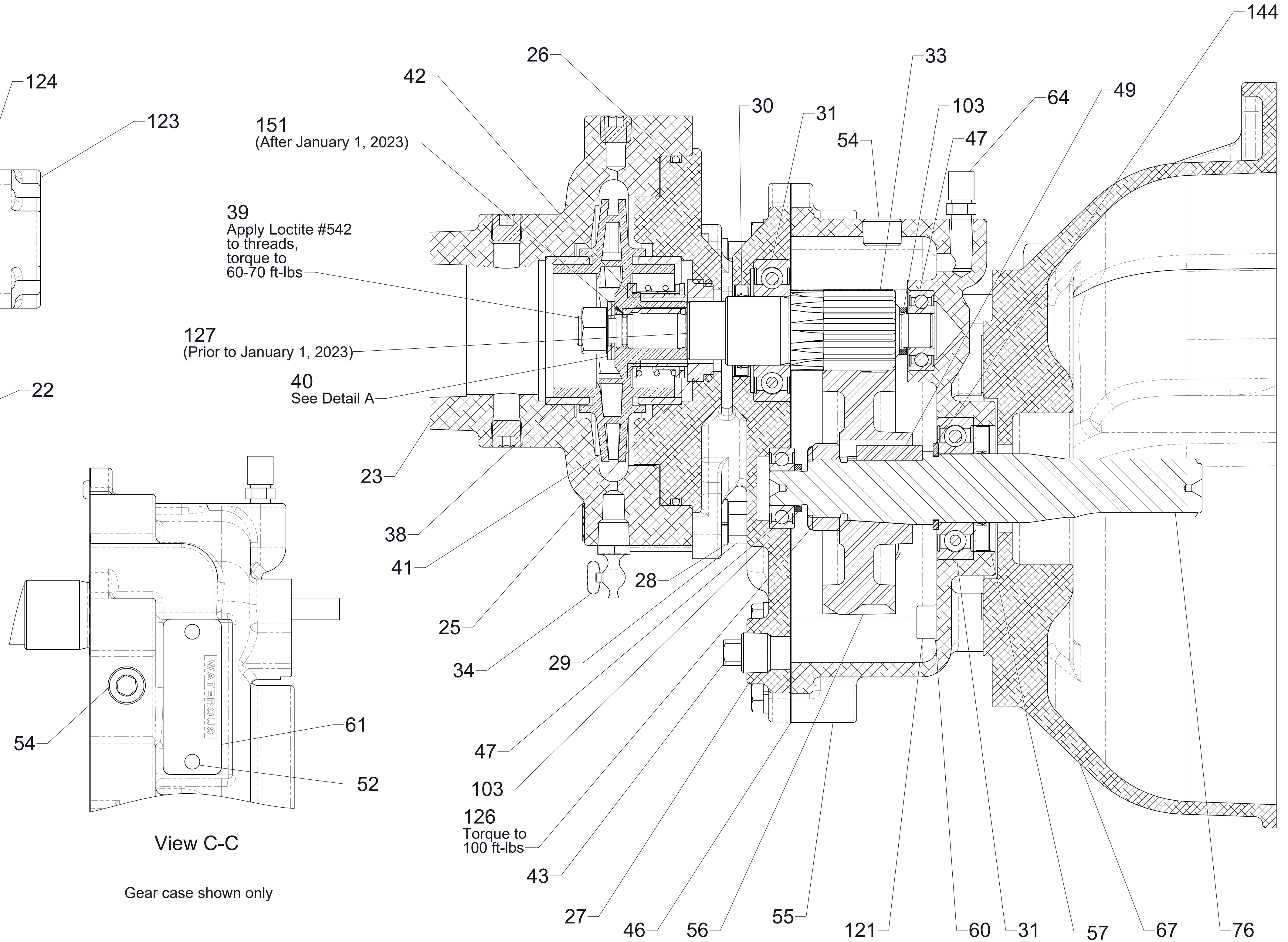

Section B-B

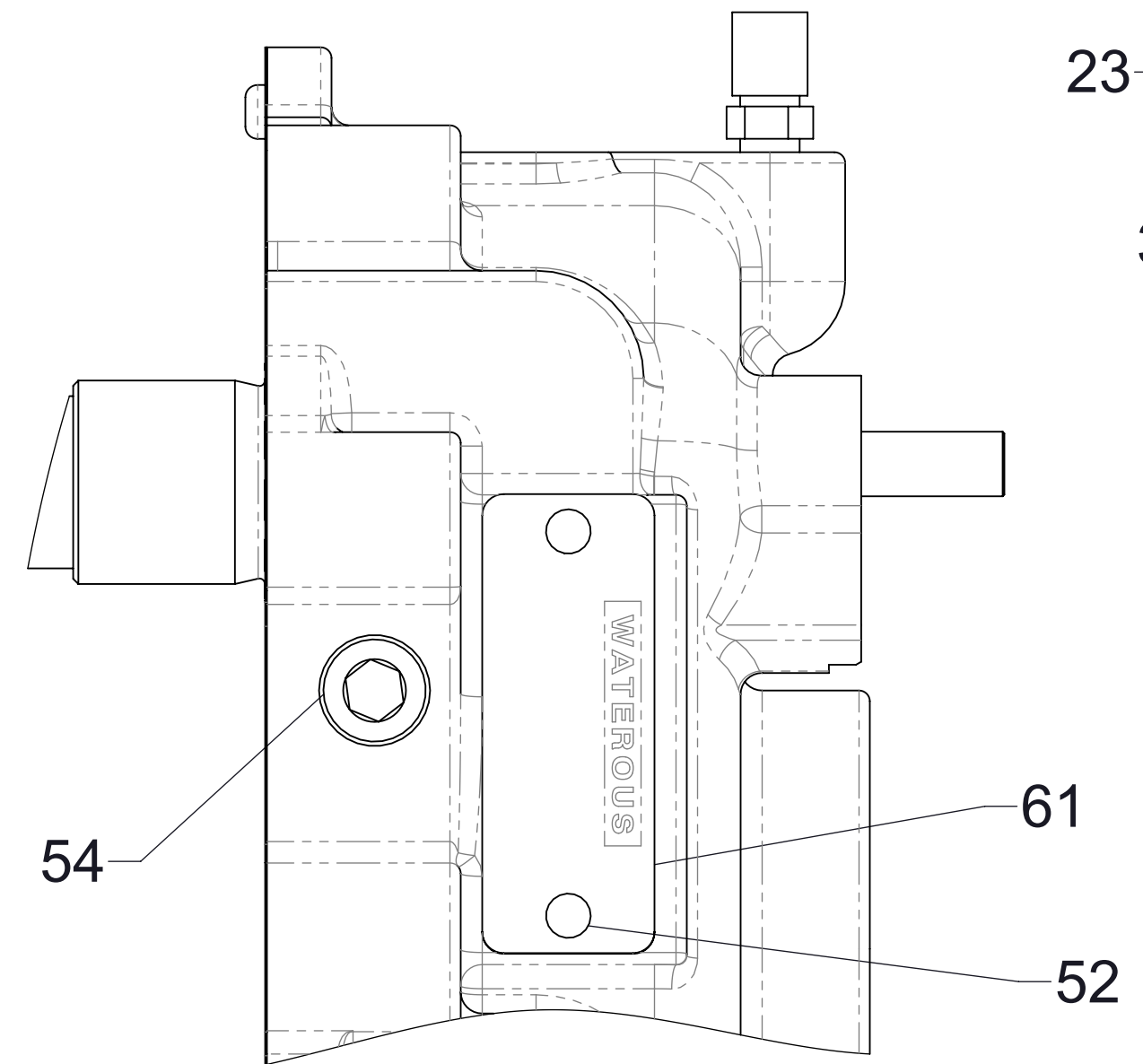

View C-C

Gear case shown only

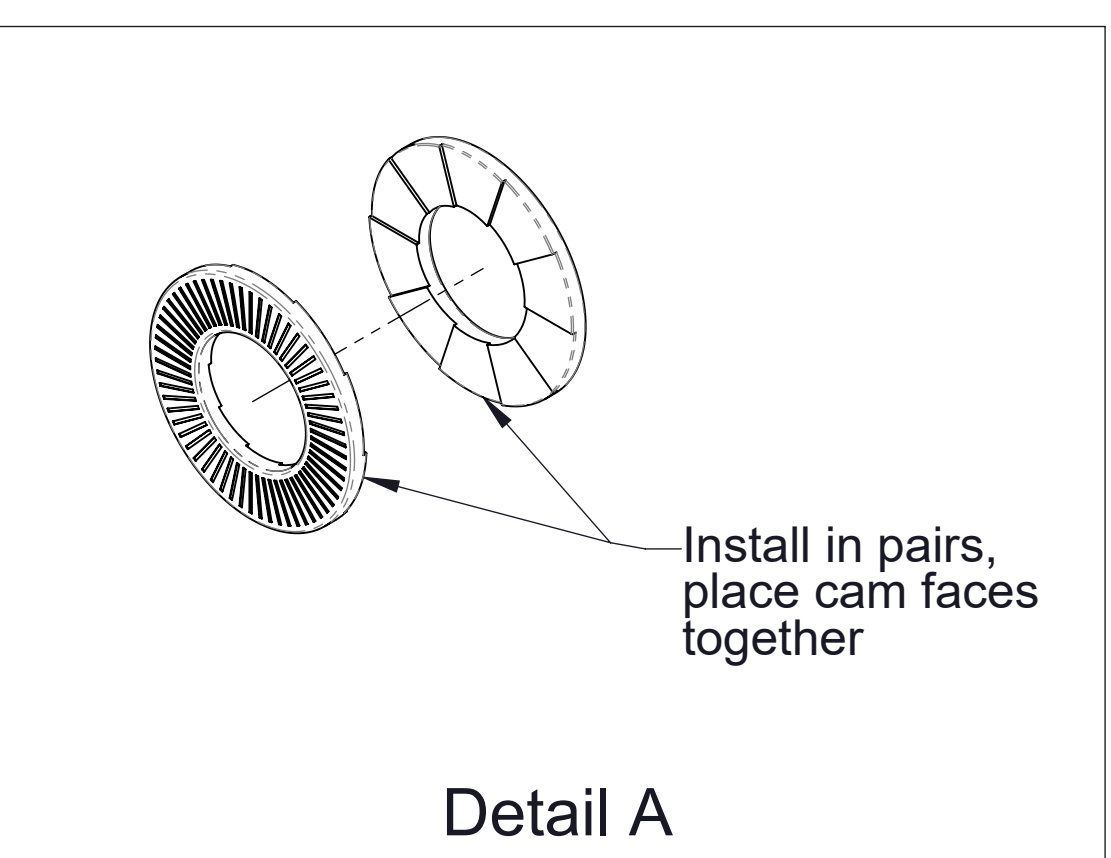

Detail A

104
Includes all components shown
Pump Sub-Assy

E501-C Sectional View
All parts shown are available as a sub-assembly Ref No. 104 (for service only)

E511 Pump

Ref. No.	Description
23	Volute Body Subassembly (Includes Pipe Plug 24, Wear Ring 38 and Stud 136)
24	Pipe Plug, 1/4 in, NPT
25	Mechanical Seal
26	O-Ring, 5-3/4 x 6
27	Gear Case Cover
28	Lock Washer, 7/16 in.
29	Hex Nut, 7-16-20
30	Oil Seal
31	Ball Bearing
33	Imperial Shaft Assembly (Includes Bearing)
34	Drain Cock
38	Wear Ring
39	Hex Nut, Thin Nylok, 3/4-16
40	Nord-Lock Washer, 3/4 in.
41	Impeller
42	Square Key, 1/4 x 1 in., SS
43	Magnetic Pipe Plug, 3/8 in., NPT
44	Hex Hd Screw ,3/8-16 x 1in.
45	Lock Washer, 3/8 in.
46	Gear Case Gasket
47	Ball Bearing

Ref. No.	Description
49	Chamfered Square Key, 1/4 x 1-1/8 in.
52	Drive Screw, #6 x 1/4 in.
54	Pipe Plug, 3/8 in. NPT
55	Gear Case
56	Drive Gear
57	Oil Seal
59	Dowel Pin, 5/16 x 3/4 in., SS
60	Flat Washer, 3/8 in., Copper
61	Serial Plate
64	Breather
103	Spacer
106	Headless Pipe Plug, 1/8 NPT
115	Retaining Ring
121	Socket Hd Screw, 3/8-16 x 1-3/4
126	Nut - Lock, 1
136	Stud, 7/16-14 x 7-16-20 x 2 in.
137	Adapter, 2in. NPT x 2 in. Victaulic (Optional)
138	Adapter, 3in. NPT x 3 in. Victaulic (Optional)
144	Retaining Ring

E511 Pump Sectional View

Ref. No.	Description
23	Volute Body Subassembly (Includes Pipe Plug 24, Wear Ring 38 and Stud 136)
24	Pipe Plug, 1/4 in, NPT
25	Mechanical Seal
26	O-Ring, 5-3/4 x 6
27	Gear Case Cover
28	Lock Washer, 7/16 in.
29	Hex Nut, 7-16-20
30	Oil Seal
31	Ball Bearing
33	Imperial Shaft Assembly (Includes Bearing)
34	Drain Cock
38	Wear Ring
39	Hex Nut, Thin Nylok, 3/4-16
40	Nord-Lock Washer, 3/4 in.
41	Impeller
42	Square Key, 1/4 x 1 in., SS
43	Magnetic Pipe Plug, 3/8 in., NPT
44	Hex Hd Screw, 3/8-16 x 1in.
45	Lock Washer, 3/8 in.
46	Gear Case Gasket
47	Ball Bearing

Ref. No.	Description
49	Chamfered Square Key, 1/4 x 1-1/8 in.
52	Drive Screw, #6 x 1/4 in.
54	Pipe Plug, 3/8 in. NPT
55	Gear Case
56	Drive Gear
57	Oil Seal
59	Dowel Pin, 5/16 x 3/4 in., SS
60	Flat Washer, 3/8 in., Copper
61	Serial Plate
64	Breather
67	Engine Adapter
76	Drive Shaft
103	Spacer
104	Pump Sub-Assy (For Repairs Only)
106	Headless Pipe Plug, 1/8 NPT
115	Retaining Ring
121	Socket Hd Screw, 3/8-16 x 1-3/4
126	Nut - Lock, 1
136	Stud, 7/16-14 x 7/16-20 x 2 in.
144	Retaining Ring

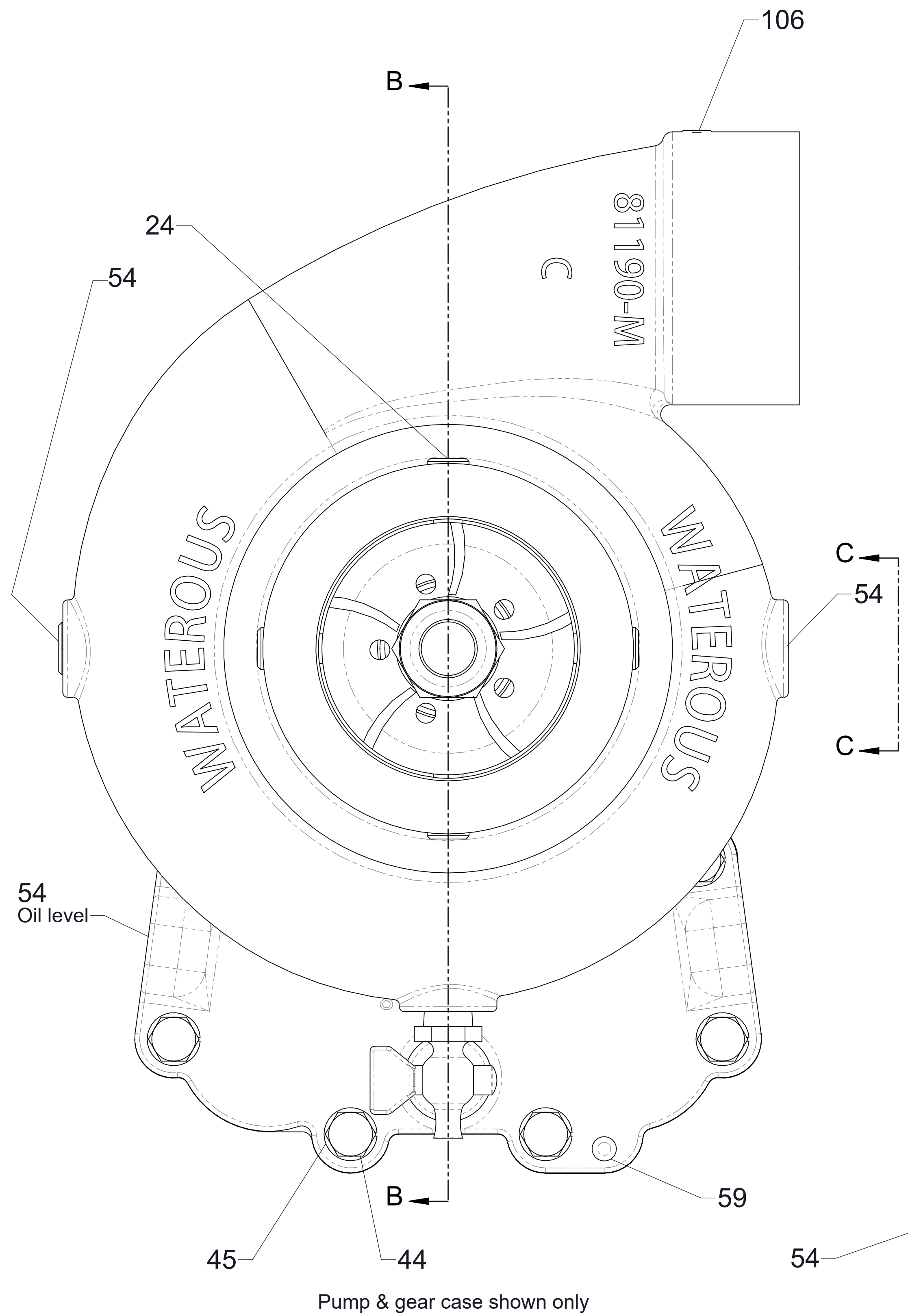

Pump Sub-Assy

104 Includes all componets shown

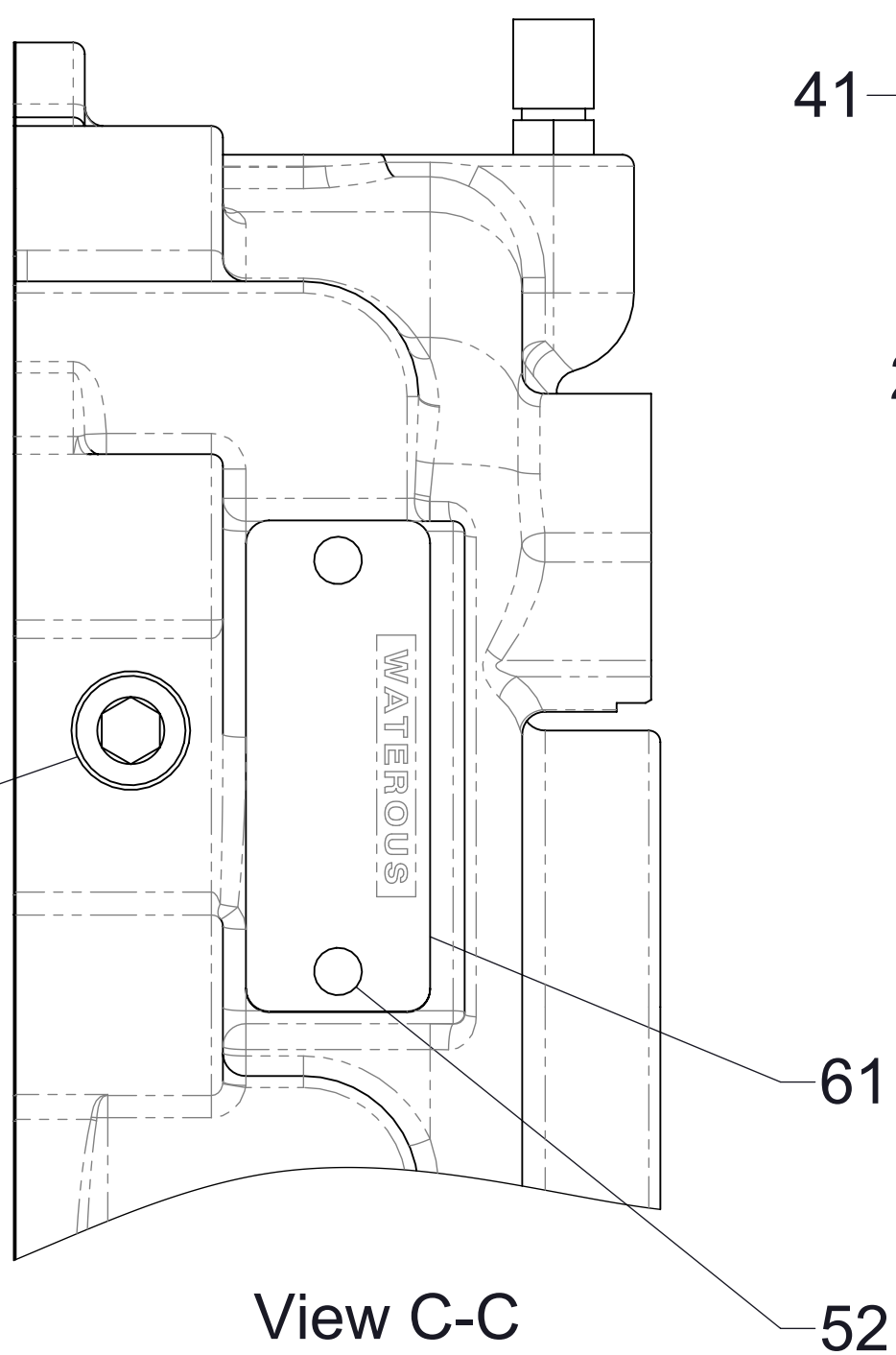
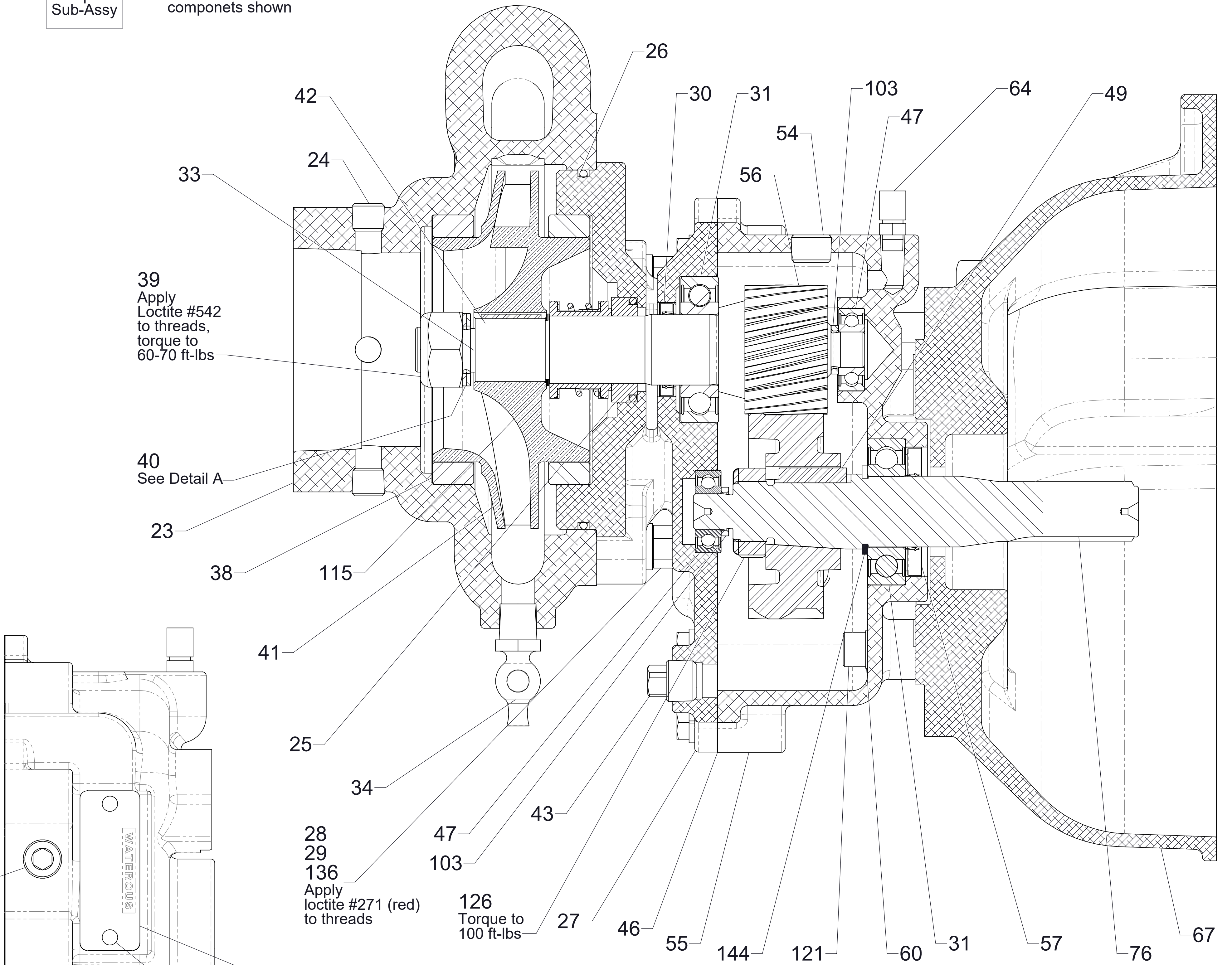

Gear case shown only

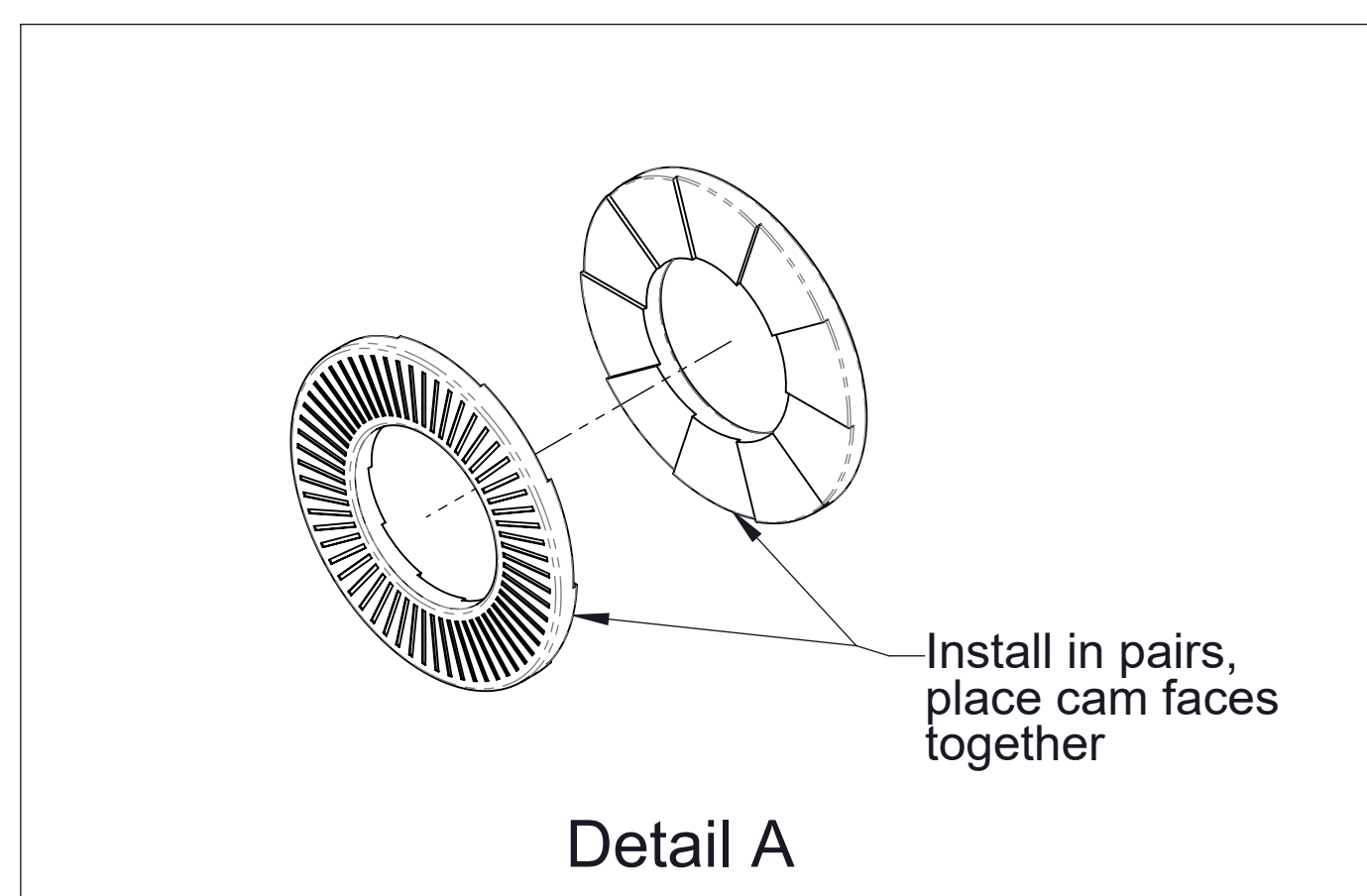

E511-C Pump Sectional View
 All parts shown are available as a sub-assembly Ref No. 104 (for service only)

Pump to Engine Mounting (All Models)

Ref. No.	Description
67	Engine Adapter
68	Soc Hd Screw, M10 - 1.25 x 30mm
69	Lock Washer, 10mm
70	Soc Hd Screw, 5/16-18 x 1-1/4 in.
71	Lock Washer, 5/16 in.
72	Soc Hd Screw, M10 - 1.25 x 25mm

Ref. No.	Description
76	Drive Shaft
77	Soc Hd Screw, M8-1.25 x 25mm
78	Lock Washer, 8mm
79	Coupling

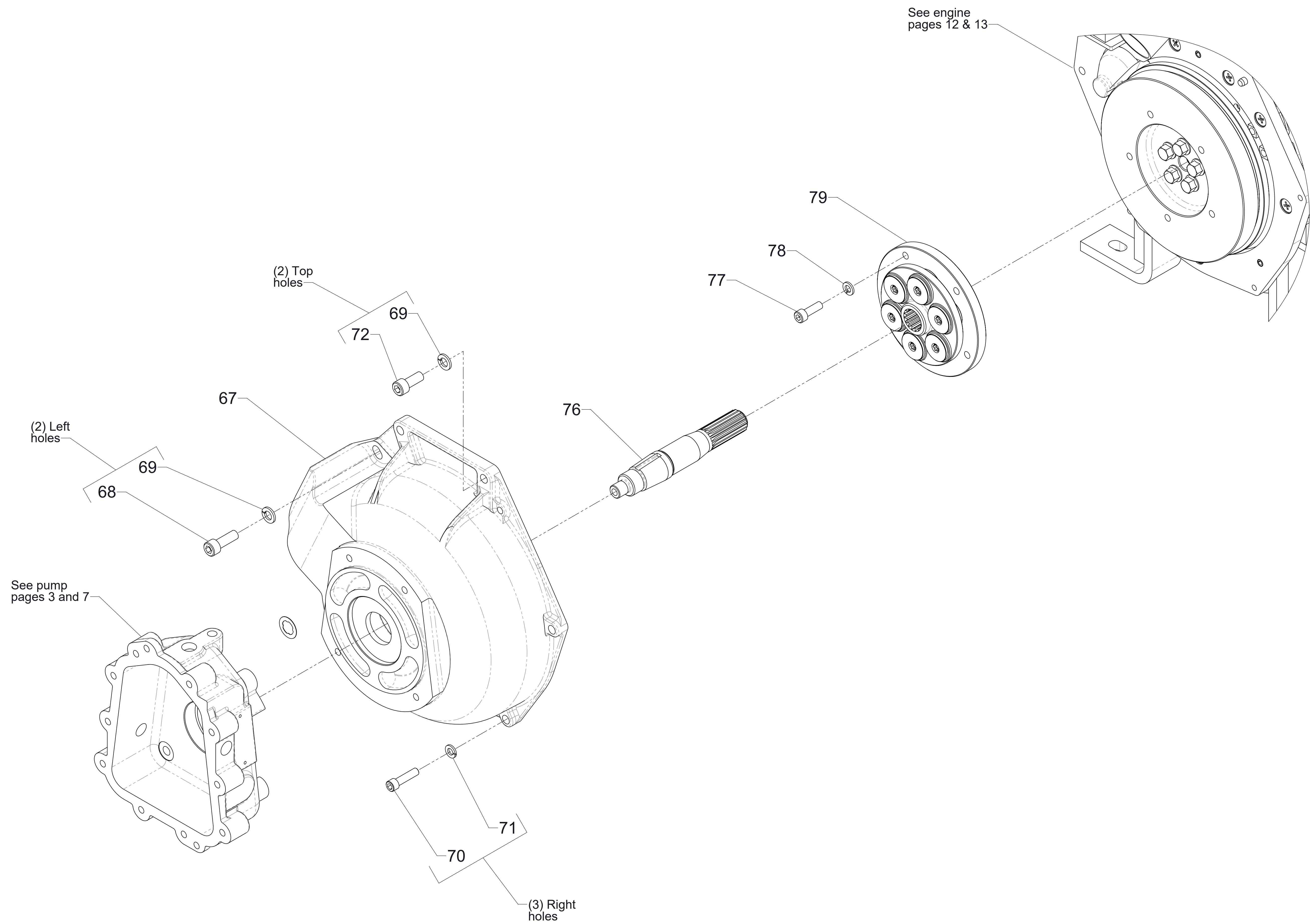

Pump to Engine Mounting
 (All models)
 See pages 5 and 9 for section view

Diesel Engine, Models E501-C & E511-C

Ref. No.	Description
82	Rain Cap
83	Diesel Engine, Kubota

Ref. No.	Description
139	Panel Serial Plate (Optional)
140	Spark Arrestor (Optional)
141	Self Tapping Screw, #8 x 1/2 in.

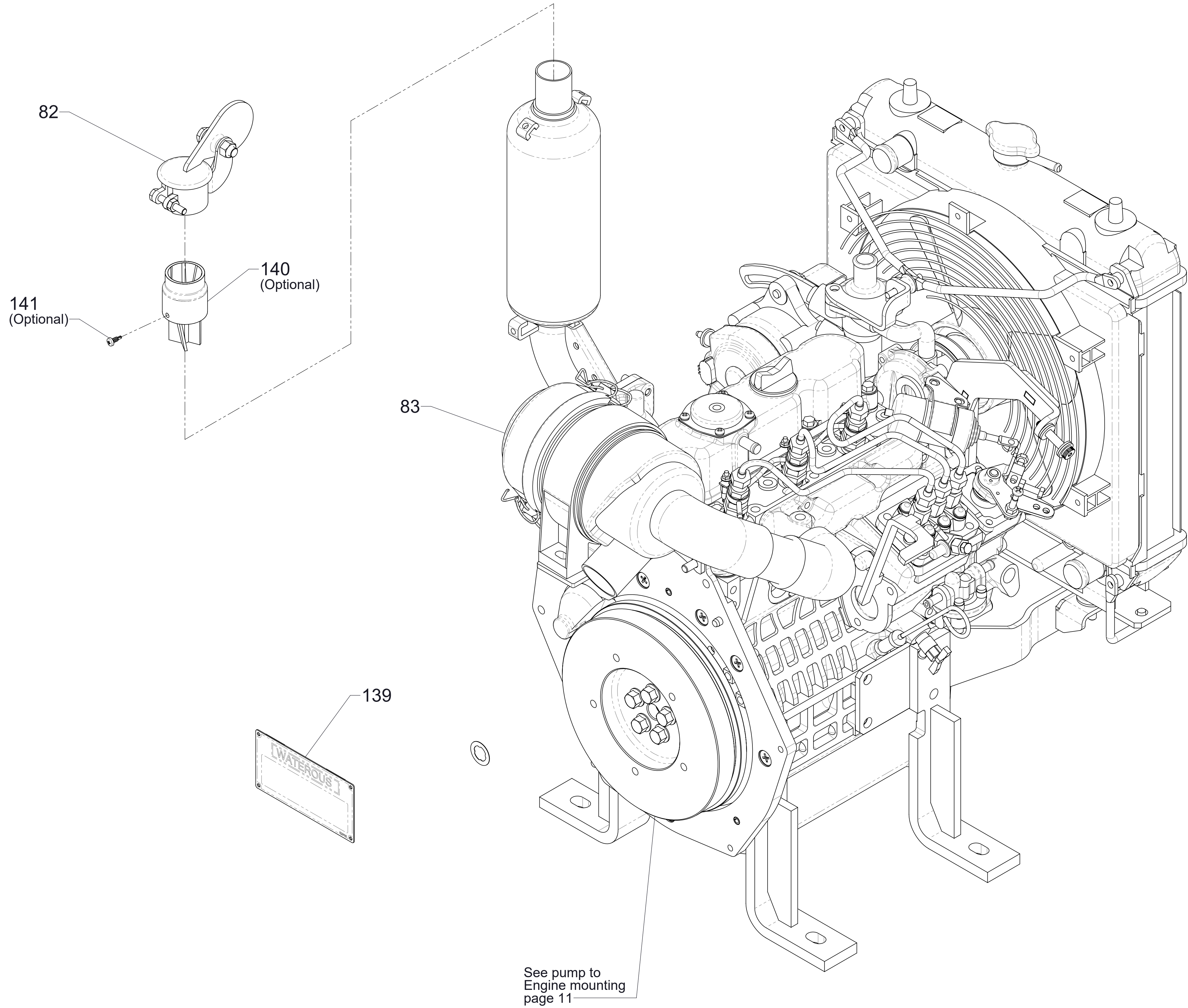

Diesel Engine
 (Models E501-C and E511-C)

Instrument Panel for Single or Dual Options

Ref. No.	Description
11	Switch Knob
12	Ignition Switch
17	Panel Plate
101	Single Panel Subassembly
105	Dual Panel Subassembly
110	Intake Gauge
111	Discharge Gauge
132	Single Panel Wire Harness

Ref. No.	Description
134	Dual Panel Wire Harness
145	Engine Control Module (Includes ref no. 146 and 147)
146	Pan Hd Screw, #10-24 x 1/2 in.
147	Lockwasher, #10
148	Push Button Switch
149	Contact Block, N.C.
150	Contact Block, N.O.

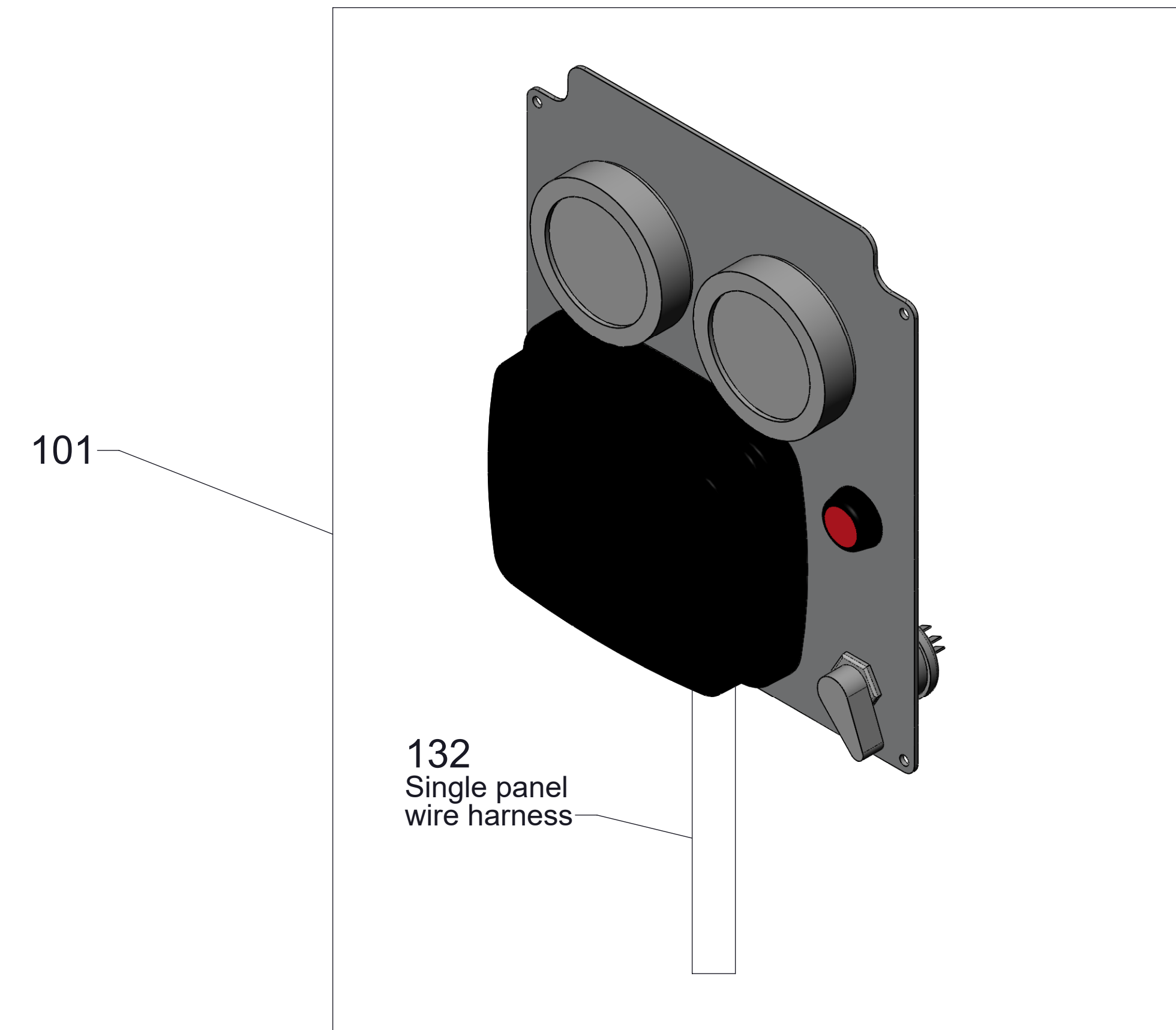
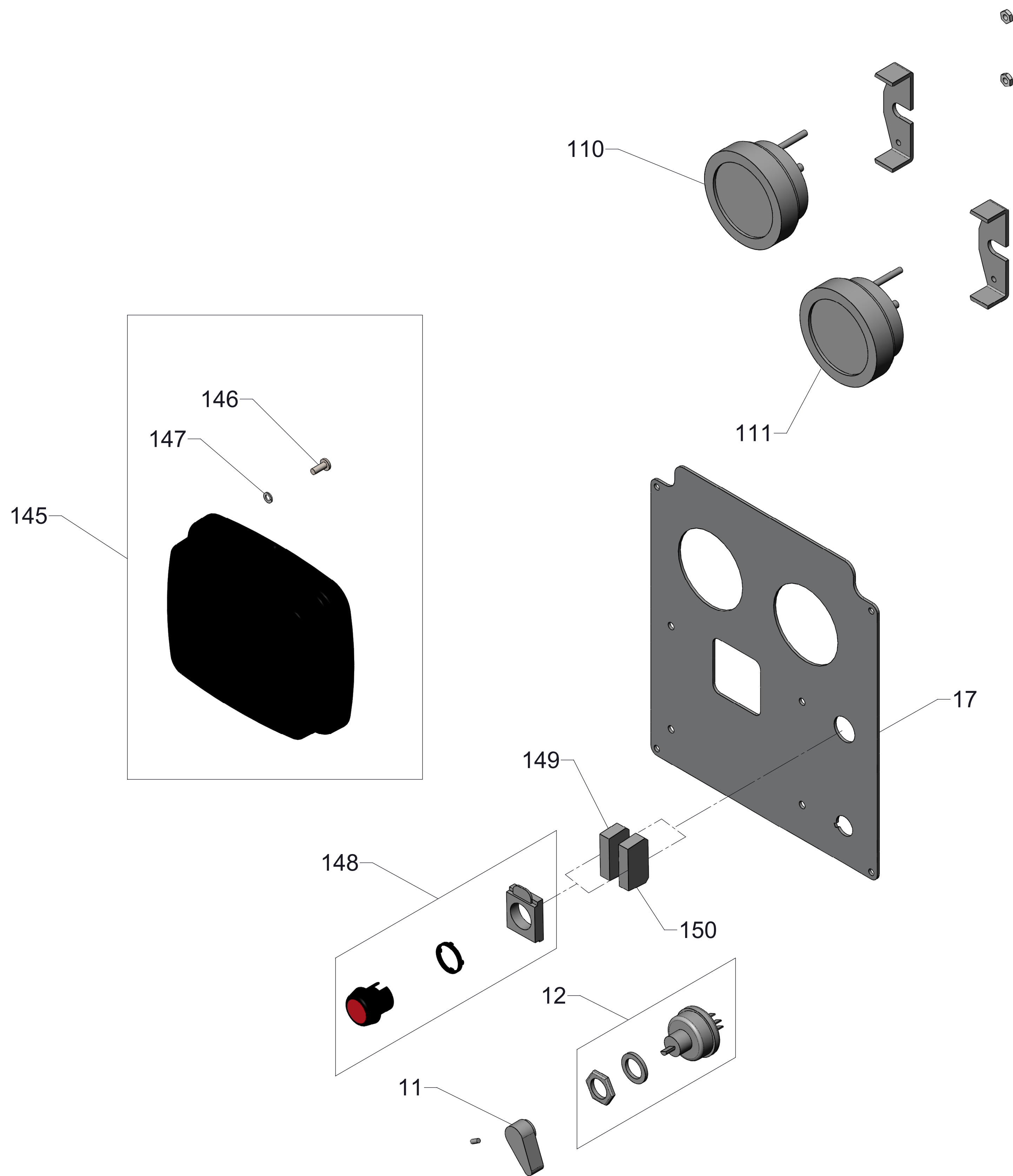

Single Panel Sub-Assembly

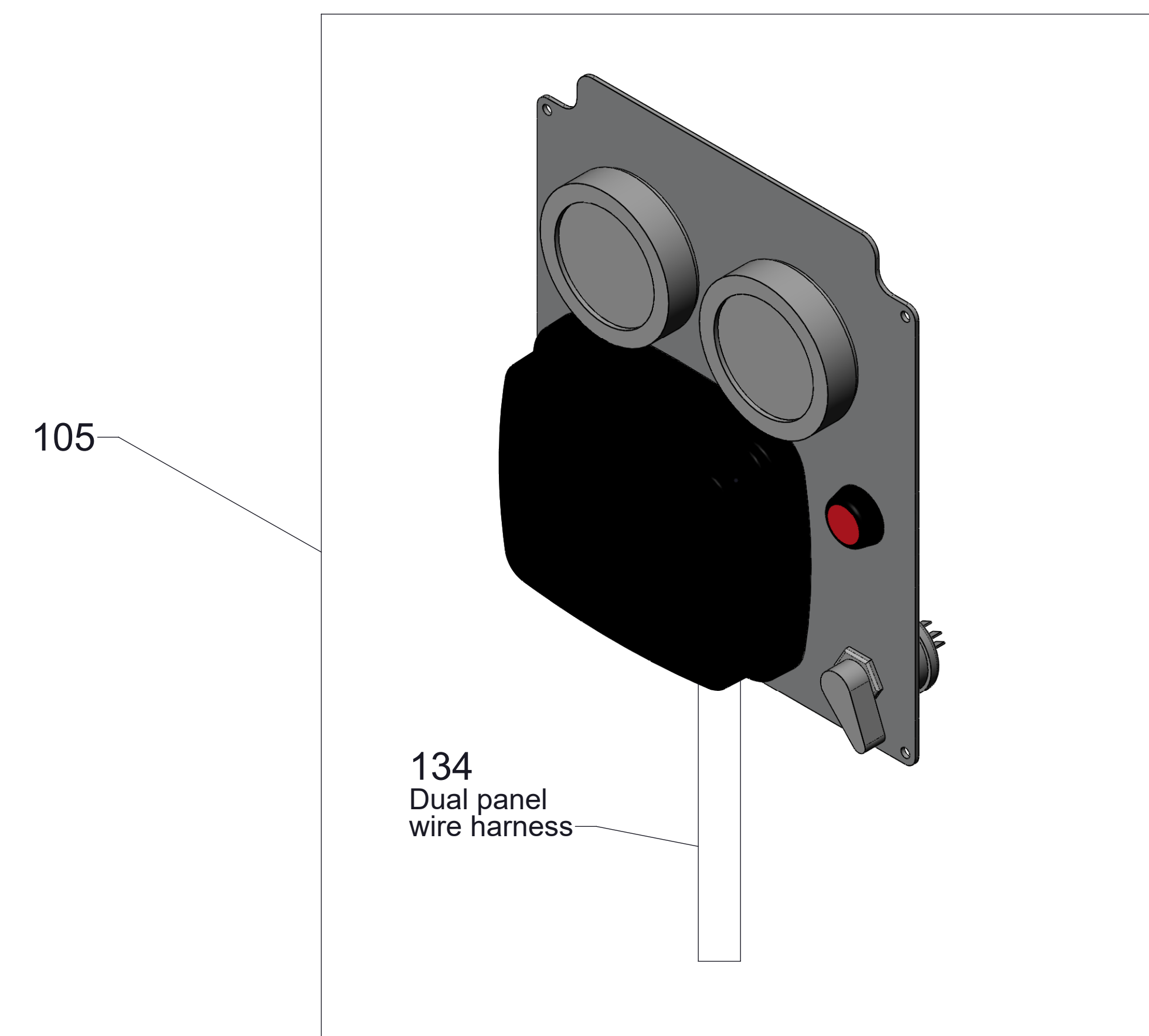

Dual Panel Sub-Assembly