

CAFS Assembly Service Parts List

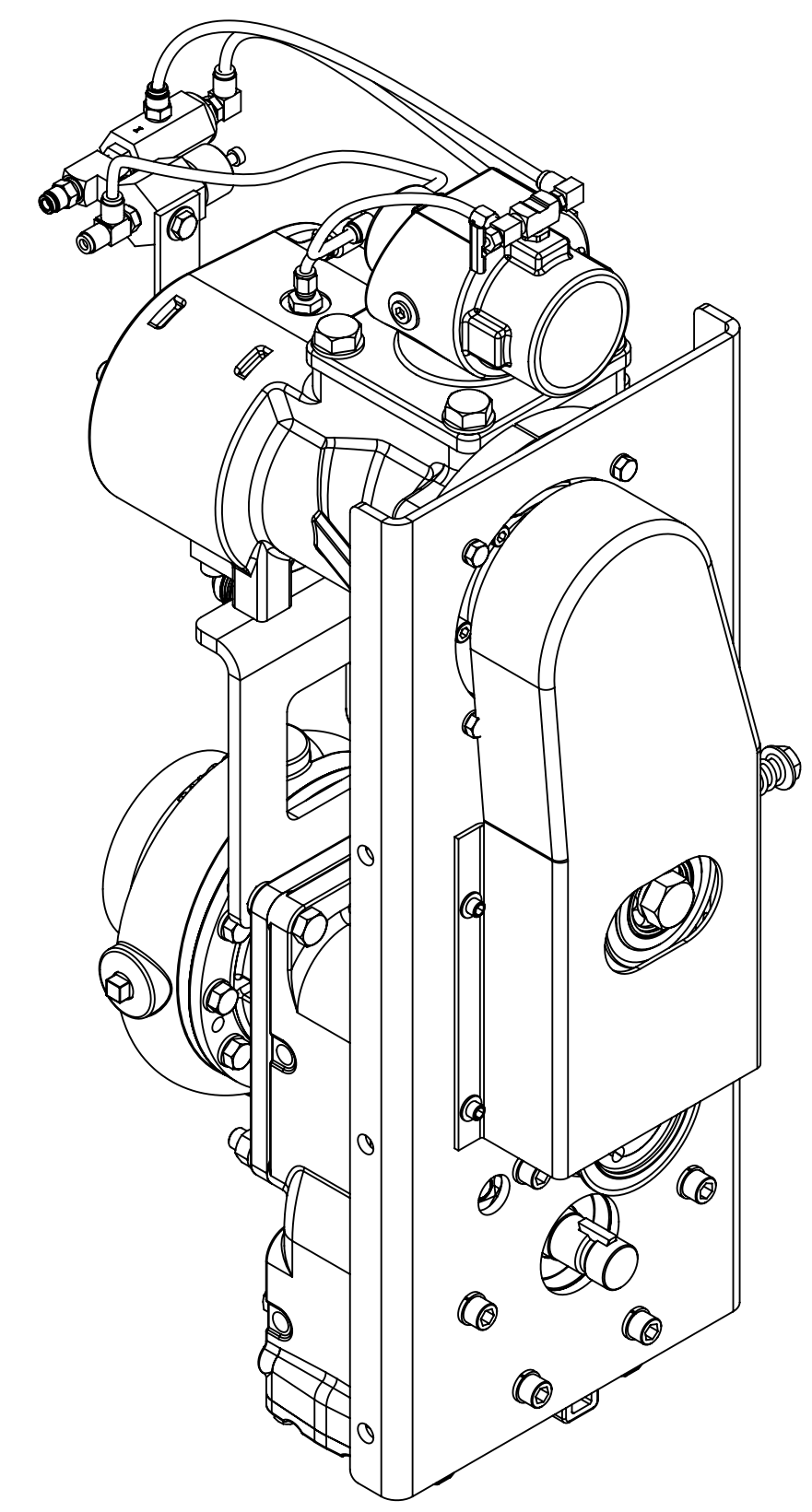

CAFS Type	Covers the following models:		
	Stand-Alone CAFS Model <small>(After 04/01/22)</small>	PTO CAFS Model <small>(Prior to 04/01/2022)</small>	See Index on Page
Traditional	100-P 120-P	250-100-P 250-120-P	3
	100-P 120-P	500-100-P 500-120-P	
	150-P	500-150-P	
	100-P	750-100-P 1000-100-P 1250-100-P	
	150-P	750-150-P 1000-150-P 1250-150-P	
	150-T	750-150-T 1000-150-T 1250-150-T	
Eclipse GEN 2.0	150-ECL	750-150-ECL 1000-150-ECL 1250-150-ECL	
	150-ECLT	750-150-ECLT 1000-150-ECLT 1250-150-ECLT	

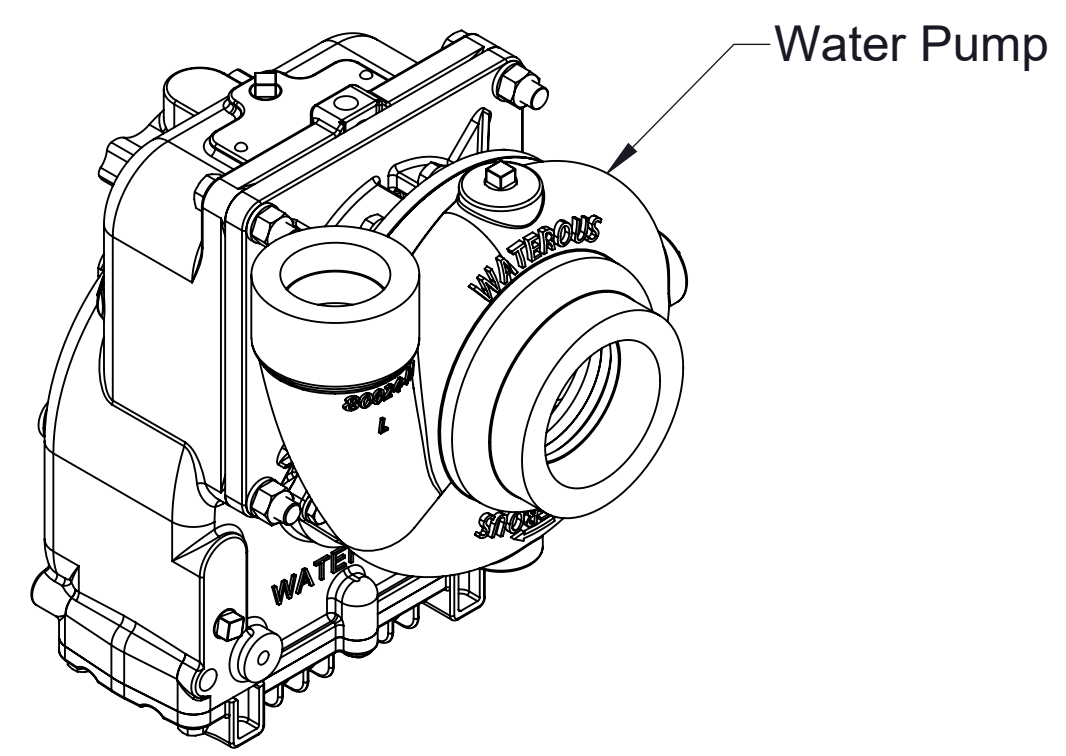
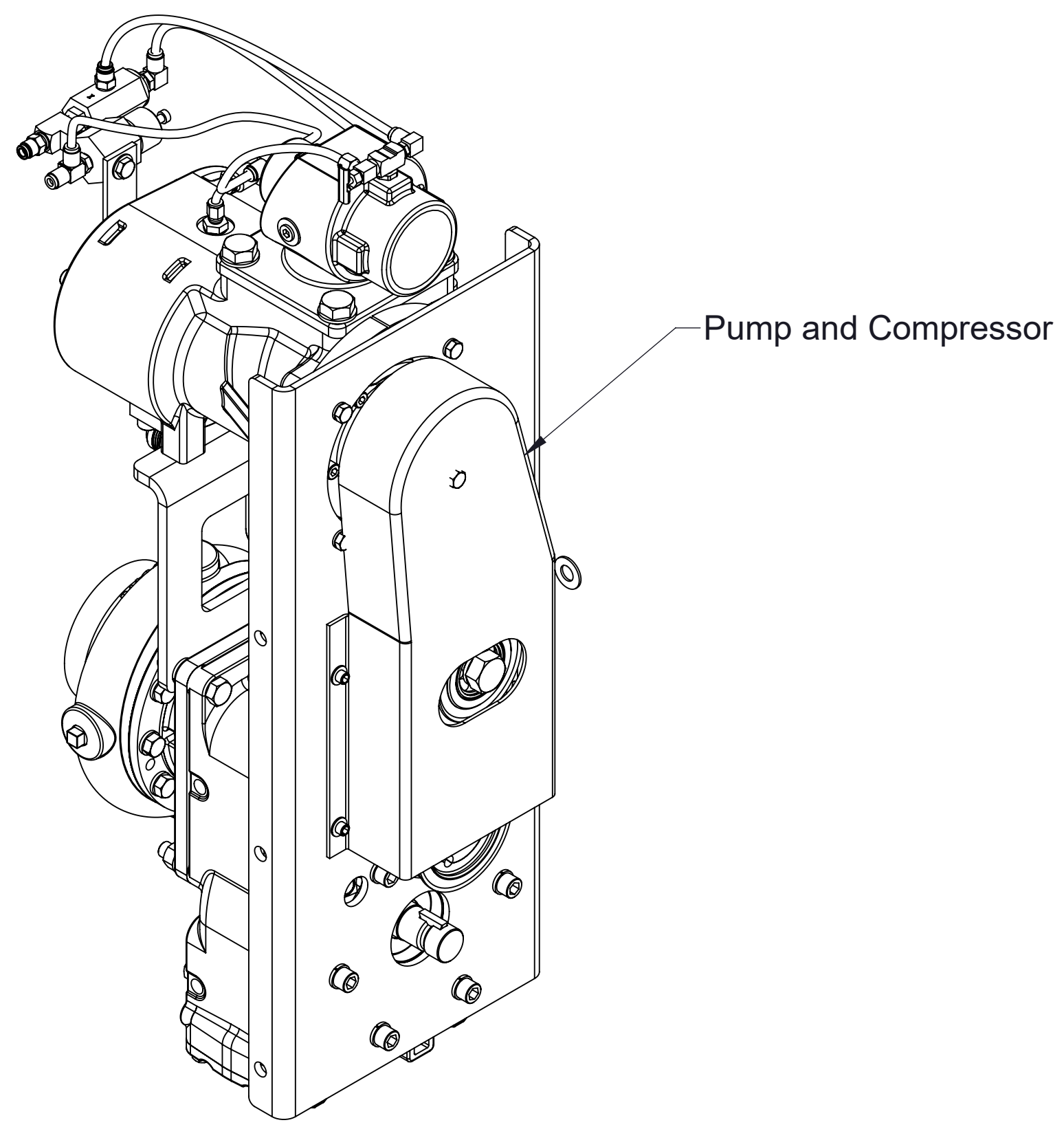

**Air Pressure Gauge
(Optional)**

**Hoses and Fittings Kit
(Optional)**

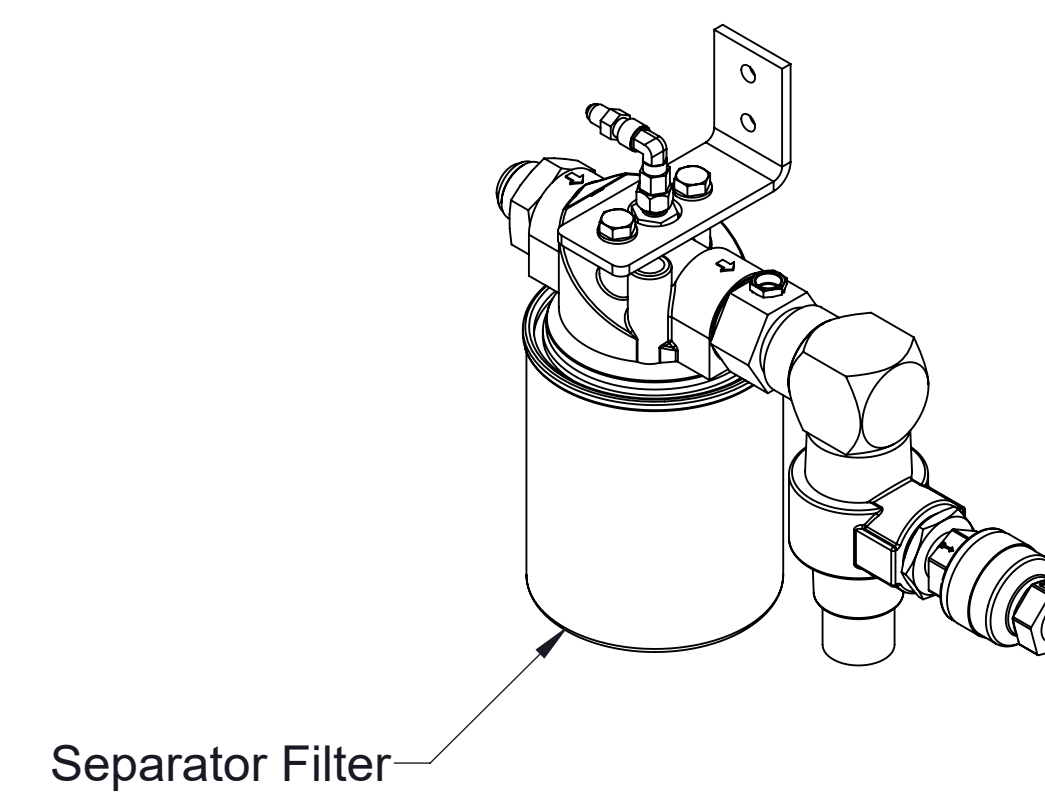
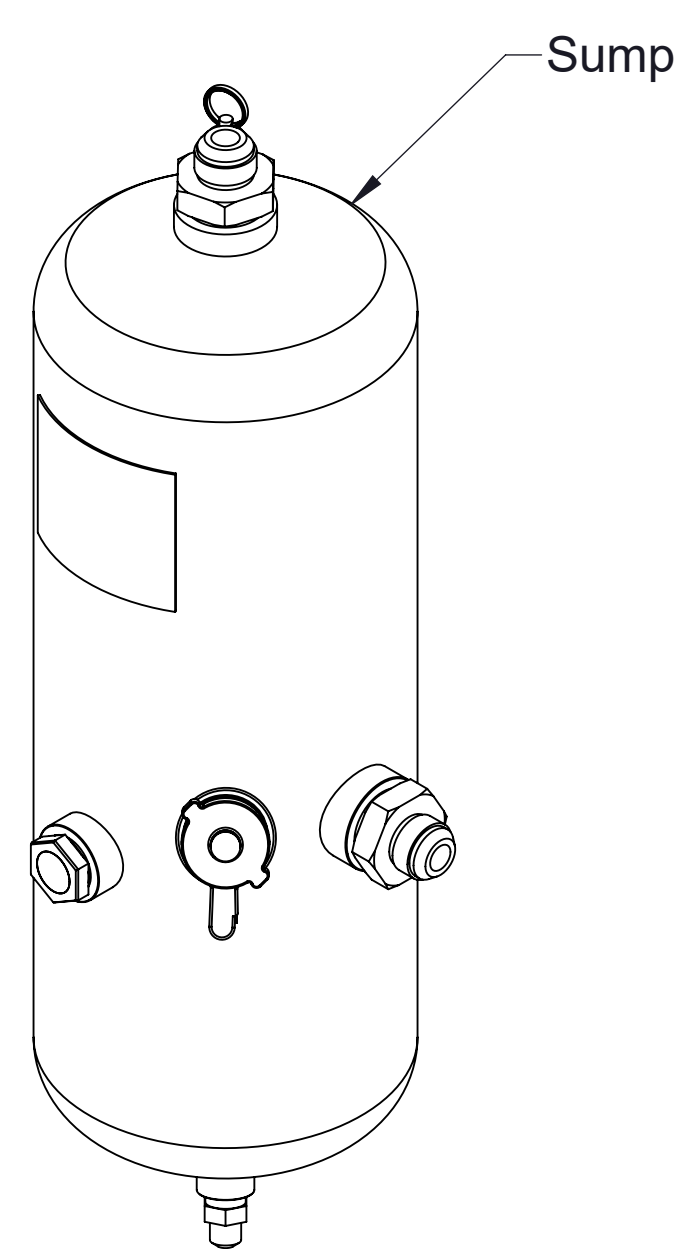
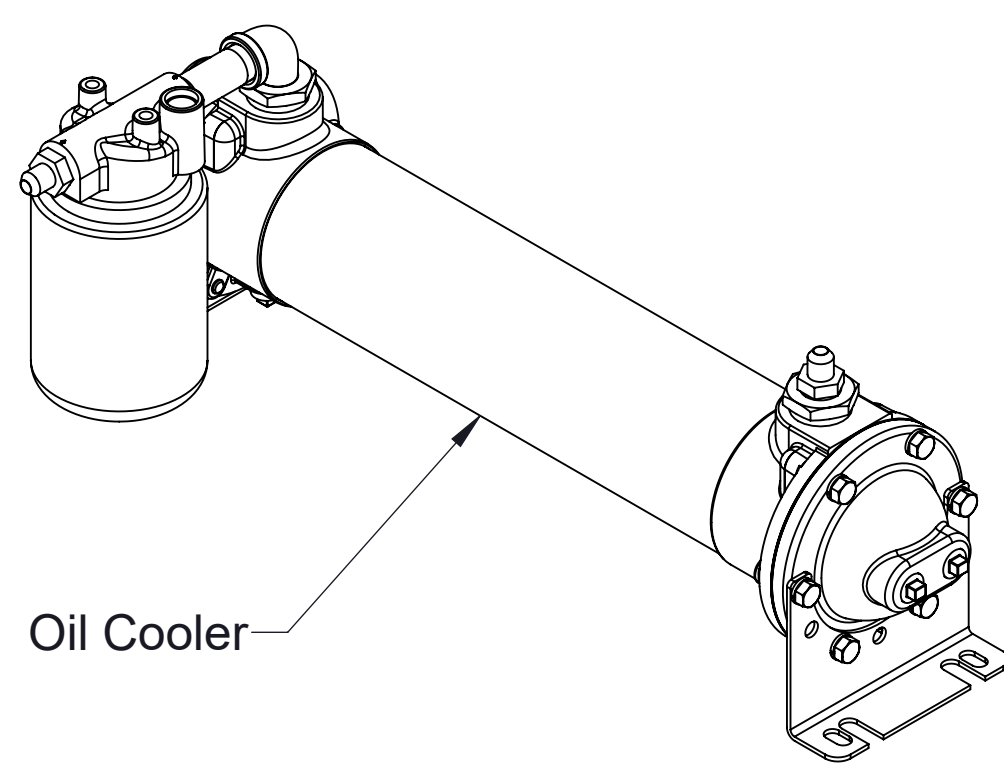
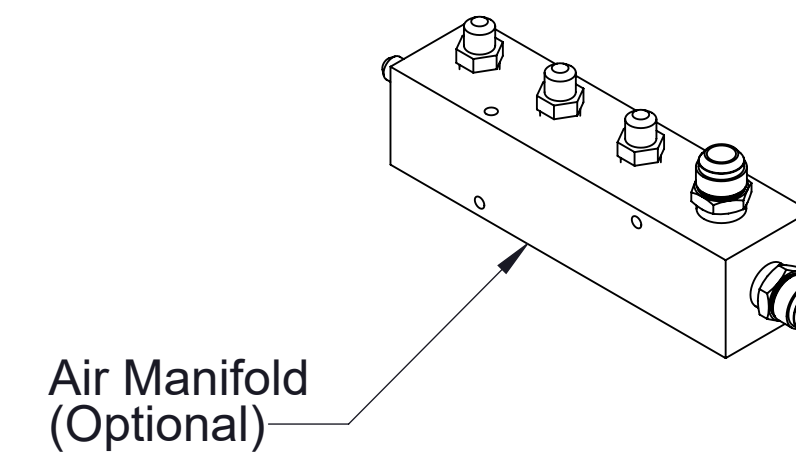
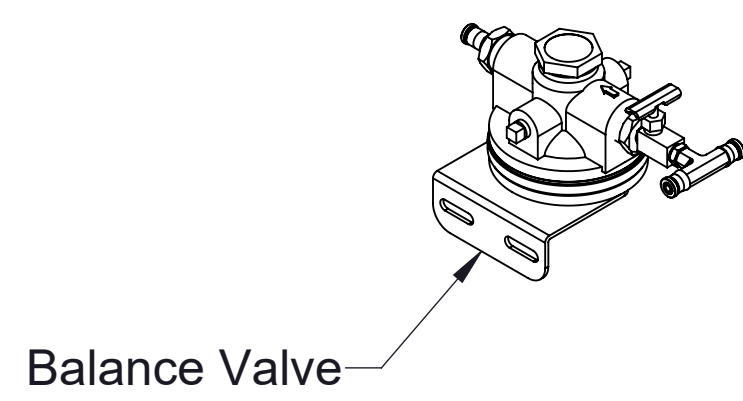
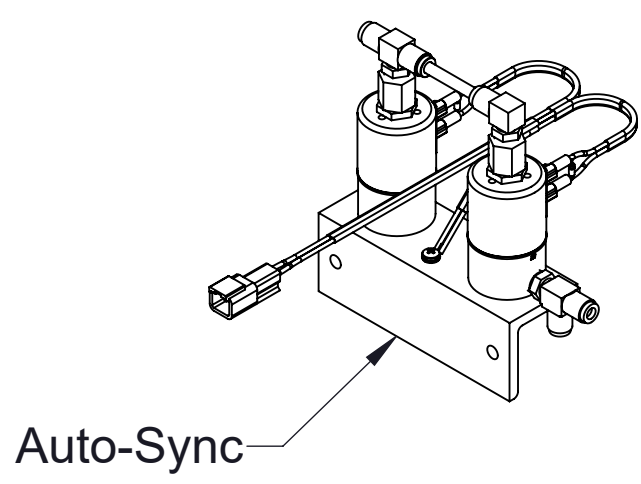

Component	Model				See Pages		
	Traditional CAFS	Eclipse GEN 2.0	Included Water Pump Model	Transmission Mounting	Pump and Compressor	Compressor Subassembly	Air Filter
Pump and Compressor	100-P 120-P	--	CPK-2	Vertical	4	11, 13	14
				Left	5		
	100-P 120-P	--	CLVK	Vertical	6		
				150-P	--	CLVK	
	150-P	150-ECL	CXNK CXSK CXVK CXNPA CXSPA CXVPA	Left	8	12, 13	
				Vertical	9		
150-T	150-ECLT	CXNT CXST CXVT	Left	10			
Panel Components	All Models				15		
Air Schematic	Traditional CAFS, models ending with -P				16		
	Generated CAFS, models ending with -ECL	Non High-Rise			17		
		High-Rise			18		
Electrical Schematic	Traditional CAFS, models ending with -P				19		
	Generated CAFS, models ending with -ECL				See Foam Generator Service Parts List		
Auto-Sync	See Auto-Sync Service Parts List Traditional CAFS, models ending with -P or -T Generated CAFS with High-Rise option only, models ending with -ECL or -ECLT						
Balance Valve	See Balance Valve Service Parts List (all models)						
Oil Cooler	See Oil Cooler Service Parts List (all models)						
Separator Filter	See Separator Filter Service Parts List (all models)						
Sump	See Sump Service Parts List (all models)						
Water Pump	See Pump and Transmission Service Parts List (all models)						
Hydraulic Schematic	See Hoses and Fitting Kit Service Parts List						
Air Manifold CAFS Discharge Air Pressure Gauge Hoses and Fittings	Optional from Waterous, may have been furnished by OEM. See the following Service Parts Lists: Air Manifold Air Discharge Kits Air Pressure Gauge Hoses and Fittings ICS Valves						

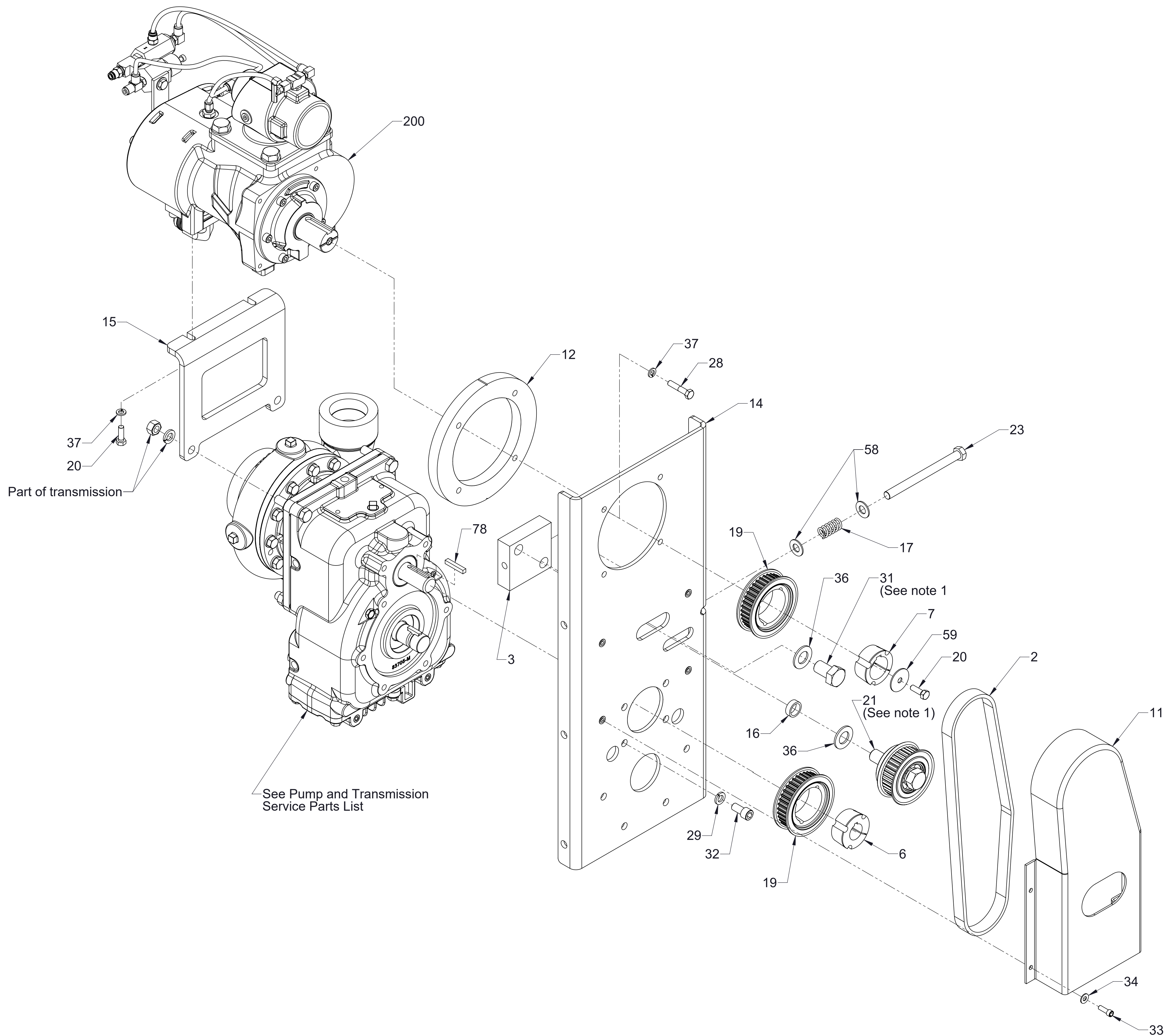

Ref No.	Description
2	Belt-Poly Chain, 8MGT-1000-21
3	Block-Belt Tensioner
6	Bushing-Taperlock, 1-1/6 x 1610
7	Bushing-Taperlock, 38 mm x 1610
11	Guard-Belt, Vertical Gear Case
12	Plate-Spacer
14	Plate-Front Compressor Mount, 250-100-P
15	Bracket-Rear Compressor Support, 250-100-P
16	Spacer-Idler Belt Tensioner
17	Spring-Tensioner, Belt
19	Sprocket-8MX-36S-21TL
20	Screw-Hex Hd, M8-1.25 x 25 mm
21	Idler Sprocket 21 MM Poly Chain
23	Screw-Hex Hd, 1/2-13 x 6 in
28	Screw-Hex Hd, M8-1.25 x 40 mm
29	Washer-Lock, 7/16 in
31	Screw-Hex Hd, 3/4-16 x 1-1/4 in
32	Screw-Cap, Hex Soc Hd, 7/16-14 x 7/8 in
33	Screw-Cap, Hex Soc Hd, 1/4-20 x 3/4 in
34	Washer-Plain, 1/4 in
36	Washer-Plain, 3/4 in
37	Washer-Lock, 8 mm
58	Washer-Plain, 1/2 in
59	Washer, .344 x 1.50 x .062 in
78	Key-Square, 1/4 x 1-1/2 in
200	Compressor Subassembly

Note:
 1. Clean threads and prime. Apply Loctite #242/243 (blue) to threads.
 Torque to 200-220 ft lb.

Pump and Compressor
 Models 250-100-P, 250-120-P

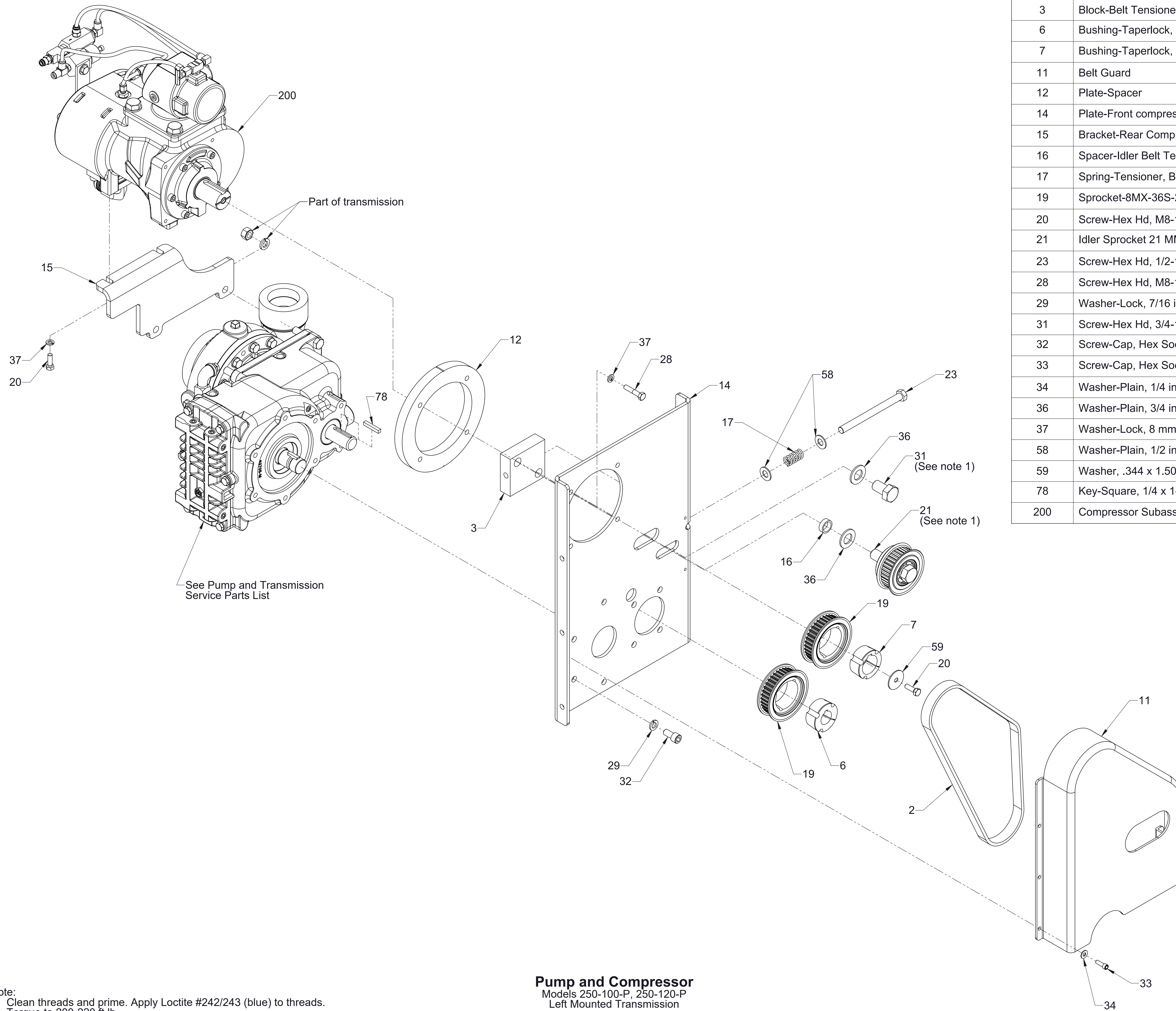

Ref No.	Description
2	Belt-Poly Chain
3	Block-Belt Tensioner
6	Bushing-Taperlock, 1-1/6 x 1610
7	Bushing-Taperlock, 38 mm x 1610
11	Belt Guard
12	Plate-Spacer
14	Plate-Front compressor mount,
15	Bracket-Rear Compressor support
16	Spacer-Idler Belt Tensioner
17	Spring-Tensioner, Belt
19	Sprocket-8MX-36S-21TL
20	Screw-Hex Hd, M8-1.25 x 25 mm
21	Idler Sprocket 21 MM Poly Chain
23	Screw-Hex Hd, 1/2-13 x 6 in
28	Screw-Hex Hd, M8-1.25 x 40 mm
29	Washer-Lock, 7/16 in
31	Screw-Hex Hd, 3/4-16 x 1-1/4 in
32	Screw-Cap, Hex Soc Hd, 7/16-14 x 7/8 in
33	Screw-Cap, Hex Soc Hd, 1/4-20 x 3/4 in
34	Washer-Plain, 1/4 in
36	Washer-Plain, 3/4 in
37	Washer-Lock, 8 mm
58	Washer-Plain, 1/2 in
59	Washer, .344 x 1.50 x .062 in
78	Key-Square, 1/4 x 1-1/2 in
200	Compressor Subassembly

Note:
 1. Clean threads and prime. Apply Loctite #242/243 (blue) to threads.
 Torque to 200-220 ft lb.

Pump and Compressor
 Models 250-100-P, 250-120-P
 Left Mounted Transmission

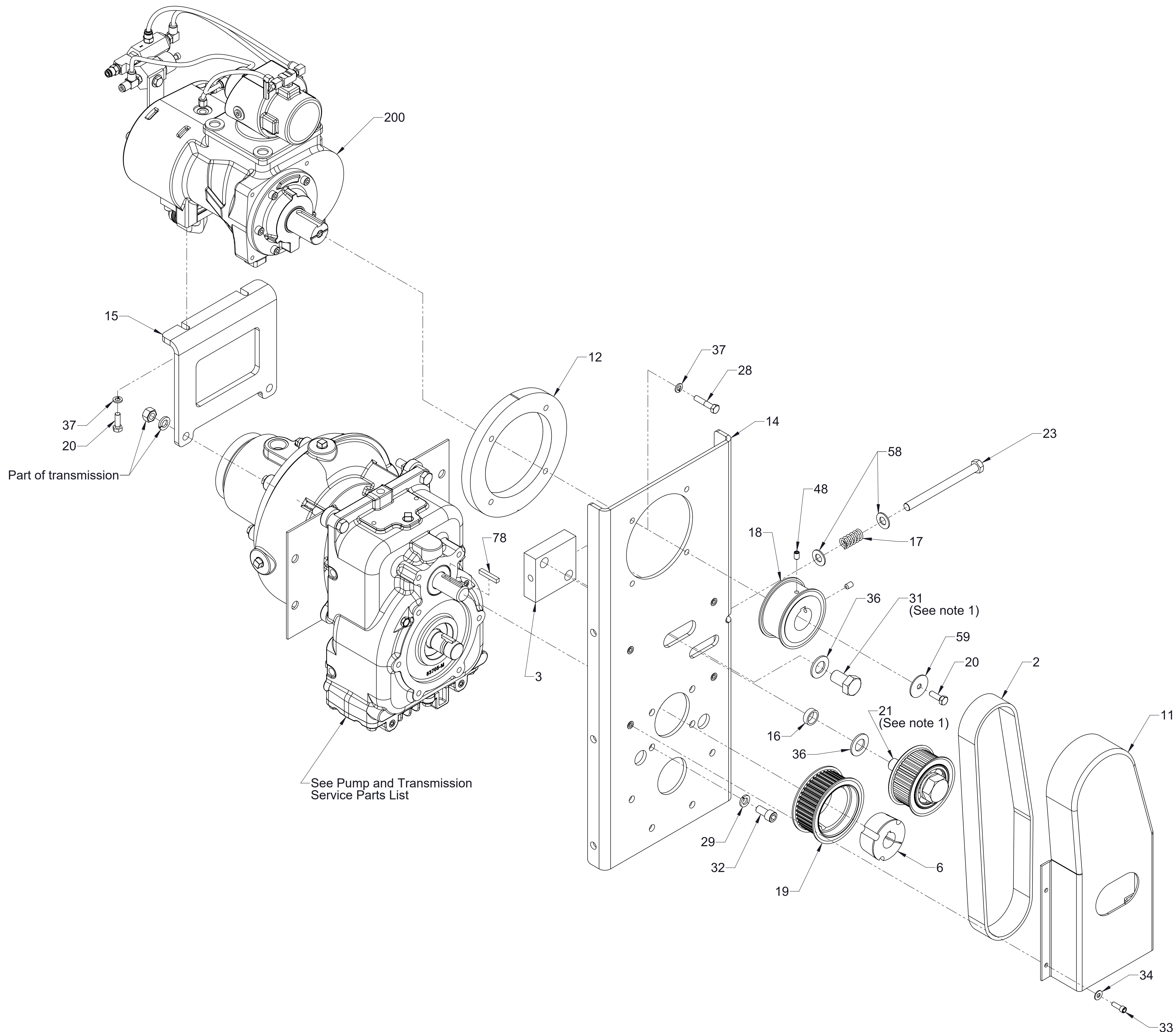

Ref No.	Description
2	Belt-Poly Chain
3	Block-Belt Tensioner
6	Taperlock Bushing, 1-1/16 x 2012
11	Guard-Belt, Vertical Gear Case
12	Plate-Spacer
14	Plate-Front Compressor Mount, 250-100-P
15	Bracket-Rear Compressor Support, 250-100-P
16	Spacer-Idler Belt Tensioner
17	Spring-Tensioner, Belt
18	Sprocket, 500-100-P
19	Sprocket-8MX-40S-36TL
20	Screw-Hex Hd, M8-1.25 x 25 mm
21	Idler-Sprocket, 36 mm
23	Screw-Hex Hd, 1/2-13 x 6 in
28	Screw-Hex Hd, M8-1.25 x 40 mm
29	Washer-Lock, 7/16 in
31	Screw-Hex Hd, 3/4-16 x 1-1/4 in
32	Screw-Cap, Hex Soc Hd, 7/16-14 x 7/8 in
33	Screw-Cap, Hex Soc Hd, 1/4-20 x 3/4 in
34	Washer-Plain, 1/4 in
36	Washer-Plain, 3/4 in
37	Washer-Lock, 8 mm
48	Screw-Set, Cup Point, Hex Soc, 5/16-18 x 1/2 in
58	Washer-Plain, 1/2 in
59	Washer, .344 x 1.50 x .062 in
78	Key-Square, 1/4 x 1-1/2 in
200	Compressor Subassembly

Note:
 1. Clean threads and prime. Apply Loctite #242/243 (blue) to threads.
 Torque to 200-220 ft lb.

Pump and Compressor
 Models 500-100-P, 500-120-P

24
Prior to June 1, 2022
130
After June 1, 2022

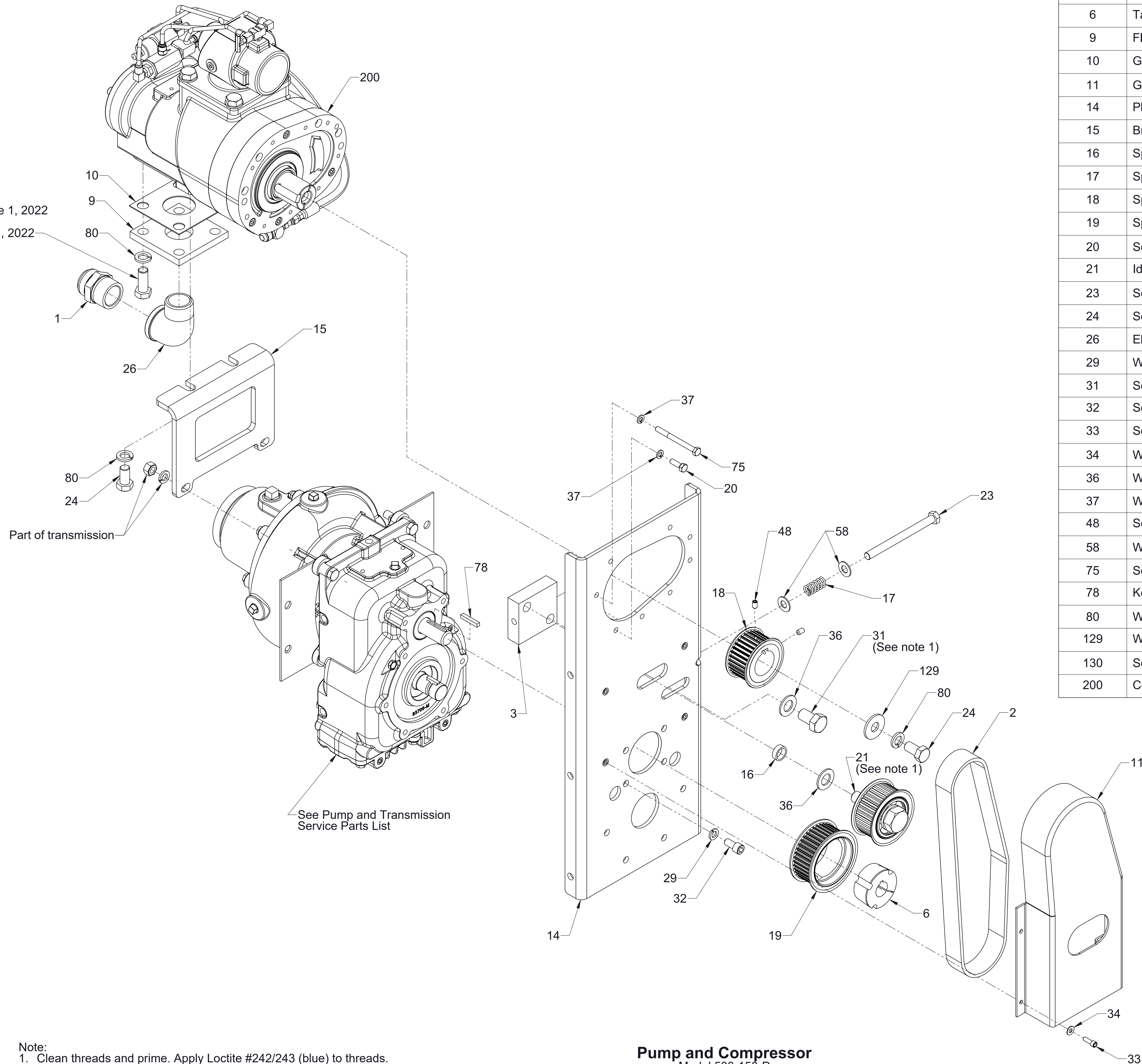

Ref No.	Description
1	Adapter-Straight, 24 MJIC x 1-1/2 MNPT
2	Belt-Poly Chain
3	Block-Belt Tensioner
6	Taperlock Bushing, 1-1/16 x 2012
9	Flange-Outlet
10	Gasket-Outlet Flange
11	Guard-Belt, Vertical Gear Case
14	Plate-Front Compressor Mount, 500-150-P
15	Bracket-Rear Compressor Support, 500-150-P
16	Spacer-Idler Belt Tensioner P-KITS
17	Spring-Tensioner, Belt
18	Sprocket (make from PB8MX-32S-36)
19	Sprocket-8MX-40S-36TL
20	Screw-Hex Hd, M8-1.25 x 25 mm
21	Idler-Sprocket, 36 mm
23	Screw-Hex Hd, 1/2-13 x 6 in
24	Screw-Hex Hd, M16-2 x 30 mm
26	Elbow-Street, 90°, 1-1/2 NPT
29	Washer-Lock, 7/16 in
31	Screw-Hex Hd, 3/4-16 x 1-1/4 in
32	Screw-Cap, Hex Soc Hd, 7/16-14 x 7/8 in
33	Screw-Cap, Hex Soc Hd, 1/4-20 x 3/4 in
34	Washer-Plain, 1/4 in
36	Washer-Plain, 3/4 in
37	Washer-Lock, 8 mm
48	Screw-Set, Cup Point, Hex Soc, 5/16-18 x 1/2 in
58	Washer-Plain, 1/2 in
75	Screw-Hex Hd, M8-1.25 x 90 mm
78	Key-Square, 1/4 x 1-1/2 in
80	Washer-Lock, 16 mm
129	Washer-Large Diameter
130	Screw-Hex Hd, M16-2 x 40 mm
200	Compressor Subassembly

Note:
1. Clean threads and prime. Apply Loctite #242/243 (blue) to threads.
Torque to 200-220 ft lb.

Pump and Compressor
Model 500-150-P

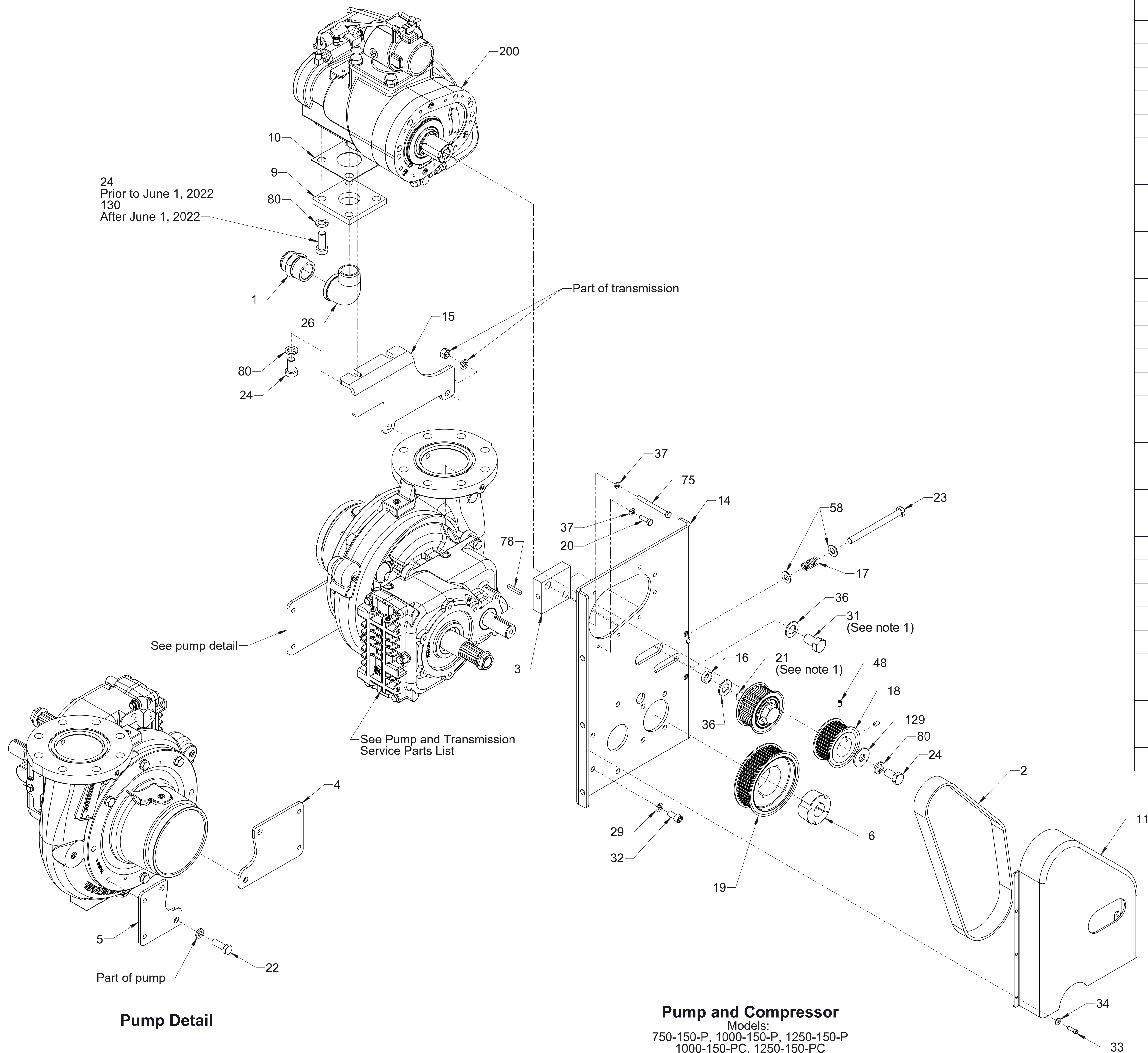

Ref No.	Description
1	Adapter-Straight, 24 MJIC x 1-1/2 MNPT
2	Belt-Poly Chain
3	Block-Belt Tensioner
4	Bracket-Pump Support, Long
5	Bracket-Pump Support, Short
6	Bushing-Taperlock, 1-1/4 x 2012
9	Flange-Outlet
10	Gasket-Outlet Flange
11	Belt Guard 750 / 1000 / 1250-P
14	Plate-Front Compressor Mount, 750/1000/1250-150-P
15	Bracket-Rear Compressor Support, 750/1000/1250-150-P
16	Spacer-Idler Belt Tensioner
17	Spring-Tensioner, Belt
18	Sprocket
19	Sprocket 8MX-56S-36-TL (2012)
20	Screw-Hex Hd, M8-1.25 x 25 mm
21	Idler-Sprocket, 36 mm
22	Screw-Hex Hd, 1/2-13 x 1-1/2 in
23	Screw-Hex Hd, 1/2-13 x 6 in
24	Screw-Hex Hd, M16-2 x 30 mm
26	Elbow-Street, 90°, 1-1/2 NPT
29	Washer-Lock, 7/16 in
31	Screw-Hex Hd, 3/4-16 x 1-1/4 in
32	Screw-Cap, Hex Soc Hd, 7/16-14 x 7/8 in
33	Screw-Cap, Hex Soc Hd, 1/4-20 x 3/4 in
34	Washer-Plain, 1/4 in
36	Washer-Plain, 3/4 in
37	Washer-Lock, 8 mm
48	Screw-Set, Cup Point, Hex Soc, 5/16-18 x 1/2 in
58	Washer-Plain, 1/2 in
75	Screw-Hex Hd, M8-1.25 x 90 mm
78	Key-Square, 1/4 x 1-1/2 in
80	Washer-Lock, 16 mm
129	Washer-Large Diameter
130	Screw-Hex Hd, M16-2 x 40 mm
200	Compressor Subassembly

Note:
 1. Clean threads and prime. Apply Loctite #242/243 (blue) to threads.
 Torque to 200-220 ft lb.

Pump and Compressor
 Models:
 750-150-P, 1000-150-P, 1250-150-P
 1000-150-PC, 1250-150-PC
 750-150-ECL, 1000-150-ECL, 1250-150-ECL
 (Pump Models: CXNK, CXSK, CXVK)

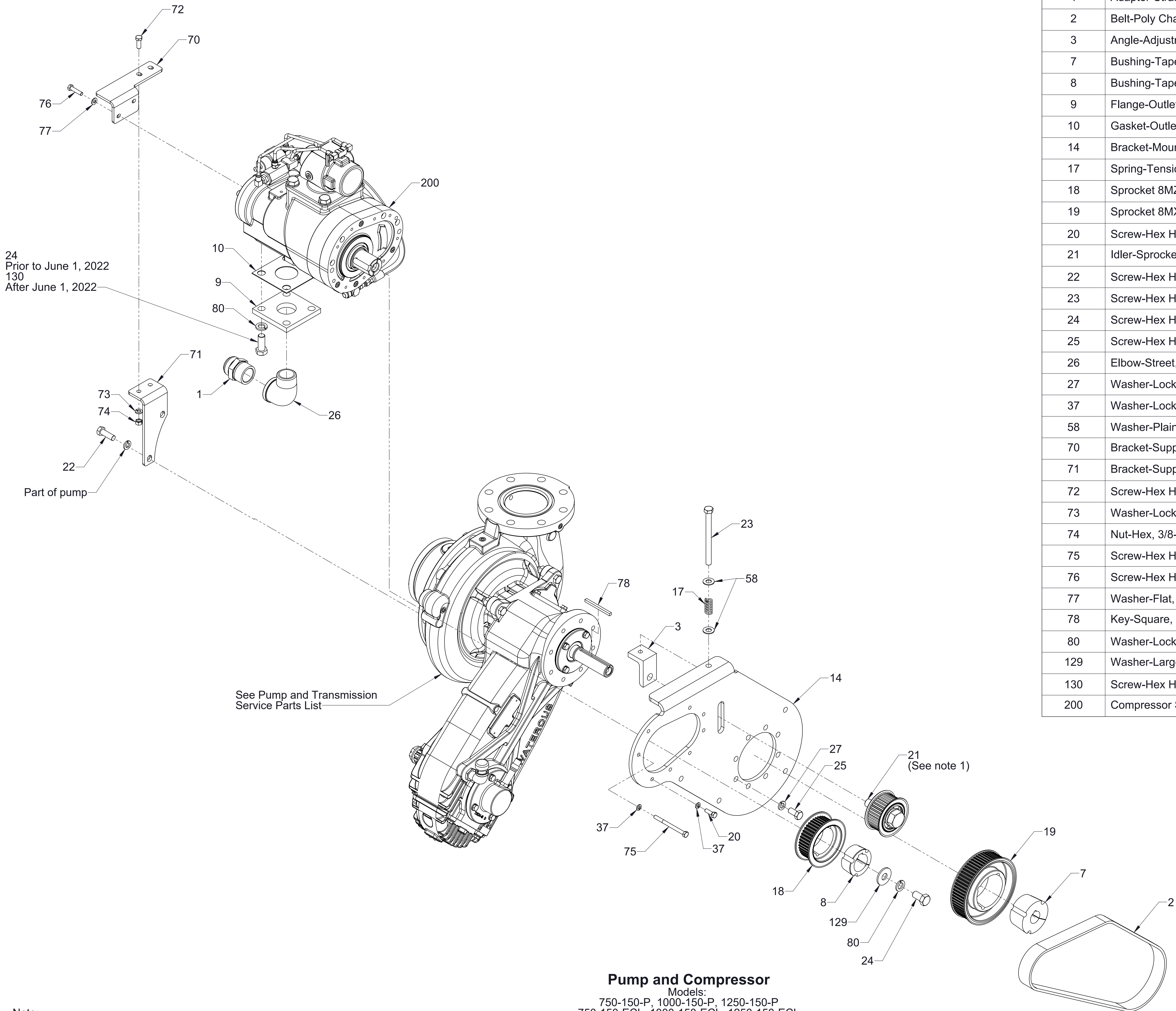

Ref No.	Description
1	Adapter-Straight, 24 MJIC x 1-1/2 MNPT
2	Belt-Poly Chain
3	Angle-Adjustment, Idler
7	Bushing-Taper Lock, 1-1/4 x 2517
8	Bushing-Taper Lock, 45 mm x 2012
9	Flange-Outlet
10	Gasket-Outlet Flange
14	Bracket-Mount, Compressor
17	Spring-Tensioner, Belt
18	Sprocket 8MZ-42S-36-TL2012
19	Sprocket 8MX-67S-36-TL (2517)
20	Screw-Hex Hd, M8-1.25 x 25 mm
21	Idler-Sprocket, 36 mm
22	Screw-Hex Hd, 1/2-13 x 1-1/2 in
23	Screw-Hex Hd, 1/2-13 x 6 in
24	Screw-Hex Hd, M16-2 x 30 mm
25	Screw-Hex Hd, 1/2-13 x 1 in
26	Elbow-Street, 90°, 1-1/2 NPT
27	Washer-Lock, 1/2 in
37	Washer-Lock, 8 mm
58	Washer-Plain, 1/2 in
70	Bracket-Support, Compressor, Upper
71	Bracket-Support, Compressor, Lower
72	Screw-Hex Hd, 3/8-16 x 1 in
73	Washer-Lock, 3/8 in
74	Nut-Hex, 3/8-16
75	Screw-Hex Hd, M8-1.25 x 100 mm
76	Screw-Hex Hd, M8-1.25 x 35 mm
77	Washer-Flat, 8 mm
78	Key-Square, 1/4 x 3-1/8 in
80	Washer-Lock, 16 mm
129	Washer-Large Diameter
130	Screw-Hex Hd, M16-2 x 40 mm
200	Compressor Subassembly

Pump and Compressor
 Models:
 750-150-P, 1000-150-P, 1250-150-P
 750-150-ECL, 1000-150-ECL, 1250-150-ECL
 (Pump Models: CXNPA, CXSPA, CXVPA)

Note:
 1. Clean threads and prime. Apply Loctite #242/243 (blue) to threads.
 Torque to 200-220 ft lb.

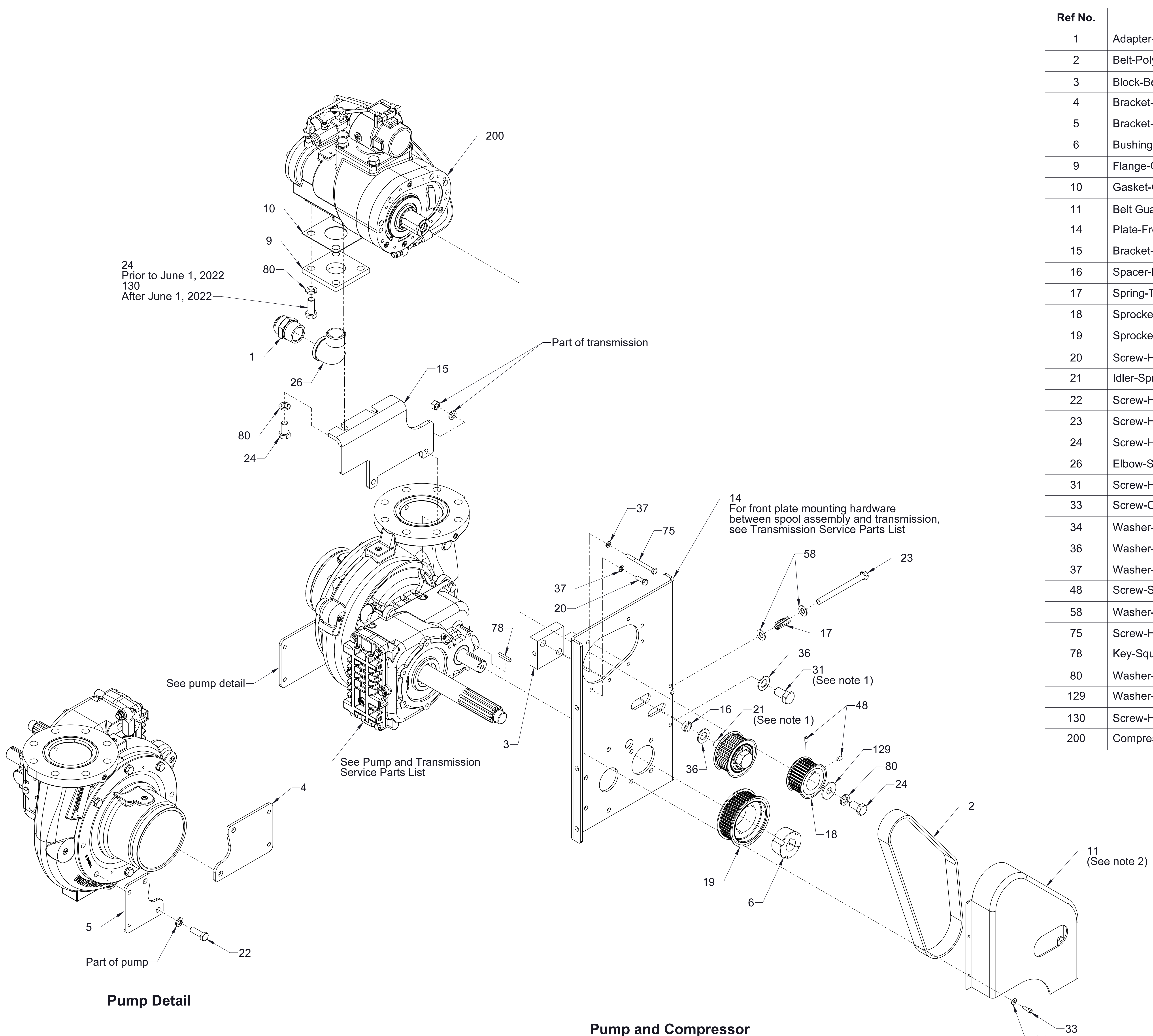

Ref No.	Description
1	Adapter-Straight, 24 MJIC x 1-1/2 MNPT
2	Belt-Poly Chain
3	Block-Belt Tensioner
4	Bracket-Pump Support, Long
5	Bracket-Pump Support, Short
6	Bushing-Taperlock, 1-1/4 x 2012
9	Flange-Outlet
10	Gasket-Outlet Flange
11	Belt Guard
14	Plate-Front Compressor Mount
15	Bracket-Rear Compressor Support, 150-T
16	Spacer-Idler Belt Tensioner
17	Spring-Tensioner, Belt
18	Sprocket (make from PB8MX-32S-36)
19	Sprocket 8MX-48S-36-TL
20	Screw-Hex Hd, M8-1.25 x 25 mm
21	Idler-Sprocket, 36 mm
22	Screw-Hex Hd, 1/2-13 x 1-1/2 in
23	Screw-Hex Hd, 1/2-13 x 6 in
24	Screw-Hex Hd, M16-2 x 30 mm
26	Elbow-Street, 90°, 1-1/2 NPT
31	Screw-Hex Hd, 3/4-16 x 1-1/4 in
33	Screw-Cap, Hex Soc Hd, 1/4-20 x 3/4 in
34	Washer-Plain, 1/4 in
36	Washer-Plain, 3/4 in
37	Washer-Lock, 8 mm
48	Screw-Set, Cup Point, Hex Soc, 5/16-18 x 1/2 in
58	Washer-Plain, 1/2 in
75	Screw-Hex Hd, M8-1.25 x 90 mm
78	Key-Square, 1/4 x 1-1/2 in
80	Washer-Lock, 16 mm
129	Washer-Large Diameter
130	Screw-Hex Hd, M16-2 x 40 mm
200	Compressor Subassembly

Notes:
 1. Clean threads and prime. Apply Loctite #242/243 (blue) to threads. Torque to 200-220 ft lb.
 2. Belt guard will need to be modified for clearance of spool gusset.

Pump and Compressor
 Models:
 750-150-T, 1000-150-T, 1250-150-T
 750-150-ECLT, 1000-150-ECLT, 1250-150-ECLT
 (Pump Models: CXNT, CXST, CXVT)

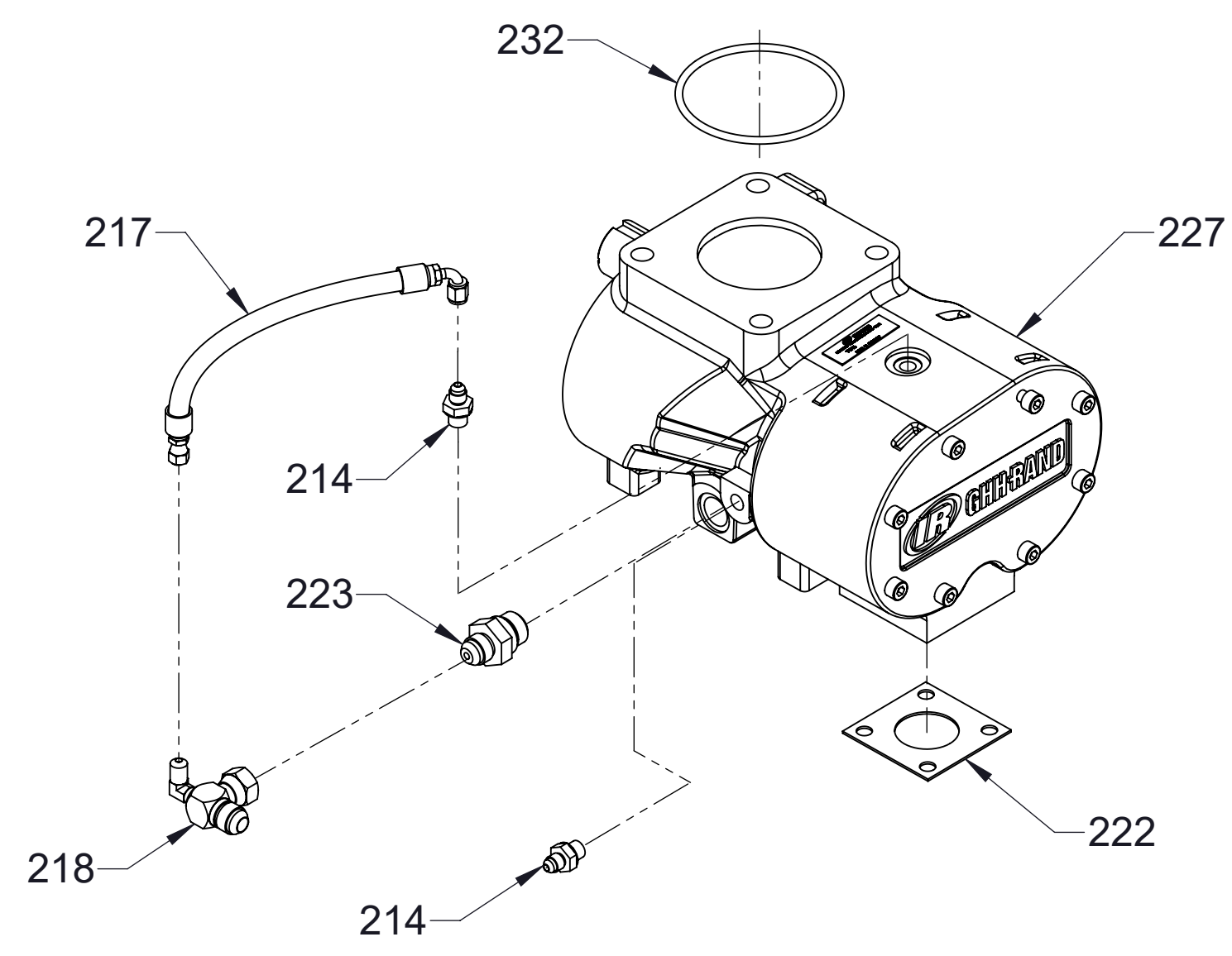

231
Compressor Replacement Kit

200
Compressor Subassembly
(includes 201-246 and 900)

247
Shaft Seal Repair Kit

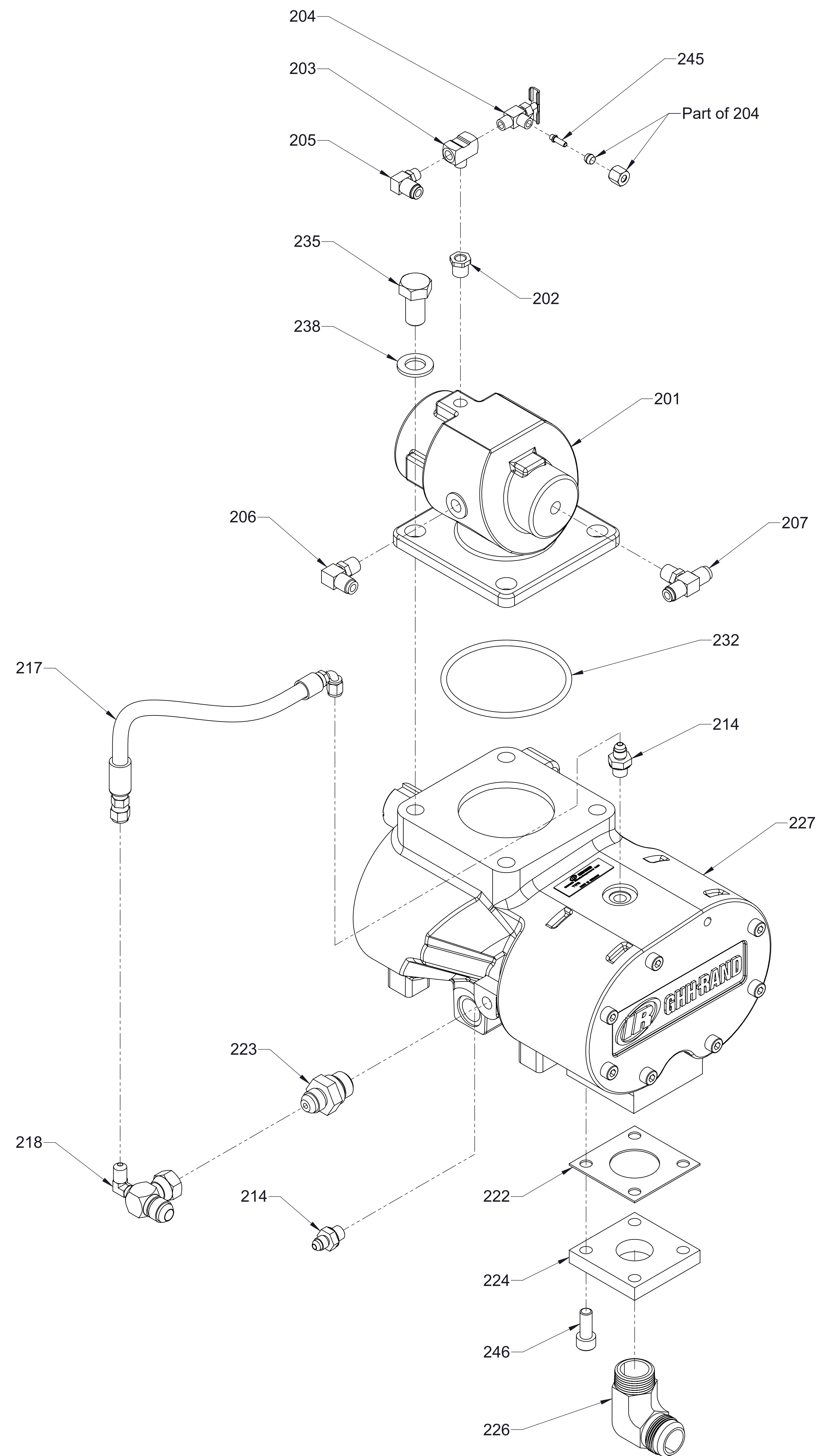

Compressor Subassembly
Models ending with 100-P, 120-P

Ref No.	Description
200	Compressor Subassembly (Includes 201-246 and 900)
201	Inlet-Air, 90°
202	Bushing-Reducing, 1/4 MNPT x 1/8 FNPT
203	Tee-Branch, 1/8 MNPT x 1/8 FNPT x 1/8 FNPT
204	Valve-Trim, 1/8 MNPT x 1/4 AB
205	Elbow-90°, 1/8 MNPT x 1/4 AB
206	Elbow-90°, 1/4 MNPT x 1/4 AB
207	Tee-Branch, 1/4 MNPT x 1/4 AB x 1/4 AB
214	Adapter-Straight, 4 MJIC X 12 MM
217	Hose Assembly-Oil Injection
218	Tee-Oil Return, 8 MJIC x 8 FJIC x 4 MJIC (90°)
222	Gasket-Outlet
223	Fitting-Oil Injection
224	Flange-Outlet
226	Elbow-90°, 1 MNPT x 16 MJIC
227	OS70 Compressor Bottom Outlet
231	Compressor Repair Kit
232	O-Ring, 3-7/8 X 4-1/4 in
235	Screw-Hex Hd, M16-2 x 30 mm
237	Washer-Flat, 8 mm
238	Washer-Flat, 16 mm
245	Sleeve-Internal Support
246	Screw-Soc Hd, M10-1.5 x 25 mm
247	Shaft Seal Repair Kit
900	PMC Subassembly (See Page 11)

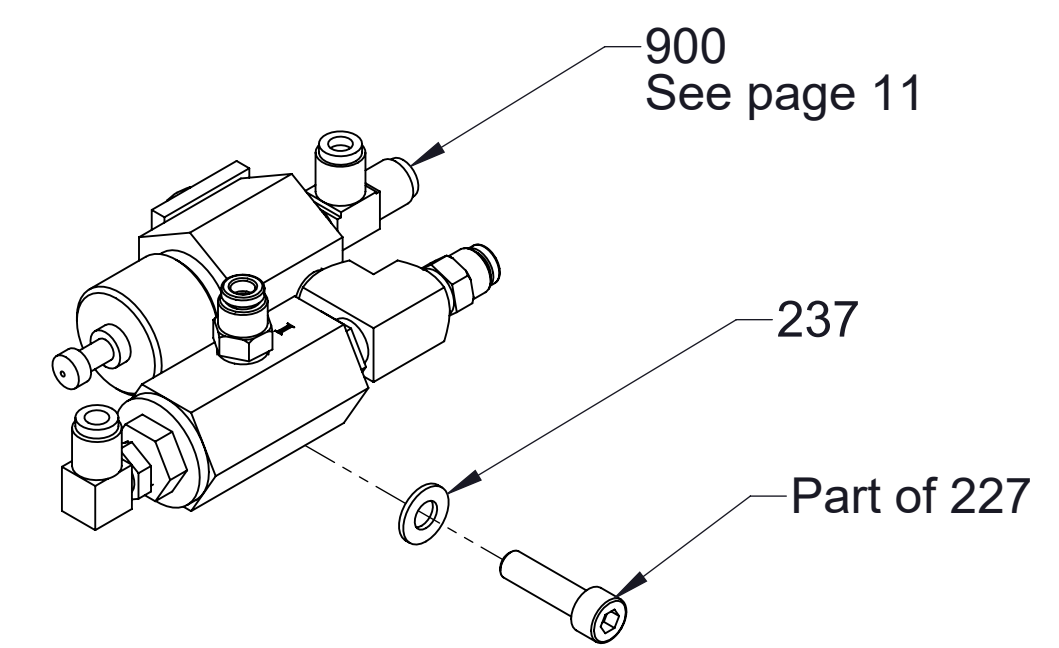

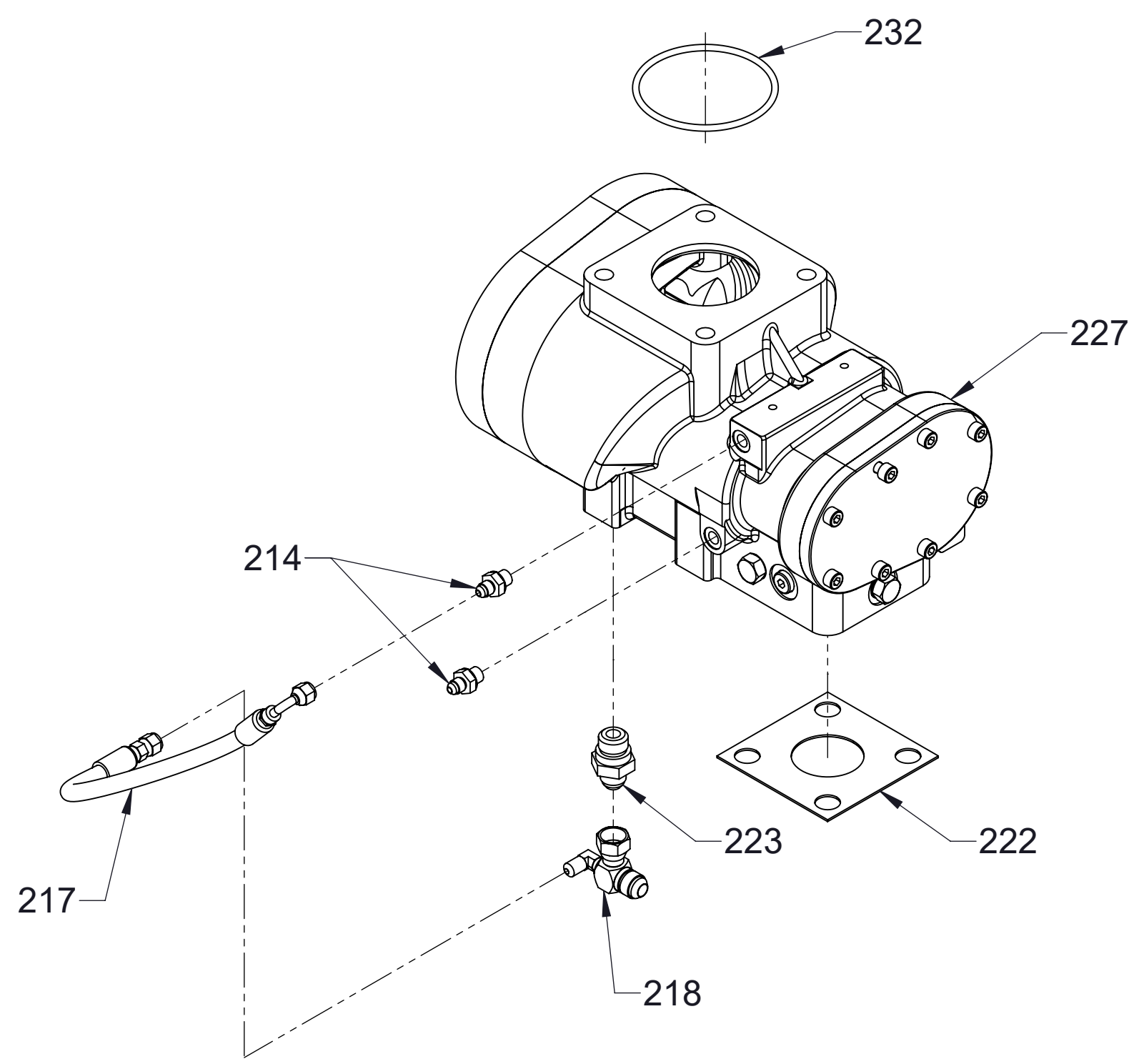

231

Compressor Replacement Kit

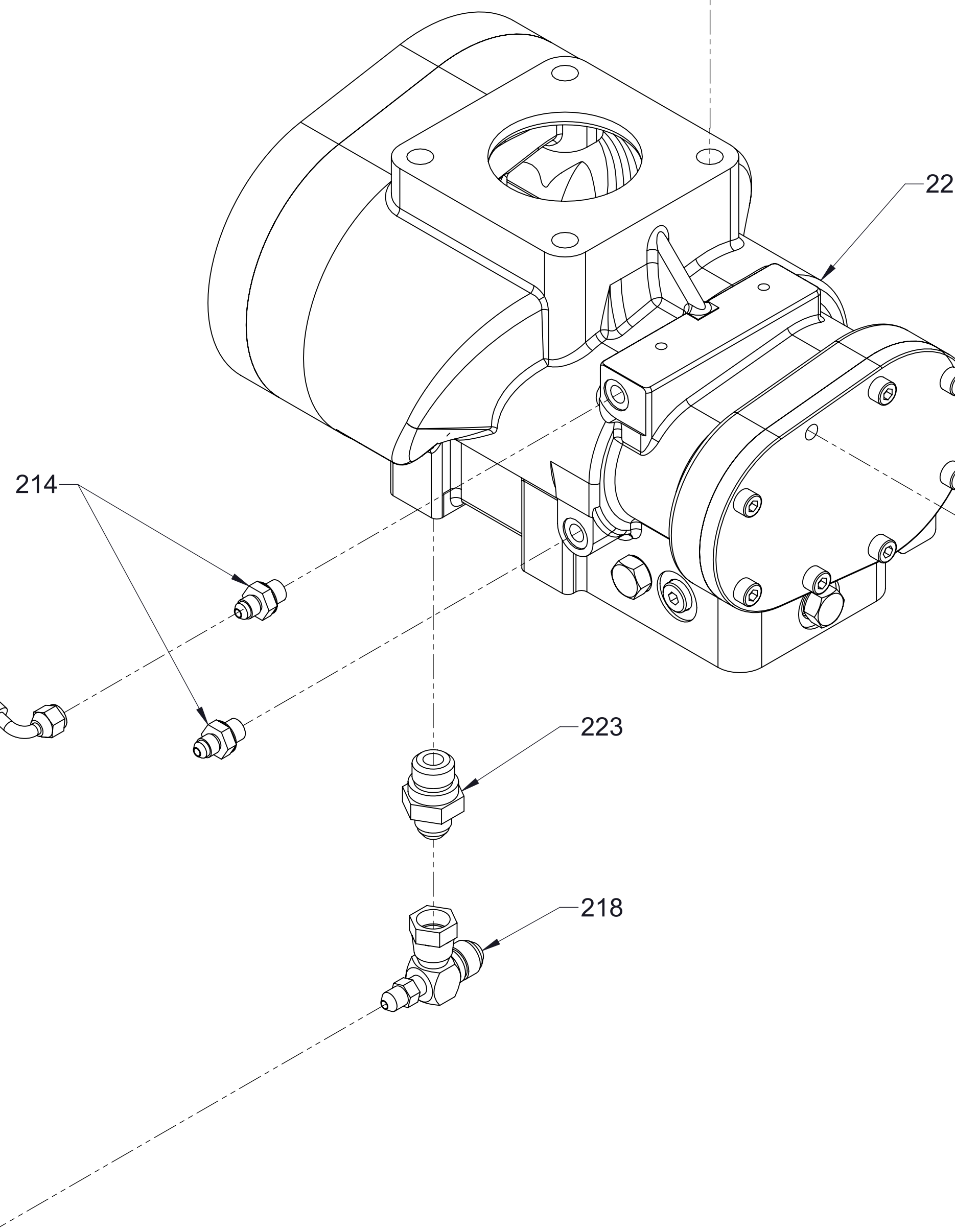
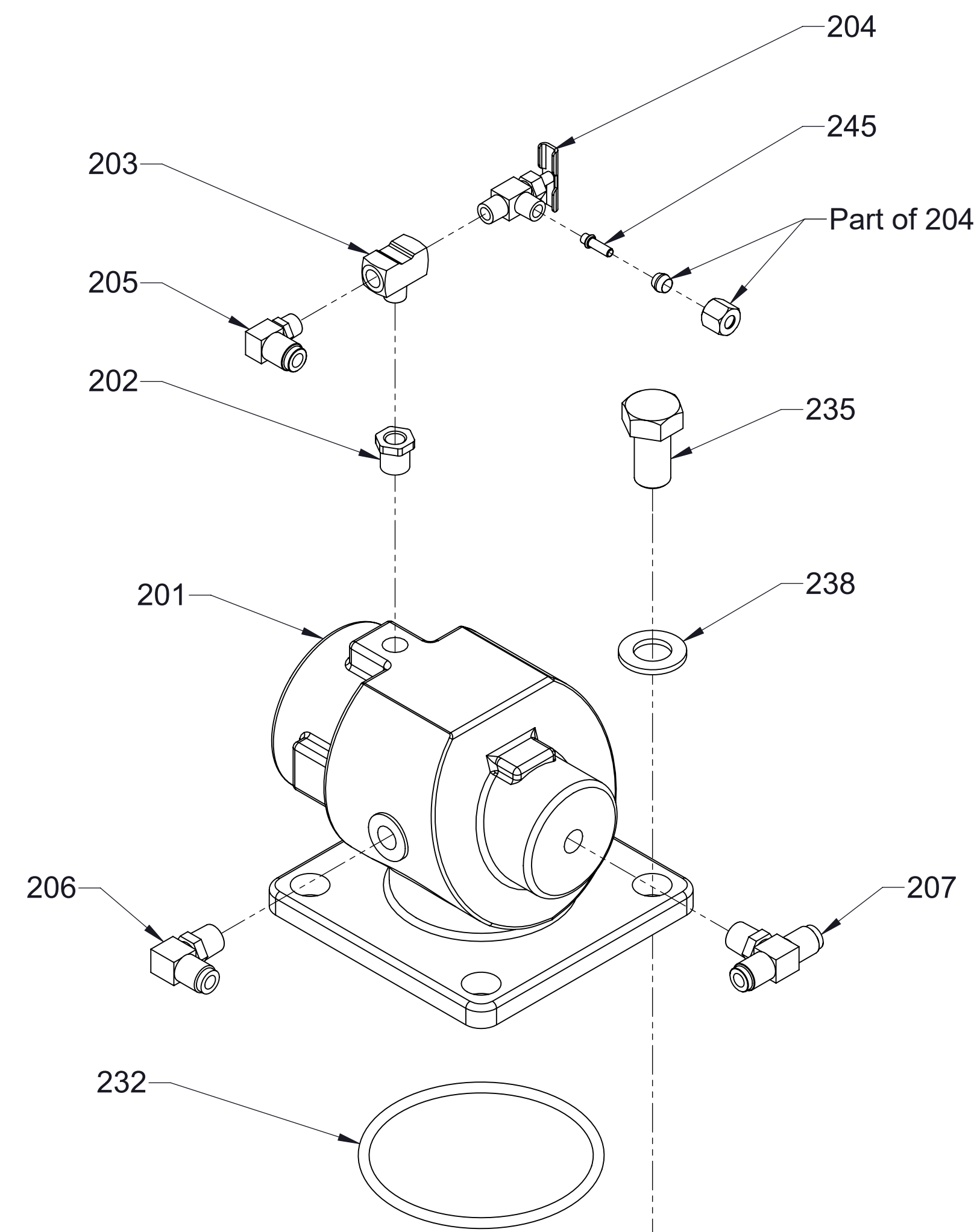

Compressor Subassembly
Models ending with 150-P, 150-PC, 150-ECL

Ref No.	Description
200	Compressor Subassembly (Includes 201-245 and 900)
201	Inlet-Air, 2-1/2 X 90°
202	1/4 X 1/8 Brass Bushing Reducing
203	Tee-Branch, 1/8 MNPT x 1/8 FNPT x 1/8 FNPT
204	Valve-Trim, 1/8 MNPT x 1/4 AB
205	Elbow-90°, 1/8 MNPT x 1/4 AB
206	Elbow-90°, 1/4 MNPT x 1/4 AB
207	Tee-Branch, 1/4 MNPT x 1/4 AB x 1/4 AB
214	Adapter-Straight, 4 MJIC X 12 MM
217	Hose Assembly, Oil Injection
218	Tee-Oil Return, 8 MJIC x 8 FJIC x 4 MJIC (90°)
222	Gasket-Outlet
223	Fitting-Oil Injection
227	End-Air, CF75D8
231	Compressor Repair Kit
232	O-Ring, 3-7/8 X 4-1/4 in
235	Screw-Hex Hd, M16-2 x 30 mm
237	Washer-Flat, 8 mm
238	Washer-Flat, 16 mm
245	Sleeve-Internal Support
247	Shaft Seal Repair Kit
900	PMC Subassembly (See Page 11)

200
Compressor Subassembly
(includes 201-245 and 900)

247
Shaft Seal Repair Kit

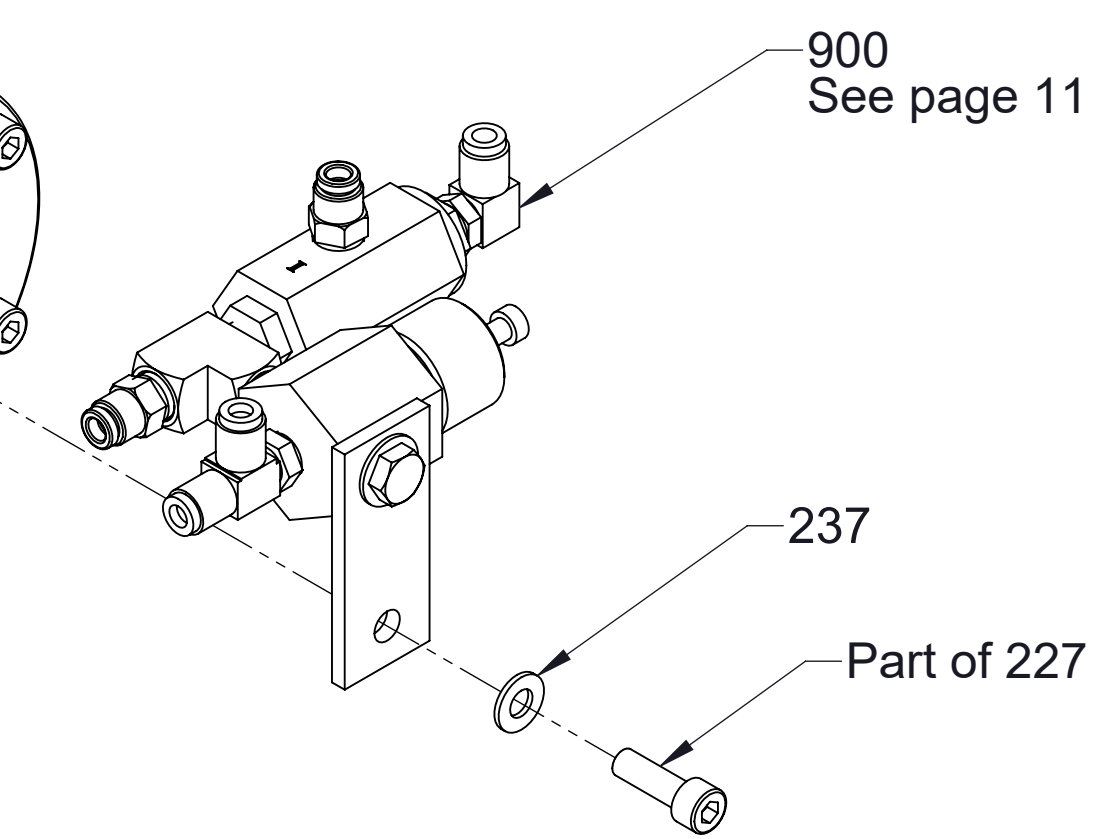

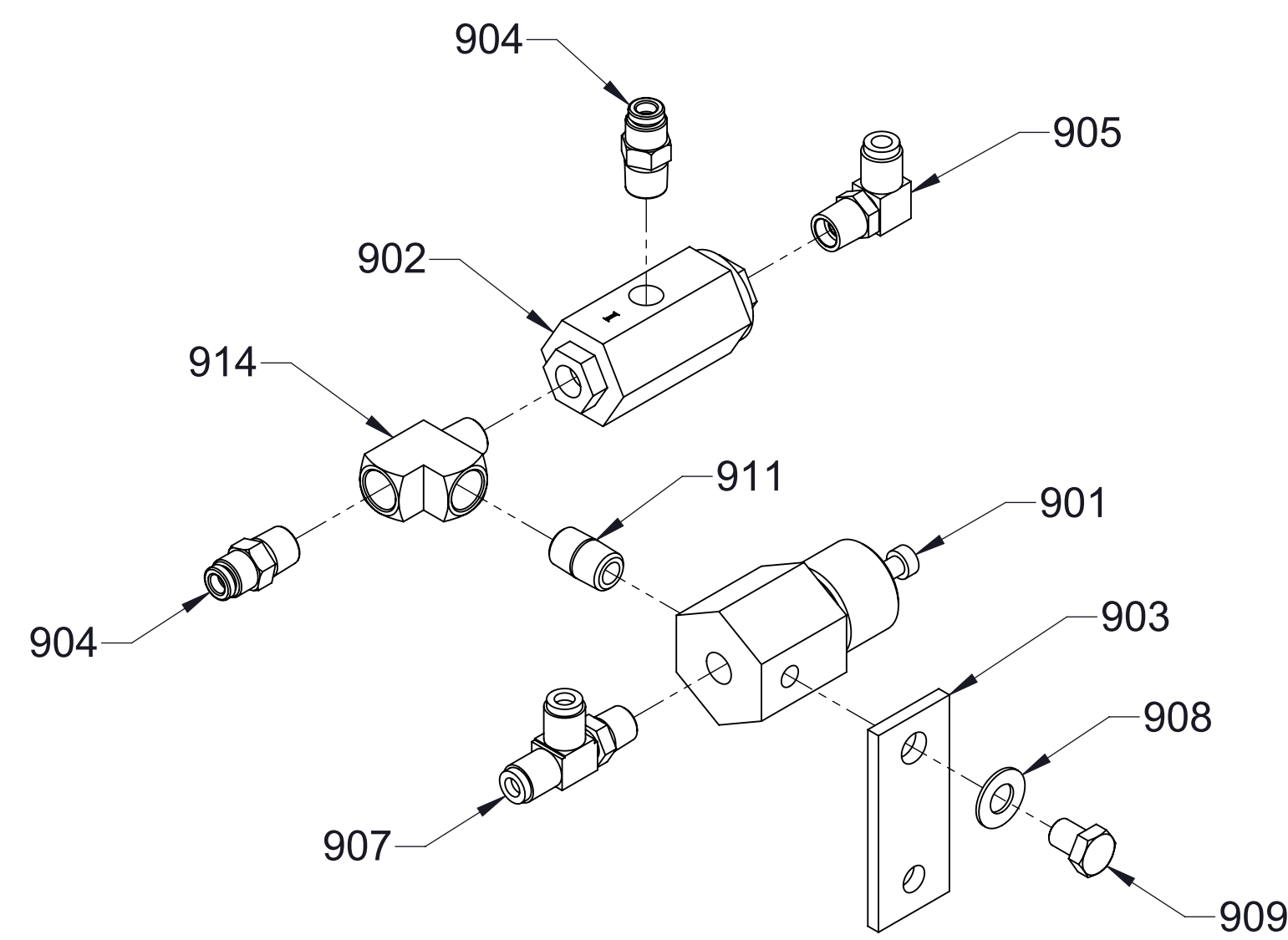

Models ending with 150-P

Ref No.	Description
901	Pressure Regulator
902	Valve-Blowdown
903	Bracket
904	Adapter-Straight, 1/4 MNPT x 1/4 AB
905	Elbow-90°, 1/4 MNPT x 1/4 AB
907	Tee-Branch, 1/4 AB x 1/4 MNPT x 1/4 AB
908	Washer-Plain, 3/8 in
909	Screw-Hex Hd, 3/8-16 x 1/2 in
910	Valve-Solenoid
911	Nipple-Pipe, 1/4 NPT x 7/8 in
912	Tee-Standard, Pipe, 1/4 NPT
914	Tee-Street, 1/4 NPT
N/AS	Label-Solenoid, High-Rise Pressure
N/AS	Label-Solenoid, Normal Pressure

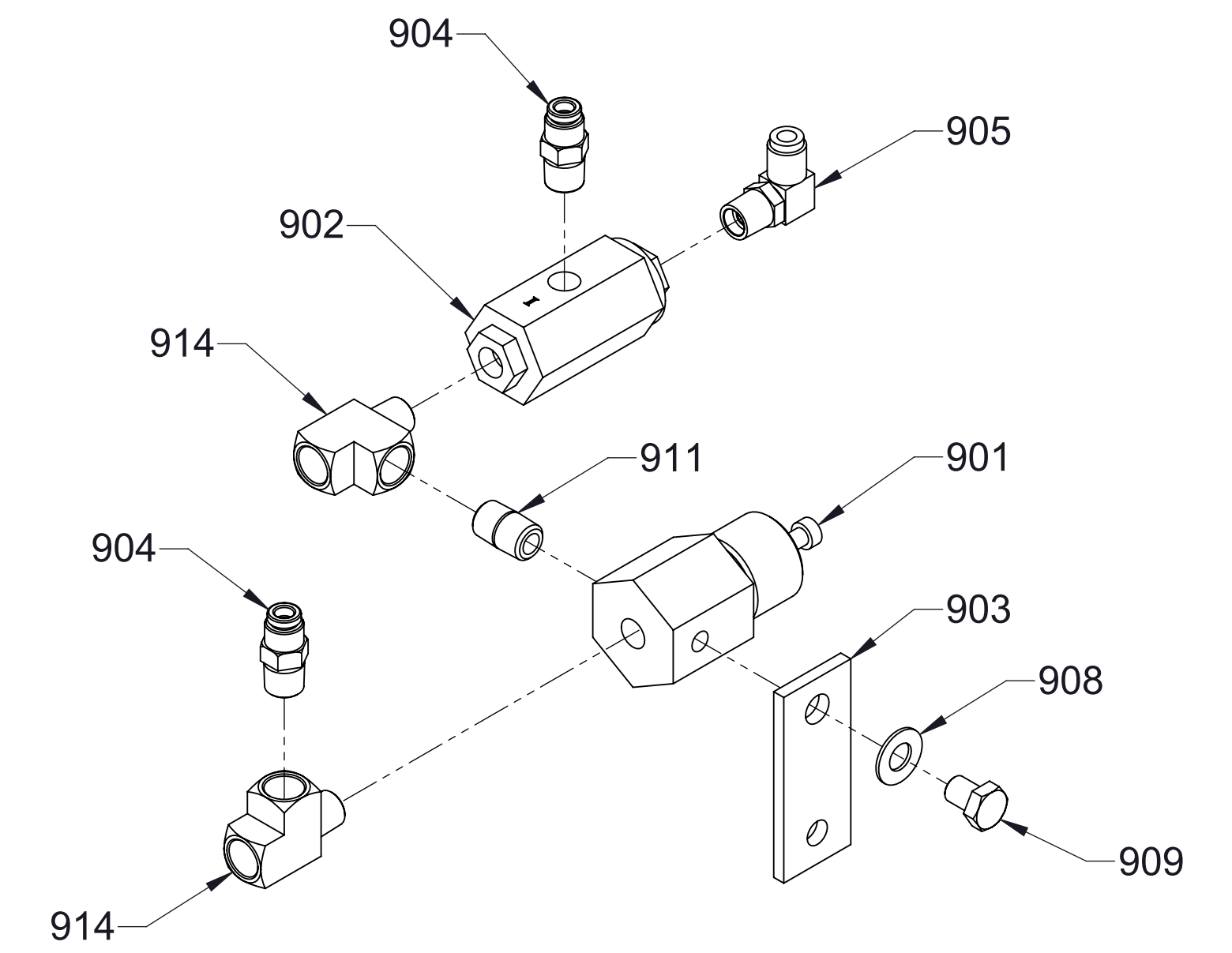

Models ending with 150-PC

Traditional CAFS

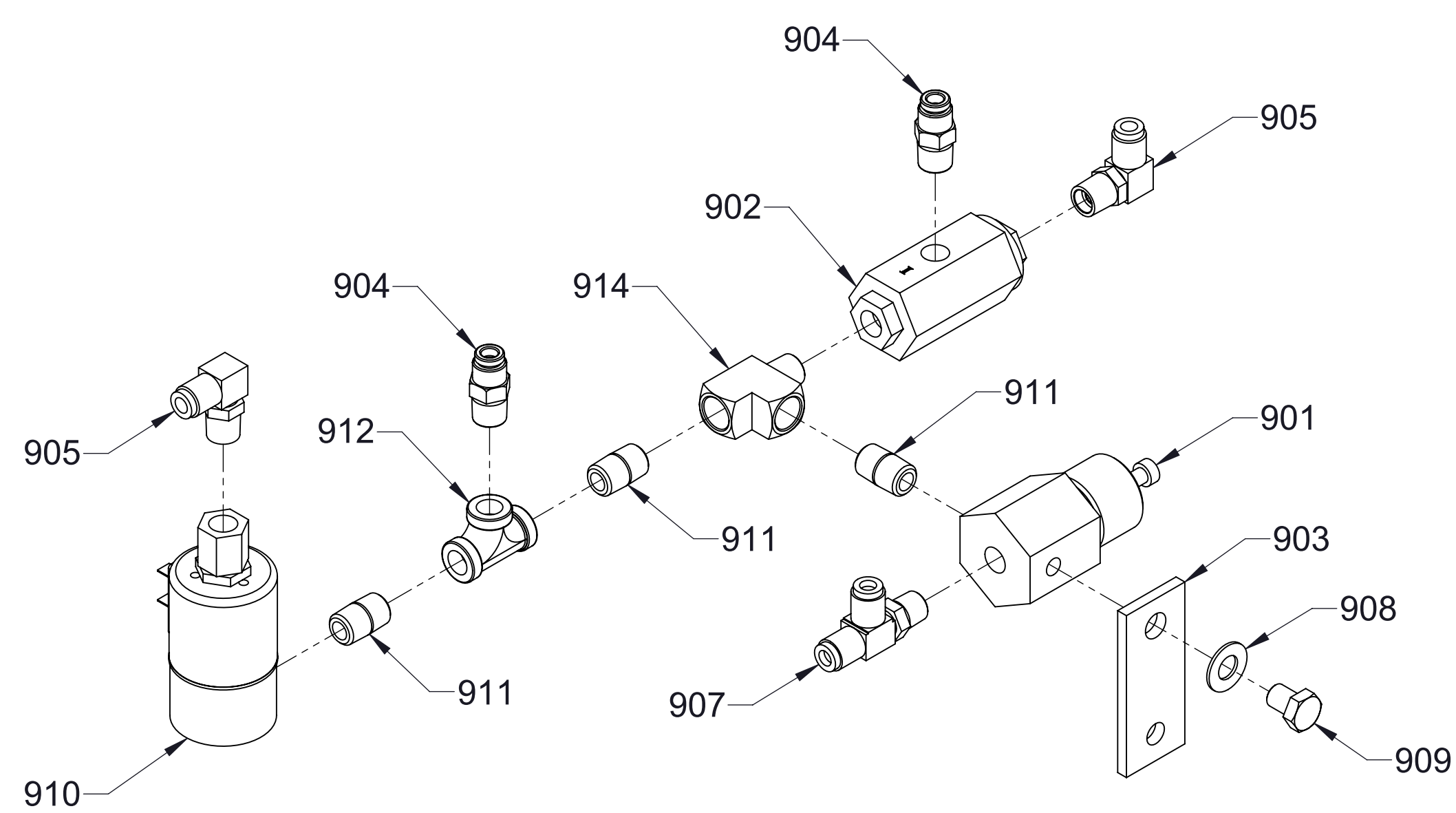

Without High-Rise Option

Eclipse GEN 2.0 CAFS
Models ending with 150-ECL

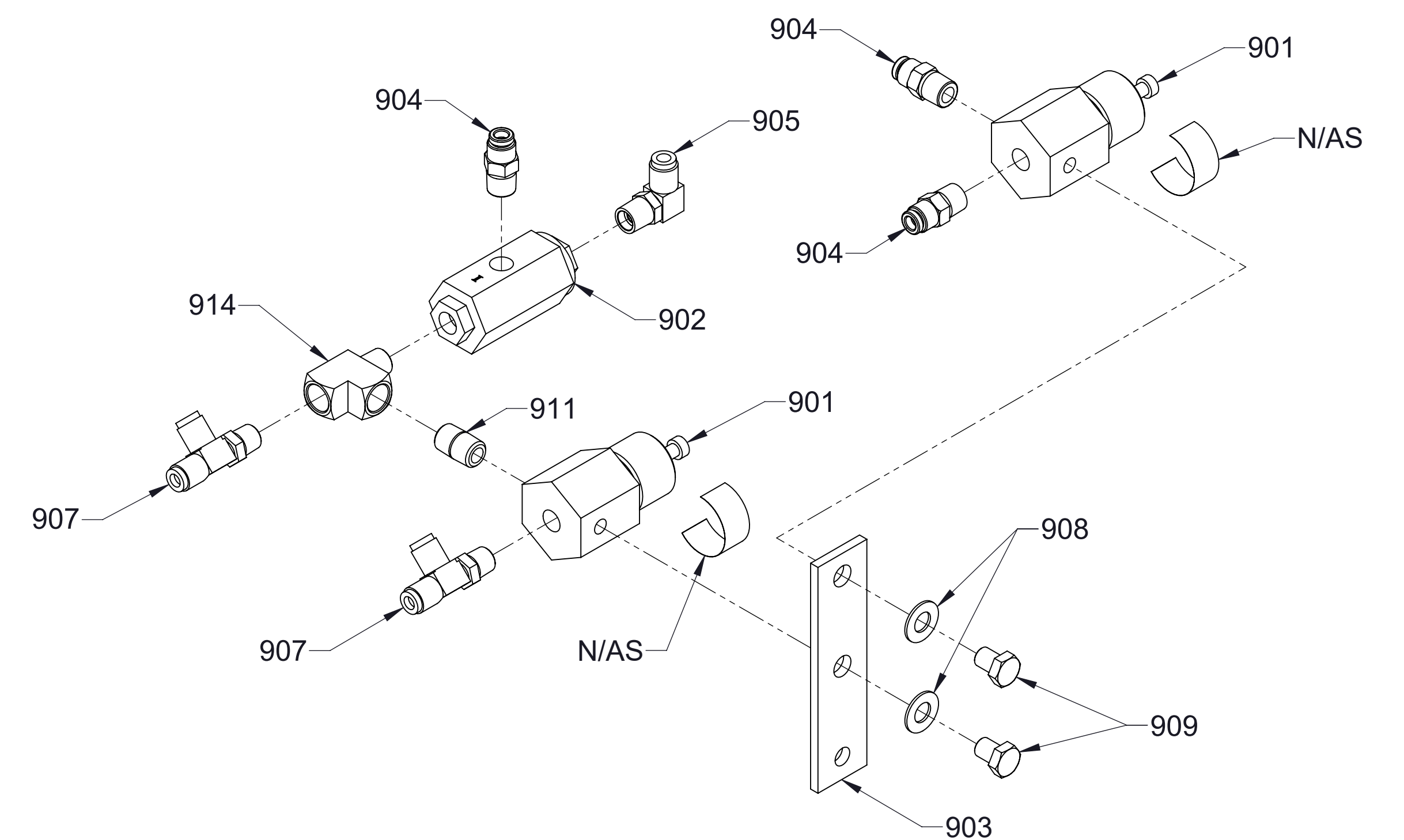

With High-Rise Option

Ref No.	Description
40	Filter - Air, 3 inch (CO85004)
41	Tube-Inlet Air-3 X 48 t
42	Clamp-HS 53 3-1/2
43	3IN T-BOLT
44	Elbow - Rubber 3 X 90°
200	Compressor Subassembly

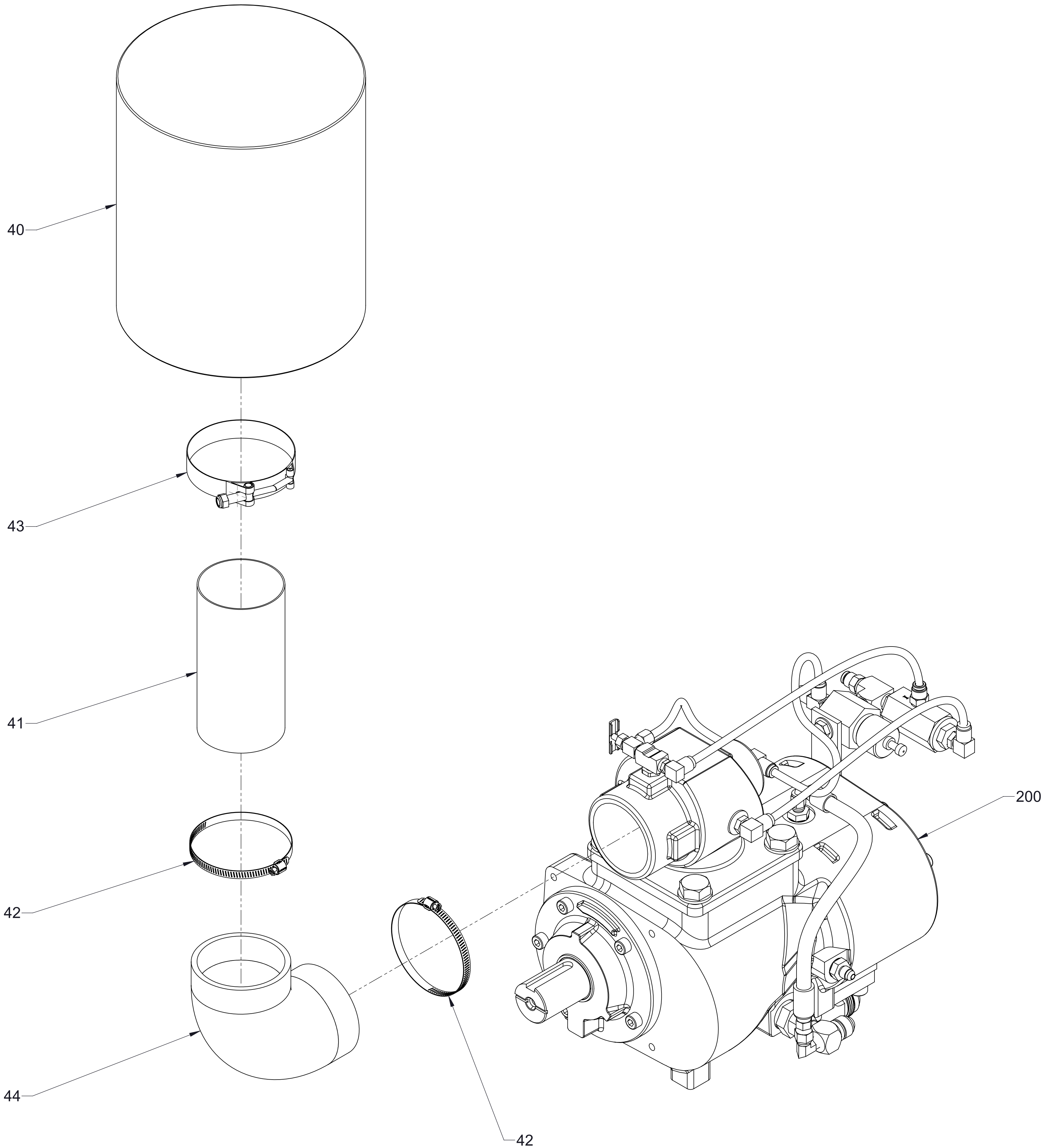

Air Filter

Note: Based on installation, configuration may vary from diagram

Ref No.	Description
45	Dual Scale Oil Temperature Gauge
46	Oil Temp Gauge to 24V Conversion Kit
60	Compressed Air Warning Plate
61	Hose Length Plate
100	Plate-Serial
325	Plate-Electric Auto-Sync
326	Harness-Switch, Electric Auto-Sync

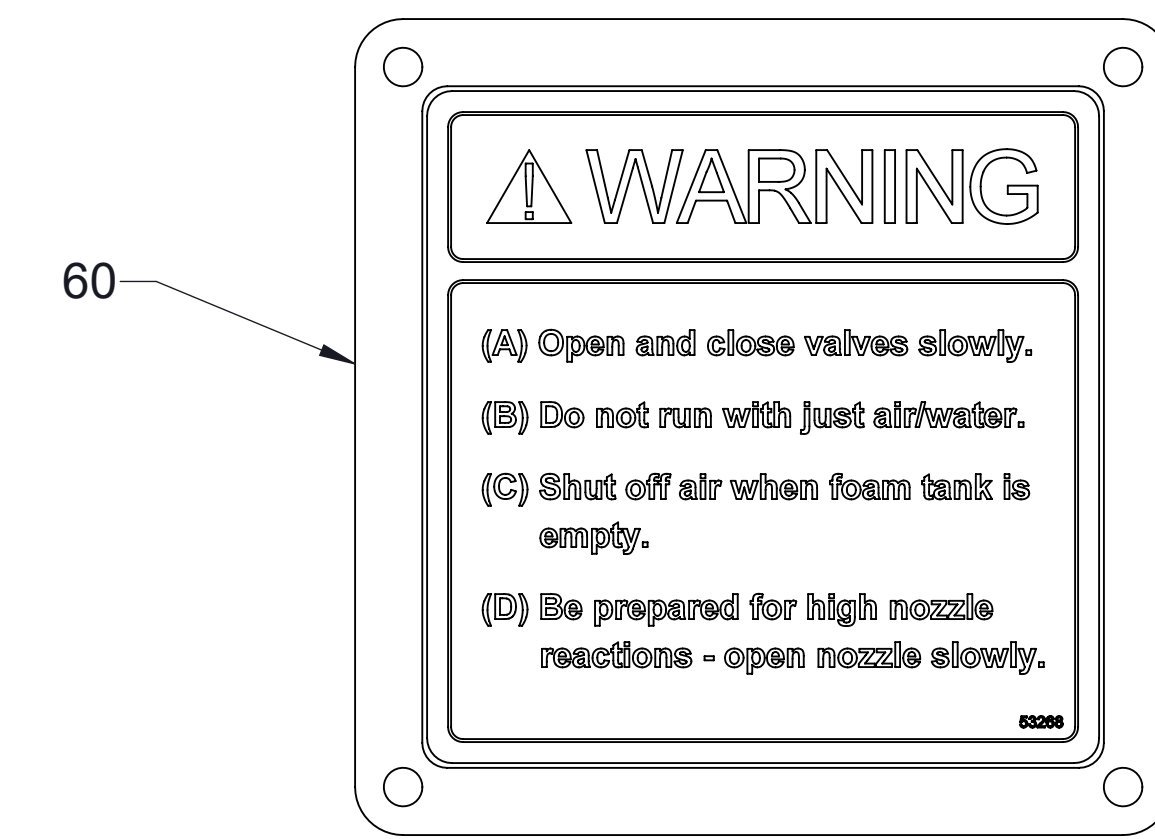
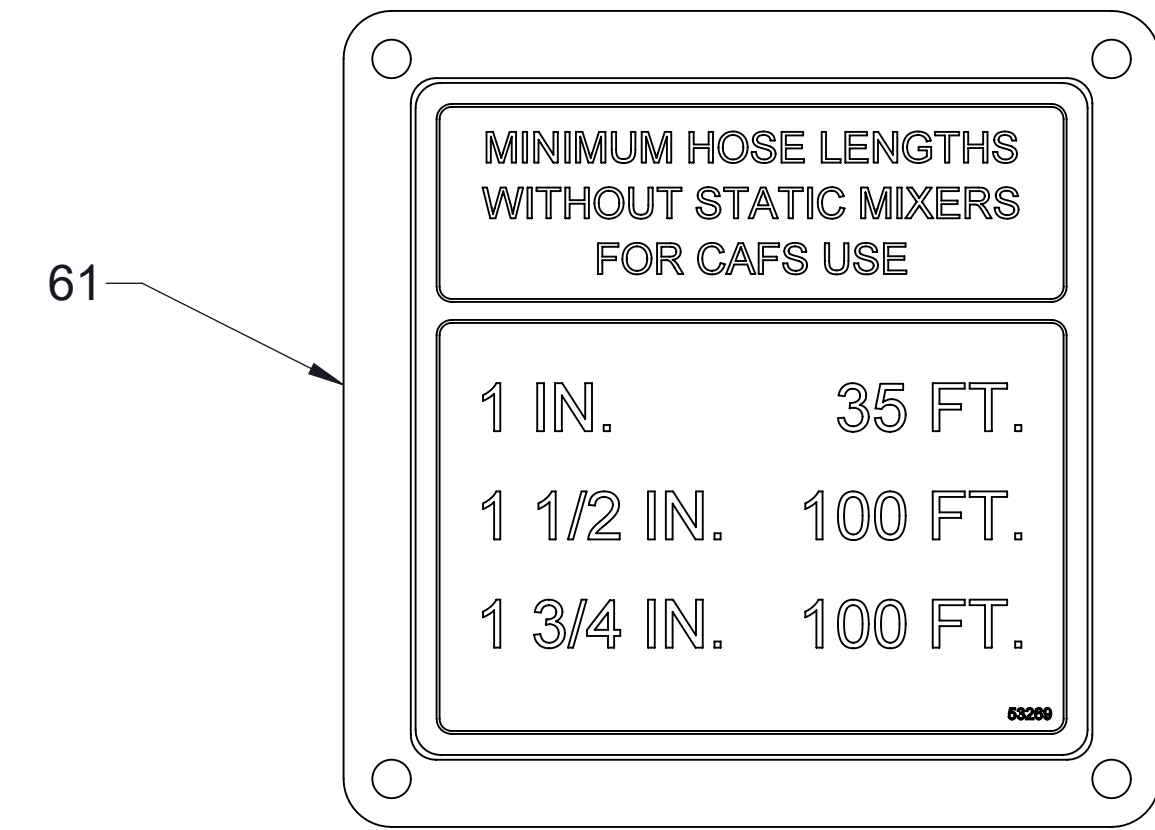
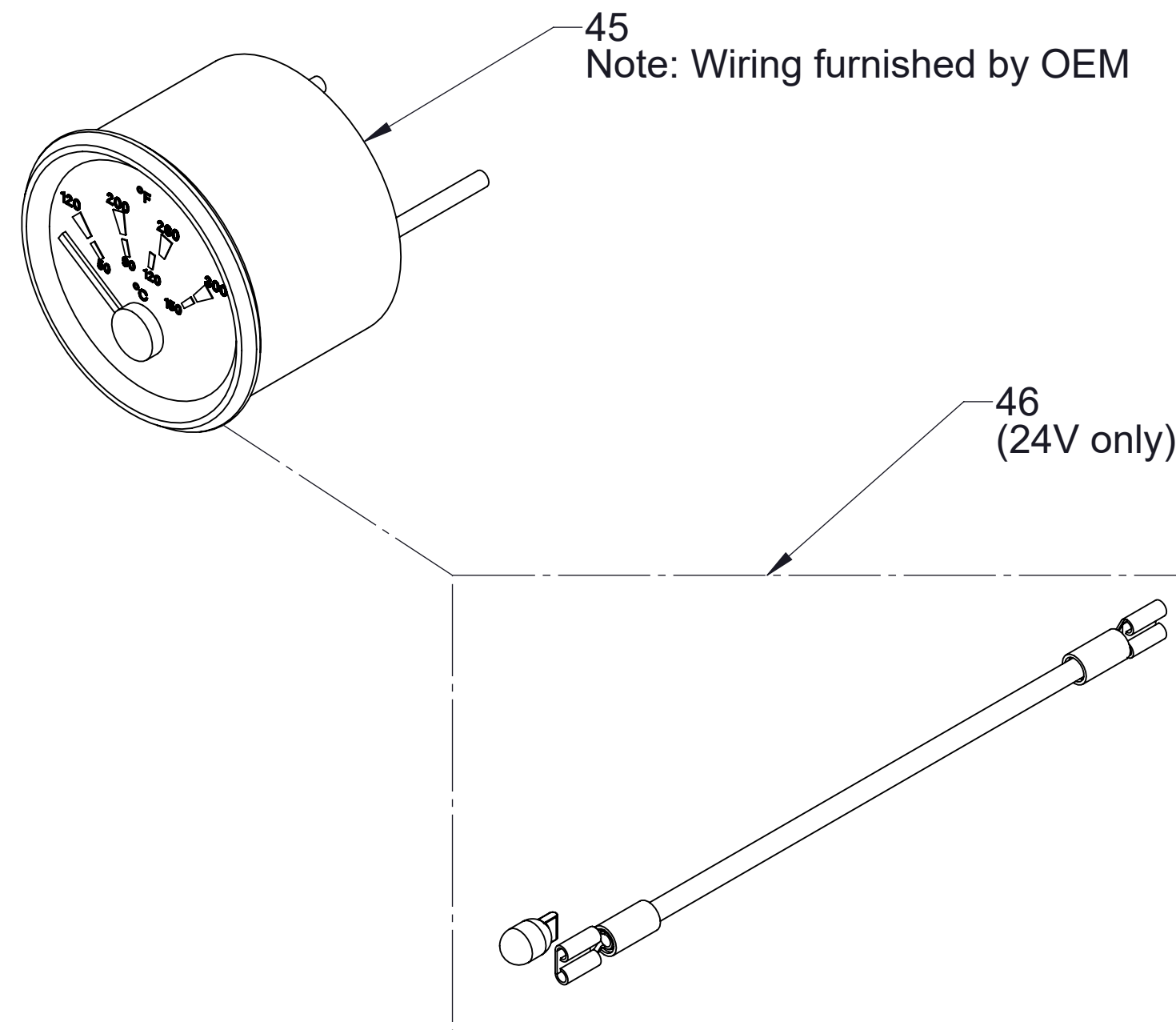
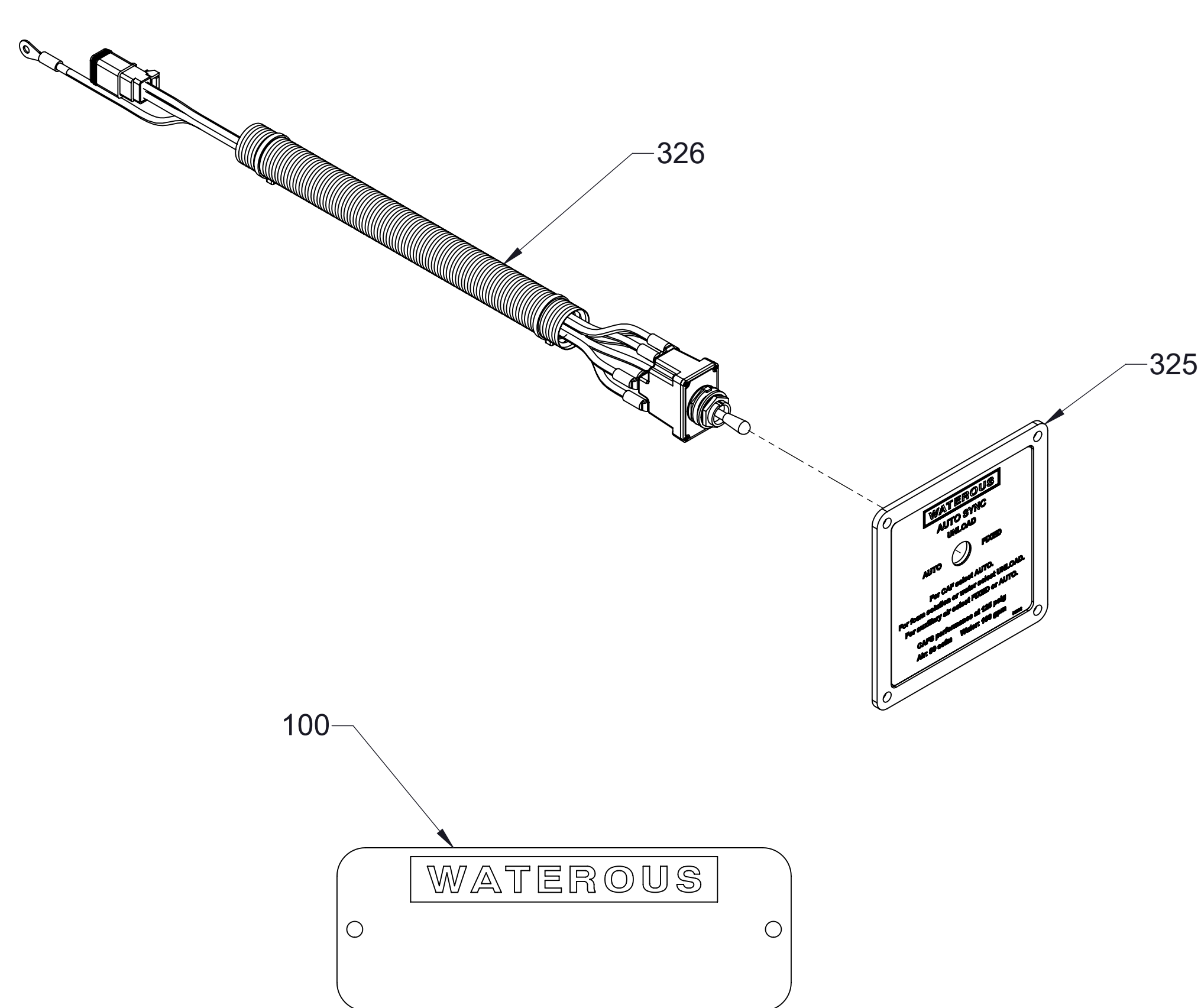

Traditional CAFS

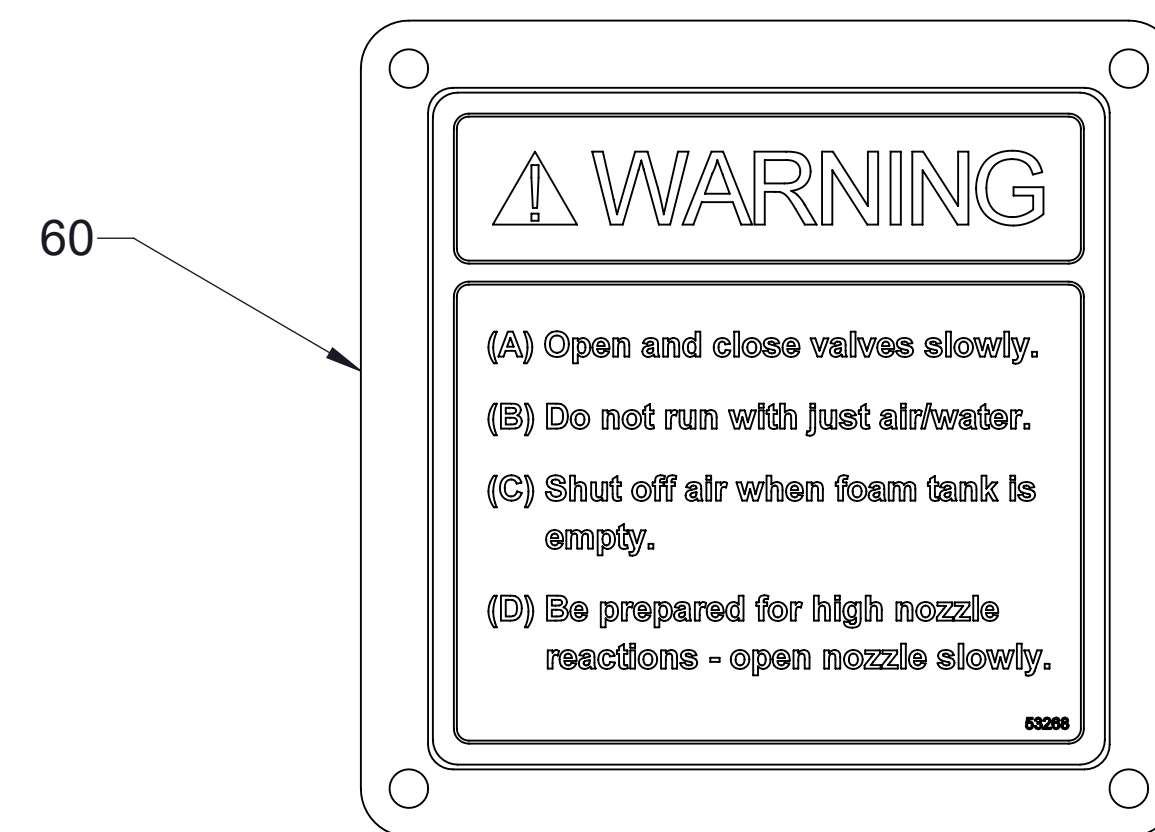
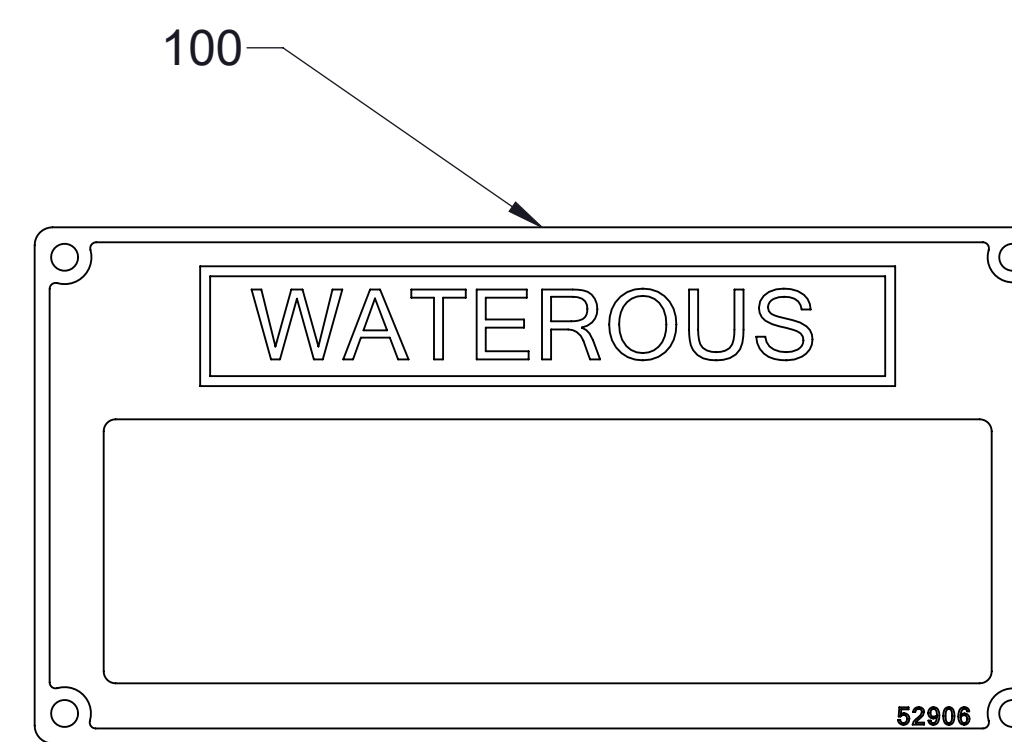
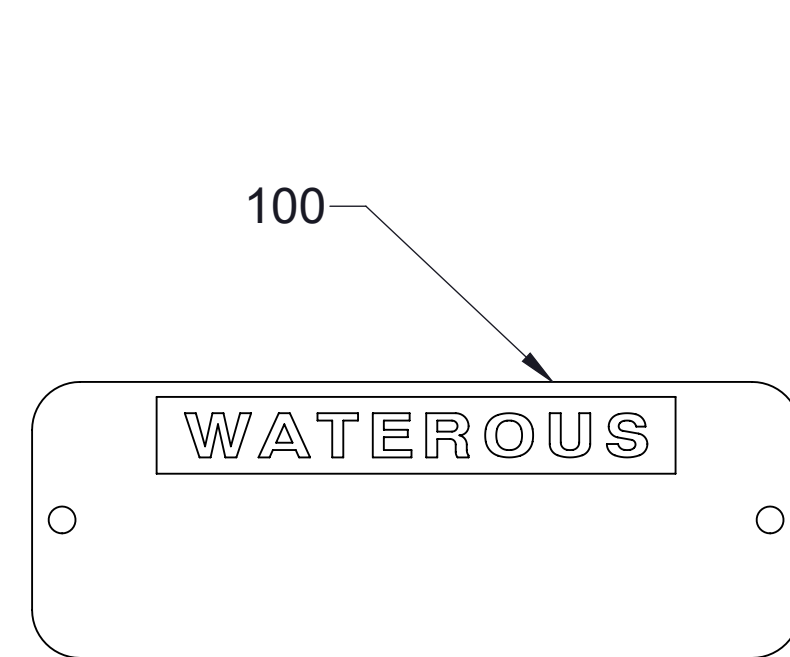

Eclipse GEN 2.0 CAFS

Panel Components

Ref No.	Description
63	Black Air Brake Tube, 1/4 in. x 180 in. Long (Cut to Suit Application)
64	Red Air Brake Tube, 1/4 in. x 120 in. Long (Cut to Suit Application)
65	Yellow Air Brake Tube, 1/4 in. x 120 in. Long (Cut to Suit Application)
228	Red Tubing-Air Brake, 1/4 in. x 24 in. (Cut to Suit Application)
229	Blue Tubing-Air Brake, 1/4 in. x 24 in. (Cut to Suit Application)
230	Green Tubing-Air Brake, 1/4 in. x 24 in. (Cut to Suit Application)

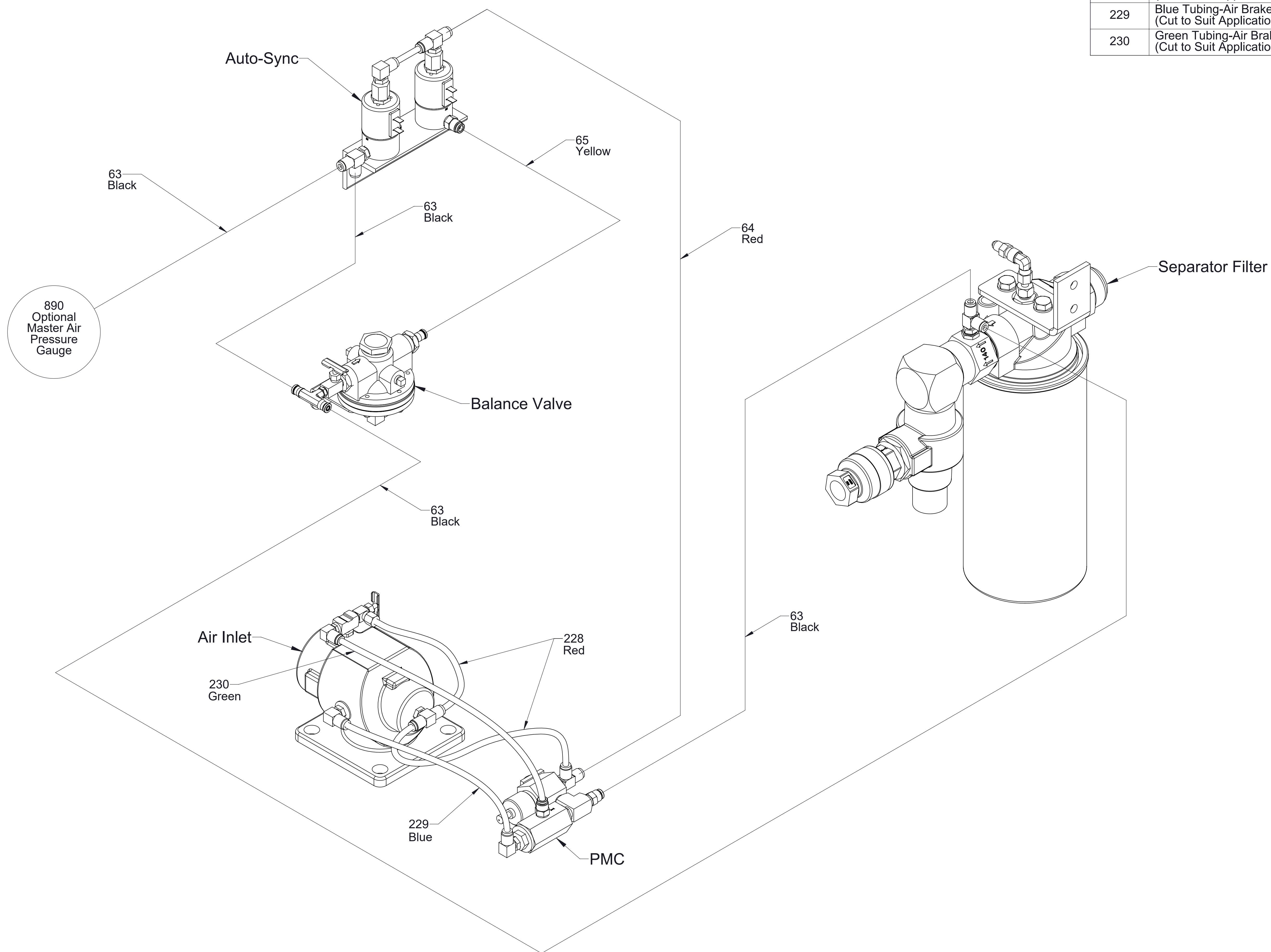

Schematic-Air
 Traditional CAFS
 Models ending with 100-P, 120-P, 150-P

Ref No.	Description
63	Black Tubing-Air Brake, 1/4 in. x 180 in. (Cut to Suit Application)
228	Red Tubing-Air Brake, 1/4 in.x 24 in. (Cut to Suit Application)
229	Blue Tubing-Air Brake, 1/4 in. x 24 in. (Cut to Suit Application)
230	Green Tubing-Air Brake, 1/4 in. x 24 in. (Cut to Suit Application)

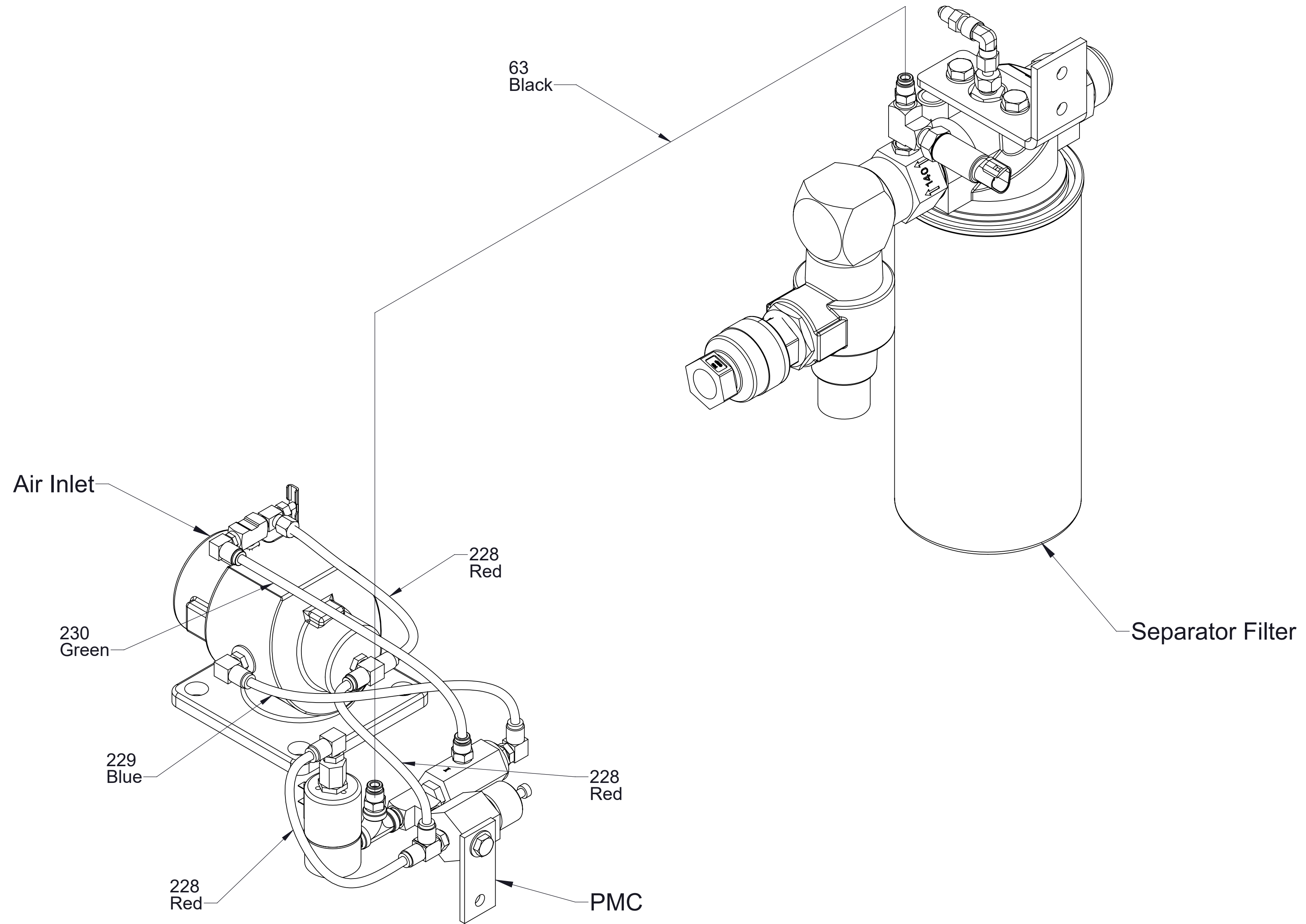

Schematic-Air
Generated CAFS
Models ending with 150-ECL, without High-Rise option

Ref No.	Description
63	Black Tubing-Air Brake, 1/4 in. x 180 in. (Cut to Suit Application)
64	Red Tubing-Air Brake, 1/4 in. x 120 in. (Cut to Suit Application)
65	Yellow Tubing-Air Brake, 1/4 in. x 120 in. (Cut to Suit Application)
228	Red Tubing-Air Brake, 1/4 in. x 24 in. (Cut to Suit Application)
229	Blue Tubing-Air Brake, 1/4 in. x 24 in. (Cut to Suit Application)
230	Green Tubing-Air Brake, 1/4 in. x 24 in. (Cut to Suit Application)

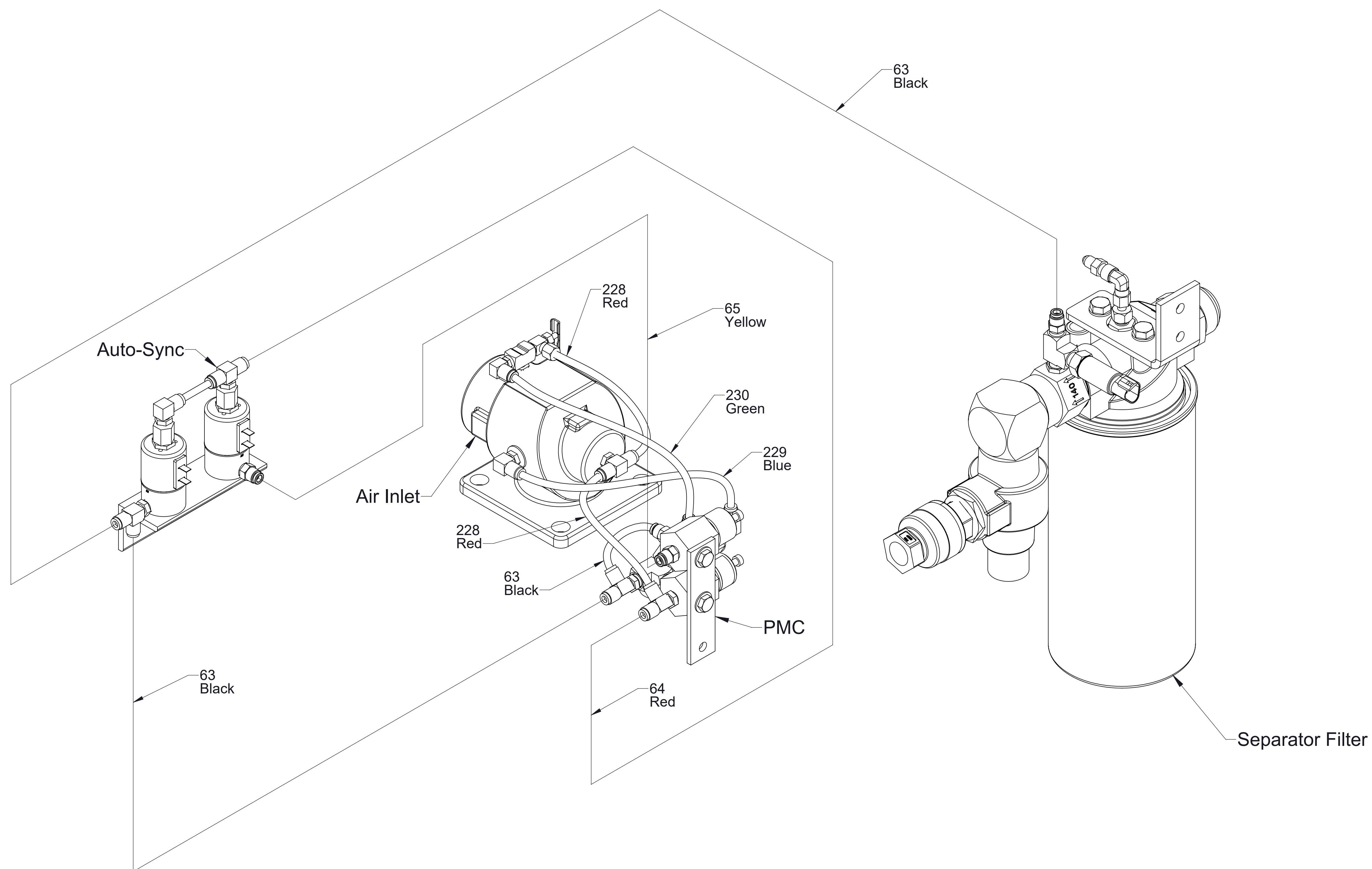

Schematic-Air
Generated CAFS
Models ending with 150-ECL, with High-Rise option

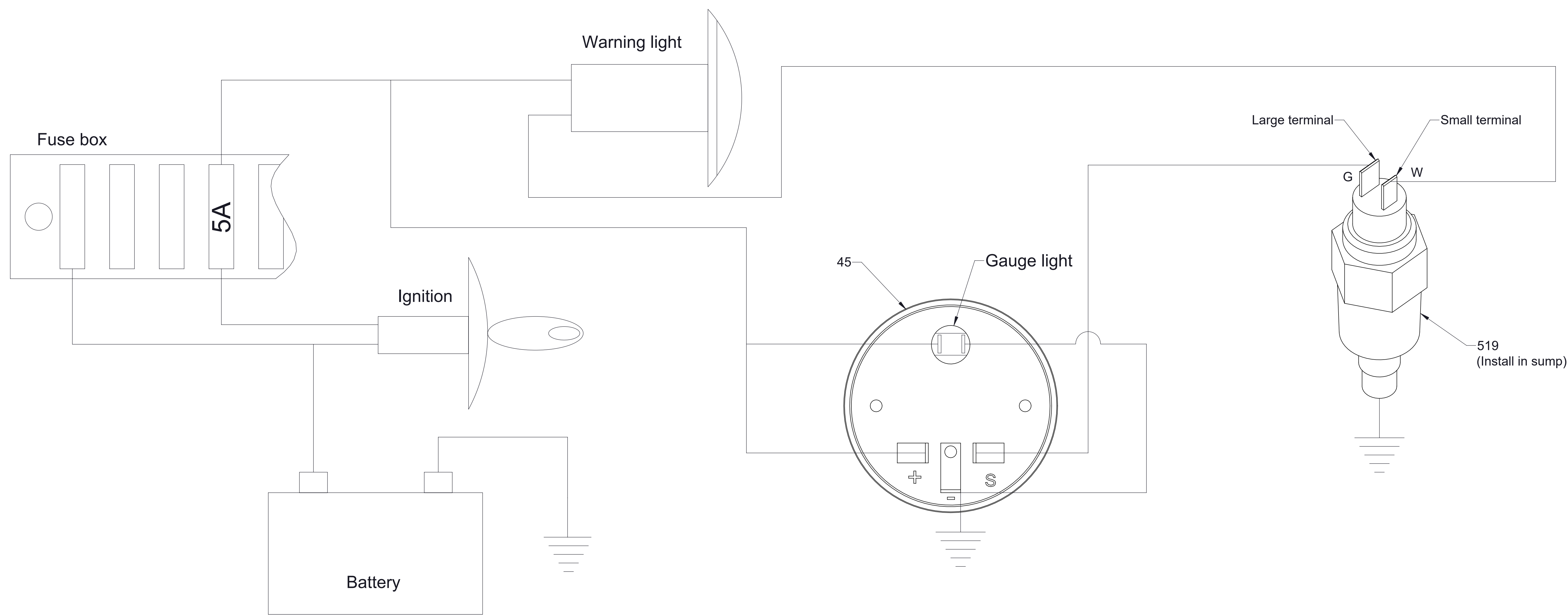

Note: Typical installation, all wiring, warning light, fuse, ignition switch and battery furnished by OEM

Sump Temperature Sender and Oil Temperature Gauge

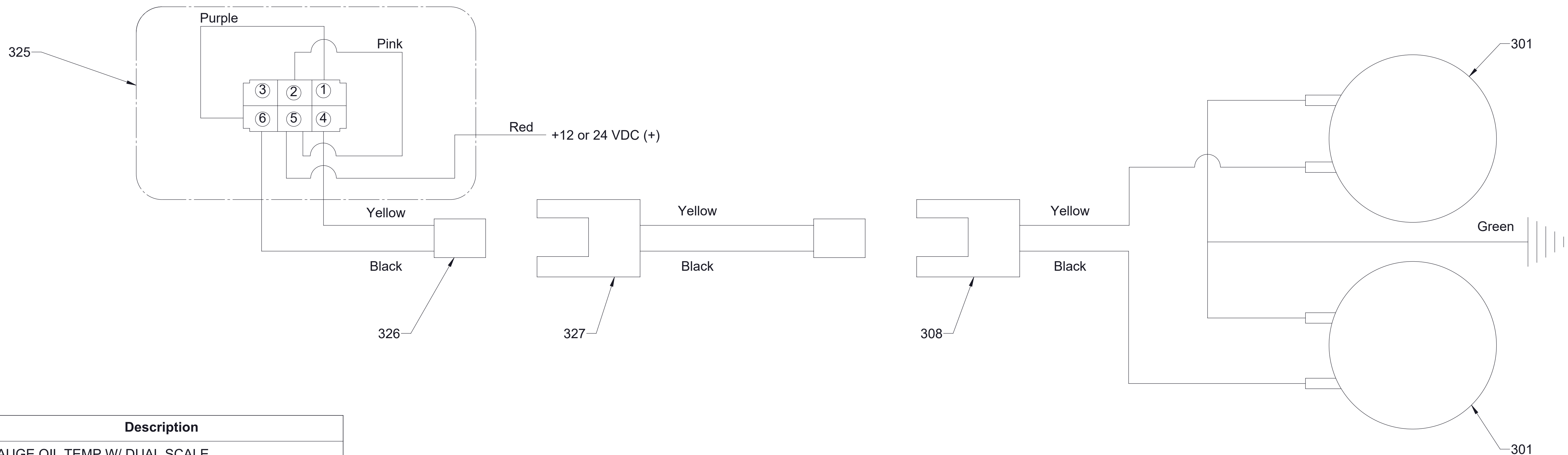

Ref No.	Description
45	GAUGE OIL TEMP W/ DUAL SCALE
301	Solenoid Valve
308	Electric Auto-Sync Wiring Harness
325	Electric Auto-Sync Plate
326	Electric Auto-Sync Switch Harness
327	Harness-Extension, Auto-Sync, 15 Feet
519	TEMP SENDER VDO 323-010

Auto-Sync Panel and Solenoids

Schematic-Electrical
 Traditional CAFS
 For Generated CAFS see Foam Generator Service Parts List