

## Advantus™ Foam System Service Parts List Model Advantus 6

Index:

Component		See Pages
Foam Pump	Complete Unit	2, 3
	Pump and Motor	4, 5
	Bracket and Control Module	6, 7
	Control Box Wiring	8, 9
Foam Manifold	Components	10, 11
	Cables	12, 13
Panel Components		14, 15
Foam Tank		16, 17
Foam Supply and Inject/By-Pass Hose Kits		See Service Parts List SPL83430
Dual Foam Tank Selector Kit		See Service Parts List SPL83440
Dual OIT Kit		See Service Parts List SPL83459

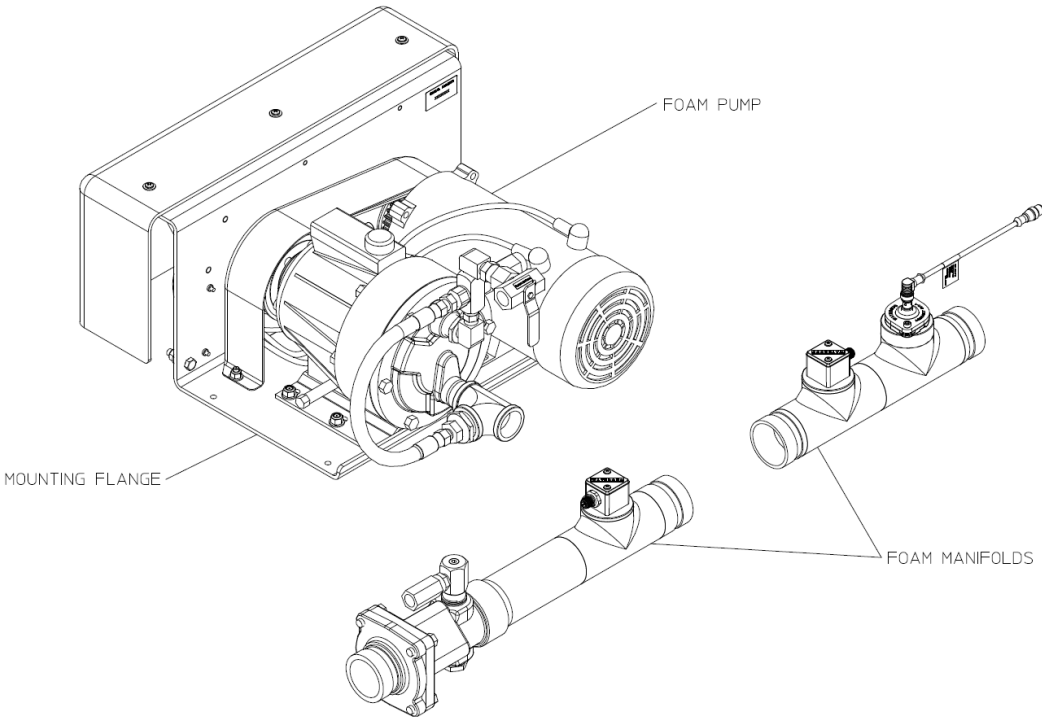

## Foam Pump – Complete Unit

REF NO.	DESCRIPTION
100	Foam Pump Cover
101	Cover Label
102	Pan Head Screw, No. 10-32 x 1/2 in.

REF NO.	DESCRIPTION
103	Plain Washer, No. 10
200	Foam Pump Assembly (Includes 201 thru 273)

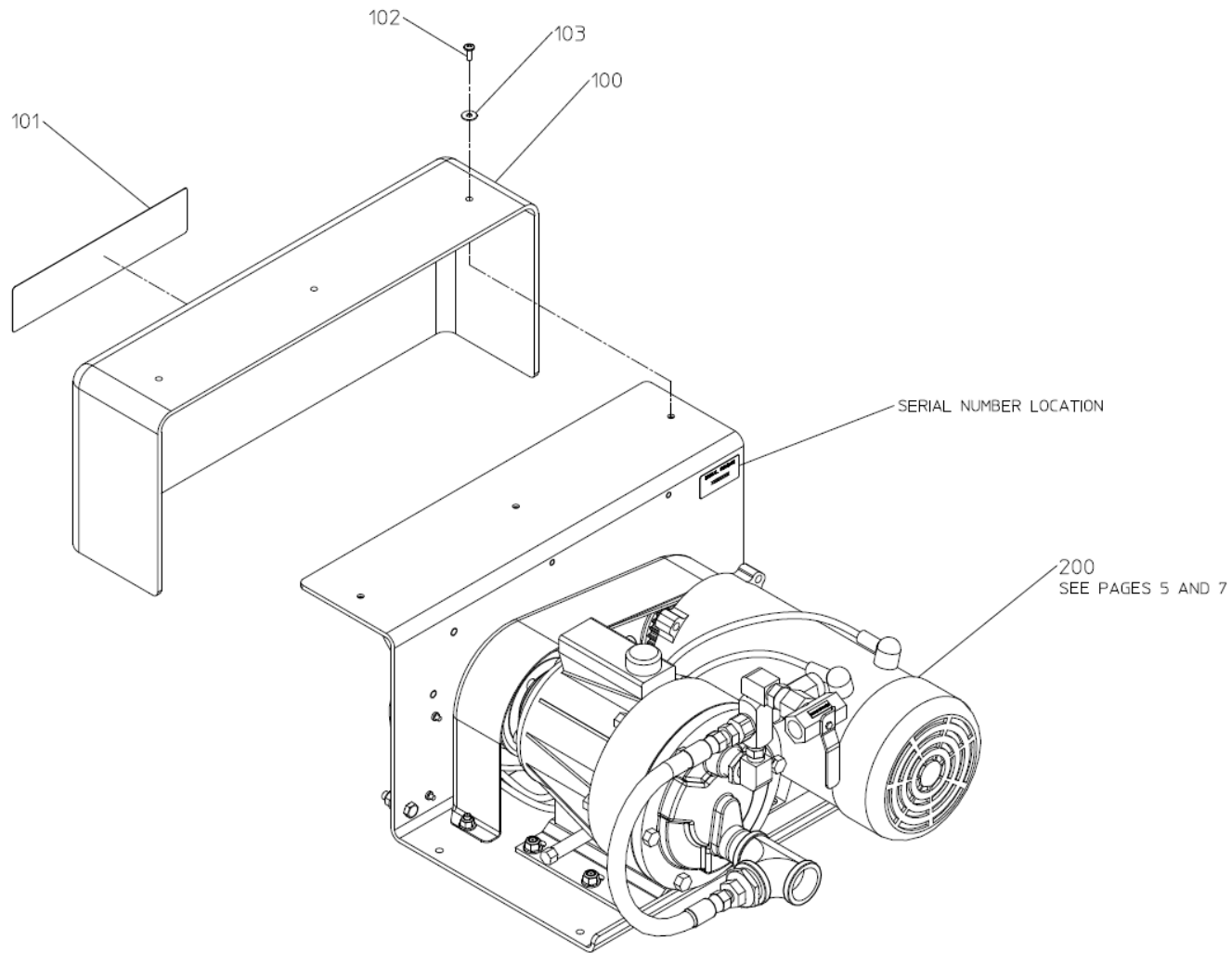

## FOAM PUMP – COMPLETE UNIT

## Foam Pump – Pump and Motor

REF NO.	DESCRIPTION
112	Wye Strainer, 1 in. (Includes 113 and 123)
113	Strainer Screen
123	Strainer Gasket
201	Straight Adapter, 3/8 MNPT x 3/8 MNPT
202	Straight Adapter, 6 MJIC x 1/2 MNPT
203	Street Elbow, 90 Deg., 3/8 NPT
205	Straight Adapter, 6 MJIC x 3/8 MNPT
206	Straight Adapter, 3/8 MNPT x 1/2 MNPT
207	Black Boot
208	Red Boot
210	Bypass Hose
215	3 Way Ball Valve
216	Pressure Regulator
217	Product Sensor
220	Electric Motor
222	Product Sensor Cable
223	Foam Pump (Includes 237)
228	Plain Washer, 1/4 in.

REF NO.	DESCRIPTION
229	Plain Washer, 5/16 in.
233	Nylok Hex Nut, 1/4-20
234	Nylok Hex Nut, 5/16-18
237	Vented Oil Fill Cap
238	Belt Guard
262	Reducing Bushing, 3/4 MNPT x 3/8 FNPT
263	Reducing Bushing, 1 MNPT x 1/2 FNPT
264	Close Pipe Nipple (Brass), 1 in. NPT
265	Tee, 1 FNPT x 1 FNPT x 1 FNPT
268	Belt
269	Speed Sensor Bracket
270	Pump Sprocket
271	Motor Sprocket
272	Taperlock Bushing, 7/8 in.
273	Taperlock Bushing, 5/8 in.
275	Hex Head Screw, M10-1.75 x 20mm
276	Lock Washer, 10mm
277	Foam Pump Rebuild Kit

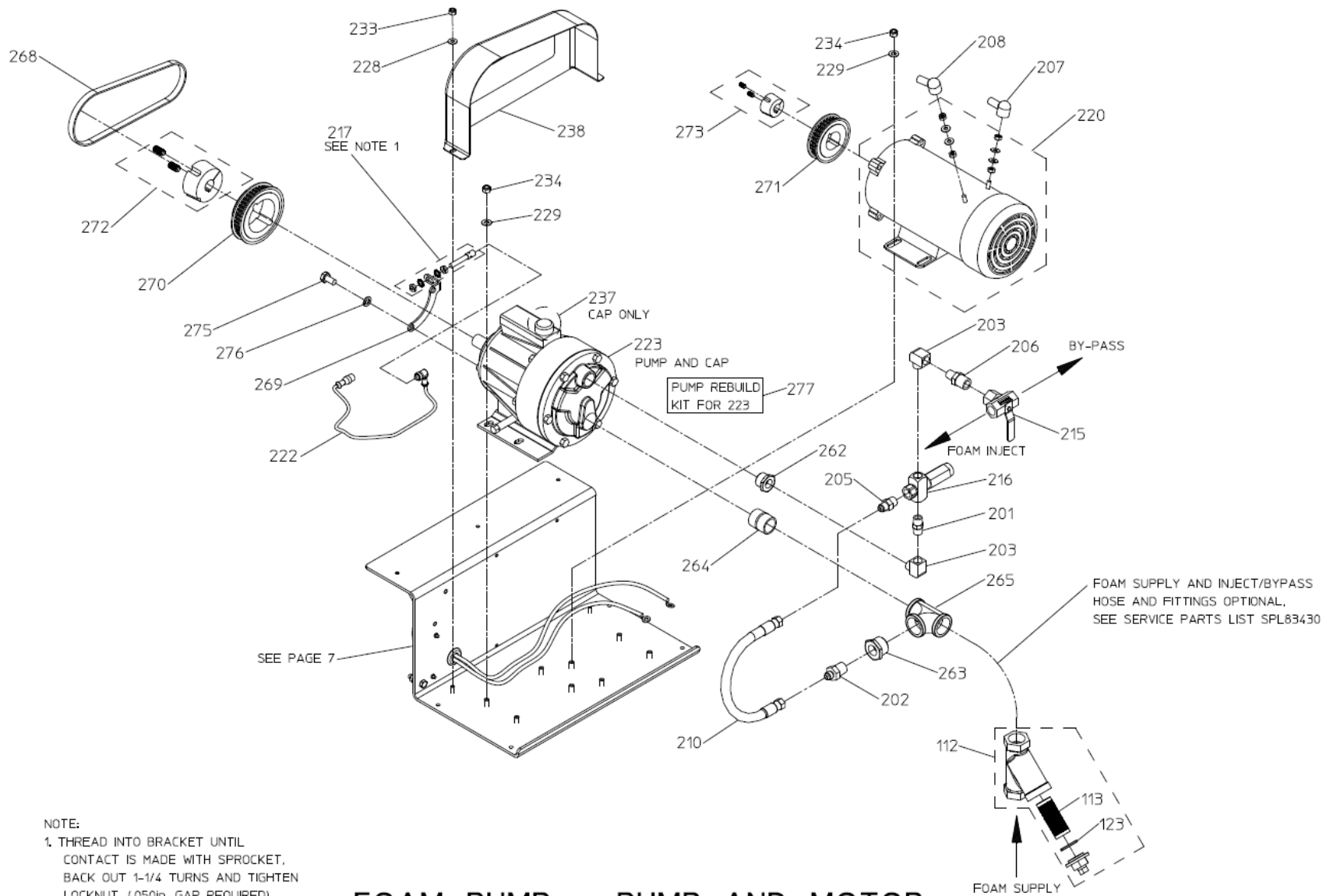

## FOAM PUMP – PUMP AND MOTOR

## Foam Pump – Bracket and Control Module

REF NO.	DESCRIPTION
209	Grommet
211	Z Bracket
218	8 Position Terminal Block
219	Number Strip
221	Control Box
224	Circuit Breaker
227	Hex Head Screw, 5/16-18 x 1-1/4 in.
228	Plain Washer, ¼ in.
229	Plain Washer, 5/16 in.

REF NO.	DESCRIPTION
231	Screw-Pan Head, No. 8-32 x ¾ in.
232	Plain Washer, No. 10
233	Nylok Hex Nut, ¼-20
234	Nylok Hex Nut, 5/16-18
236	Nylok Hex Nut, No. 10-32
274	Hex Nut, 5/16-18

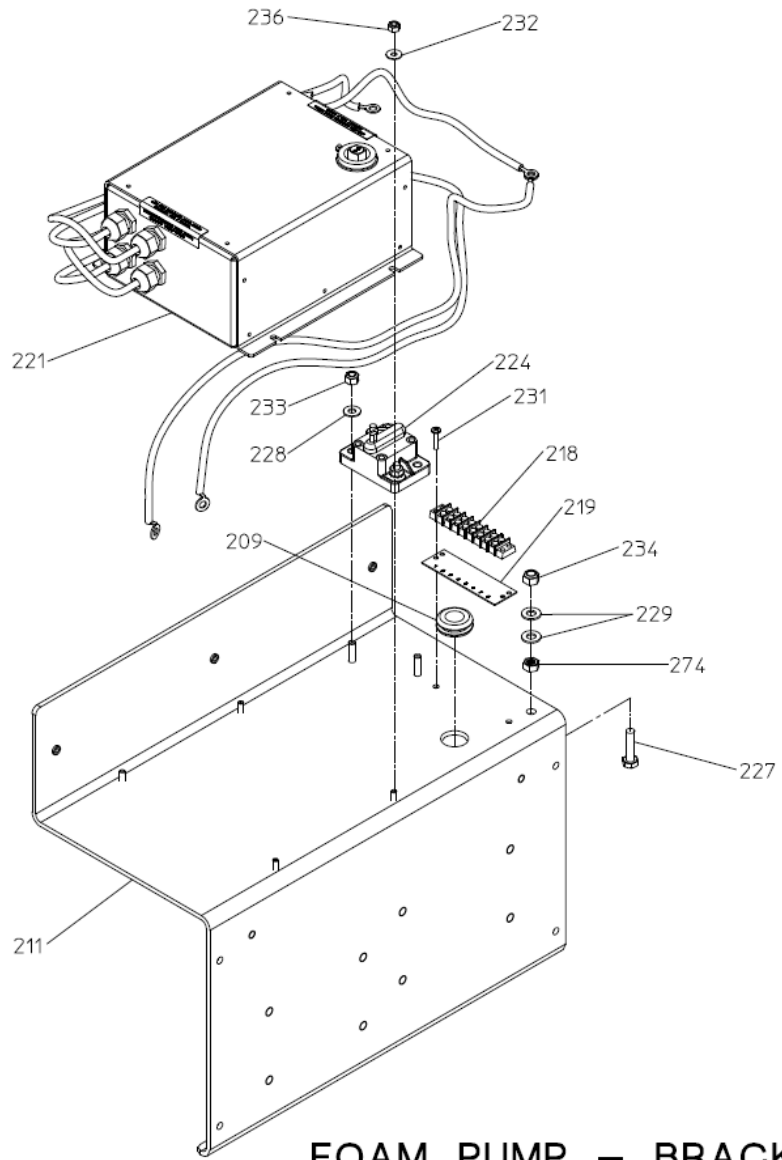

FOAM PUMP – BRACKET & CONTROL MODULE

### Foam Pump – Control Box Wiring

REF NO.	DESCRIPTION
218	8 Position Terminal Block
219	Number Strip

REF NO.	DESCRIPTION
221	Control Box
224	Circuit Breaker



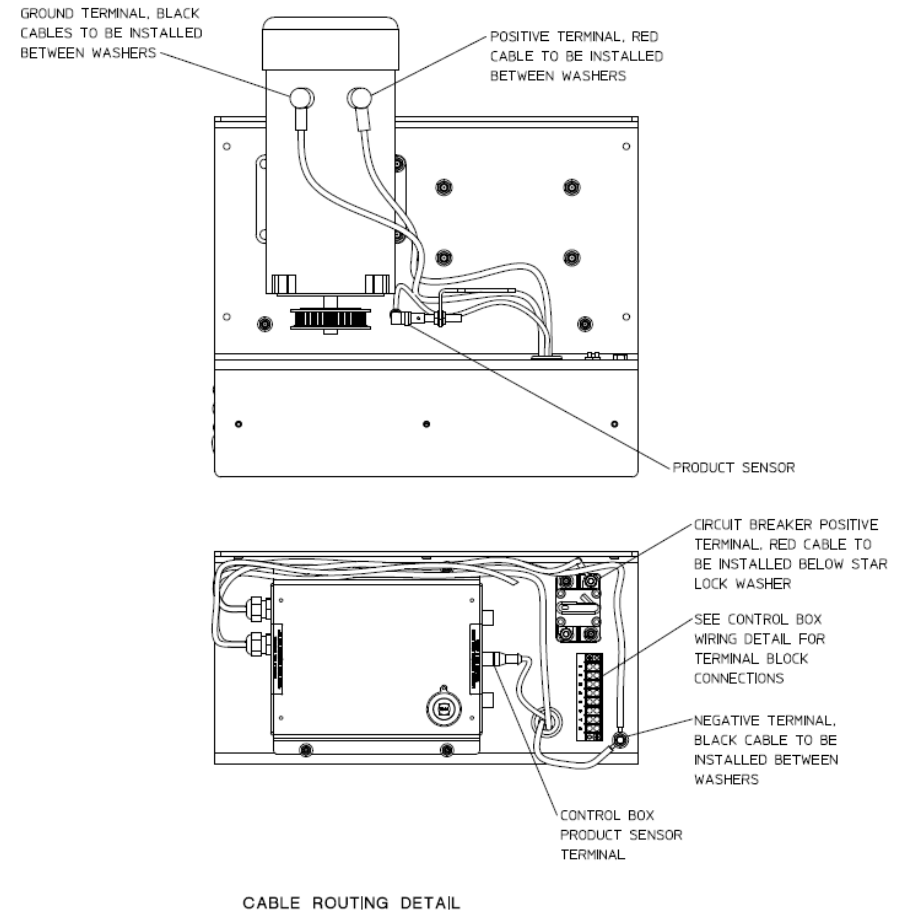
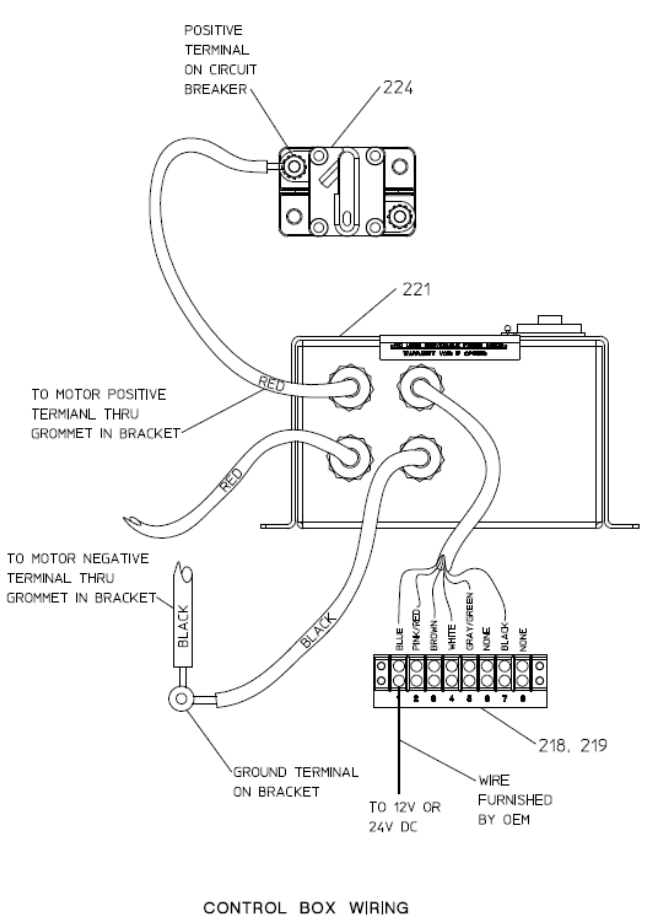

**FOAM PUMP – CONTROL BOX WIRING**

## Foam Manifold - Components

REF NO.	DESCRIPTION
300	Foam Manifold Assembly (Includes 301 thru 310)
301	Foam Manifold
302	Check Valve
303	Victaulic Flange (Includes 308 and 309)
304	Foam Inject Fitting
305	Check Valve, 3/8 in.
306	Conductivity/Temp Probe (Includes Screws and 310)
307	Hex Plug, 3/4 NPT (Brass)
308	Hex Hd Screw, 3/8-16 x 1-1/4 in.
309	O-ring (Victaulic Flange)

REF NO.	DESCRIPTION
310	O-ring, 5/8 x 3/4 in.
350	Clear Manifold Assembly (Includes 351 thru 356)
351	Clear Water Manifold
352	Conductivity Probe (Includes Screws and 355)
353	Flowmeter (Includes 354 and 356)
354	O-ring, 1-1/2 x 1-11/16 in.
355	O-ring, 5/8 x 3/4 in.
356	Socket Head Screw, #10-32 x 3/4 in.

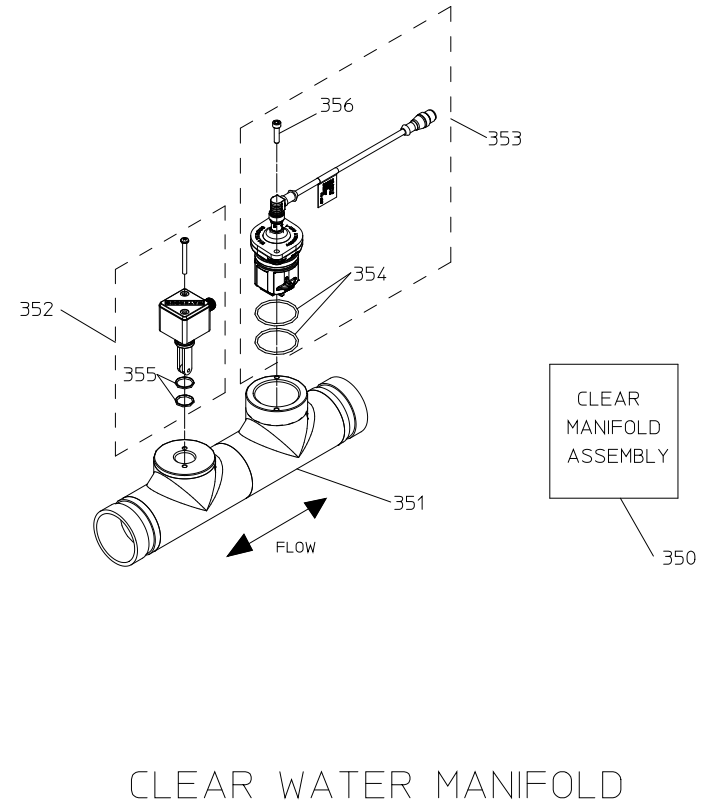
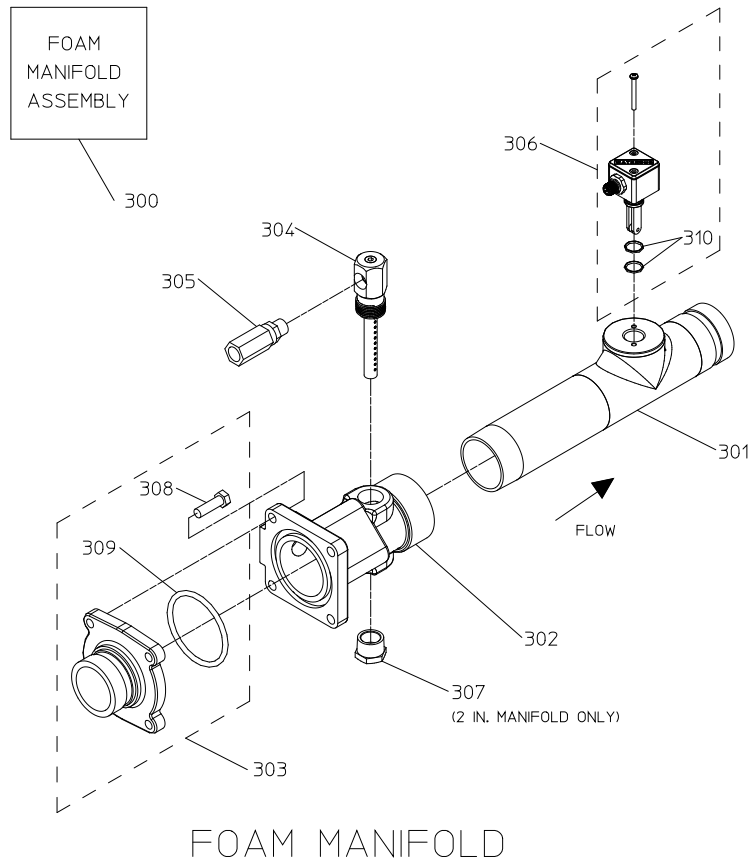

## FOAM MANIFOLD – COMPONENTS

## Foam Manifold - Cables

REF NO.	DESCRIPTION
117	Gray Conductivity (Foam) Cable
118	Flow Meter Cable
120	Black Conductivity (Clear) Cable
221	Control Box
300	Foam Manifold Assembly

REF NO.	DESCRIPTION
306	Conductivity/Temp Probe
350	Clear Manifold Assembly
352	Conductivity Probe
353	Flowmeter

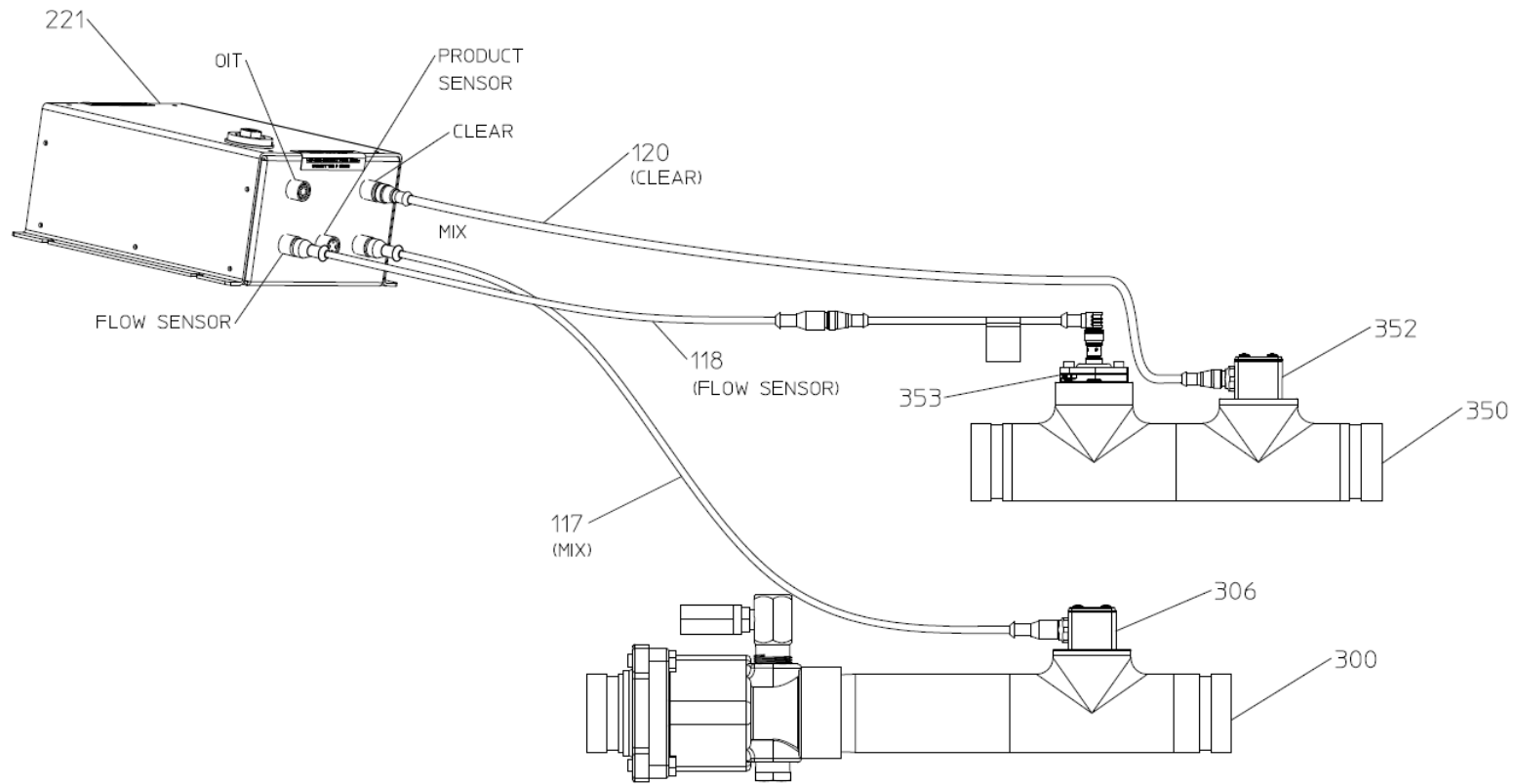

## FOAM MANIFOLD – CABLES

## Panel Components

REF NO.	DESCRIPTION
104	Advantus OIT
105	Instruction Plate
106	Rating Plate
107	Schematic Plate

REF NO.	DESCRIPTION
110	Warning Label
119	OIT Cable, 6 Meters
221	Control Box

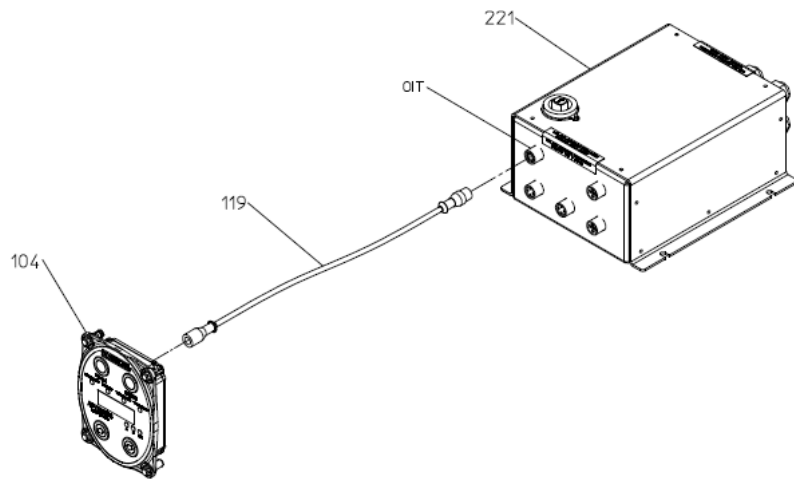

OIT

NOTE: FOR OPTIONAL DUAL OIT. SEE SERVICE PARTS LIST SPL83459

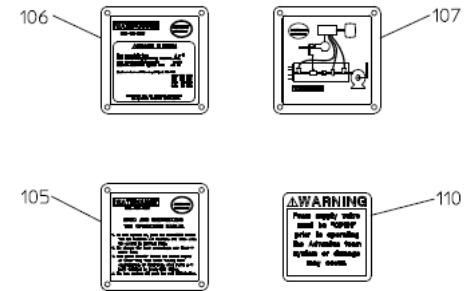

PANEL PLATES

## PANEL COMPONENTS

## Foam Tank

REF NO.	DESCRIPTION
115	Tank Level Switch
121	Tank Level Switch Cable, 4 Meters

REF NO.	DESCRIPTION
218	8 Position Terminal Block
219	Number Strip



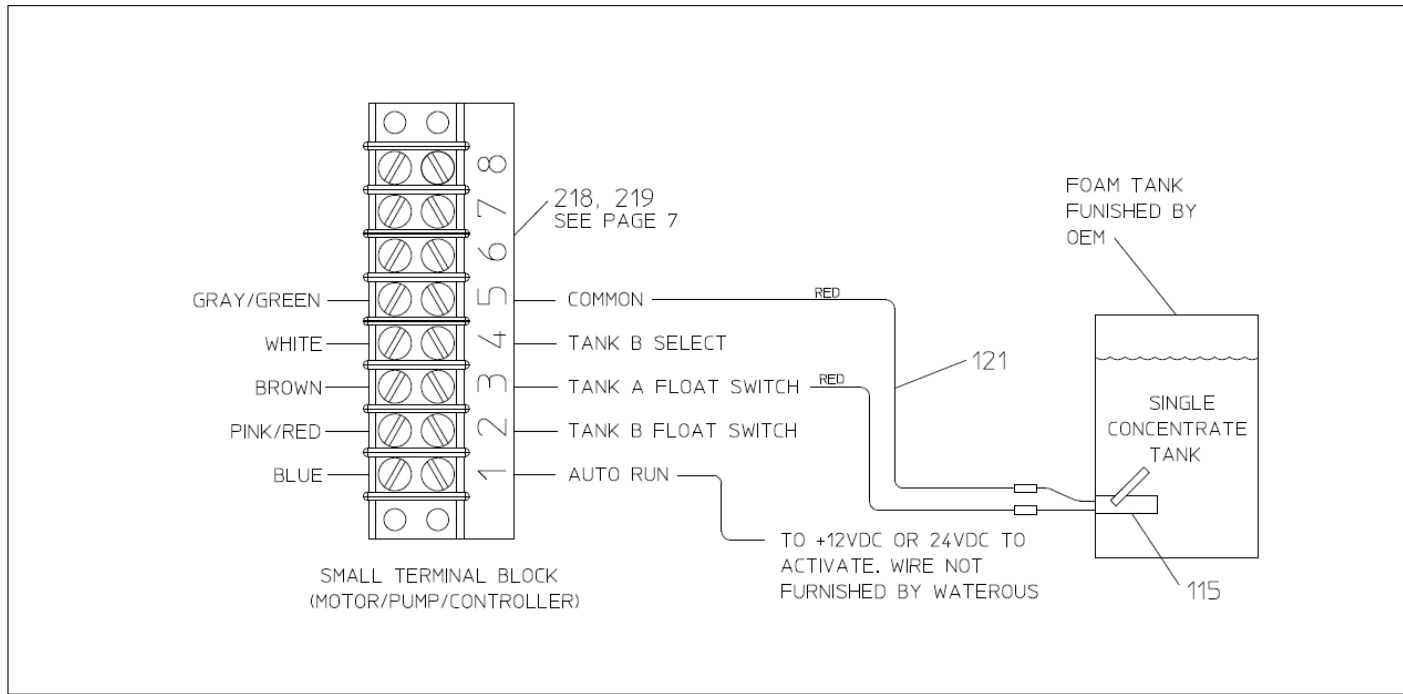

NOTE: FOR OPTIONAL DUAL TANK SELECTOR KIT SEE SERVICE PARTS LIST SPL83440

## FOAM TANK