

Advantus™ Foam System Service Parts List

Models: Advantus 6E, Advantus 6E SSP

Index:

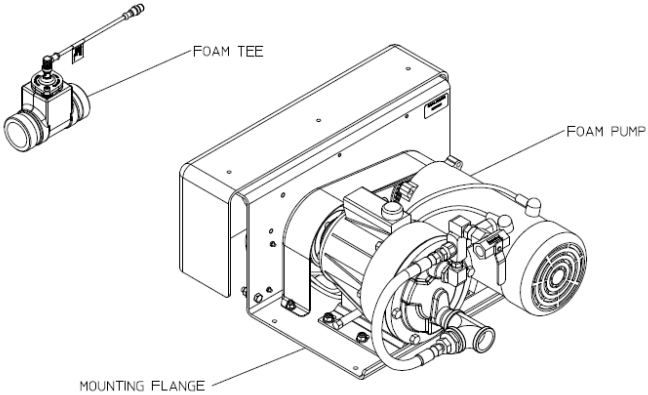

Model Advantus 6E

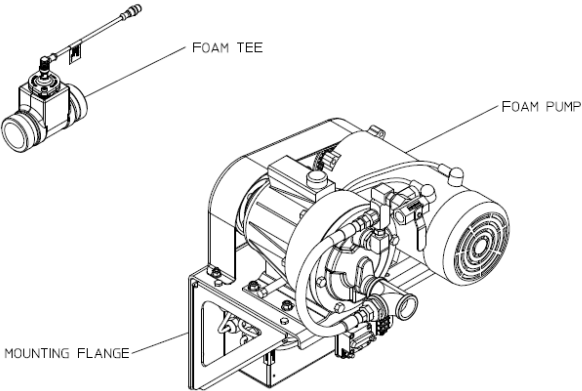

Model Advantus 6E SSP

Component		See Page	
		Advantus 6E	Advantus 6E SSP
Foam Pump	Complete Unit	2, 3	2, 3
	Pump and Motor	4, 5	6, 7
	Bracket and Control Module	8, 9	
	Control Box Wiring	10, 11	
Foam Tee Components and Cable		12, 13	
Panel Components		14, 15	
Foam Tank		16, 17	
Master Waterway Check Valve		See Service Parts List SPL83380	
Foam Supply and Inject/By-Pass Hose Kits		See Service Parts List SPL83430	
Dual Foam Tank Selector Kit		See Service Parts List SPL83440	
Dual OIT Kit		See Service Parts List SPL83459	

Foam Pump – Complete Unit

REF NO.	DESCRIPTION
100	Foam Pump Cover
101	Cover Label
102	Pan Head Screw, No. 10-32 x 1/2 in.

REF NO.	DESCRIPTION
103	Plain Washer, No. 10
200	Foam Pump Ass'y (Includes 201 thru 273)

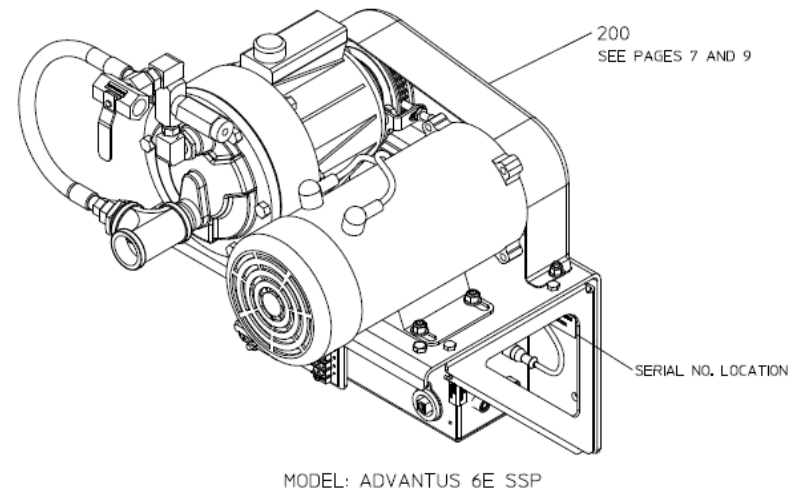
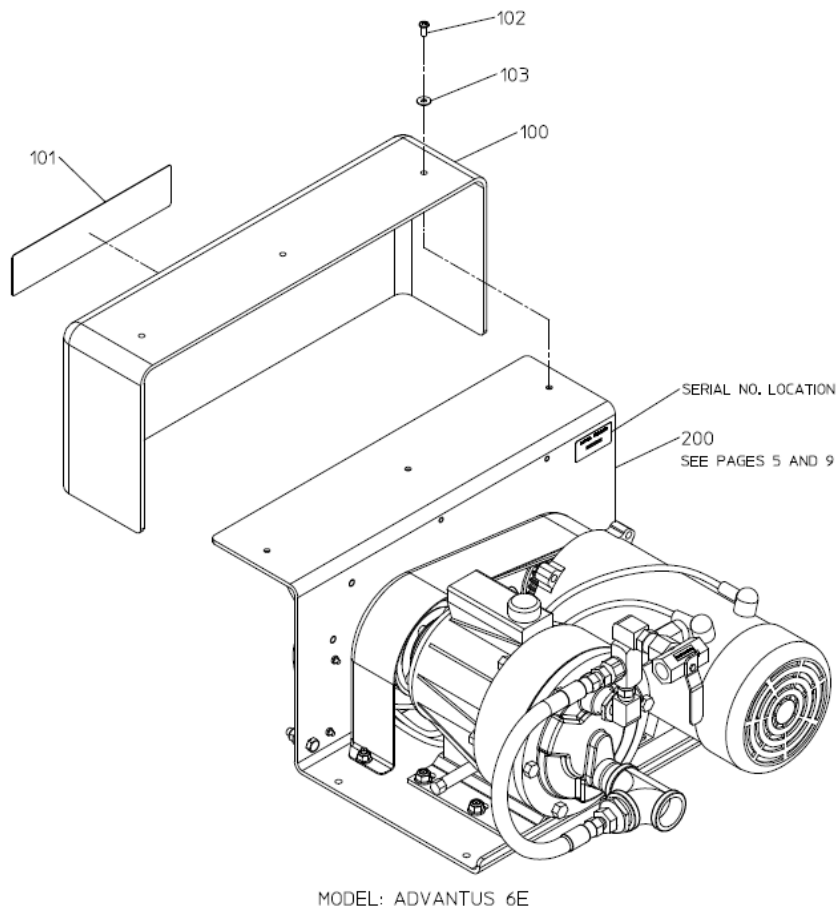

FOAM PUMP – COMPLETE UNIT

**Foam Pump – Pump and Motor
Model Advantus 6E**

REF NO.	DESCRIPTION
112	Wye Strainer, 1 in. (Includes 113 and 123)
113	Strainer Screen
123	Strainer Gasket
126	Check Valve, 3/8 in.
201	Straight Adapter, 3/8 MNPT x 3/8 MNPT
202	Straight Adapter, 6 MJIC x ½ MNPT
203	Street Elbow, 90 Deg., 3/8 NPT
205	Straight Adapter, 6 MJIC x 3/8 MNPT
206	Straight Adapter, 3/8 MNPT x ½ MNPT
207	Black Boot
208	Red Boot
210	Bypass Hose
215	3 Way Ball Valve
216	Pressure Regulator
217	Product Sensor
220	Electric Motor
222	Product Sensor Cable
223	Foam Pump (Includes 237)
228	Plain Washer, ¼ in.

REF NO.	DESCRIPTION
229	Plain Washer, 5/16 in.
233	Nylok Hex Nut, ¼-20
234	Nylok Hex Nut, 5/16-18
237	Vented Oil Fill Cap
238	Belt Guard
262	Reducing Bushing, ¾ MNPT x 3/8 FNPT
263	Reducing Bushing, 1 MNPT x ½ FNPT
264	Close Pipe Nipple (Brass), 1 in. NPT
265	Tee, 1 FNPT x 1 FNPT x 1 FNPT
268	Belt
269	Speed Sensor Bracket
270	Pump Sprocket
271	Motor Sprocket
272	Taperlock Bushing, 7/8 in.
273	Taperlock Bushing, 5/8 in.
275	Hex Head Screw, M10-1.75 x 20mm
276	Lock Washer, 10mm
277	Foam Pump Rebuild Kit

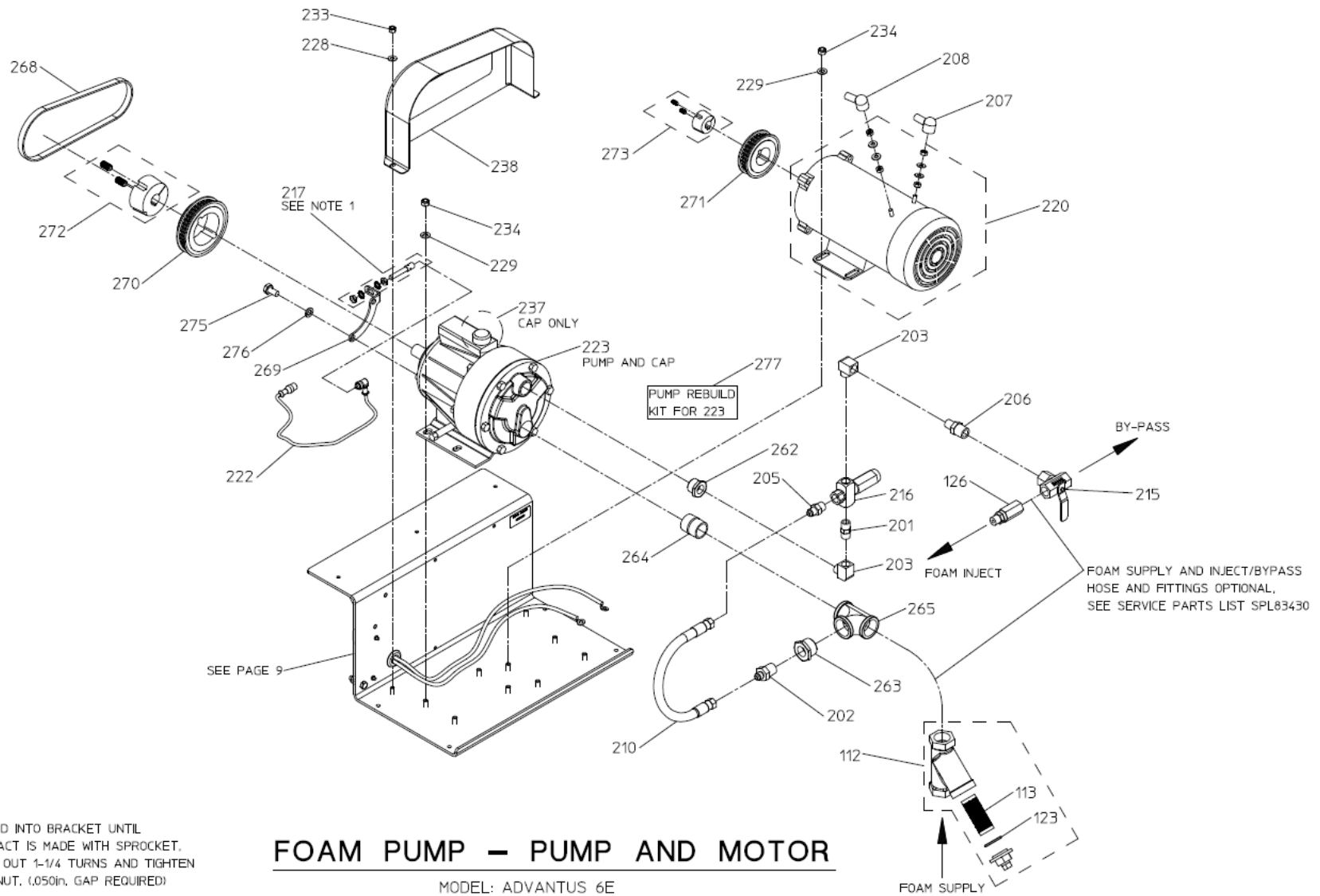

**Foam Pump – Pump and Motor
Model Advantus 6E SSP**

REF NO.	DESCRIPTION
101	Waterous Label
112	Wye Strainer, 1 in. (Includes 113 and 123)
113	Strainer Screen
123	Strainer Gasket
126	Check Valve, 3/8 in.
129	Foam Inject Fitting
201	Straight Adapter, 3/8 MNPT x 3/8 MNPT
202	Straight Adapter, 6 MJIC x ½ MNPT
203	Street Elbow, 90 Deg., 3/8 NPT
205	Straight Adapter, 6 MJIC x 3/8 MNPT
206	Straight Adapter, 3/8 MNPT x ½ MNPT
207	Black Boot
208	Red Boot
210	Bypass Hose
215	3 Way Ball Valve
216	Pressure Regulator
217	Product Sensor
220	Electric Motor
222	Product Sensor Cable
223	Foam Pump (Includes 237)
228	Plain Washer, ¼ in.

REF NO.	DESCRIPTION
229	Plain Washer, 5/16 in.
233	Nylok Hex Nut, ¼-20
234	Nylok Hex Nut, 5/16-18
237	Vented Oil Fill Cap
238	Belt Guard
262	Reducing Bushing, ¾ MNPT x 3/8 FNPT
263	Reducing Bushing, 1 MNPT x ½ FNPT
264	Close Pipe Nipple (Brass), 1 in. NPT
265	Tee, 1 FNPT x 1 FNPT x 1 FNPT
268	Belt
269	Speed Sensor Bracket
270	Pump Sprocket
271	Motor Sprocket
272	Taperlock Bushing, 7/8 in.
273	Taperlock Bushing, 5/8 in.
275	Hex Head Screw, M10-1.75 x 20mm
276	Lock Washer, 10mm
277	Foam Pump Rebuild Kit

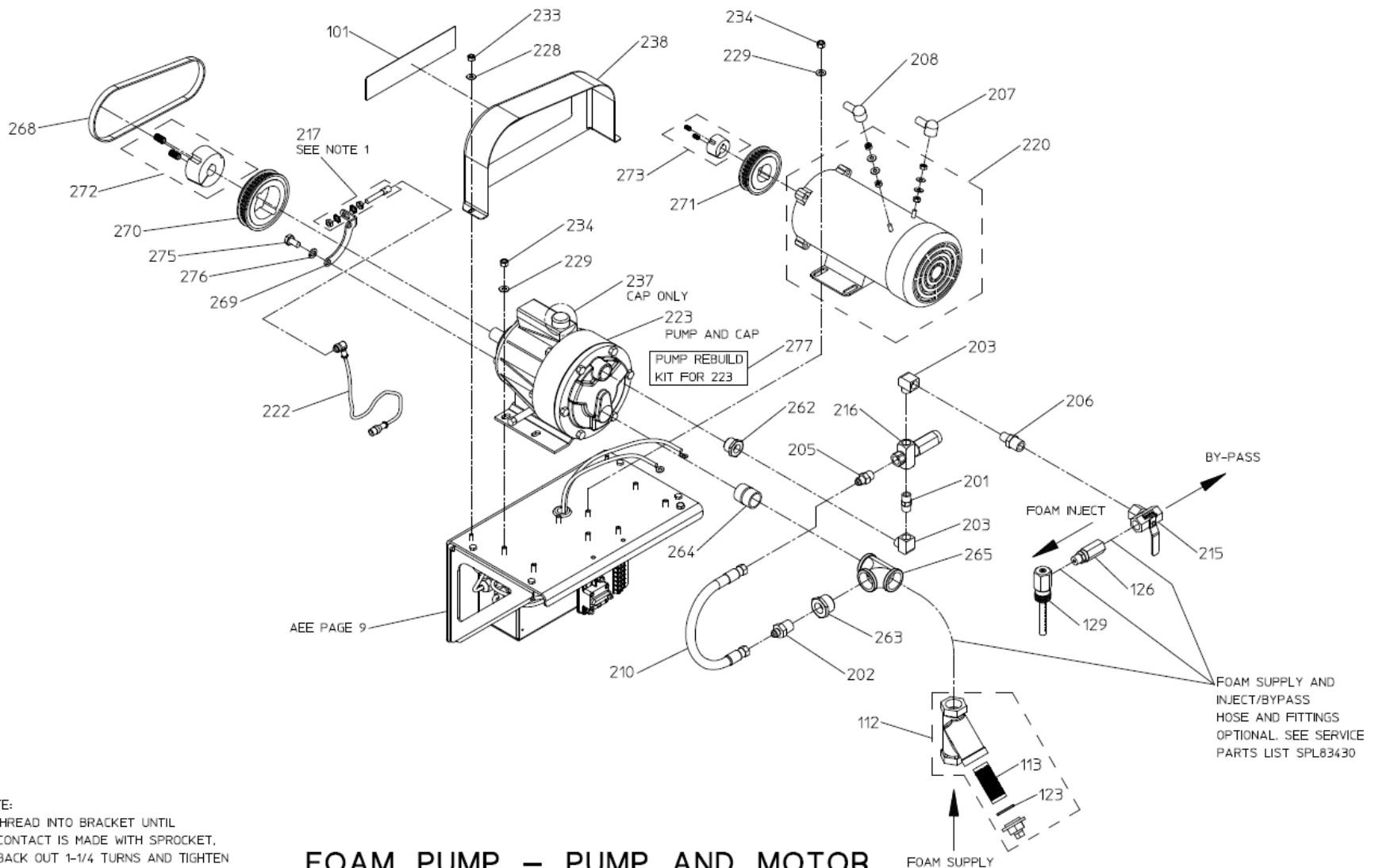

NOTE:
 1. THREAD INTO BRACKET UNTIL CONTACT IS MADE WITH SPROCKET. BACK OUT 1-1/4 TURNS AND TIGHTEN LOCKNUT. (.050in. GAP REQUIRED)

FOAM PUMP – PUMP AND MOTOR
 MODEL: ADVANTUS 6E SSP

Foam Pump – Bracket and Control Module

REF NO.	DESCRIPTION
209	Grommet
211	Z Bracket
218	8 Position Terminal Block
219	Number Strip
221	Control Box
224	Circuit Breaker
227	Hex Head Screw, 5/16-18 x 1-1/4 in.
228	Plain Washer, 1/4 in.
229	Plain Washer, 5/16 in.
231	Screw-Pan Head, No. 8-32 x 3/4 in.

REF NO.	DESCRIPTION
232	Plain Washer, No. 10
233	Nylok Hex Nut, 1/4-20
234	Nylok Hex Nut, 5/16-18
236	Nylok Hex Nut, No. 10-32
241	Hex Hd Screw, 1/4-20 x 1 in.
242	Nylok Hex Nut, No. 8-32
266	Gusset
267	Circuit Breaker Bracket
274	Hex Nut, 5/16-18

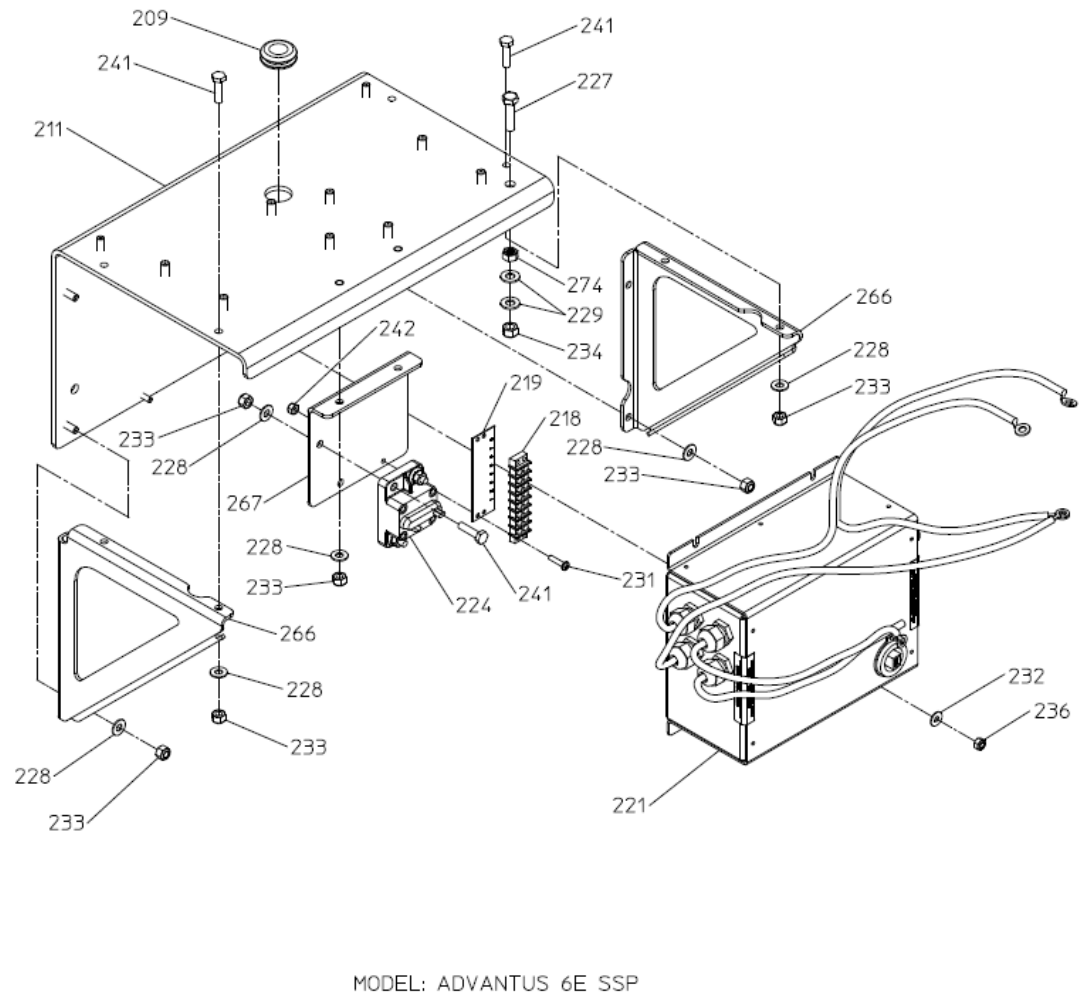
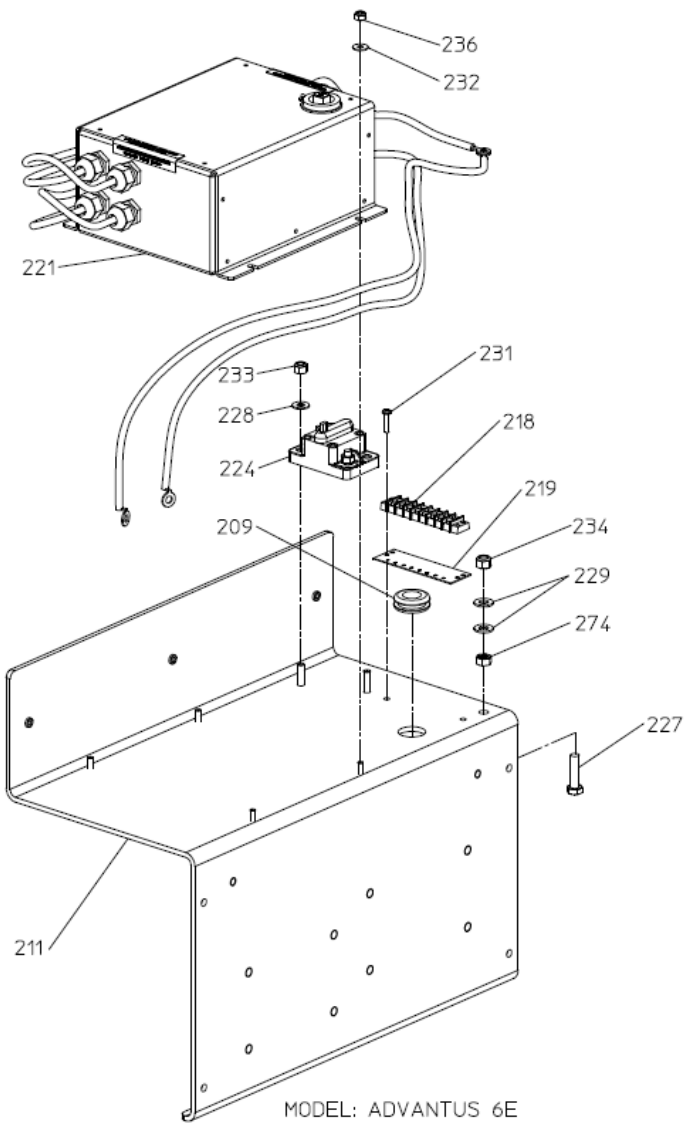

FOAM PUMP – BRACKET & CONTROL MODULE

Foam Pump – Control Box Wiring

REF NO.	DESCRIPTION
218	8 Position Terminal Block
219	Number Strip

REF NO.	DESCRIPTION
221	Control Box
224	Circuit Breaker

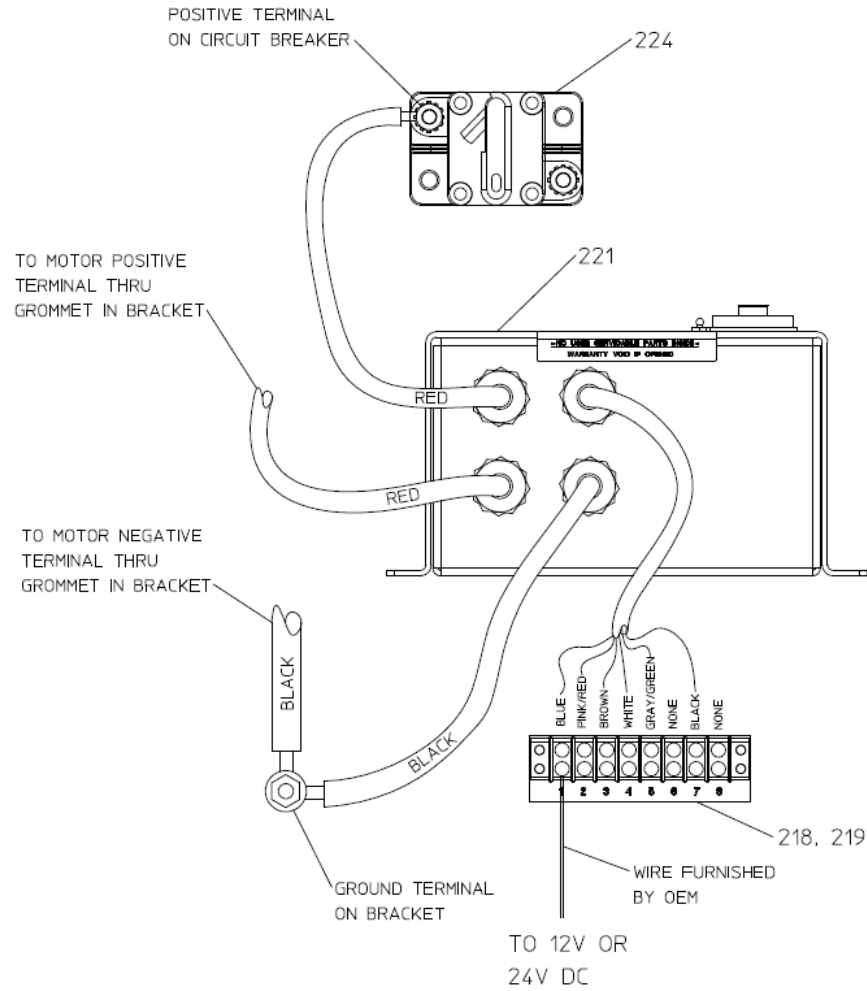

FOAM PUMP – CONTROL BOX WIRING

Foam Tee – Components and Cable

REF NO.	DESCRIPTION
118	Flowmeter Cable, 3 Meter
124	Port Plug
221	Control Box
300	FNPT Tee x Victaulic

REF NO.	DESCRIPTION
301	Flowmeter (Includes 302 and 303)
302	O-ring, 1-1/2 x 1-11/16 in.
303	Socket Hd Screw, No. 10-32 x 3/4 in.

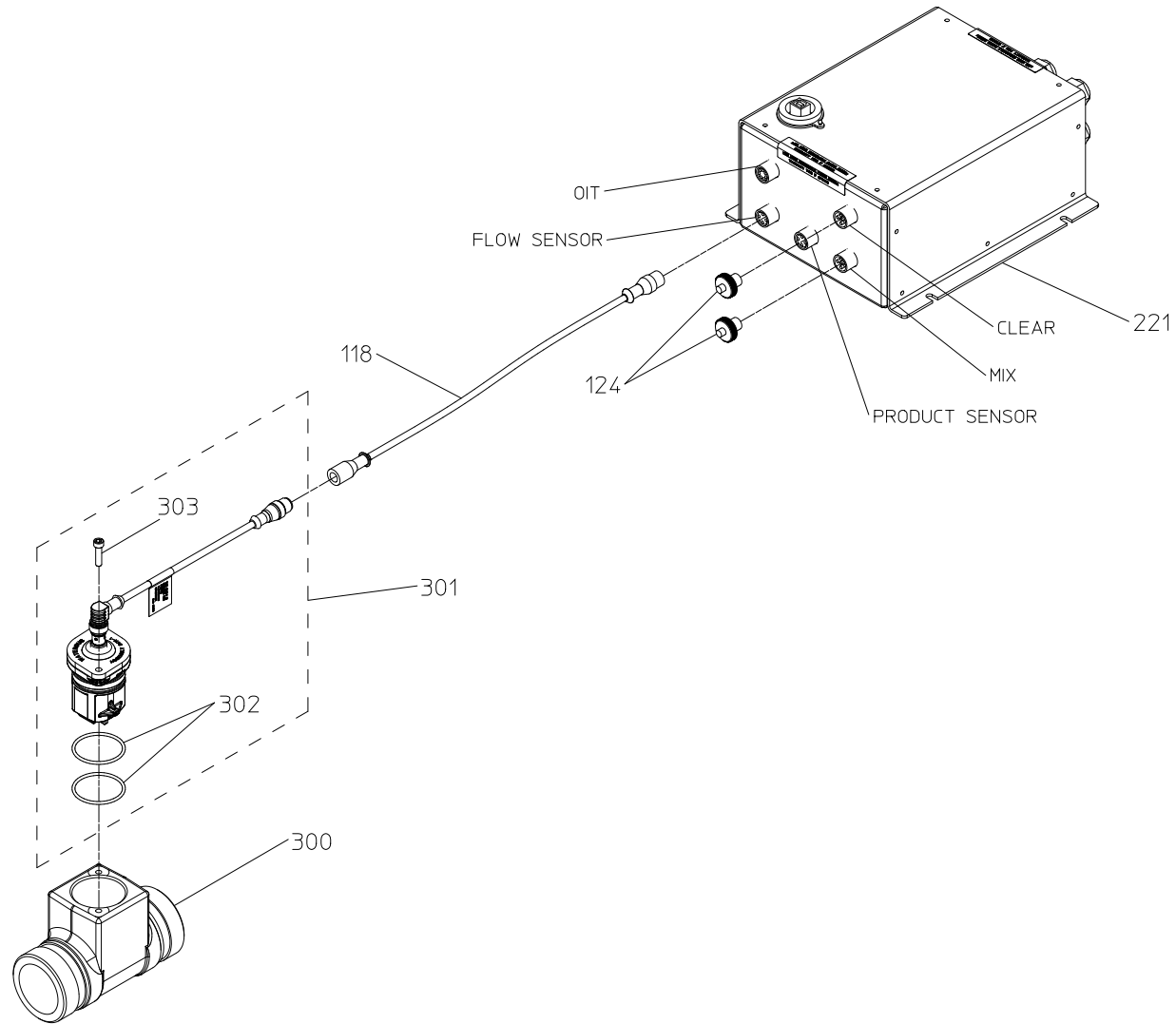

FOAM TEE – COMPONENTS AND CABLE

Panel Components

REF NO.	DESCRIPTION
104	Advantus OIT
105	Instruction Plate
106	Rating Plate
107	Schematic Plate

REF NO.	DESCRIPTION
110	Advantus Warning Label
119	6 Meter Length Advantus OIT Cable
221	Control Box

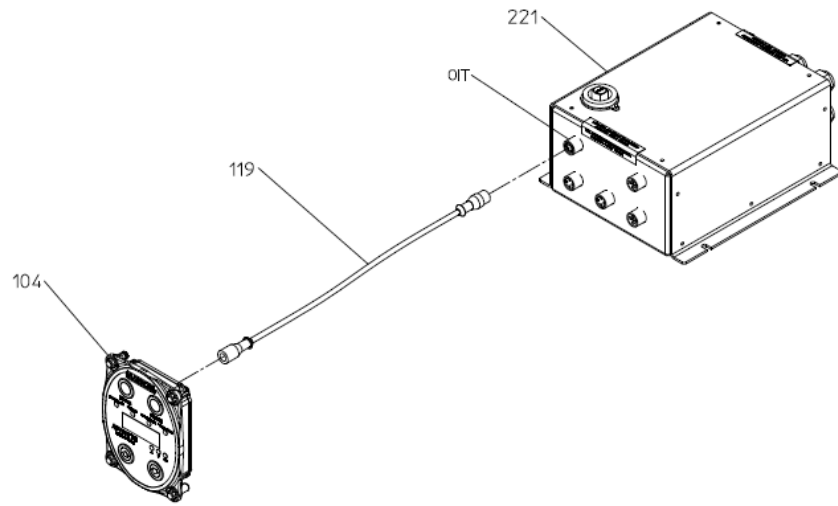

OIT

NOTE: FOR OPTIONAL DUAL OIT, SEE SERVICE PARTS LIST SPL83459

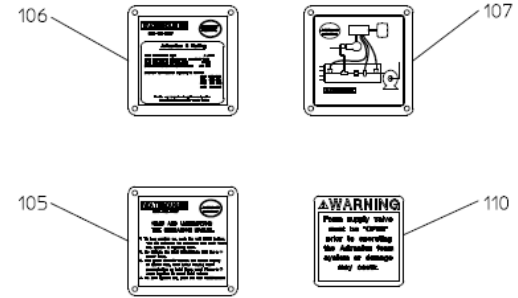

PANEL PLATES

PANEL COMPONENTS

Foam Tank

REF NO.	DESCRIPTION
115	Tank Level Switch
121	4 Meter Length Tank Level Switch Cable

REF NO.	DESCRIPTION
218	8 Position Terminal Block
219	Number Strip

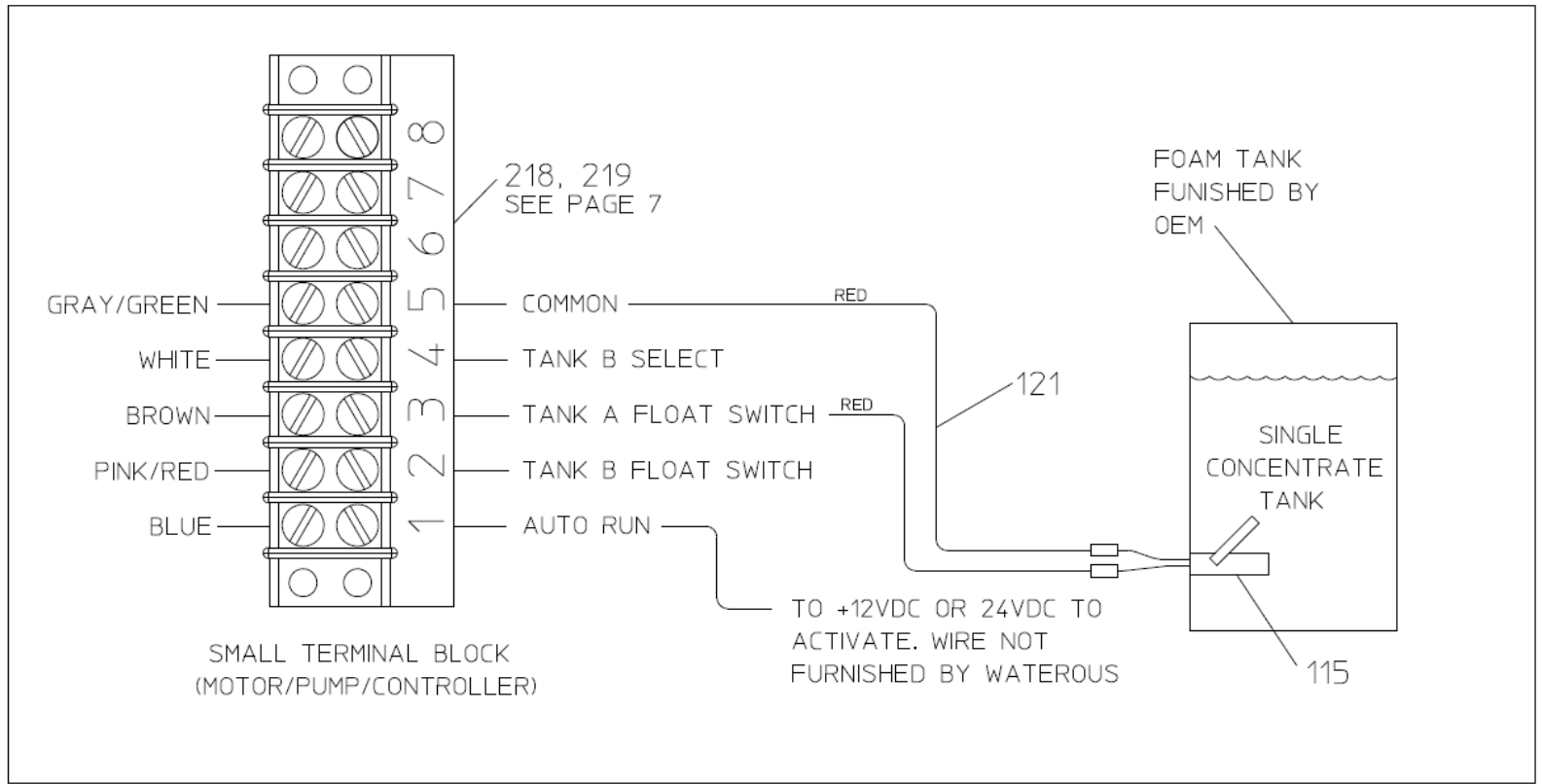

NOTE: FOR OPTIONAL DUAL TANK SELECTOR KIT SEE SERVICE PARTS LIST SPL83440

FOAM TANK