

## Aquis™ Foam System Service Parts List Models: Aquis 2.5, Aquis 2.5 SSP

### Index:

Component		See Pages
Foam Pump	Complete Unit	2, 3
	Pump and Motor	4, 5
	Bracket and Control Module	6, 7
	Control Box Wiring	8, 9
Foam Tee	Components	10, 11
	Cable	12, 13
Panel Components		14, 15
Foam Tank		16, 17
Master Waterway Check Valve		See Service Parts List SPL83380
Foam Supply and Inject/By-Pass Hose Kits		See Service Parts List SPL83430
Dual OIT Kit		See Service Parts List SPL83459

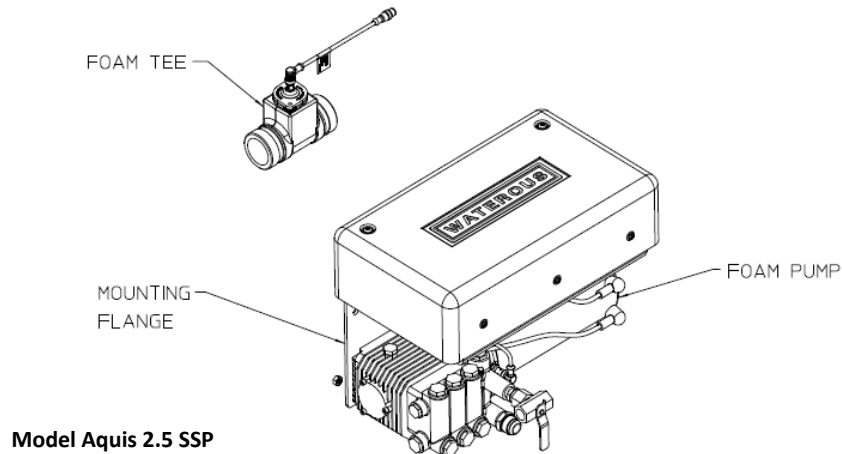
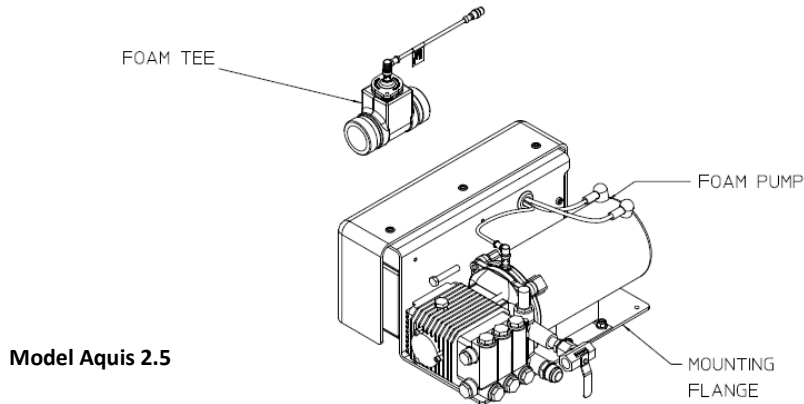

## Foam Pump – Complete Unit

REF NO.	DESCRIPTION
100	Foam Pump Cover
101	Waterous Label
102	Pan Head Screw, No. 10-32 x 1/2 in.
103	Plain Washer, No. 10

REF NO.	DESCRIPTION
127	Pan Hd Screw, ¼-20 x ¾ in.
128	Plain Washer, ¼ in.
200	Foam Pump Ass'y (Includes 201 thru 235)

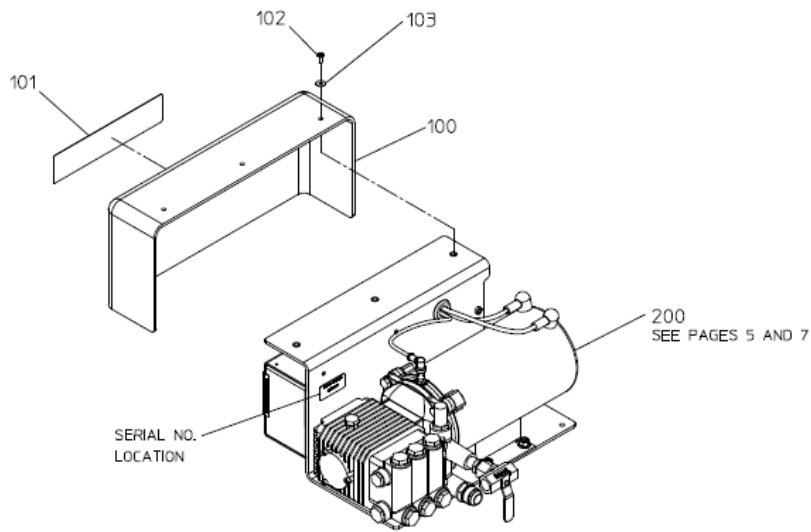

MODEL AQUIS 2.5

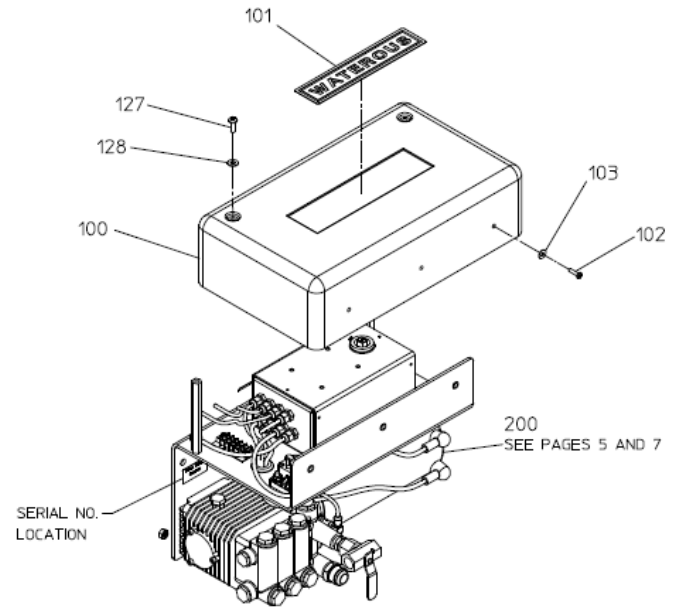

MODEL AQUIS 2.5 SSP

FOAM PUMP – COMPLETE UNIT

## Foam Pump – Pump and Motor

REF NO.	DESCRIPTION
105	Wye Strainer, 3/4 in. (Includes 106 and 107)
106	Strainer Screen
107	Strainer Gasket
108	Check Valve, 3/8 in.
201	Straight Adapter, 12 MJIC x ½ MNPT
202	Reducing Bushing, 3/8 MNPT x ½ FNPT
207	Black Boot
208	Red Boot
213	Pump Spacer
214	Sensor Wheel
215	3 Way Ball Valve

REF NO.	DESCRIPTION
217	Product Sensor
220	Electric Motor
223	Foam Pump (Includes 236)
226	Hex Hd Screw, 3/8-16 x 2 in.
230	Lock Washer, 3/8 in.
236	Oil Fill Dip Stick

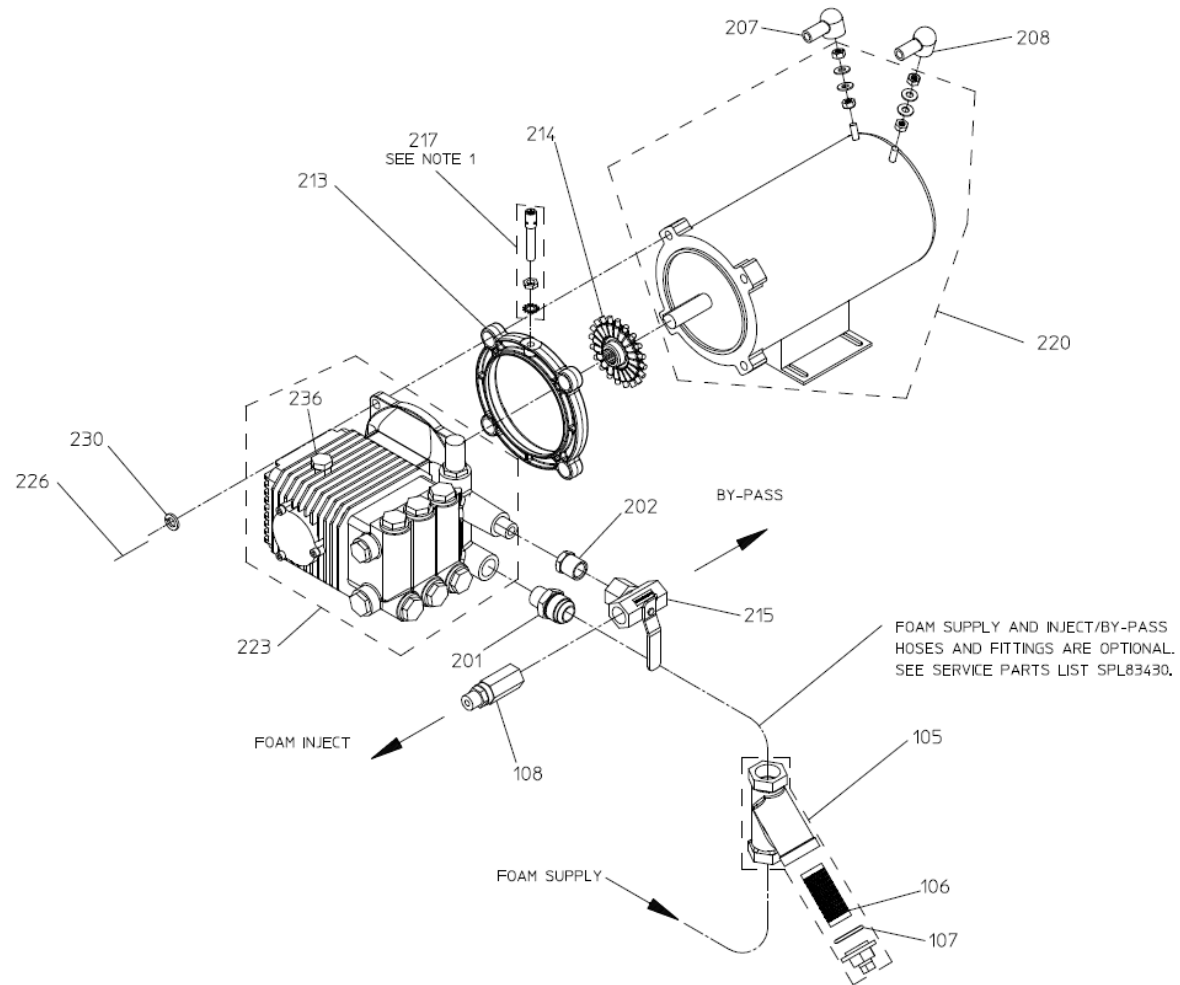

**NOTE:**

1. DISCARD EXTRA NUT AND STAR LOCK WASHER. THREAD INTO PUMP SPACER UNTIL CONTACT IS MADE WITH SENSOR WHEEL. BACK OUT 1-1/4 TURNS AND TIGHTEN LOCKNUT. (.050in. GAP REQUIRED)

## FOAM PUMP – PUMP AND MOTOR

## Foam Pump – Bracket and Control Module

REF NO.	DESCRIPTION
207	Black Boot
208	Red Boot
209	Grommet
211	Z Bracket
212	Standoff, ¼-20 x 5 in.
218	5 Position Terminal Block
219	Number Strip
221	Control Box Subassembly
224	Circuit Breaker, 50A
225	Hex Head Screw, ¼-20 x 3/4 in.

REF NO.	DESCRIPTION
227	Hex Head Screw, 5/16-18 x 1-1/4 in.
228	Plain Washer, ¼ in.
229	Plain Washer, 5/16 in.
231	Screw-Pan Head, No. 8-32 x ¾ in.
232	Plain Washer, No. 10
233	Nylok Hex Nut, ¼-20
234	Nylok Hex Nut, 5/16-18
235	Nylok Hex Nut, No. 10-32
237	Hex Nut, 5/16-18

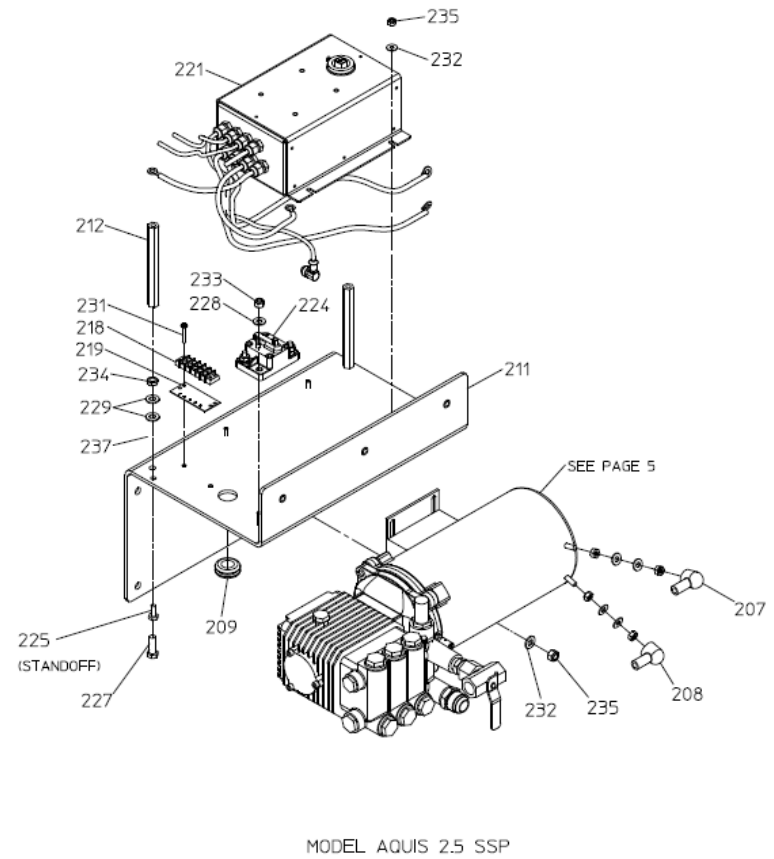
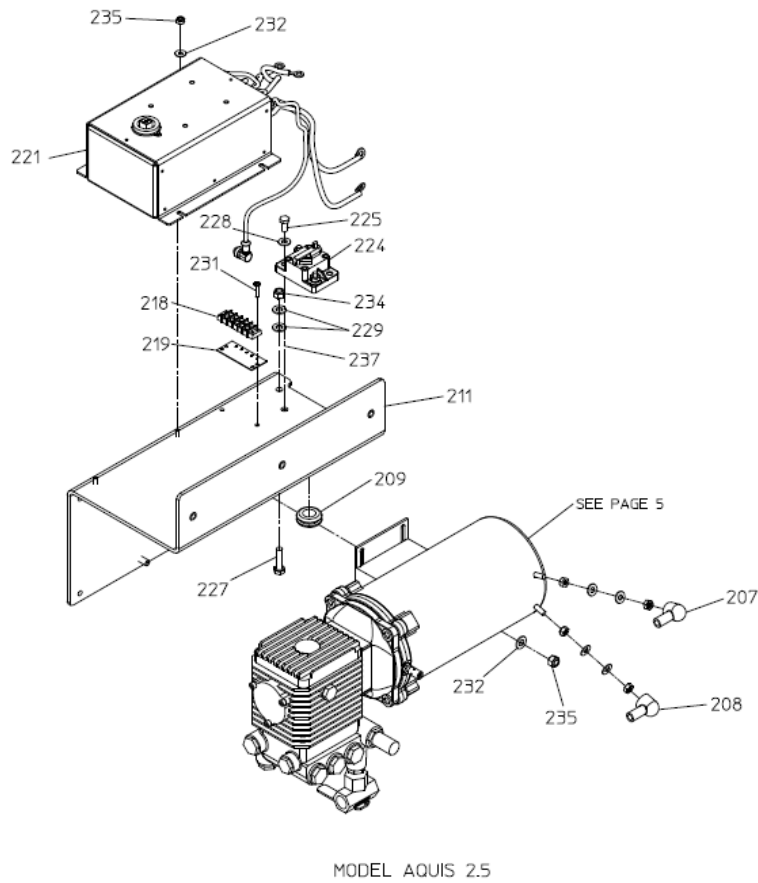

## FOAM PUMP – BRACKET & CONTROL MODULE

## Foam Pump – Control Box Wiring

REF NO.	DESCRIPTION
218	5 Position Terminal Block
219	Number Strip

REF NO.	DESCRIPTION
221	Control Box
224	Circuit Breaker



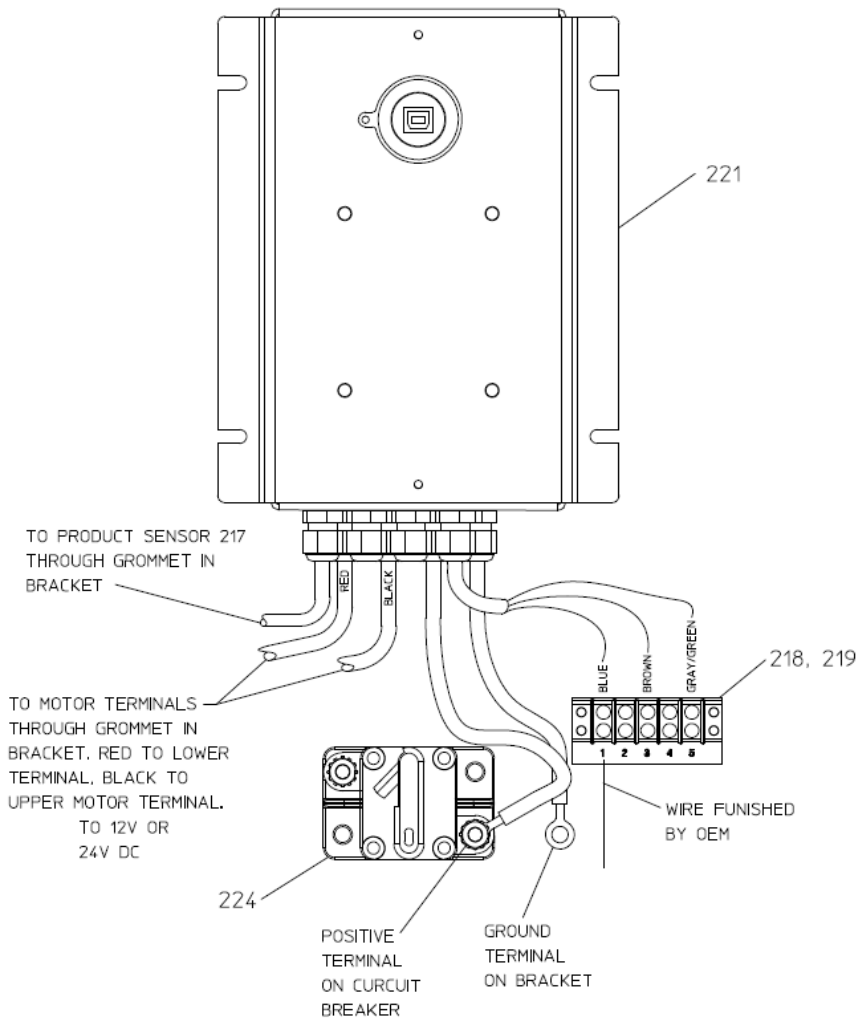

## FOAM PUMP – CONTROL BOX WIRING

## Foam Tee – Components

REF NO.	DESCRIPTION
300	FNPT Tee x Victaulic
301	Flowmeter (Includes 302 and 303)

REF NO.	DESCRIPTION
302	O-ring, 1-1/2 x 1-11/16 in.
303	Socket Hd Screw, No. 10-24 x 3/4 in.

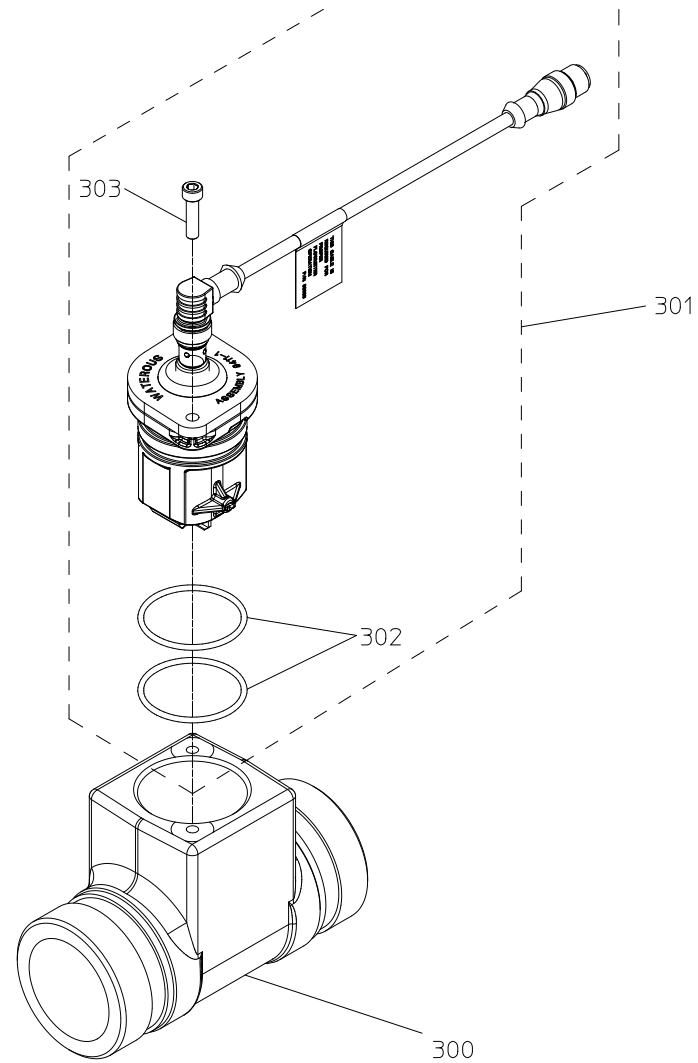

## FOAM TEE – COMPONENTS

## Foam Tee - Cable

REF NO.	DESCRIPTION
115	Flow Sensor Extension Cable, 3 Meter
221	Control Box

REF NO.	DESCRIPTION
300	FNPT Tee x Victaulic
301	Flowmeter

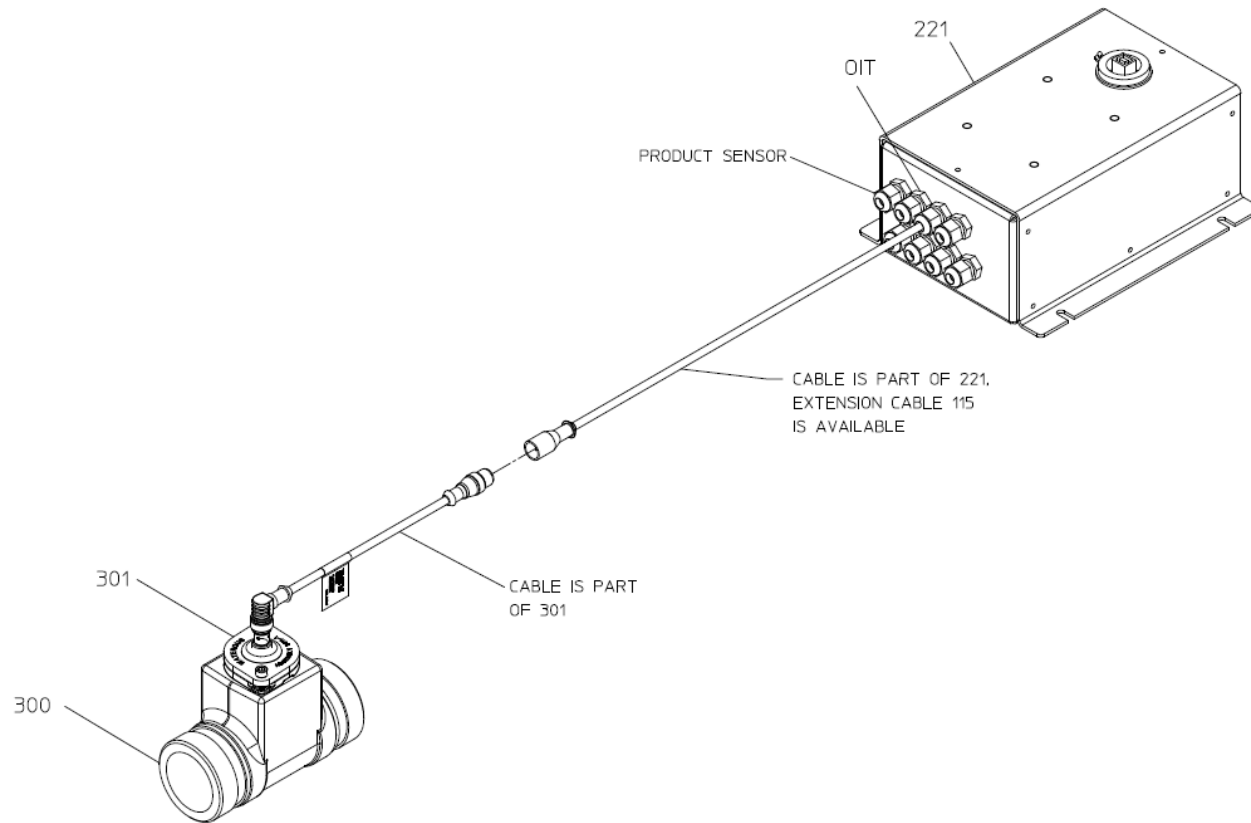

## FOAM TEE – CABLE

## Panel Components - OIT

REF NO.	DESCRIPTION
104	Aquis 2.5 OIT
109	Instruction Plate
110	Schematic Plate
111	Aquis 2.5 Rating Plate

REF NO.	DESCRIPTION
116	OIT Extension Cable, 3 or 6 Meter
117	V-MUX Adapter Cable
221	Control Box Subassembly

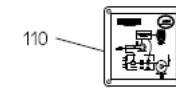
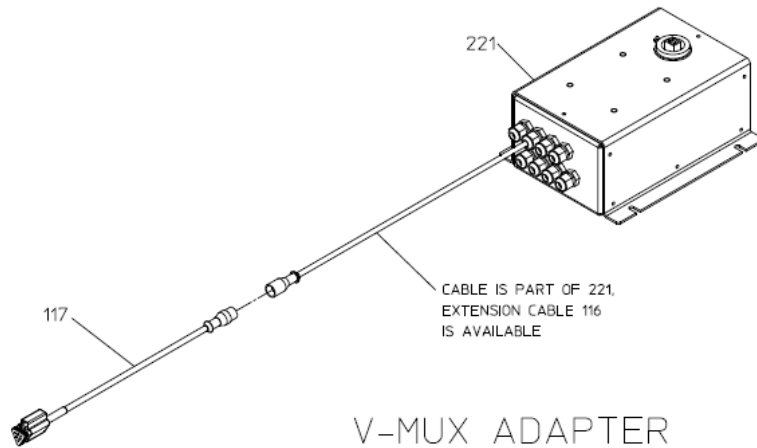
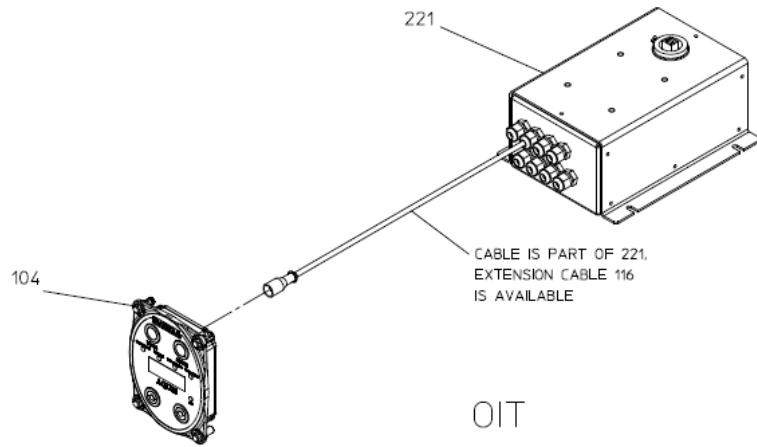

PANEL PLATES

**PANEL COMPONENTS**

NOTE: FOR OPTIONAL DUAL OIT KIT, SEE SERVICE PARTS LIST SPL83459

## Foam Tank

REF NO.	DESCRIPTION
112	Tank Level Switch
114	4 Meter Length Tank Level Switch Cable

REF NO.	DESCRIPTION
218	5 Position Terminal Block
219	Number Strip



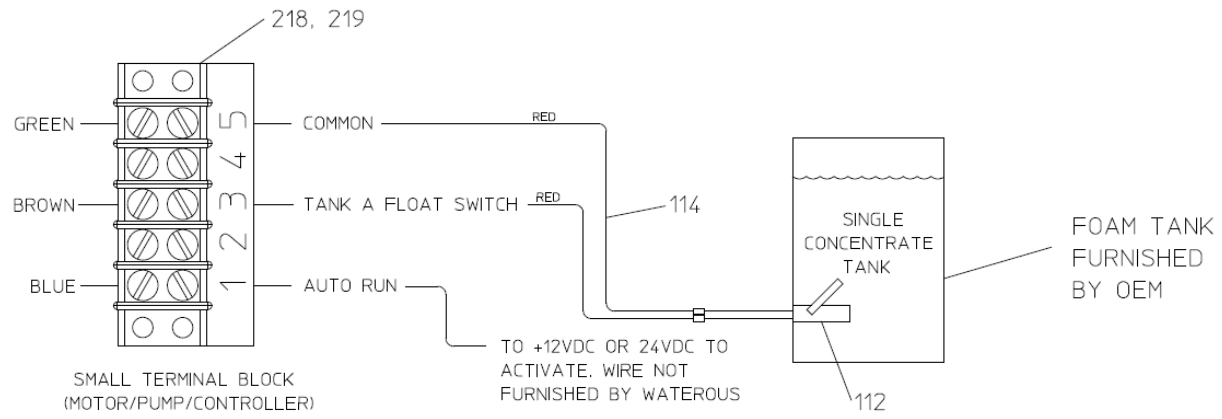

## FOAM TANK