

SPECIFICATIONS – ACCESSORIES: DRAIN VALVES

Drain Your Fire Pump Using a Single Control

The Waterous drain valve provides a convenient means of draining a fire pump and related equipment after each operation. Its design permits simultaneous draining of at least eight lines. It consists essentially of a stainless steel sliding plunger in a bronze body.

Two valves are offered. The panel mounted valve and the remote mounted valve.

Panel Mounted Drain Valve

The panel mounted valve is horizontally mounted on the pump operator's panel.

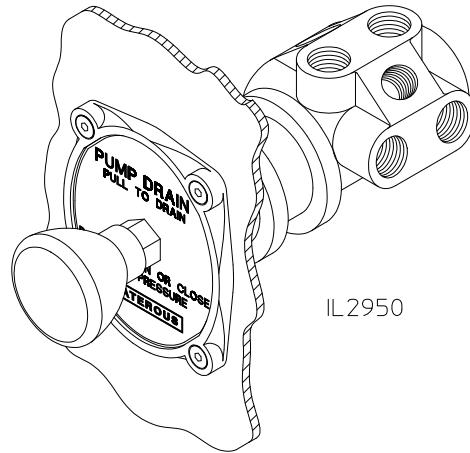

Remote Mounted Drain Valve

The remote mounted valve is vertically mounted on the pump transmission, or at a remote location, and is operated by a flexible cable from the pump control panel.

This valve is designed so that discharge pressure will act on the plunger to keep the valve closed when the valve has been manually closed. The correct installation procedure and the correct drain connections must be made for the valve to function properly.

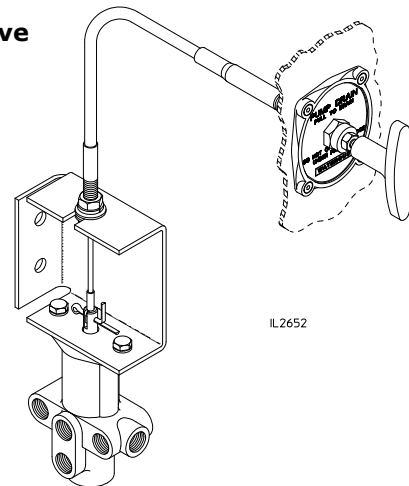

Industry Leading Sales and Support

When you purchase equipment, not only do you get quality products, you get quality service. Our expert service technicians are the best in the business and they are always happy to answer any service questions you might have.

Sales/Applications Assistance
Phone: 651-450-5234 (Press 3)
pumpsales@waterousco.com

Service Assistance
Phone: 651-450-5200
Fax: 800-488-1228
service@waterousco.com

