



Document Number	Issue Date	Rev. Date
SPL80331	07/75	11/15/11

TML Series P.T.O. Service Parts List

Index:

Feature		Model		See	
				Detail	Pages
Case and Driveline		All		-	2-5
Output Shaft	Single Output	TML-1CA	TML-2CA	A	6-7
		TML-1CB	TML-2CB	B	
		TML-1CF	SAE Class B	C	
		TML-2CF	SAE Class C	D	
		TML-1DA	TML-2DA	C	
		TML-1DB	TML-2DB		
		TML-1EA	TML-2EA	D	
	-	TML-2EB			
	Dual Output	TML-1CA2CA	-	E	8-9
		TML-1CA2CB	TML-1CB2CA	F	
		TML-1CA2CF	SAE Class B	G	
			SAE Class C	H	
		TML-1CA2DA	TML-1DA2CA	G	
		TML-1CA2DB	TML-1DB2CA		
		TML-1CA2DF	TML-1CF2CA		
		TML-1CA2EA	TML-1EA2CA	H	
		TML-1CA2EB	-		
		TML-1CF2CA	SAE Class B	G	
			SAE Class C	H	
TML-1DD2DD		-	J	10-11	
TML-1EA2DC	-	K			
Optional	Driveline Input Shaft	Tachometer	All	-	12-13
	Output Shaft	Governor Drive	All	-	
	Driveline Output Shaft	Speedometer	All	-	14-15
		Parking Brake Provision	All	-	

Waterous Company 125 Hardman Avenue South, South St. Paul, Minnesota 55075 USA (651) 450-5000
When ordering repair parts, please supply pump serial number.

Case and Driveline

REF. NO.	DESCRIPTION
T1	Shift Arm Spring
T2	Drive Gear
T3	Gear Case Assembly
T5	Serial Plate
T8	Drive Shaft Spacer
T9	Coupling Shaft Bearing Spacer
T11	Oil Seal Sleeve
T13	Shift Arm Spring Housing
T15	Adjusting Screw
T16	Adjusting Screw Retainer
T17	Shifter Shoe (Repairs)
T22	Coupling Shaft Housing
T23	Shift Arm
T28	Shift Collar
T30	Coupling Shaft
T31	Drive Shaft
T32	Shift Fork (Superseded by T152)
T34	Gear Case Gasket
T36	Magnetic Drain Plug, 3/4 in.
T38	Shifter Shoe Stud (Repair)
T39	Shaft Nut
T42	Hex Hd Bolt, 3/8-24 x 1-1/4 in.
T43	Hex Nut, 3/8-24
T44	Cotter Pin, 1/8 x 1-3/4 in.

REF. NO.	DESCRIPTION
T47	Drive and Coupling Shafts Oil Seal
T48	Plain Washer, 1 in (1-3/4 in. Shafts Only)
T49	Lock Washer, 3/8 in.
T51	Retaining Ring
T55	Spirol Pin, SS, 1/4 x 1-1/4 in.
T56	Square Hd Pipe Plug, 3/4 in.
T58	Round Hd Drive Screw, No. 6 x 1/4 in.
T59	Cap Screw with Thread Sealant, 3/8-16 x 1-1/4 in.
T60	Ball Bearing
T62	Coupling Shaft Ball Bearing
T63	Drive Shaft Pilot Ball Bearing
T66	Drive Shaft Ball Bearing
T67	Drive Shaft Housing
T68	Shift Cover (Not Used with Bracket Mounted Shift)
T69	Shift Cover Gasket
T70	Drive Shaft Spacer or Tachometer Drive Gear
T145	Cap Screw, 1/2-13 x 3-1/2 in.
T146	Lock Washer, 1/2 in.
T152	Shift Fork (Supplied with shifter shoe T17 and shifter shoe studs T38. Supersedes T32 starting November 1966. If used for repairs on earlier PTO's, also supply pin T153. Enlarge pin hole in shaft to 5/16 in.)
T156	Shim, drive and coupling shaft housings, 0.005, 0.007 and 0.010 in. thick (1) 0.010 shim used with drive shaft housing T67. (Used starting November, 1971. Prior to this time, a 0.010 in. thick gasket was used both places.)
T167	Gasket Kit (Consists of: T20, T34, T39, T45, T69, T151, T156, T158)

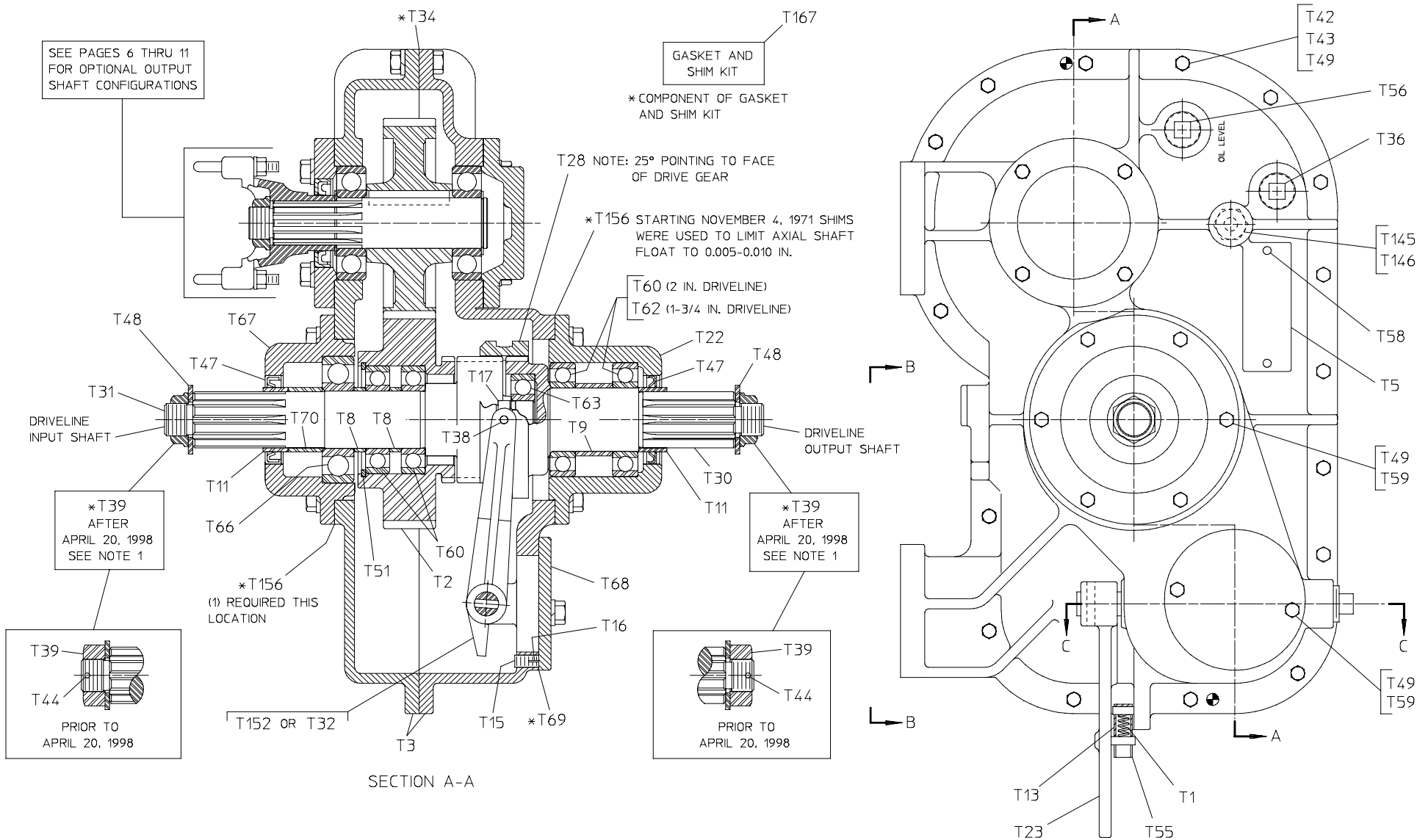

- NOTES:
1. 1-3/4 IN. DRIVELINE: TORQUE SELF LOCKING NUT TO 275-325 LB-FT.
2 IN. DRIVELINE: TORQUE SELF LOCKING NUT TO 475-525 LB-FT.
 2. SEE PAGE 5 FOR VIEW B-B AND SECTION C-C.

CASE AND DRIVELINE

Case and Driveline

REF. NO.	DESCRIPTION
T23	Shift Arm
T32	Shift Fork (Superseded by T152)
T37	Breather
T45	O-ring Packing (Use only with shaft T74)
T50	Lock Washer, 7/16 in.
T55	Spirol Pin, SS, 1/4 x 1-1/4 in.
T56	Square Hd Pipe Plug, 3/4 in.
T57	Street Elbow, 90 Degrees, 1/2 in.
T68	Shift Cover (Not Used with Bracket Mounted Shift)
T69	Shift Cover Gasket
T74	Shift Shaft (Superseded by T150)
T111	Suspension Pin
T112	Suspension Bracket
T124	Cap Screw, 7/16-14 x 1-1/4 in.

REF. NO.	DESCRIPTION
T128	Cotter Pin, 5/16 x 2-1/2 in.
T146	Lock Washer, 1/2 in.
T148	Cap Screw, 1/2-13 x 1 in. or 1-1/4 in.
T149	Sleeve Bearing
T150	Shift Shaft (Supersedes T74 beginning November, 1966)
T151	O-ring Packing (Use only with shaft T150)
T152	Shift Fork (Supplied with shifter shoe T17 and shifter shoe studs T38. Supersedes T32 starting 12/66. If used for repairs on earlier PTO's, also supply pin T153. Enlarge pin hole in shaft to 5/16 in.)
T153	Heavy Duty Spirol Pin, 5/16 x 1-1/4 in. (Use with fork T152)
T155	Upper Shift Shaft Bushing
T167	Gasket Kit (Consists of: T20, T34, T39, T45, T69, T151, T156, T158)

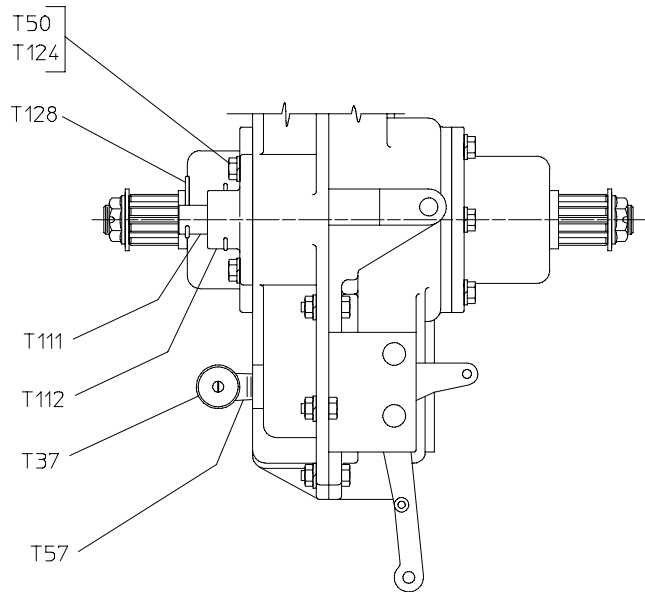

VIEW B-B

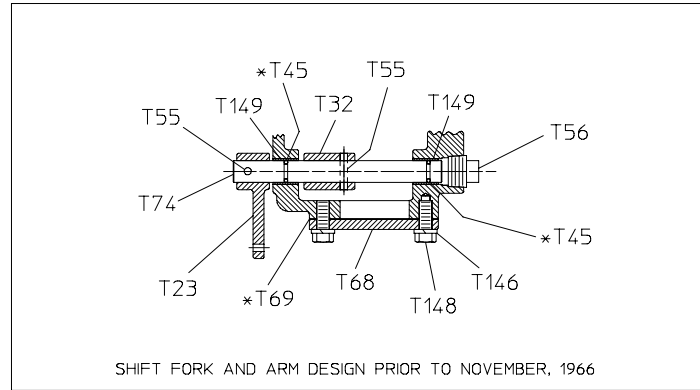

SHIFT FORK AND ARM DESIGN PRIOR TO NOVEMBER, 1966

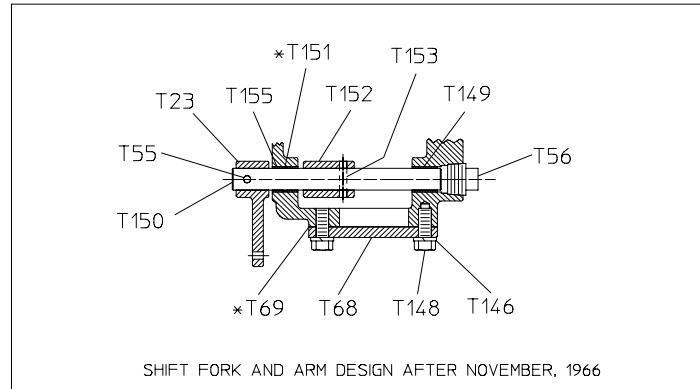

SHIFT FORK AND ARM DESIGN AFTER NOVEMBER, 1966

GASKET AND SHIM KIT — T167

*COMPONENT OF GASKET AND SHIM KIT

CASE AND DRIVELINE

Single Output Shaft

REF. NO.	DESCRIPTION
T20	Output Shaft Bearing Cover Gasket
T25	Output Shaft Bearing Cover
T26A	See Ref. No. T159
T26B	See Ref. No. T160
T26C	See Ref. No. T161
T27	Driven Shaft
T35	Driven Gear
T40	Cap Screw, 3/8-16 x 1-1/4 in.
T40A	See Ref. No. T162
T44	Cotter Pin, 1/8 x 1-3/4 in.
T46A	See Ref. No. T163
T46B	See Ref. No. T164
T46C	See Ref. No. T165
T49	Lock Washer, 3/8 in.
T52	Retaining Ring
T54	Square Key, 3/8 x 2-1/2 in.

REF. NO.	DESCRIPTION
T65	Output Shaft Ball Bearing
T65A	See Ref. No. T166
T133	Output Shaft Spacer
T134	End Yoke with U-Bolts
T144	Woodruff Key
T158	Output Shaft Nut
T159	Straight Output Shaft Seal and Bearing Cover (Formerly T26A)
T160	Splined Output Shaft Seal and Bearing Cover (Formerly T26B)
T161	Hydraulic Pump Adapter (Formerly T26C)
T162	Counterbore Screw, 3/8-16 x 1-1/4 in. (Formerly T40A)
T163	Straight Output Shaft Oil Seal (Formerly T46A)
T164	Splined Output Shaft Oil Seal (Formerly T46B)
T165	Hydraulic Pump Output Shaft Oil Seal (Formerly T46C)
T166	Hydraulic Drive Output Ball Bearing (Formerly T65A)
T167	Gasket Kit (Consists of: T20, T34, T39, T45, T69, T151, T156, T158)
T236	Hi-Collar Lockwasher, 3/8 in.

* T158
AFTER
APRIL 20, 1998
TORQUE TO
275-375 LB-FT

T158
T44
PRIOR TO
APRIL 20, 1998

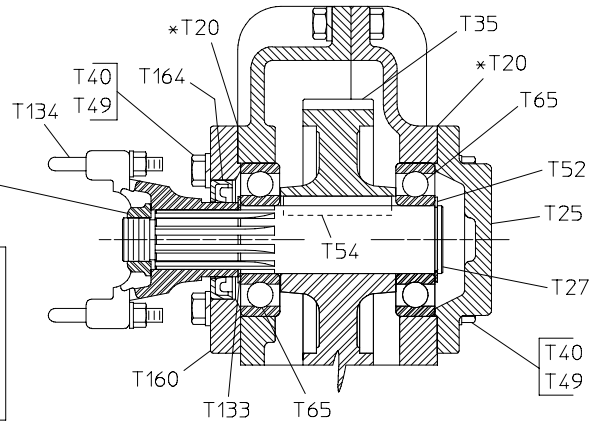

DETAIL A
MODELS: TML-1CA, TML-2CA

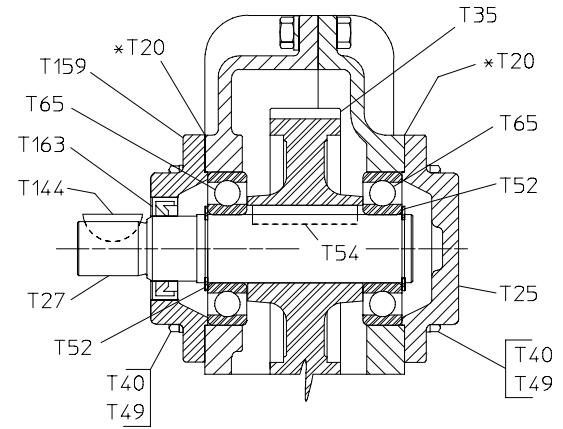

DETAIL B
MODELS: TML-1CB, TML-2CB

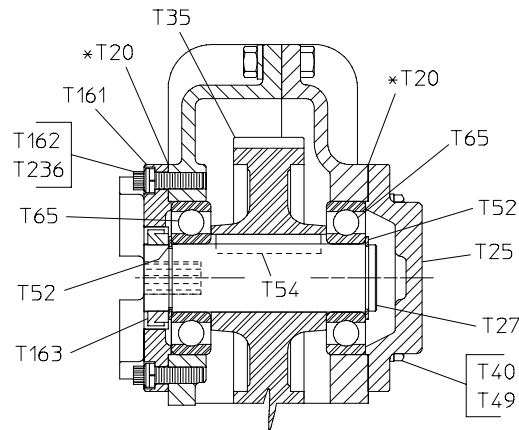

MODELS:
TML-1DA, TML-2DA
TML-1DB, TML-2DB
TML-1CF
TML-2CF — SAE CLASS B

DETAIL C

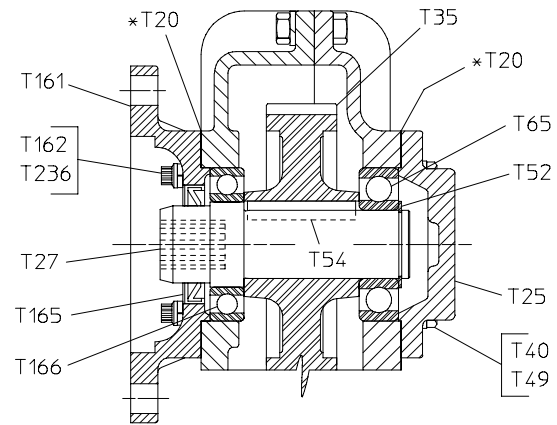

MODELS:
TML-1EA, TML-2EA
TML-2EB
TML-1CF
TML-2CF — SAE CLASS C

DETAIL D

GASKET AND
SHIM KIT — T167

* COMPONENT OF GASKET
AND SHIM KIT

OPTIONAL OUTPUT SHAFT CONFIGURATIONS

(SINGLE OUTPUT)

Dual Output Shaft

REF. NO.	DESCRIPTION
T20	Output Shaft Bearing Cover Gasket
T26A	See Ref. No. T159
T26B	See Ref. No. T160
T26C	See Ref. No. T161
T27	Driven Shaft
T35	Driven Gear
T40	Cap Screw, 3/8-16 x 1-1/4 in.
T40A	See Ref. No. T162
T44	Cotter Pin, 1/8 x 1-3/4 in.
T46A	See Ref. No. T163
T46B	See Ref. No. T164
T46C	See Ref. No. T165
T49	Lock Washer, 3/8 in.
T52	Retaining Ring
T54	Square Key, 3/8 x 2-1/2 in.

REF. NO.	DESCRIPTION
T65	Output Shaft Ball Bearing
T65A	See Ref. No. T166
T133	Output Shaft Spacer
T134	End Yoke with U-Bolts
T144	Woodruff Key
T158	Output Shaft Nut
T159	Straight Output Shaft Seal and Bearing Cover (Formerly T26A)
T160	Splined Output Shaft Seal and Bearing Cover (Formerly T26B)
T161	Hydraulic Pump Adapter (Formerly T26C)
T162	Counterbore Screw, 3/8-16 x 1-1/4 in. (Formerly T40A)
T163	Straight Output Shaft Oil Seal (Formerly T46A)
T164	Splined Output Shaft Oil Seal (Formerly T46B)
T165	Hydraulic Pump Output Shaft Oil Seal (Formerly T46C)
T166	Hydraulic Drive Output Ball Bearing (Formerly T65A)
T167	Gasket Kit (Consists of: T20, T34, T39, T45, T69, T151, T156, T158)
T236	Hi-Collar Lockwasher, 3/8 in.

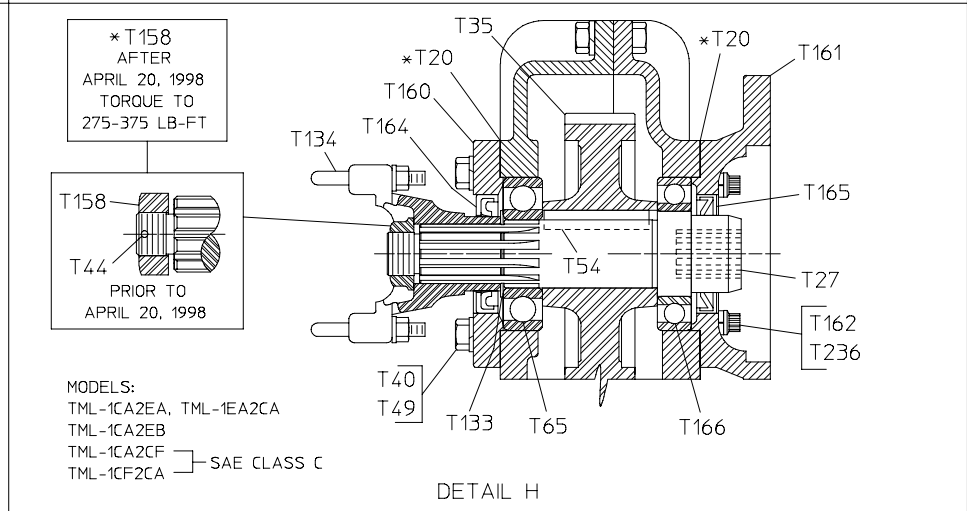
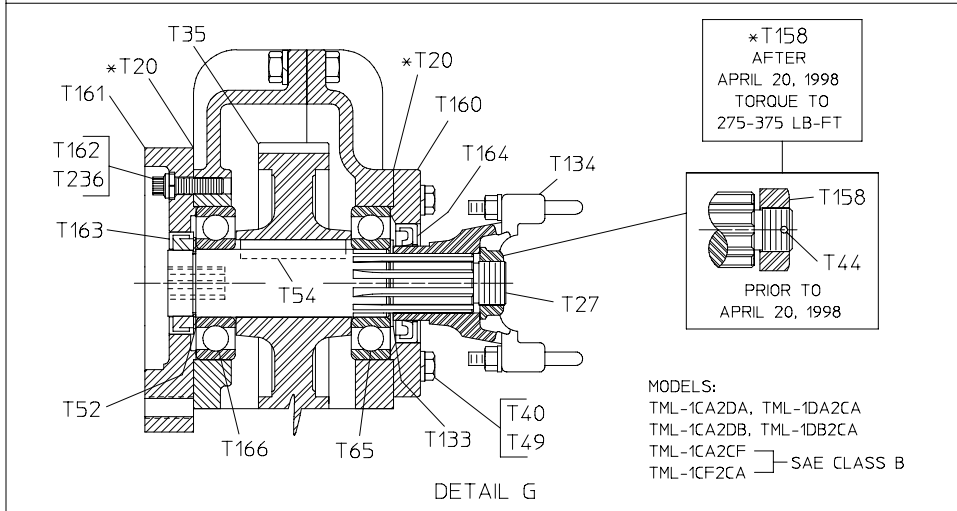
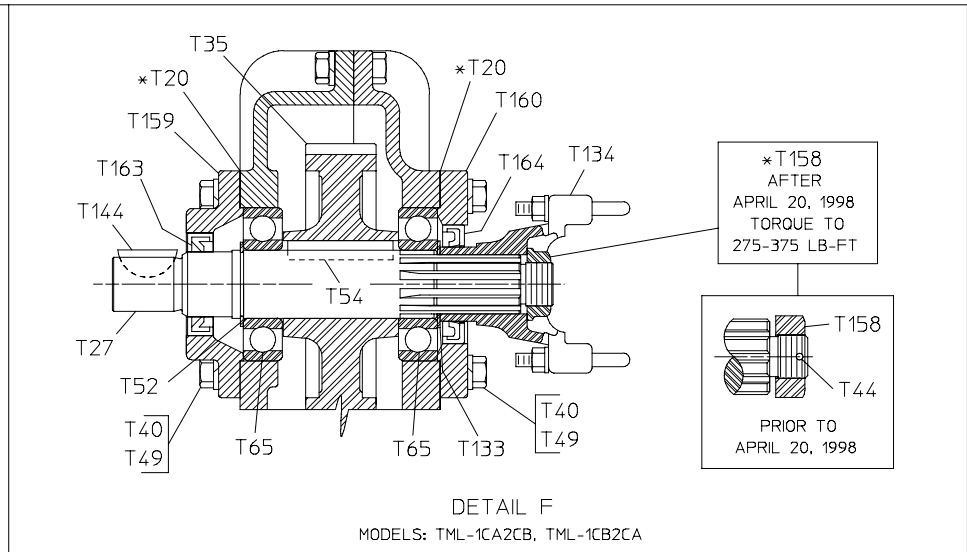
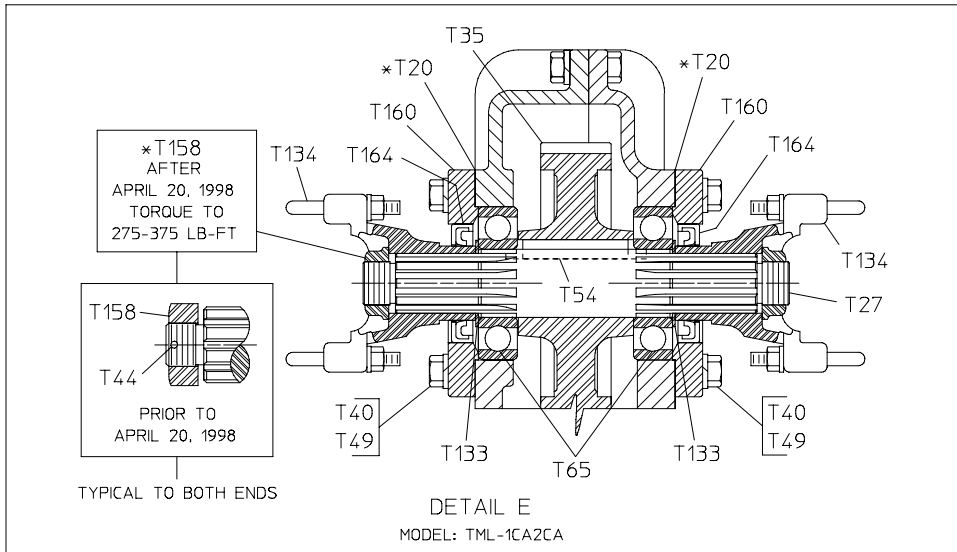

GASKET AND SHIM KIT — T167

* COMPONENT OF GASKET AND SHIM KIT

OPTIONAL OUTPUT SHAFT CONFIGURATIONS

(DUAL OUTPUT)

Dual Output Shaft

REF. NO.	DESCRIPTION
T20	Output Shaft Bearing Cover Gasket
T26C	See Ref. No. T161
T27	Driven Shaft
T35	Driven Gear
T40A	See Ref. No. T162
T46A	See Ref. No. T163
T46C	See Ref. No. T165
T52	Retaining Ring
T54	Square Key, 3/8 x 2-1/2 in.

REF. NO.	DESCRIPTION
T65	Output Shaft Ball Bearing
T65A	See Ref. No. T166
T133	Output Shaft Spacer
T161	Hydraulic Pump Adapter (Formerly T26C)
T162	Counterbore Screw, 3/8-16 x 1-1/4 in. (Formerly T40A)
T163	Straight Output Shaft Oil Seal (Formerly T46A)
T165	Hydraulic Pump Output Shaft Oil Seal (Formerly T46C)
T166	Hydraulic Drive Output Ball Bearing (Formerly T65A)
T167	Gasket Kit (Consists of: T20, T34, T39, T45, T69, T151, T156, T158)
T169	Output Shaft Spacer
T170	Hydraulic Pump Adapter
T236	Hi-Collar Lockwasher, 3/8 in.

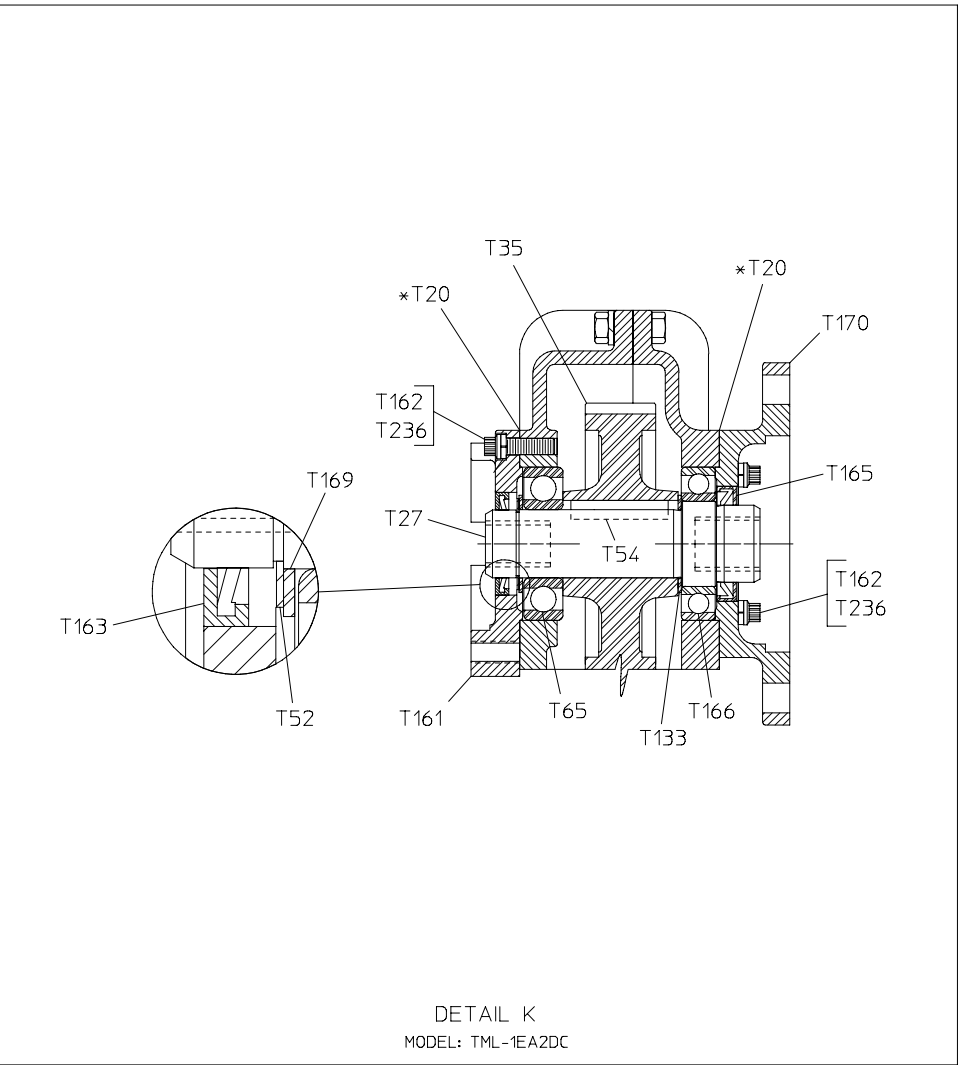
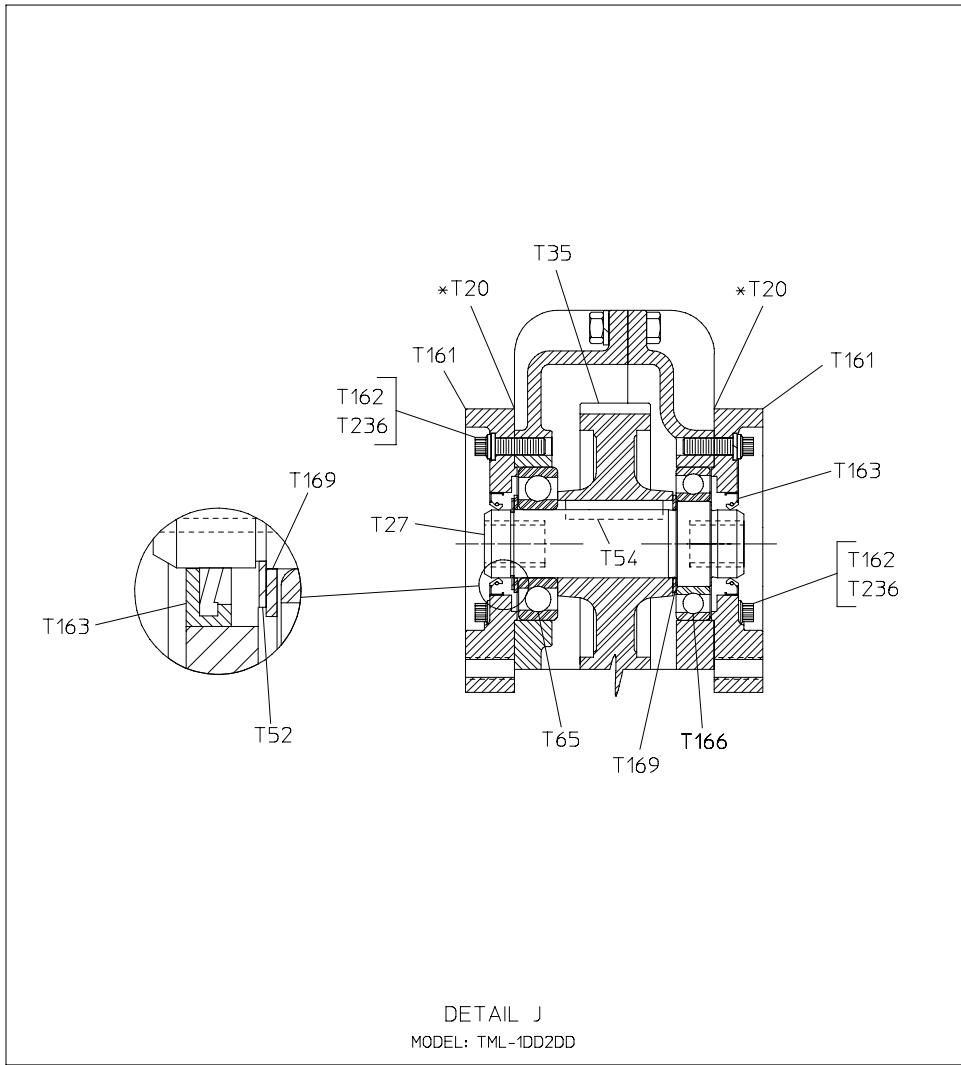

GASKET AND SHIM KIT — T167

* COMPONENT OF GASKET AND SHIM KIT

OPTIONAL OUTPUT SHAFT CONFIGURATIONS

(DUAL OUTPUT)

Optional
Tachometer - Driveline Input Shaft
Governor Drive - Output Shaft

REF. NO.	DESCRIPTION
T3	Gear Case Assembly
T11	Oil Seal Sleeve
T20	Output Shaft Bearing Cover Gasket
T22	Coupling Shaft Housing
T25	Output Shaft Bearing Cover
T31	Drive Shaft
T35	Driven Gear
T47	Drive and Coupling Shaft Oil Seal
T50	Lockwasher, 7/16 in.
T52	Retaining Ring
T65	Output Shaft Ball Bearing

REF. NO.	DESCRIPTION
T67	Drive Shaft Housing
T70	Drive Shaft Spacer or Tachometer Drive Gear
T85	Tachometer or Speedometer Driven Gear
T86	Tachometer or Speedometer Gear Sleeve
T87	Tachometer or Speedometer Gear Bushing
T88	Tachometer or Speedometer Gear Cap
T124	Cap Screw, 7/16-14 x 1-1/4 in.
T140	Governor Spinner Drive Gear
T141	Governor Spinner Oil Seal
T167	Gasket Kit (Consists of: T20, T34, T39, T45, T69, T151, T156, T158)

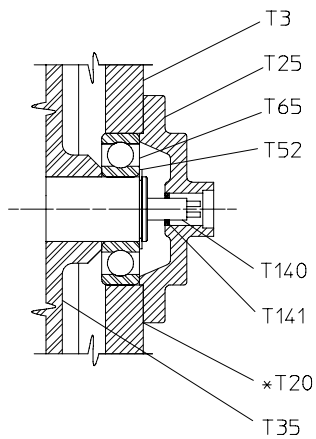

OPTIONAL GOVERNOR DRIVE

(OUTPUT SHAFT)

NO LONGER AVAILABLE AFTER MARCH 1, 1995

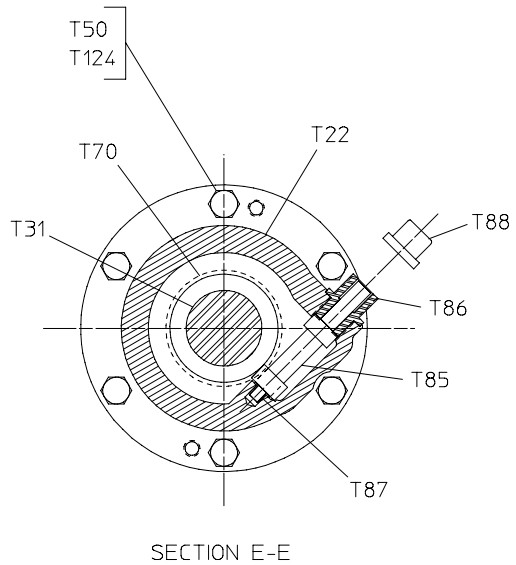

OPTIONAL TACHOMETER

(DRIVELINE INPUT SHAFT)

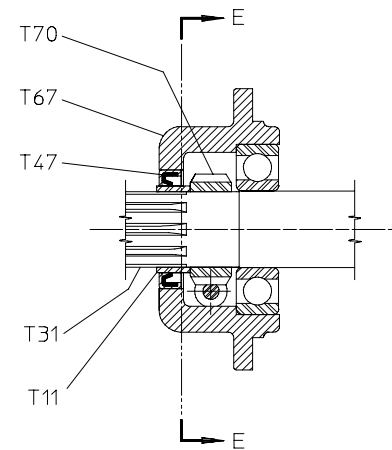

GASKET AND SHIM KIT T167

*COMPONENT OF GASKET AND SHIM KIT

Optional Driveline Output Shaft

Speedometer

Parking Brake Provision

REF. NO.	DESCRIPTION
T9	Coupling Shaft Bearing Spacer
T11	Oil Seal Sleeve
T22	Coupling Shaft Housing
T30	Coupling Shaft
T47	Drive and Coupling Shaft Oil Seal
T50	Lockwasher, 7/16 in.
T60	Ball Bearing
T62	Coupling Shaft Ball Bearing
T67	Drive Shaft Housing
T70	Drive Shaft Spacer or Tachometer Drive Gear

REF. NO.	DESCRIPTION
T85	Tachometer or Speedometer Driven Gear
T86	Tachometer or Speedometer Gear Sleeve
T87	Tachometer or Speedometer Gear Bushing
T124	Cap Screw, 7/16-14 x 1-1/4 in.
T132	Drain Pipe
T135	Woodruff Key
T136	Speedometer Gear Spacer
T137	Speedometer Gear Bushing Retainer
T138	Speedometer Drive Gear
T168	Pipe Plug, 1/8 in.

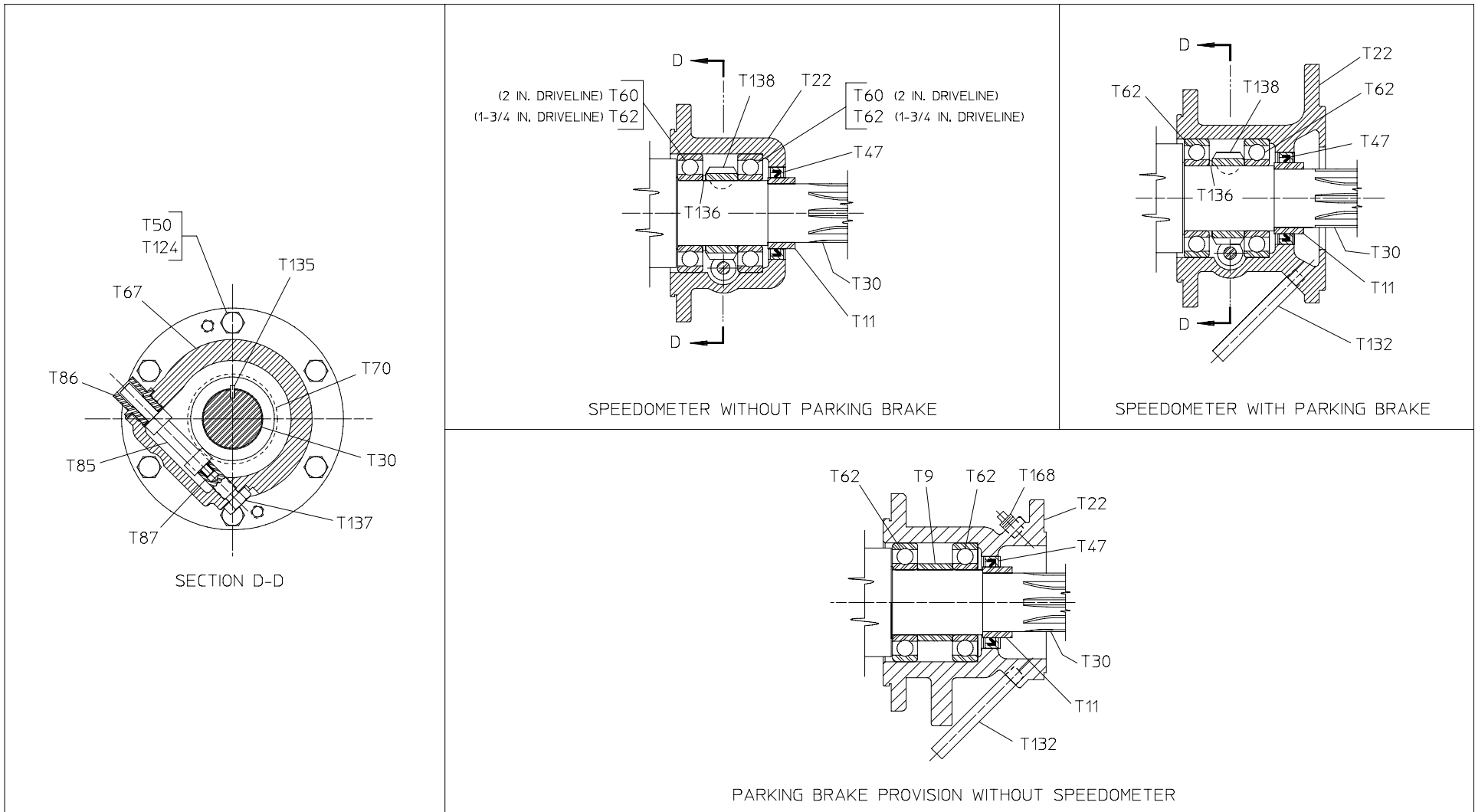

OPTIONAL SPEEDOMETER AND PARKING BRAKE PROVISION

(DRIVELINE OUTPUT SHAFT)