



CPK-5 Series Operation and Maintenance Instructions

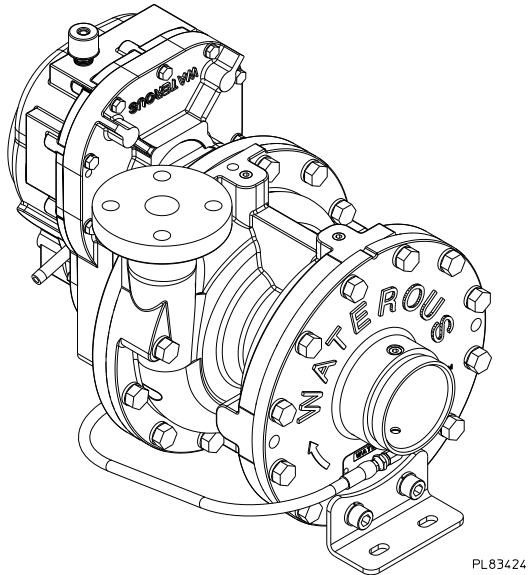

Table of Contents

- Safety Information**2, 3
- Introduction**4
- General Description**.....4
- Pump Models**.....4
- Operating Instructions**
 - Pumping from Water Tank-----5
 - Pumping from in Relay -----6
 - Pumping from Draft -----7
 - Mechanical Seal -----8
 - Fire Hose Testing -----9
- Lubrication**.....10



Read through the installation instructions carefully before using your Waterous CR/CRU-1/CRU-2 Series Pump

NOTE: Instructions subject to change without notice

F-1031, Section 2126 (Revised: 8/24/18)



Read through the safety information and operating instructions carefully before using your Waterous Pump.

Safety Information

WARNING

Death or serious personal injury might occur if proper operating procedures are not followed. The pump operator, as well as individuals connecting supply or discharge hoses to the apparatus must be familiar with these pump operating instructions as well as other operating instructions and manuals for the apparatus, water hydraulics and component limitation.

WARNING

Pressure Hazard. May result in personal injury.
Prior to connection or removal of hoses, caps or other closures with pump intake or pump discharge connections, relieve pressure by opening drains or bleeder valves. Bleeder valves should also be used while filling a hose connected to an intake with fluids.

WARNING

Scalding Water Hazard. May result in serious burns.

When operating the pump, be sure to open at least one discharge valve slightly to prevent the pump from overheating. If the pump runs for a few minutes completely closed, it may heat the water enough to scald someone when the valve is opened. Overheating can damage the packing, seals and other pump parts. If the apparatus builder has installed a by-pass system or other provision designed to prevent overheating, opening a discharge valve may be unnecessary.

WARNING

Unexpected Truck Movement. May result in serious personal injury or death.

Failure to properly shift transmission in accordance to the transmission operating instructions may result in unexpected truck movement which may result in serious personal injury or death.



Read through the safety information and operating instructions carefully before using your Waterous Pump.

Safety Information



WARNING

Hose Testing Hazard. May result in serious personal injury.

Due to a potential for catastrophic hose failure during service testing of fire hose, it is vital that safety precautions be taken to prevent exposure of anyone to this danger. Fire pumps on fire department apparatus are not designed for and should not be used for service testing of fire hoses. Hose testing machines should be used for service testing of fire hoses.



WARNING

Pressure Hazard. May result in serious personal injury.

If a fire pump on a fire department apparatus is used for service testing of fire hoses, the procedures in NFPA 1962 **MUST be followed** including the use of a fire department gate valve with a ¼-inch (6 mm) hole drilled through the gate installed between the fire apparatus discharge outlet and the hose test layout to prevent a volume surge from the pump in the event a hose bursts during testing.



WARNING

Scalding Water Hazard. May result in serious burns.

If a fire pump on a fire department apparatus is used for service testing of fire hoses, pump discharge water must be circulated through a by-pass system or discharged through a slightly open discharge valve, or some other provision must be used to prevent overheating. If the pump runs for a few minutes without adequate flow through the pump, water may be heated enough to scald someone when a valve is opened.

Introduction

This instruction contains the information needed for operation and maintenance of CPK-5 Series pumps.

General Description

The CPK-5 series pumps are a two-stage pump providing performance of 320 GPM @ 1350 PSI (1211 l/min @ 93 bar).

CPK-5 Series

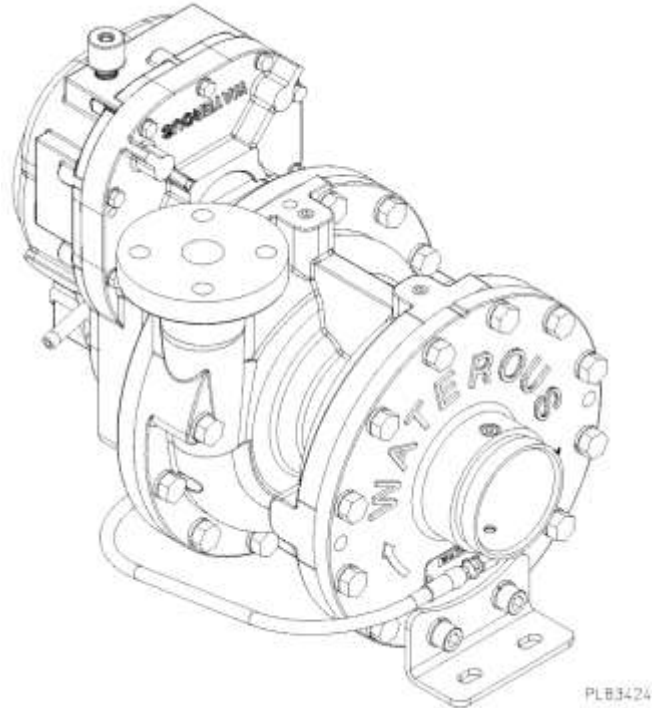
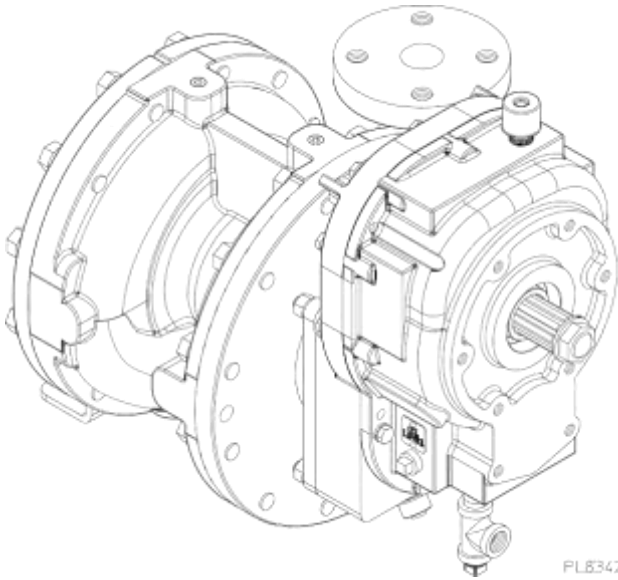

Operating Instructions

Pumping from Tank

WARNING

Pressure Hazard. May result in personal injury or death.

Prior to connection of hoses, caps or other closures with pump intake or pump discharge connections, relieve pressure by opening drains.

WARNING

Scalding Water Hazard. May result in serious burns.

When operating the pump, be sure to open at least one discharge valve slightly to prevent the pump from overheating. If the pump runs for a few minutes completely closed, it may heat the water enough to scald someone when the valve is opened. Overheating can damage the packing, seals and other pump parts. If the apparatus builder has installed a by-pass system or other provision designed to prevent overheating, opening a discharge valve may be unnecessary.

1. Open valve(s) in piping between tank and pump intake and at least one discharge valve.
2. Allow about 30 seconds for water to flow into pump.

WARNING

Unexpected Truck Movement. May result in personal injury or death.

Failure to properly shift transmission in accordance with the transmission operating instructions may result in unexpected truck movement which may result in serious personal injury or death.

CAUTION

Do not attempt to pump more water than is available from the tank. Always make sure the intake pressure compound gage reading stays above zero.

CAUTION

Pump cannot be deadheaded for more than 60 seconds. May cause the pump to overheat and damage the pump.

3. Set relief valves or other pressure governing device to desired pressure.
4. Engage pump drive, accelerate engine to obtain desired discharge pressure and capacity.

After Pumping

WARNING

Pressure Hazard. May result in personal injury or death.

Prior to removal of hoses, caps or other closures with pump intake or pump discharge connections, relieve pressure by opening drains.

1. Disengage pump drive.
2. If pumping anything but clean water, remove all intake and discharge caps, open all valves and open all drains. Flush entire system with clean, fresh water for several minutes to remove all traces of impurities.
3. Close all drains and install intake and discharge caps.

Pumping in Relay

WARNING

Pressure Hazard. May result in personal injury or death.

Prior to connection of hoses, caps or other closures with pump intake or pump discharge connections, relieve pressure by opening drains or bleeder valves.

WARNING

Scalding Water Hazard. May result in serious burns.

When operating the pump, be sure to open at least one discharge valve slightly to prevent the pump from overheating. If the pump runs even for a few minutes completely closed it may heat the water enough to scald someone when the valve is opened. Overheating can damage the packing, seals and other pump parts. If the apparatus builder has installed a by-pass system or other provision designed to prevent overheating, opening a discharge valve may be unnecessary.

WARNING

Unexpected Truck Movement. May result in personal injury or death.

Failure to properly shift transmission in accordance with the transmission operating instructions may result in unexpected truck movement which may result in serious personal injury or death.

1. Open intake and other valves as necessary to allow water or fuel to enter the pump.

NOTE: Bleeder valves should be used while filling a hose connected to an intake with water.

CAUTION

Limit intake pressure to 75 psi (5.2 bar) if possible. Although the pump will operate properly with higher intake pressure, such operation will greatly accelerate mechanical seal wear.

2. Open discharge valves and accelerate engine to obtain desired discharge pressure and capacity.
3. Set relief valves or other pressure governing device to desired pressure.

CAUTION

Do not attempt to pump more water than is available from the hydrant or relaying pumper. Always make sure the intake pressure compound gage reading stays above zero.

CAUTION

Pump canaded for more than 60 seconds. May cause the pump to overheat and damage the pump.

NOTE: Some fire departments operate at a minimum intake pressure of 10 psi (.7 bar) when pumping in relay to prevent a "soft" intake hose from collapsing.

After Pumping

WARNING

Pressure Hazard. May result in personal injury or death.

Prior to removal of hoses, caps or other closures with pump intake or pump discharge connections, relieve pressure by opening drains or bleeder valves.

4. Disengage pump drive.
5. If pumping anything but clean water, remove all intake and discharge caps, open all valves and open all drains. Flush entire system with clean, fresh water for several minutes to remove all traces of impurities.
6. If pump is kept full of water when not in use, make sure water is clean and non-corrosive. Make sure the pump is completely full or completely drained (never partially full).

CAUTION

7. Close all drains and install intake and discharge caps.
8. If truck is equipped with a priming pump, operate it until fluid is discharged from priming pump discharge pipe. If equipped with a priming tank, check fluid level and refill if necessary.

Pumping from Draft

WARNING

Pressure Hazard. May result in personal injury or death.

Prior to connection of hoses, caps or other closures with pump intake or pump discharge connections, relieve pressure by opening drains.

WARNING

Scalding Water Hazard. May result in serious burns.

When operating the pump, be sure to open at least one discharge valve slightly to prevent the pump from overheating. If the pump runs even for a few minutes completely closed it may heat the water enough to scald someone when the valve is opened. Overheating can damage the packing, seals and other pump parts. If the apparatus builder has installed a by-pass system or other provision designed to prevent overheating, opening a discharge valve may be unnecessary.

WARNING

Unexpected Truck Movement. May result in personal injury or death.

Failure to properly shift transmission in accordance with the transmission operating instructions may result in unexpected truck movement which may result in serious personal injury or death.

NOTE: To get full capacity, quick prime and maintain pump efficiency:

- Position vehicle as near as possible to water supply.
- Avoid humps and sharp bends in intake hose. Make sure no part of hose is higher than pump inlet. (Air pockets in intake hose may cause loss of prime or erratic pump action, and may reduce pump capacity.)
- Make sure all intake connections are tight and discharge valves are closed.
- Immerse intake strainer at least two feet below water or fuel surface to prevent pump from drawing air. (Whirlpools forming above intake strainer indicate that strainer is too close to surface of water.)

e) Make sure intake strainer is far enough from bottom to prevent sand, gravel and other foreign matter from being drawn into the pump.

- Engage pump.
- Prime the pump (see separate instructions supplied with primer).
- Open discharge Valves, and accelerate engine to obtain desired discharge pressure and capacity.
- Set relief valves or other pressure governing device to desired pressure.

CAUTION

Pump cannot be deadheaded for more than 60 seconds. May cause the pump to overheat and damage the pump.

After Pumping

WARNING

Pressure Hazard. May result in personal injury or death.

Prior to removal of hoses, caps or other closures with pump intake or pump discharge connections, relieve pressure by opening drains.

- Disengage pump drive.
- If pumping anything but clean water, remove all intake and discharge caps, open all valves and open all drains. Flush entire system with clean, fresh water for several minutes to remove all traces of impurities.

CAUTION

Freezing water hazard. May cause damage to the pump.

If the pump is exposed to freezing temperatures, drain all water from pump, lines and accessories.

- Close all drains and install intake and discharge caps.

Mechanical Seal

A mechanical shaft seal is used and no adjustment is required. When the pump operates, the water being pumped cools and lubricates the shaft seal to prevent it from overheating.

If the mechanical seal leaks, replace the entire seal.

CAUTION

Prolonged dry pump operation or operating a dry pump at high speeds will reduce the life of the mechanical seal.

Fire Hose Testing



WARNING

Hose Testing Hazard. May result in serious personal injury.

Due to a potential for catastrophic hose failure during service testing of fire hose, it is vital that safety precautions be taken to prevent exposure of anyone to this danger. Fire pumps on fire department apparatus are not designed for and should not be used for service testing of fire hoses. Hose testing machines should be used for service testing of fire hoses.

NFPA 1962 *Standard for the Inspection, Care, and use of Fire Hose, Couplings, and Nozzles and the Service Testing of Fire Hose* provides requirements and testing procedures for service-testing fire hose at least annually. NFPA 1962 includes procedures for service testing with either a hose testing machine or with a pump on a fire department fire apparatus.



WARNING

Pressure Hazard. May result in serious personal injury.

If a fire pump on a fire department apparatus is used for service testing of fire hoses, the procedures in NFPA 1962 **MUST be followed** including the use of a fire department gate valve with a ¼-inch (6 mm) hole drilled through the gate installed between the fire apparatus discharge outlet and the hose test layout to prevent a volume surge from the pump in the event a hose bursts during testing.

During fire hose testing with a fire pump on a fire department fire apparatus, the fire pump is required to be operated at high discharge pressure with little or no flow out of the apparatus.



WARNING

Scalding Water Hazard. May result in serious burns.

If a fire pump on a fire department apparatus is used for service testing of fire hoses, pump discharge water must be circulated through a by-pass system or discharged through a slightly open discharge valve, or some other provision must be used to prevent overheating. If the pump runs for a few minutes without adequate flow through the pump, water may be heated enough to scald someone when a valve is opened.

CAUTION

If a fire pump on a fire department apparatus is used for service testing of fire hoses, operating the pump at high discharge pressure with little or no flow may result in severe damage to the pump.

Lubrication

1. Check the lubrication fluid level monthly by checking the sight plug or by removing the oil level plug. The fluid should be level with the bottom of the oil level hole.

CAUTION

Low or excessive lubrication fluid may cause damage.

If lubricant fluid level is low, locate source of leak and repair. If level is high, loosen oil level plug and drain until proper level is reached. If any water drains out, change lubrication fluid and determine source of water leakage and repair.

2. Change lubrication fluid and clean breather once a year or after each 100 hours of operation, whichever comes first. Lubrication fluid may be added through the oil level hole or by removing the breather and adding fluid through the opening. Synthetic gear lube should be used.
3. Quantities of lubrication fluid if system is completely drained and refilled:

K Series Transmission

Gear lube spec: 75W-90 full synthetic.

Capacity:

Inverted mounting: 1.2 quarts

Horizontal mounting: 1.5 quarts

Vertical mounting; 1.6 quarts

(Capacity measurements are approximate and include the transmission, oil cooler, and oil pump. Hoses and fittings are not included. Adjust accordingly to application).

Oil fill procedure:

1. With oil level plug installed, fill transmission with 1.5 quarts of gear lube.
2. Run electric oil pump for 1 minute.
3. Stop oil pump.
4. Remove oil level plug.
5. Drain excess oil or add oil until a small stream of oil runs out oil level hole.
6. Install oil level plug.
7. Repeat steps 2-6 until no additional oil is required.