

Table of Contents

Safety Information	2
Introduction	3
General Description	3
Pump Mounting - General Information	3
Pump Mounting	4-9
Pump and Transmission.....	4-7
Oil Pump and Cooler	8-9
Final Checks	10
Lubrication.....	10
Testing	10



Read through the installation instructions carefully before installing your Waterous CPK-5 Series Fire Pump.

NOTE: Instructions subject to change without notice



Read through and communicate safety information to the end user of this Waterous Fire Pump.

Safety Information

WARNING

Death or serious personal injury might occur if proper operating procedures are not followed. The pump operator, as well as individuals connecting supply or discharge hoses to the apparatus must be familiar with pump operating instructions as well as other operating instructions and manuals for the apparatus, water hydraulics and component limitation.

WARNING

Pressure Hazard. May result in personal injury.
Prior to connection or removal of hoses, caps or other closures with pump intake or pump discharge connections, relieve pressure by opening drains or bleeder valves. Bleeder valves should also be used while filling a hose connected to an intake with water.

WARNING

Scalding Water Hazard. May result in serious burns.
When operating the pump, be sure to open at least one discharge valve slightly to prevent the pump from overheating. If the pump runs for a few minutes completely closed, it may heat the water enough to scald someone when the valve is opened. Overheating can damage the packing, seals and other pump parts. If the apparatus builder has installed a by-pass system or other provision designed to prevent overheating, opening a discharge valve may be unnecessary.

Introduction

This instruction covers the installation of a Waterous CPK-5 Series fire pump. The CPK-5 is rated at 320 GPM @ 1350 PSI (1200 l/min @ 93 bar)

The CPK-5 is available with the following transmission:

- Extra Heavy Duty K Series - The K transmission is a gear driven transmission designed primarily to be driven by a power take-off or power divider. (see Figure 1).

The following installation instructions are available:

- Priming System, F-1031, Section 3006
- Manifold Drain Valves, F-1031, Section 3008
- Pressure Control System, F-1031, Section 3010
- Overheat Protection Manager, F-1031, Section 3015

Before proceeding with the installation of the CL, read the instructions carefully. Check the appropriate dimensional drawings in the Engineering Manual as needed.

Pump Mounting - General Information

Select a mounting location which will make the pump and its accessories readily accessible for maintenance.

Table 2 gives maximum universal joint angles for installations where propeller shaft flanges are parallel and yokes are aligned. Refer to this table when positioning a pump to determine proper shaft angles. Be sure to keep at least a minimum of 1° U-joint operating angle, but do not exceed those specified in the table. This is the preferred method of propeller shaft installation. For additional information on this method, or for alternative methods, see driveshaft installation guidelines such as Spicer®/Driveshaft Installation Techniques, J-3311.

CAUTION

Be sure the propeller shafts used are of the slip-joint design. Frame deflection, temperature changes and similar factors may cause a propeller shaft without slip-joints to produce severe axial loads on the bearings and damage the pump.

Table 2. Maximum U-joint Operating Angles

Driveshaft RPM	Maximum Operating Angle
5000	3.2°
4500	3.7°
4000	4.2°
3500	5.0°
3000	5.8°
2500	7.0°
2000	8.7°
1500	11.5°

NOTE: The angles shown in Table 2 are the maximum recommended U-joint operating angles and are directly related to the speed of the driveshaft. Any U-joint operating angle greater than 3° will lower the U-joint life and may cause vibration¹.

¹ From Spicer Driveshaft Installation Techniques, Form J-3311 dated 5/94.

Pump Mounting - CPK-5 Series

Figure 1 shows the mounting areas on a CPK-5 pump. To mount the pump/transmission to the vehicle chassis, construct a bracket that will span the frame rails of the vehicle and attach to the transmission mounting holes (several locations are provided).

NOTE: Before installation, make sure your pump has the right rotation as compared to the driveshaft rotation (see dimensional drawings for correct rotation configurations).

Position the pump/transmission within the vehicle frame rails and secure the brackets (not supplied) to the vehicle frame.

Support the pump by using the mounting plate on the pump as shown in Figure 1.

NOTE: Tighten the mounting screws to standard torque specifications.

Finally, provide adequate support for any intake and discharge piping assemblies.

Figure 1. CPK-5 Mounting Diagram

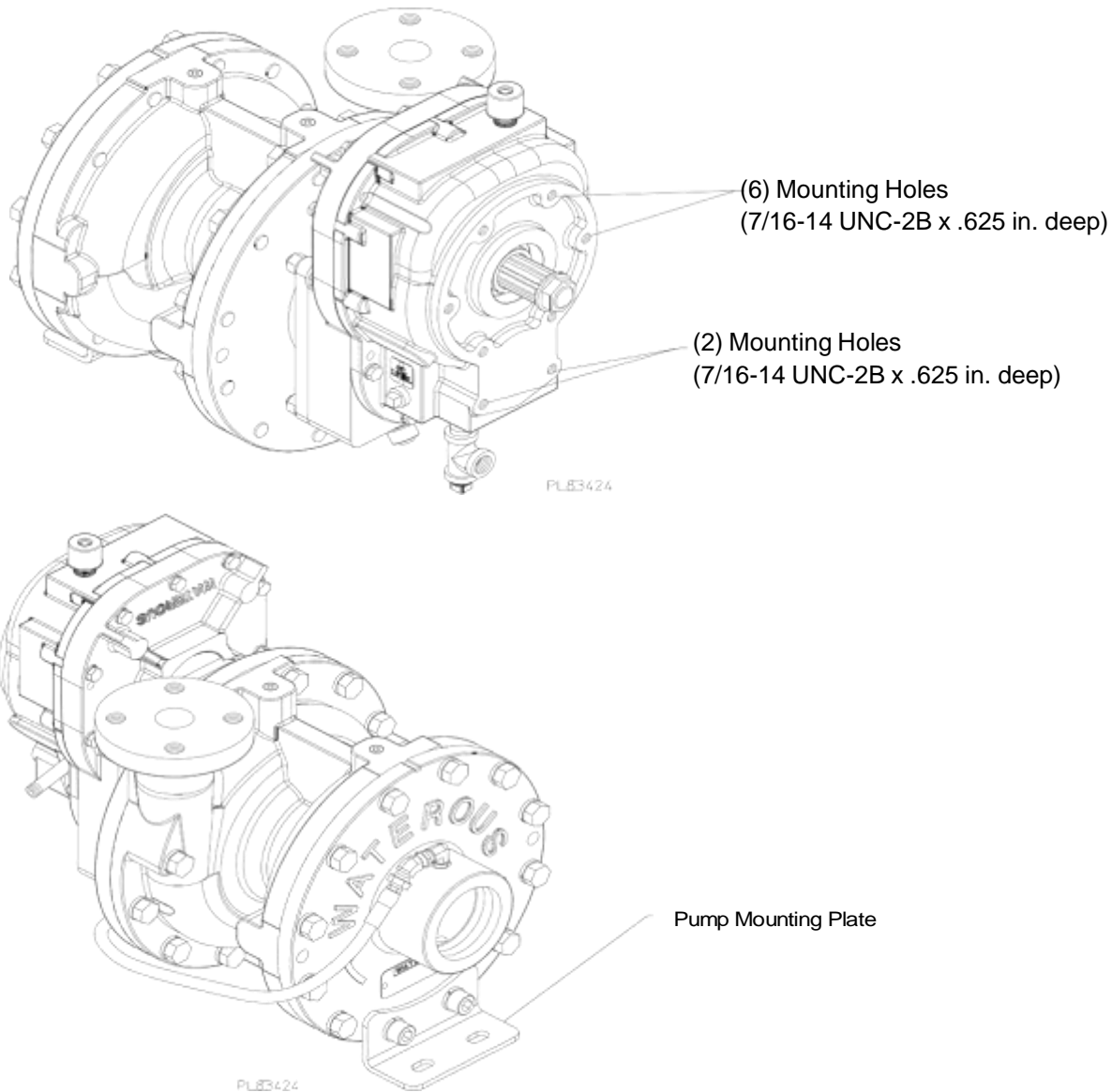

Pump Mounting – CPK 5 Series (con't)

Figure 2. Pump Dimensions,
Inverted Transmission

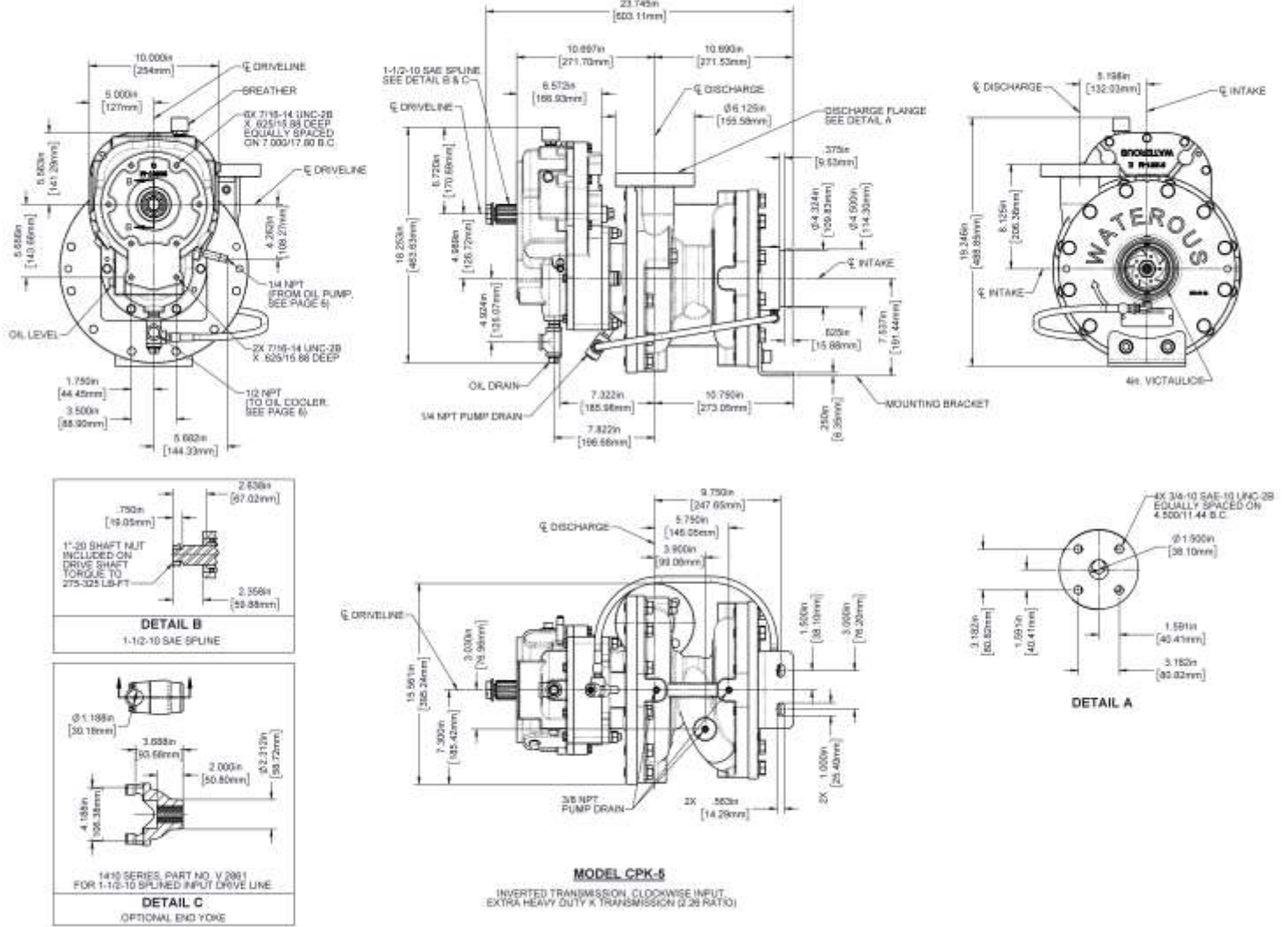

Pump Mounting – CPK 5 Series (con't)

Figure 3. Pump Dimensions, Horizontal Transmission

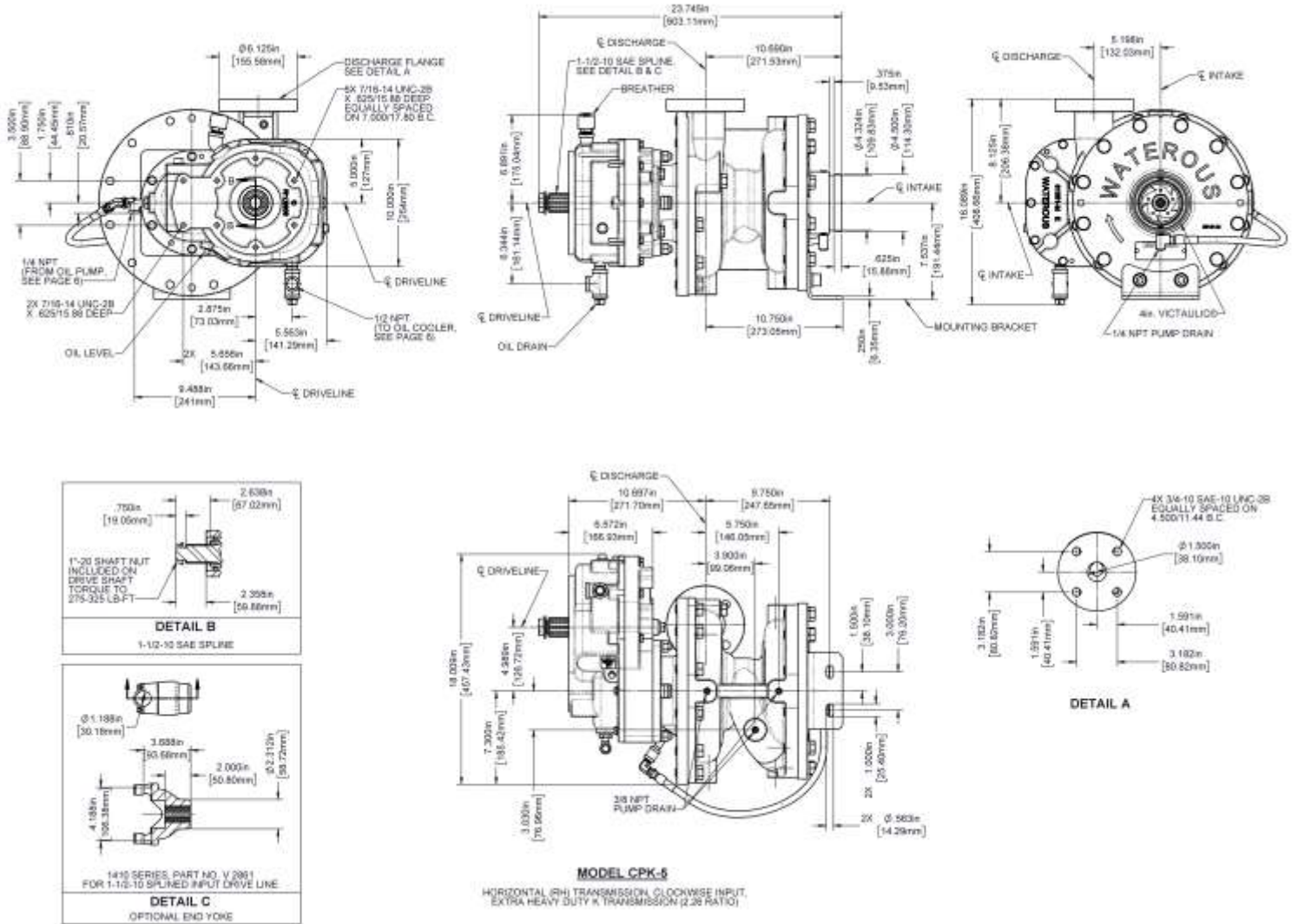

Pump Mounting – CPK 5 Series (con't)

Figure 3. Pump Dimensions, Vertical Transmission

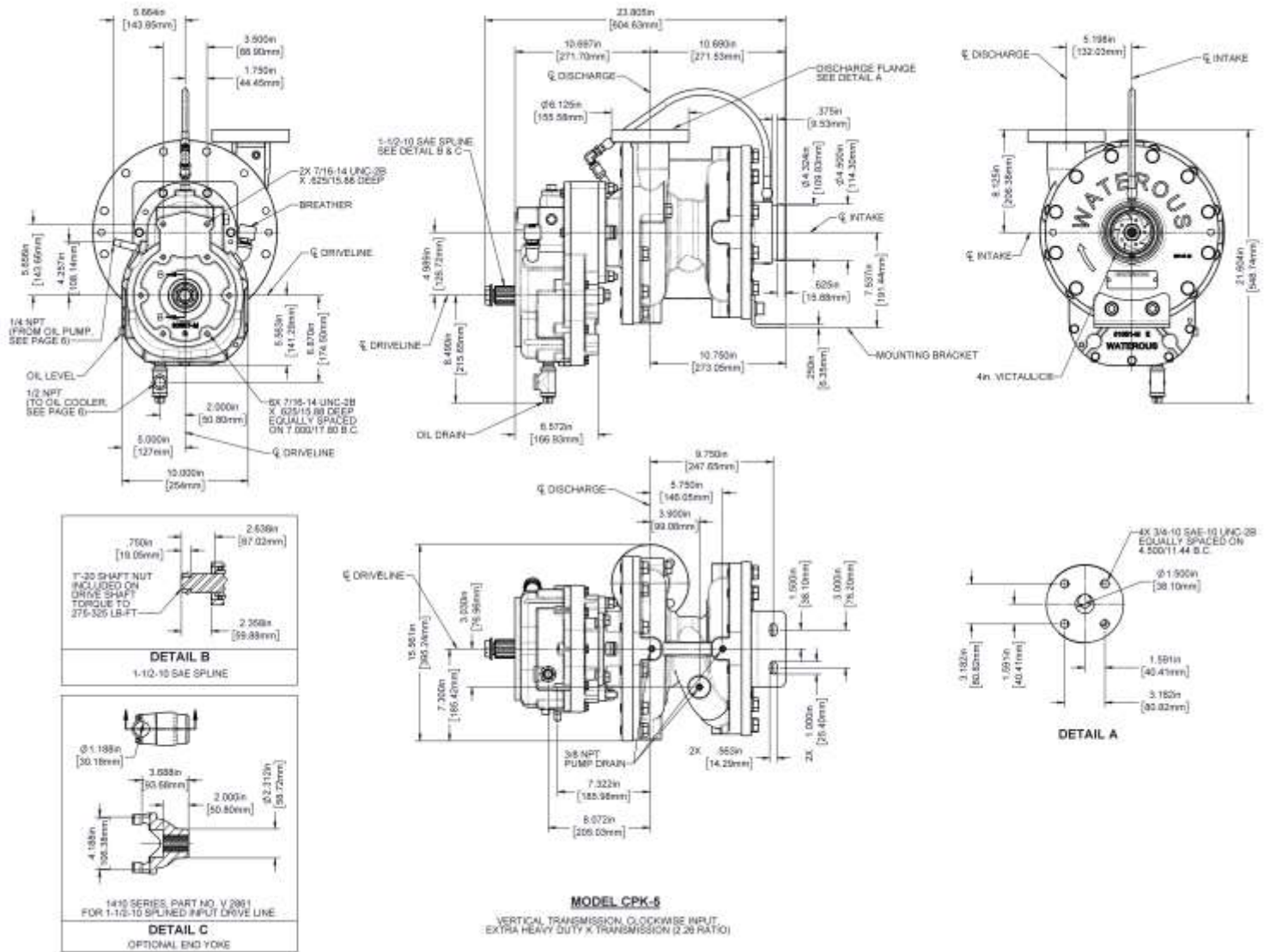

Oil Pump and Cooler Mounting

Figure 4 shows mounting locations and connection points for the oil pump and cooler that is used on the CPK-5.

NOTE: Before installation, make sure your pump has the right rotation as compared to the driveshaft rotation (see dimensional drawings for correct rotation configurations).

Figure 4. Oil Pump and Cooler Mounting Diagram

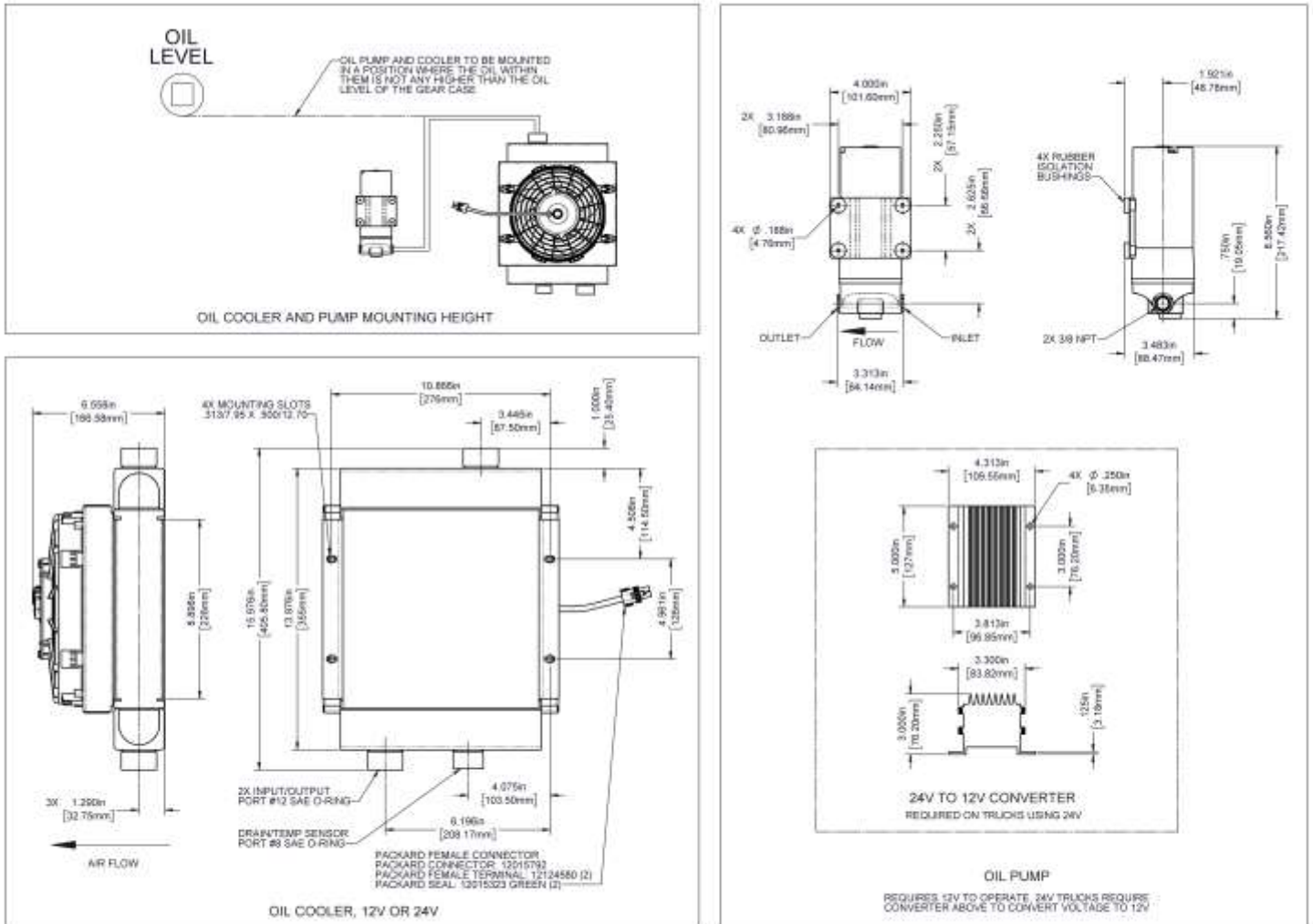

OIL PUMP AND COOLER

Figure 5. Oil Pump and Cooler Mounting Diagram Continued

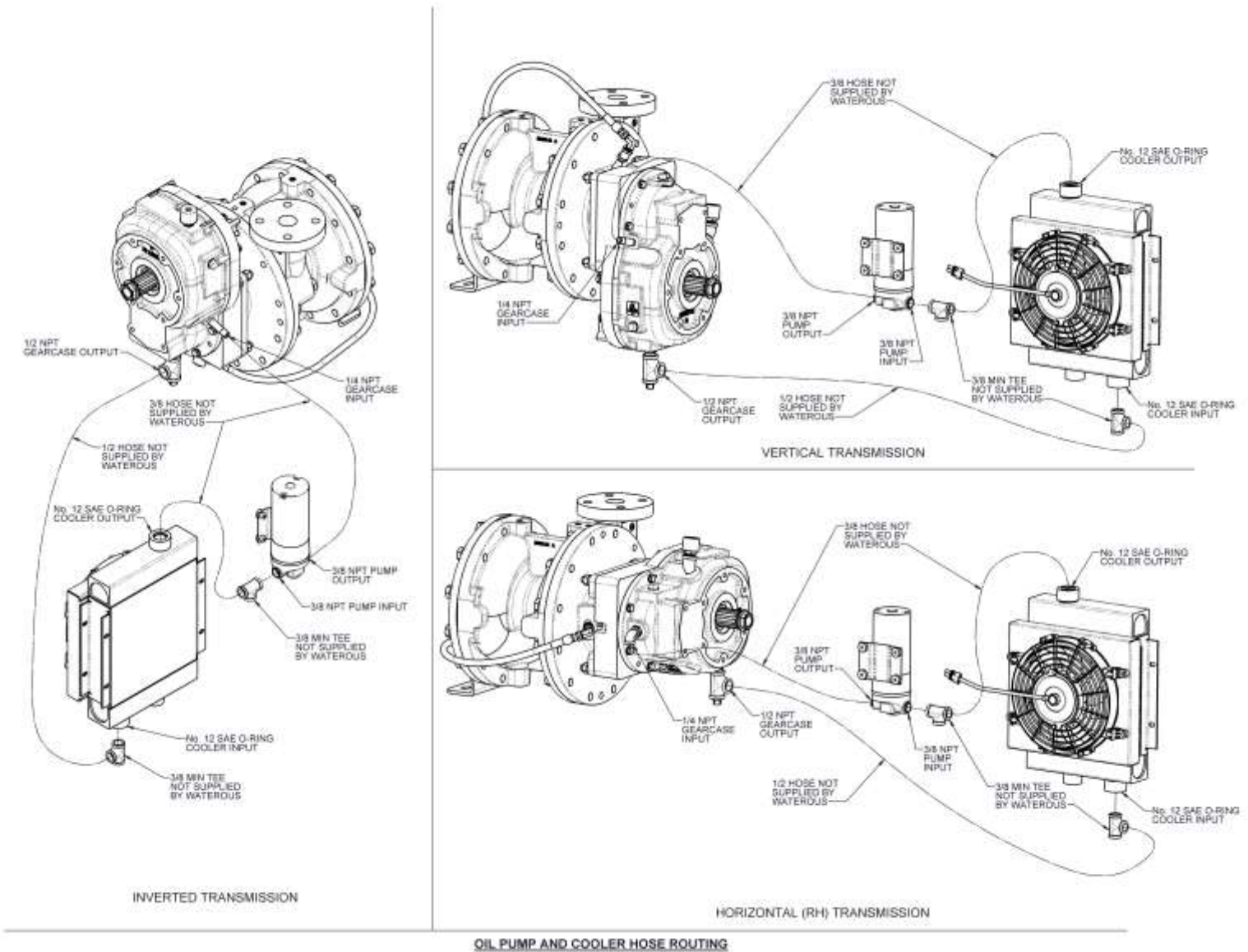

Final Checks

After the pump, accessories, piping and miscellaneous connections are completely installed, check the points listed below:

Lubrication

K Transmission

Gear lube spec: 75W-90 full synthetic.

Capacity:

Inverted mounting: 1.2 quarts

Horizontal mounting: 1.5 quarts

Vertical mounting: 1.6 quarts

(Capacity measurements are approximate and include the transmission, oil cooler, and oil pump. Hoses and fittings are not included. Adjust accordingly to application).

Oil fill procedure:

1. With oil level plug installed, fill transmission with 1.5 quarts of gear lube.
2. Run electric oil pump for 1 minute.
3. Stop oil pump.
4. Remove oil level plug.
5. Drain excess oil or add oil until a small stream of oil runs out oil level hole.
6. Install oil level plug.
7. Repeat steps 2-6 until no additional oil is required.

Testing

Perform the tests listed in F-1031, Section 1000, "*Centrifugal Fire Pump Principles of Operation, Inspection Tests and Troubleshooting Guide.*" During the running tests, monitor the smoothness of operation, listen for unusual noises and check for leaks.

CAUTION

Failure to properly lubricate the pump, transmission or primers may result in serious damage to the equipment.