

Medium Duty K Transmission Assy 83740

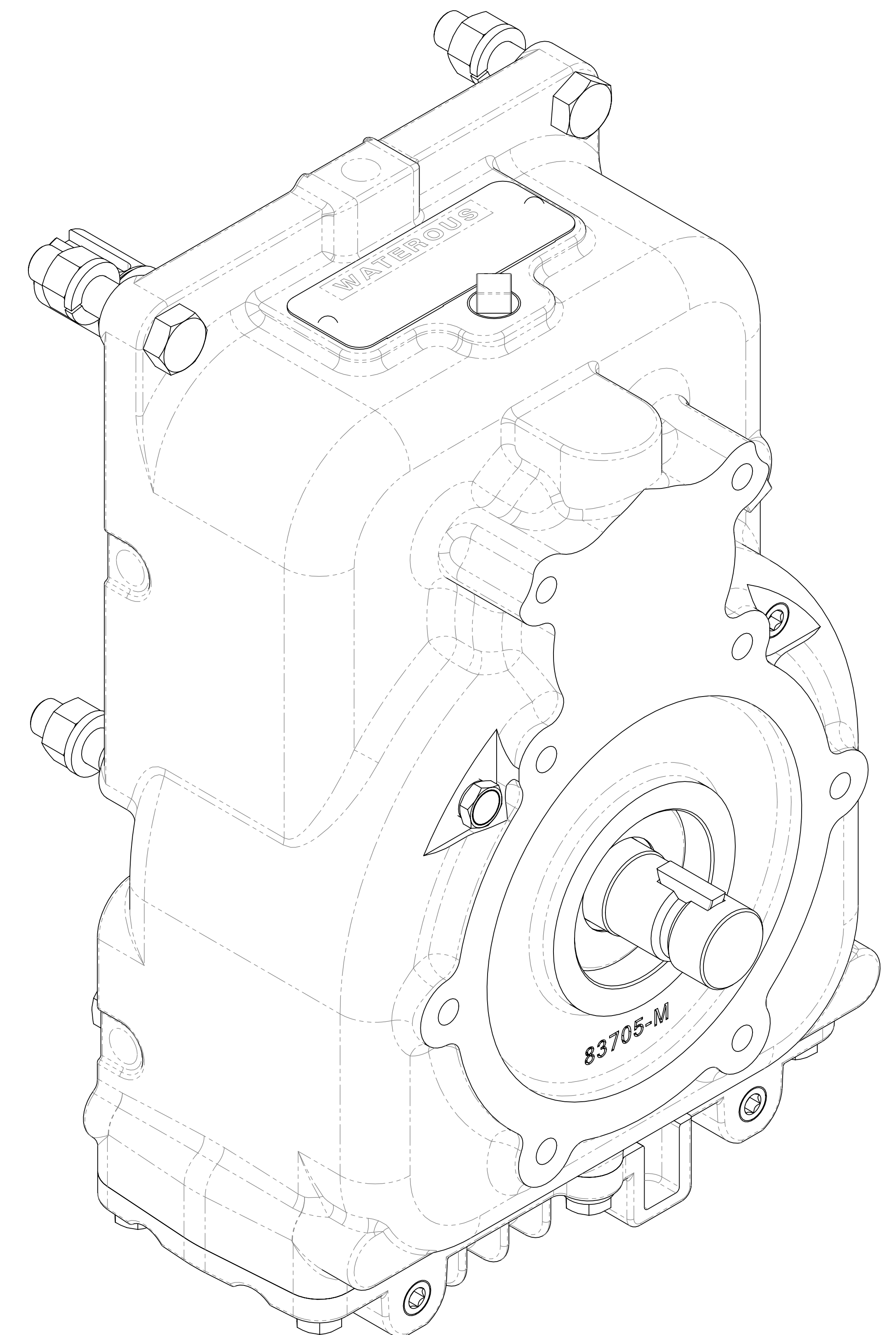

Pump Model	Impeller Shaft type	Extended Impeller Shaft	Input Type	See Sheet
CP-2, CP-4, CLR, CLV, CLS	One-Piece	No	Standard 1-1/8in. Keyed	2
		Yes	Hydraulic Flange Adapter	3
CP-2 Combination Pump	One-Piece	N/A	Standard 1-1/8in. Keyed	4
CP-3	Separable	N/A	SAE Class C Spline and Adatpter 72216	5
			Standard 1-1/8in. Keyed	6
			Hydraulic Flange Adapter	7
Oil Cooler Fittings - CP-4				8
Pump Mounting Positions - Oil Level, Breather, Drain, and Vent locations				9-10

Ref No.	Description
T1	Gear-Driven
T2	Gear-Drive
T3	Case-Transmission
T4	Pan-Oil, Cooler
T5	Housing-Bearing
T6	Cover-Bearing
T7	Gasket-Molded
T8	Shaft-Drive
T9	Bearing, Ball, Single Row, 30 x 72 x 19 mm
T10	Spacer-Bearing
T11	O-Ring, 4-3/8 x 4-5/8 in
T12	O-Ring, 3-1/4 x 3-1/2 in
T13	Seal-Oil, 1-3/16 x 2-7/16 in
T14	Seal-Oil, 1-3/16 x 1-11/16 in
T15	Ring-Retaining, External, 1-3/16 in Shaft Dia
T16	Key-Woodruff, 5/16 x 1 in
T17	Washer-Plain, 3/4 in
T18	Locknut-Flex Top, Thin, 3/4-16
T19	Key-Pinion Gear
T24	Screw-Drive, #6 x 1/4 in
T25	Screw-Hex Hd, 3/8-16 x 1 in
T26	Washer-Lock, 3/8 in
T27	Screw-Hex Hd, 1/2-13 x 2-1/4 in
T28	Stud-Coarse, 1/2-13 x 2-1/4 in
T29	Washer-Lock, 1/2 in
T30	Nut-Hex, 1/2-13
T41	Plate-Serial
34	Plug-Pipe, Headless, 1/4 NPT

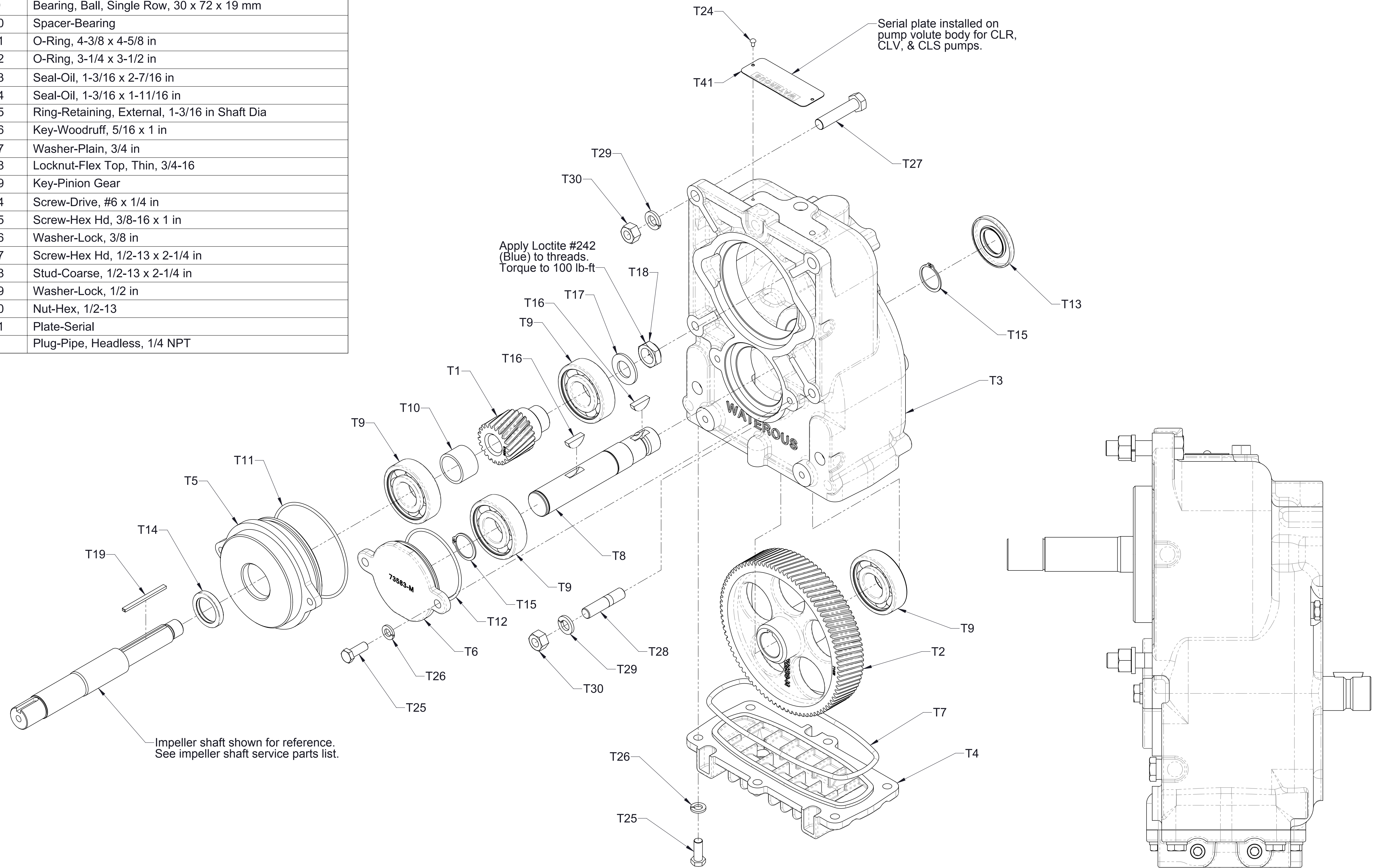

Transmission Assembly
One Piece Impeller Shaft w/o Extension, 1-1/8in. Keyed Input
CP-2, CP-4, CLR, CLV, CLS

Ref No.	Description
T1	Gear-Driven
T2	Gear-Drive
T3	Case-Transmission
T4	Pan-Oil, Cooler
T5	Housing-Bearing
T6	Cover-Bearing
T7	Gasket-Molded
T8	Shaft-Drive, Hydraulic
T9	Bearing, Ball, Single Row, 30 x 72 x 19 mm
T10	Spacer-Bearing
T11	O-Ring, 4-3/8 x 4-5/8 in
T12	O-Ring, 3-1/4 x 3-1/2 in
T13	Seal-Oil, 1-5/8 x 2-7/16 in
T14	Seal-Oil, 1-3/16 x 1-11/16 in
T15	Ring-Retaining, External, 1-3/16 in Shaft Dia
T17	Washer-Plain, 3/4 in
T18	Locknut-Flex Top, Thin, 3/4-16
T19	Key-Pinion Gear
T24	Screw-Drive, #6 x 1/4 in
T25	Screw-Hex Hd, 3/8-16 x 1 in
T26	Washer-Lock, 3/8 in
T27	Screw-Hex Hd, 1/2-13 x 2-1/4 in
T28	Stud-Coarse, 1/2-13 x 2-1/4 in
T29	Washer-Lock, 1/2 in
T30	Nut-Hex, 1/2-13
T31	Bushing-Adapter
T32	Adapter-Case Gear, Class C, Hyd Motor
T33	Screw-Cap, Hex Soc Hd, 7/16-14 x 1-1/4 in
T41	Plate-Serial
T48	Key-Square, 5/16 x 2-5/16 in

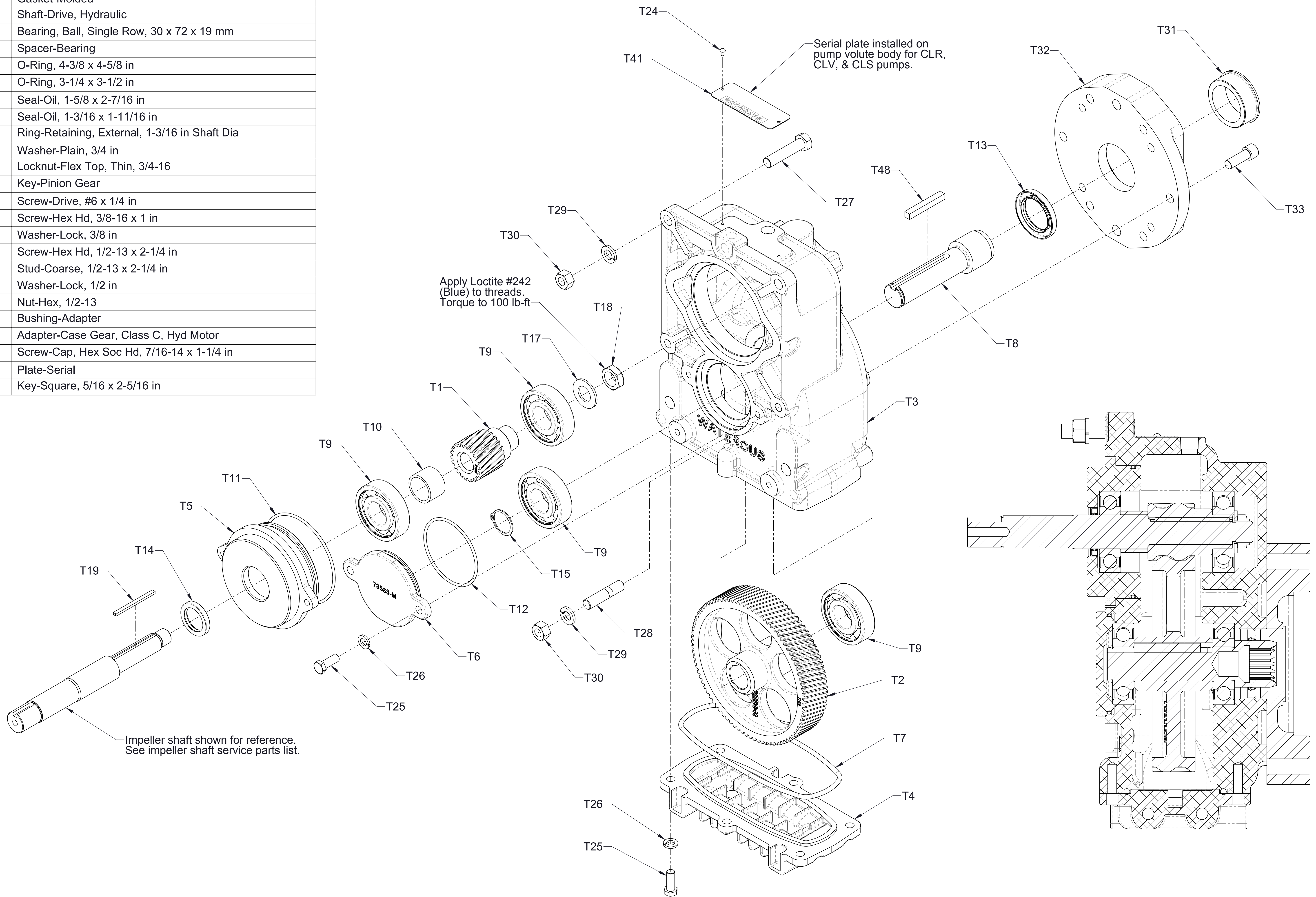

**Transmission Assembly
One Piece Impeller Shaft w/o Extension, SAE Class C Hydraulic Adapter
CP-2, CP-4, CLR, CLV, CLS**

Ref No.	Description
T1	Gear-Driven
T2	Gear-Drive
T3	Case-Transmission
T4	Pan-Oil, Cooler
T5	Housing-Bearing
T6	Cover-Bearing
T7	Gasket-Molded
T8	Shaft-Drive
T9	Bearing, Ball, Single Row, 30 x 72 x 19 mm
T10	Spacer-Bearing
T11	O-Ring, 4-3/8 x 4-5/8 in
T12	Gasket-Bearing, Cover
T13	Seal-Oil, 1-3/16 x 2-7/16 in
T14	Seal-Oil, 1-3/16 x 1-11/16 in
T16	Key-Woodruff, 5/16 x 1 in
T19	Key-Square, 1/4 x 1-1/2 in
T24	Screw-Drive, #6 x 1/4 in
T25	Screw-Hex Hd, 3/8-16 x 1 in
T26	Washer-Lock, 3/8 in
T27	Screw-Hex Hd, 1/2-13 x 2-1/4 in
T28	Stud-Coarse, 1/2-13 x 2-1/4 in
T29	Washer-Lock, 1/2 in
T30	Nut-Hex, 1/2-13
T35	Spacer-Bearing
T36	Bearing, Spherical Roller, Single Row, 30 x 72 x 19 mm
T37	Seal-Oil, 1-1/16 x 2 in
T38	Nut-Lock, Bearing, N06
T39	Washer-Lock, Bearing, W06
T41	Plate-Serial
T48	Key-Square, 5/16 x 2-5/16 in

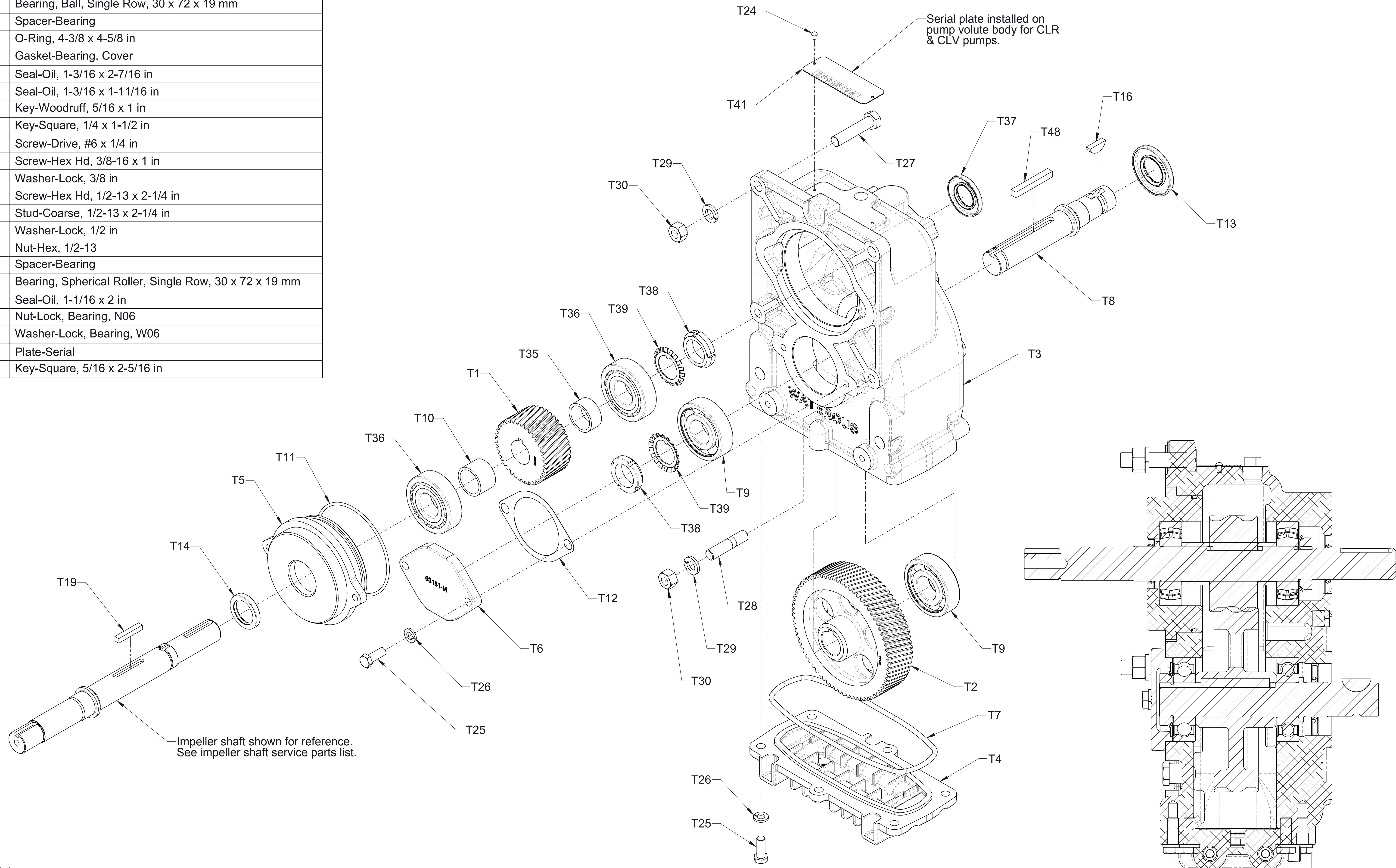

Note:
1. Belt and pulley may not have been furnished by Waterous

**Transmission Assembly
One Piece Impeller Shaft with Extension, 1-1/8in. Keyed Input
CP-2, CLR, CLV**

Ref No.	Description
T1	Gear-Driven
T2	Gear-Drive
T3	Case-Transmission
T4	Pan-Oil, Cooler
T5	Housing-Bearing
T6	Cover-Bearing
T7	Gasket-Molded
T8	Shaft-Drive, Hydraulic
T9	Bearing, Ball, Single Row, 30 x 72 x 19 mm
T10	Spacer-Bearing
T11	O-Ring, 4-3/8 x 4-5/8 in
T12	O-Ring, 3-1/4 x 3-1/2 in
T13	Seal-Oil, 1-5/8 x 2-7/16 in
T14	Seal-Oil, 1-3/16 x 1-11/16 in
T15	Ring-Retaining, External, 1-3/16 in Shaft Dia
T17	Washer-Plain, 3/4 in
T18	Locknut-Flex Top, Thin, 3/4-16
T19	Key-Pinion Gear
T24	Screw-Drive, #6 x 1/4 in
T25	Screw-Hex Hd, 3/8-16 x 1 in
T26	Washer-Lock, 3/8 in
T27	Screw-Hex Hd, 1/2-13 x 2-1/4 in
T28	Stud-Coarse, 1/2-13 x 2-1/4 in
T29	Washer-Lock, 1/2 in
T30	Nut-Hex, 1/2-13
T31	Bushing-Adapter
T41	Plate-Serial
T48	Key-Square, 5/16 x 2-5/16 in
T99	Adapter
T100	Screw-Hex Hd, 3/8-16 X 1-1/4 in
T101	Washer-Lock, 7/16 in
T102	Screw-Hex Hd, 7/16-14 x 1 in

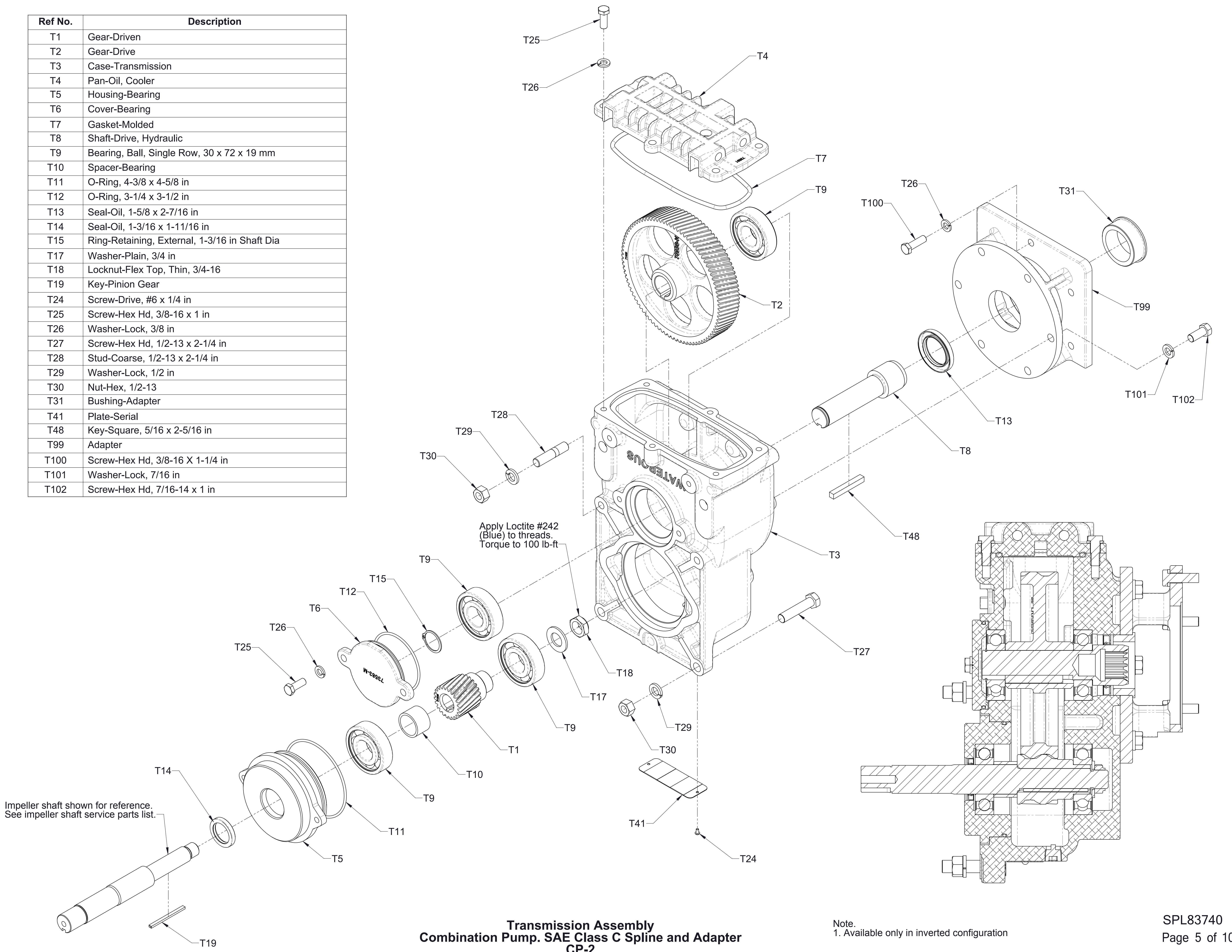

**Transmission Assembly
Combination Pump. SAE Class C Spline and Adapter
CP-2**

Note.
1. Available only in inverted configuration

Ref No.	Description
T1	Gear-Driven
T2	Gear-Drive
T3	Case-Transmission
T4	Pan-Oil, Cooler
T5	Housing-Bearing
T6	Cover-Bearing
T7	Gasket-Molded
T8	Shaft-Drive
T9	Bearing, Ball, Single Row, 30 x 72 x 19 mm
T10	Spacer-Bearing
T11	O-Ring, 4-3/8 x 4-5/8 in
T12	O-Ring, 3-1/4 x 3-1/2 in
T13	Seal-Oil, 1-3/16 x 2-7/16 in
T14	Seal-Oil, 1-1/2 x 2-1/2 in
T15	Ring-Retaining, External, 1-3/16 in Shaft Dia
T16	Key-Woodruff, 5/16 x 1 in
T17	Washer-Plain, 3/4 in
T18	Locknut-Flex Top, Thin, 3/4-16
T19	Key-Pinion Gear
T24	Screw-Drive, #6 x 1/4 in
T25	Screw-Hex Hd, 3/8-16 x 1 in
T26	Washer-Lock, 3/8 in
T27	Screw-Hex Hd, 1/2-13 x 2-1/4 in
T28	Stud-Coarse, 1/2-13 x 2-1/4 in
T29	Washer-Lock, 1/2 in
T30	Nut-Hex, 1/2-13
T34	Shaft-Driven
T41	Plate-Serial

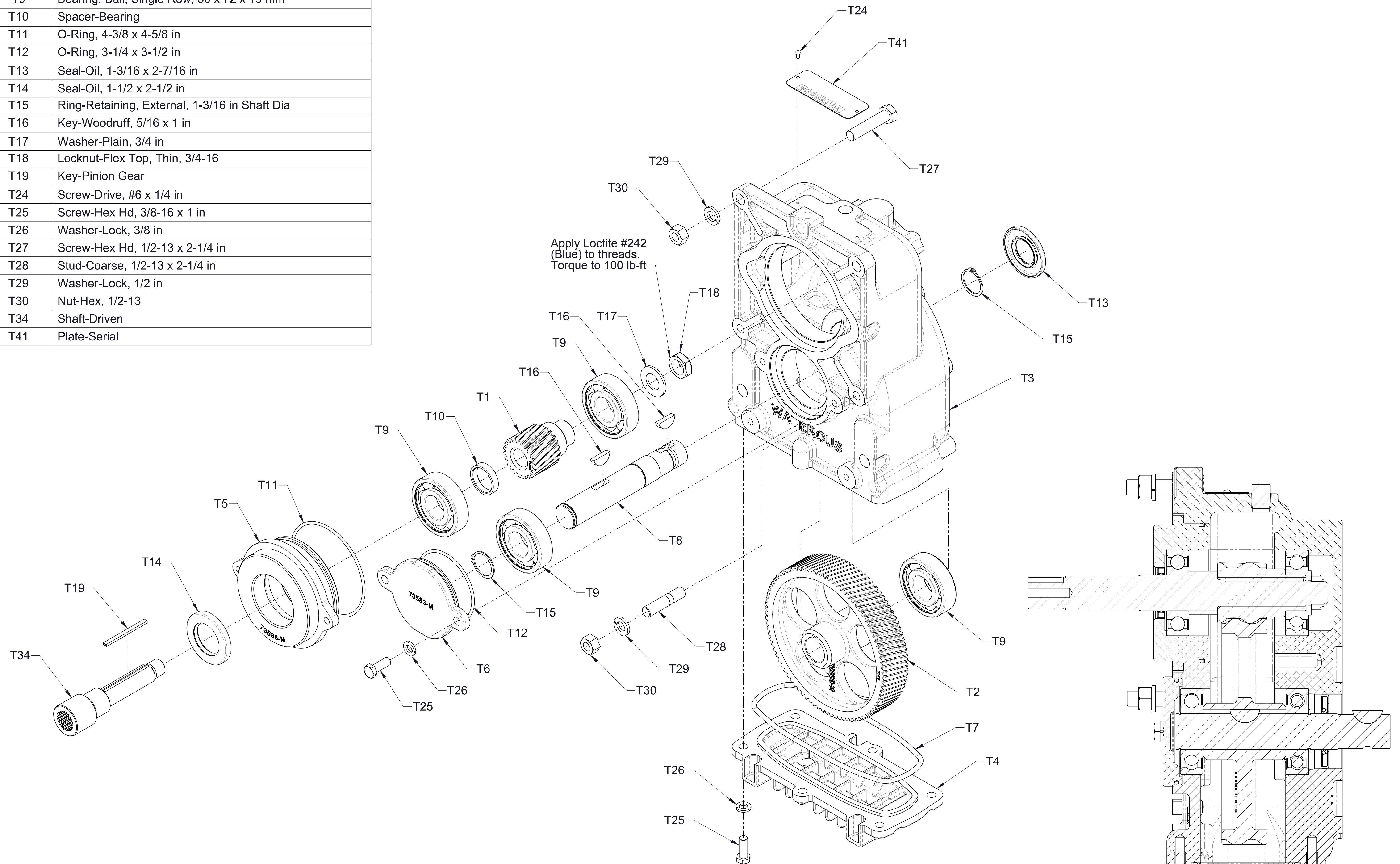

**Transmission Assembly
Separable Impeller Shaft, 1-1/8in. Keyed Input
CP-3**

Ref No.	Description
T1	Gear-Driven
T2	Gear-Drive
T3	Case-Transmission
T4	Pan-Oil, Cooler
T5	Housing-Bearing
T6	Cover-Bearing
T7	Gasket-Molded
T8	Shaft-Drive, Hydraulic
T9	Bearing, Ball, Single Row, 30 x 72 x 19 mm
T10	Spacer-Bearing
T11	O-Ring, 4-3/8 x 4-5/8 in
T12	O-Ring, 3-1/4 x 3-1/2 in
T13	Seal-Oil, 1-5/8 x 2-7/16 in
T14	Seal-Oil, 1-1/2 x 2-1/2 in
T15	Ring-Retaining, External, 1-3/16 in Shaft Dia
T17	Washer-Plain, 3/4 in
T18	Locknut-Flex Top, Thin, 3/4-16
T19	Key-Pinion Gear
T24	Screw-Drive, #6 x 1/4 in
T25	Screw-Hex Hd, 3/8-16 x 1 in
T26	Washer-Lock, 3/8 in
T27	Screw-Hex Hd, 1/2-13 x 2-1/4 in
T28	Stud-Coarse, 1/2-13 x 2-1/4 in
T29	Washer-Lock, 1/2 in
T30	Nut-Hex, 1/2-13
T31	Bushing-Adapter
T32	Adapter-Case Gear, Class C, Hyd Motor
T33	Screw-Cap, Hex Soc Hd, 7/16-14 x 1-1/4 in
T34	Shaft-Driven
T41	Plate-Serial
T48	Key-Square, 5/16 x 2-5/16 in

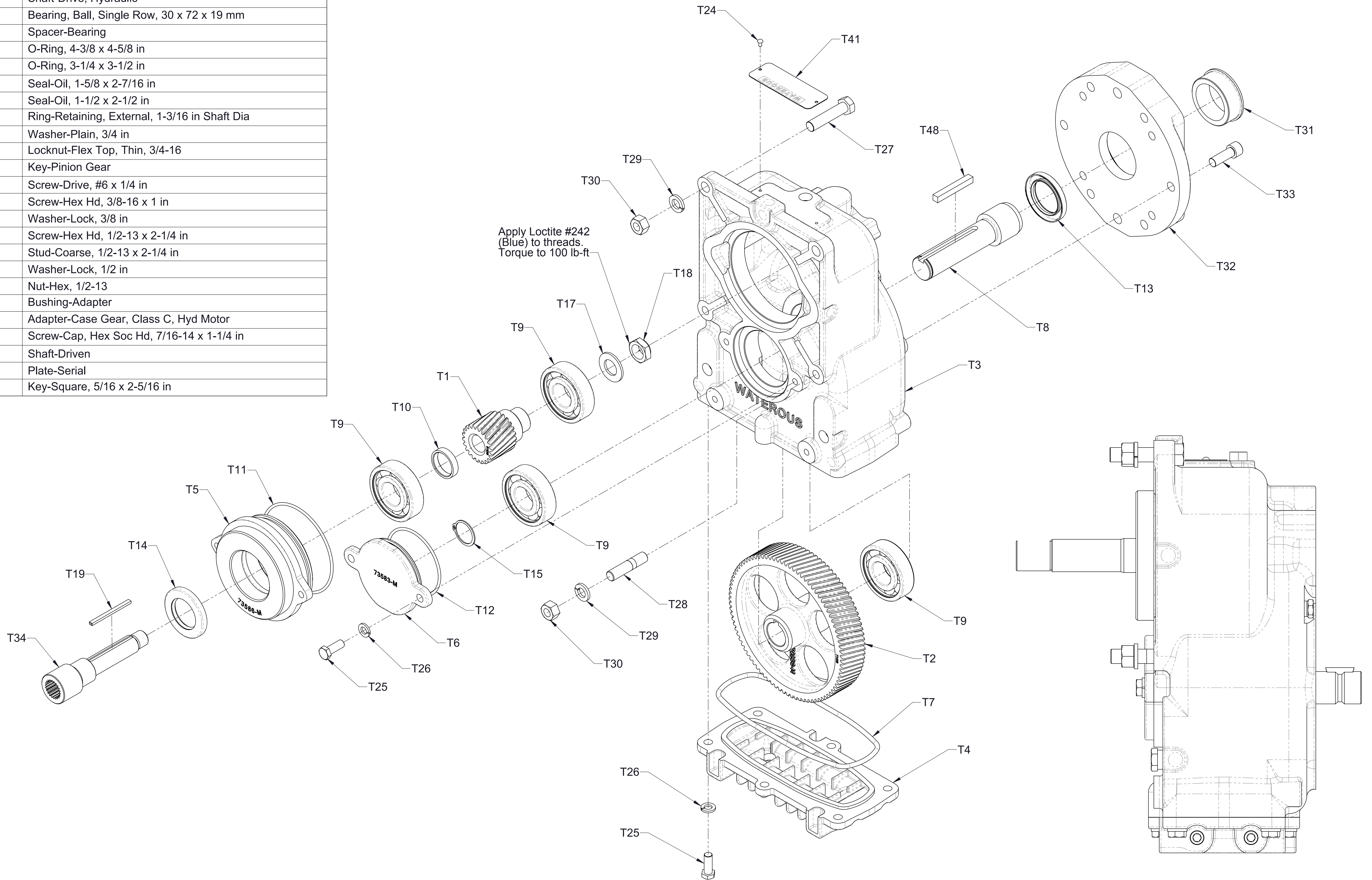

Transmission Assembly
Separable Impeller Shaft, 1-1/8in. SAE Class C Hydraulic Adapter
CP-3

Ref No.	Description
T105	Tee-Street, 1/4 NPT
T106	Bushing-Reducing, Pipe, 3/8 x 1/4 NPT
T107	Elbow-Adapter, Union, 90deg, 1/4 NPT
T108	Hose, High Pressure, 1/4 NPT x 23 in
T109	Hose, High Pressure, 1/4 NPT x 31 in

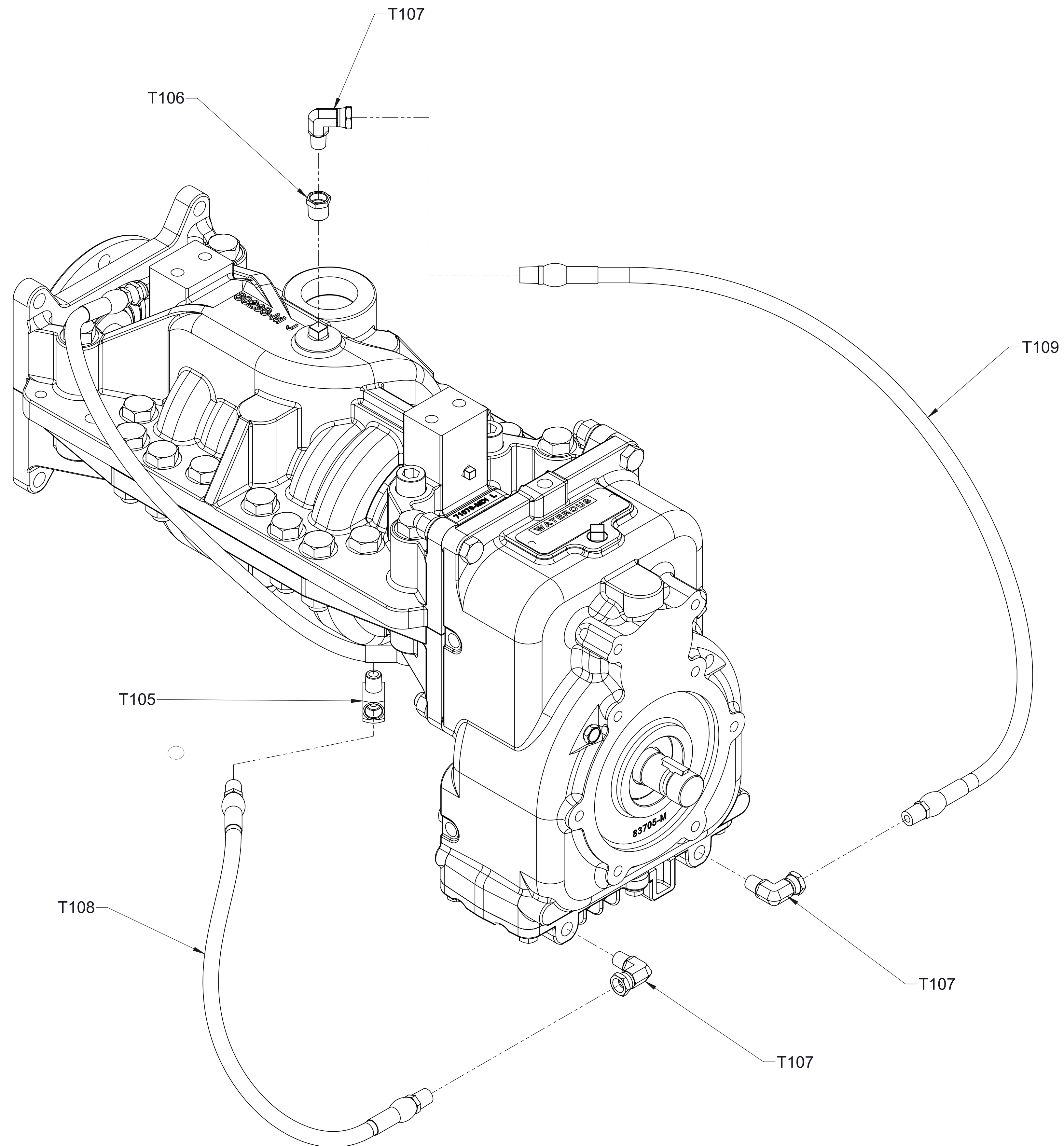

Note:
 1. Route hoses so they drain through the transmission or pump. Draining is not required when pump is mounted with a horizontal or inverted discharge

Ref No.	Description
T20	Breather, 1/4 NPT
T21	Plug-Level, Oil, 3/8
T22	Plug-Drain, Magnetic, 3/8, Headless
T23	Plug-Pipe, Square Hd, 3/8 NPT
T40	Plug-Pipe, Headless, 1/4 NPT
T42	Plug-Pipe, Headless, 1/4 NPT

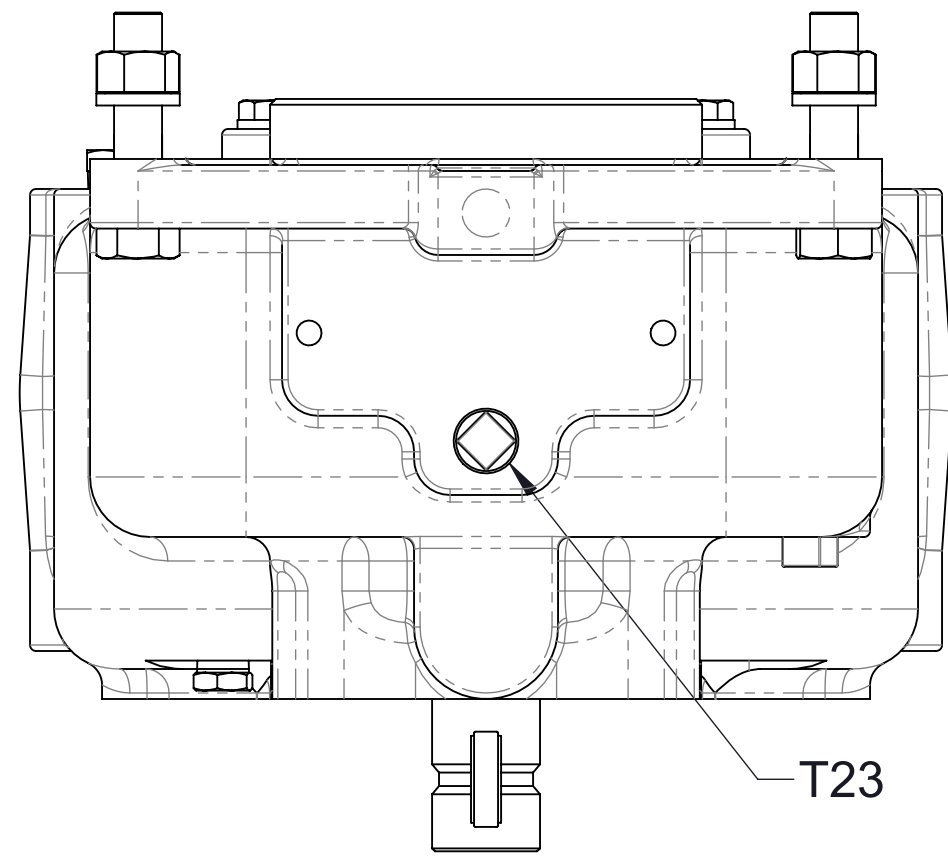

T20 (CCW Input Rotation)
T40 (CW Input Rotation)

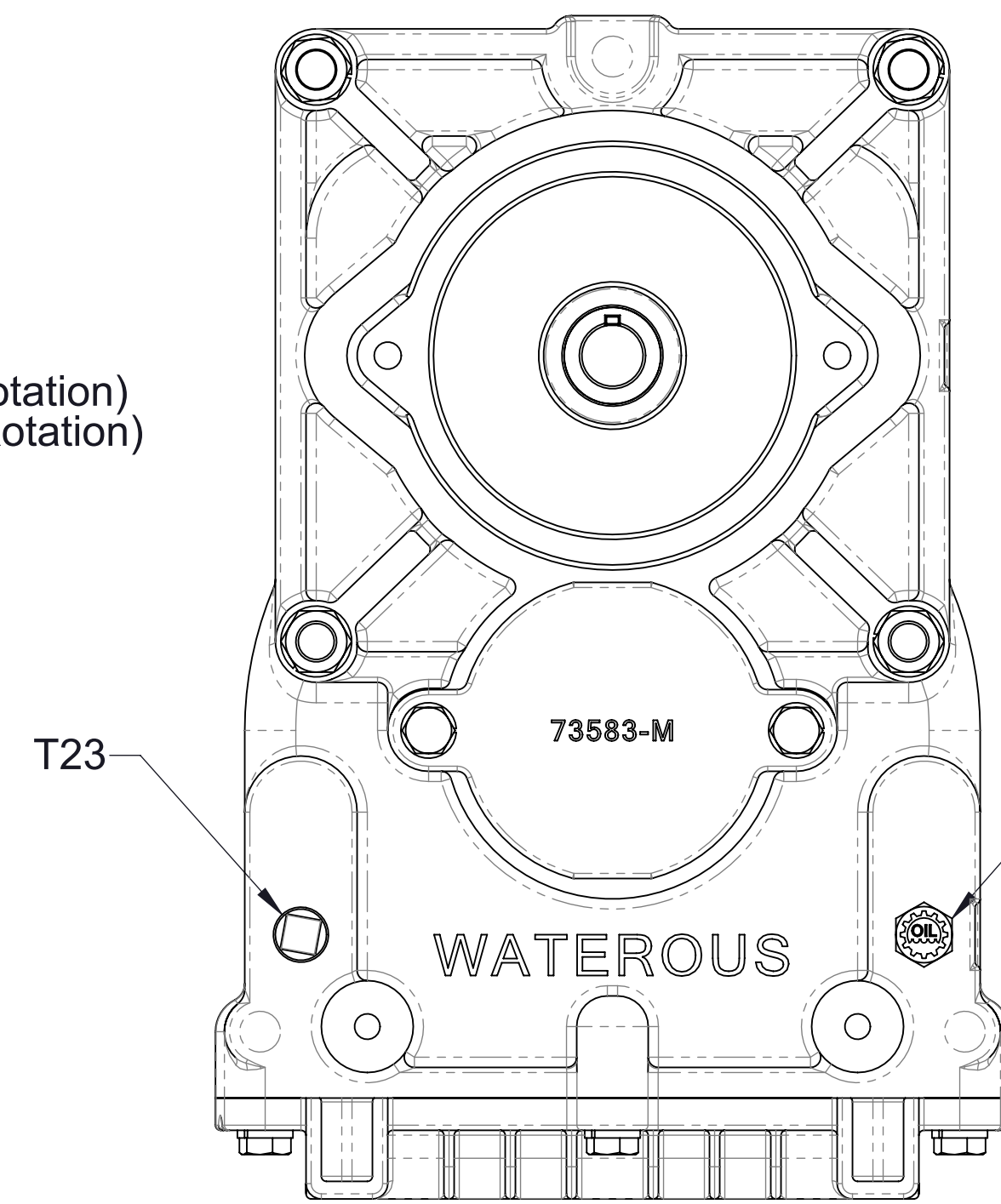
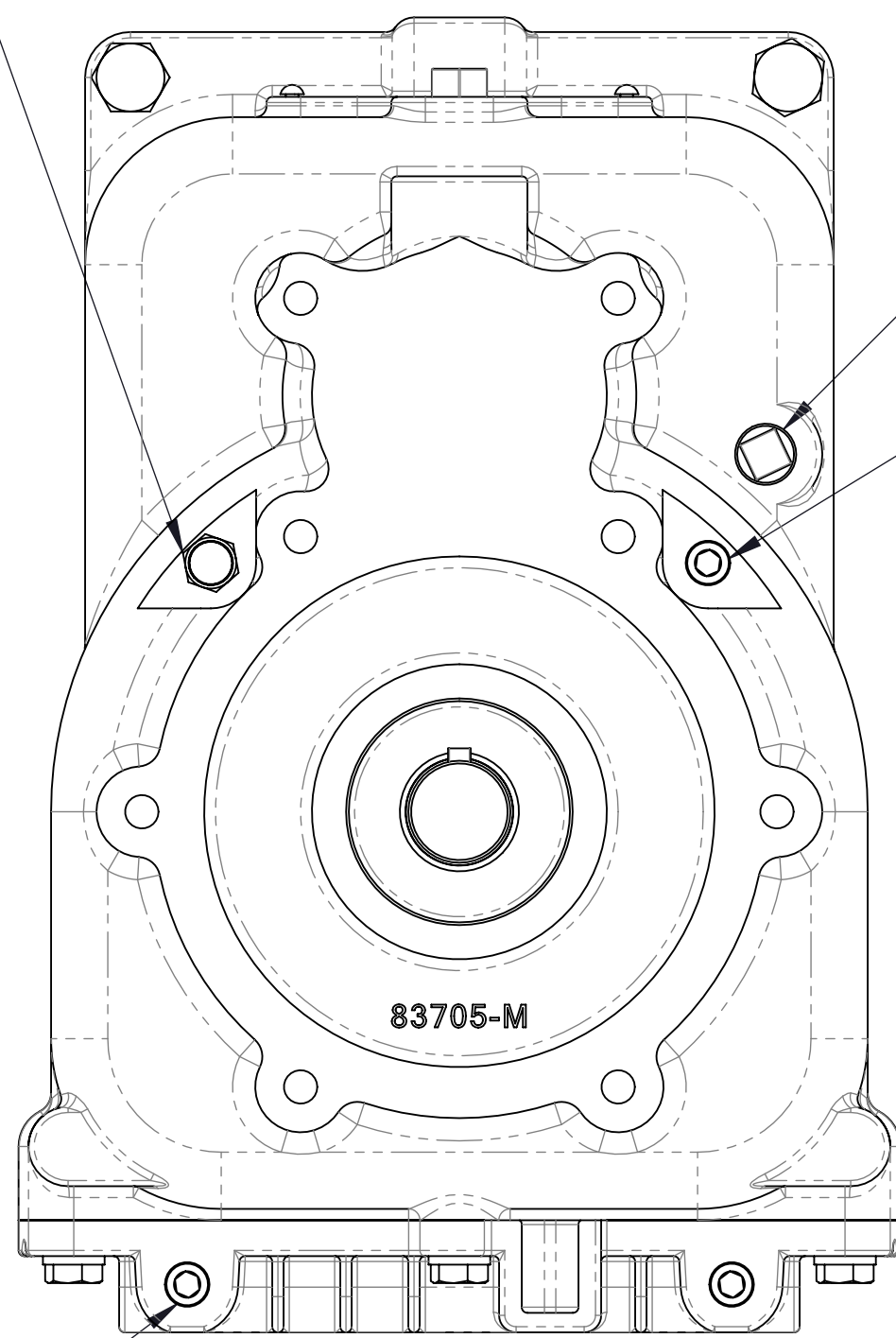

T42

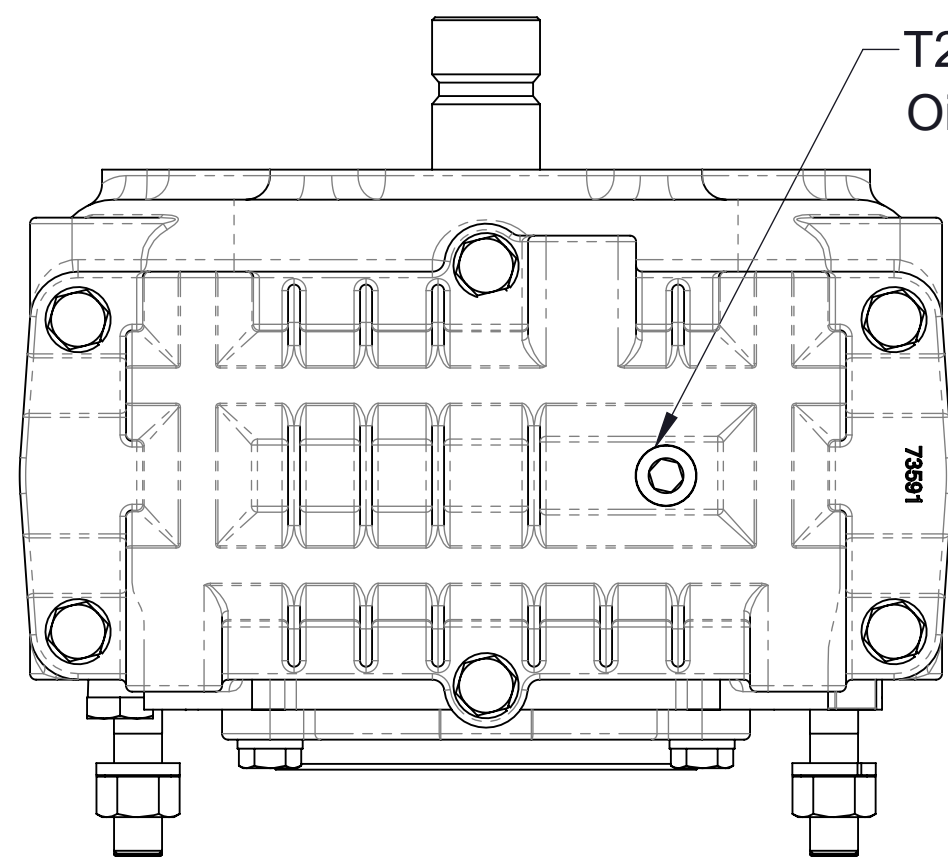

Vertical

Ref No.	Description
T20	Breather, 1/4 NPT
T21	Plug-Level, Oil, 3/8
T22	Plug-Drain, Magnetic, 3/8, Headless
T23	Plug-Pipe, Square Hd, 3/8 NPT
T40	Plug-Pipe, Headless, 1/4 NPT
T42	Plug-Pipe, Headless, 1/4 NPT
T103	Bushing-Reducing, 3/8 MNPT x 1/4 FNPT
T104	Elbow-Street, 90°, 1/4 NPT

Note transmission pan orientation

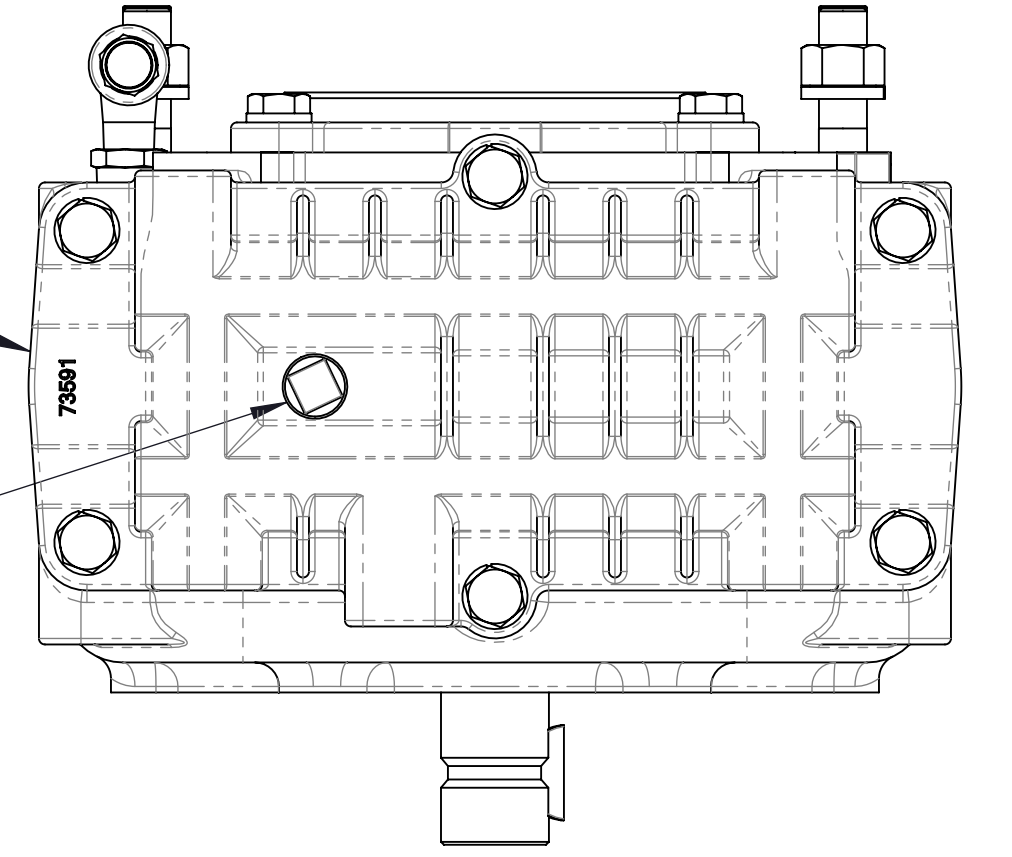

T42

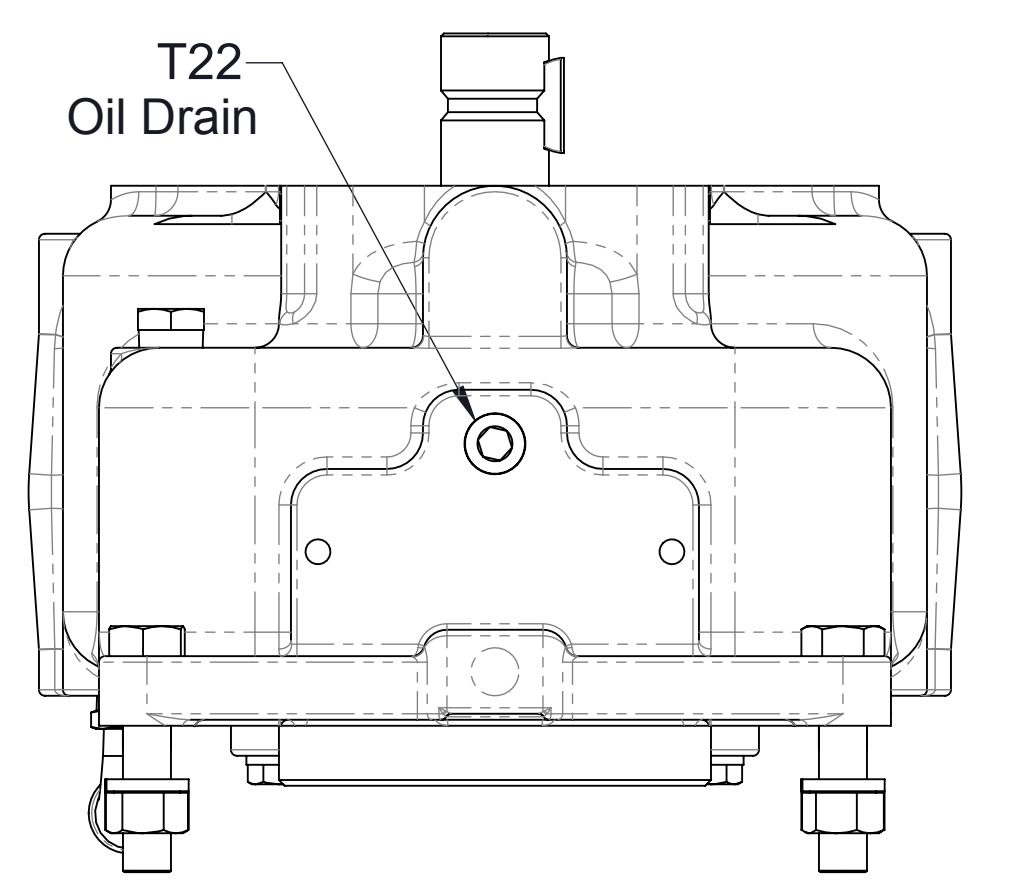
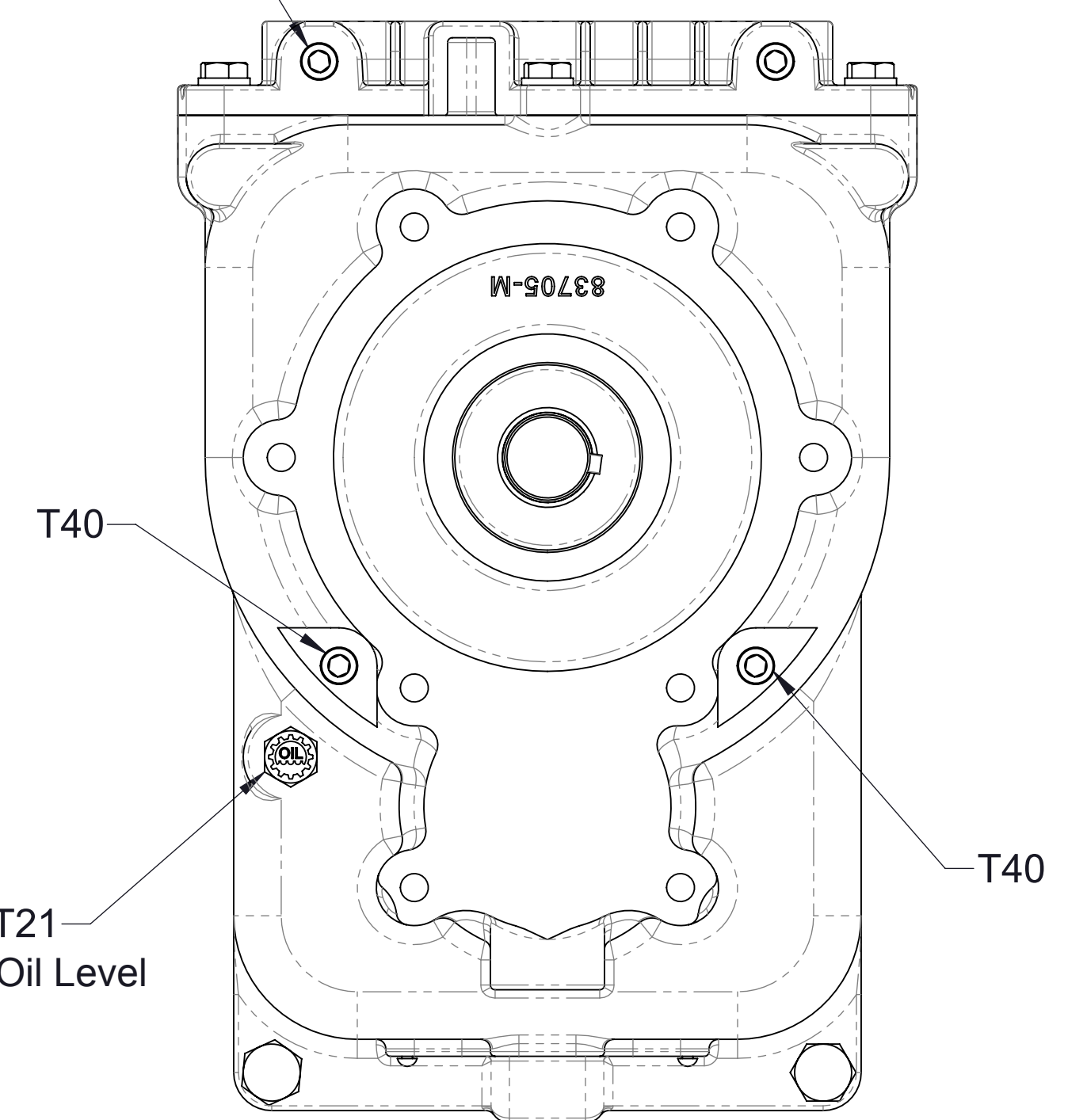
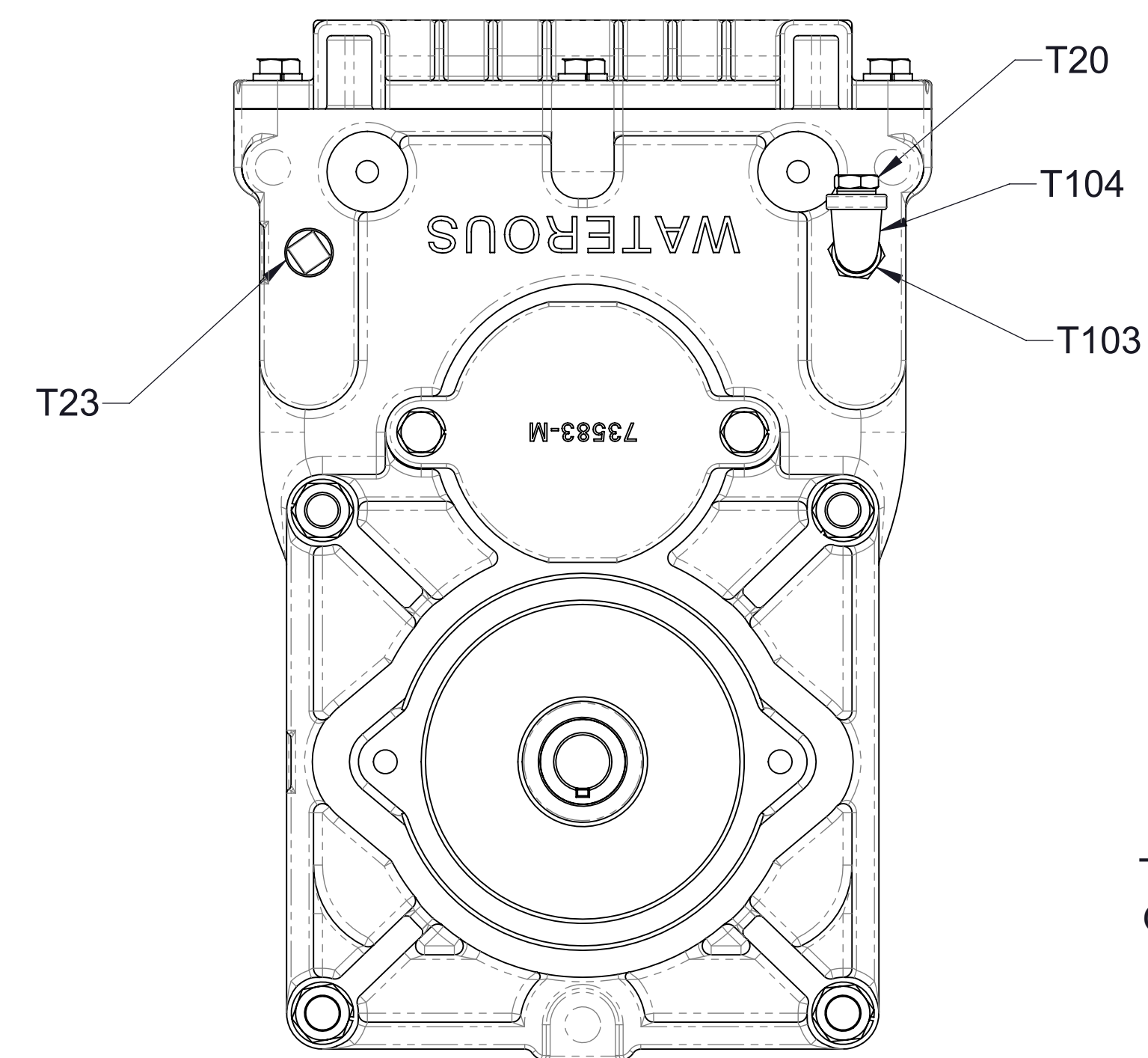

Inverted

Breather, Drain, Oil Level, and Plug Locations
Vertical and Inverted Mounting Positions

Ref No.	Description
T20	Breather, 1/4 NPT
T21	Plug-Level, Oil, 3/8
T22	Plug-Drain, Magnetic, 3/8, Headless
T23	Plug-Pipe, Square Hd, 3/8 NPT
T40	Plug-Pipe, Headless, 1/4 NPT
T42	Plug-Pipe, Headless, 1/4 NPT
T103	Bushing-Reducing, 3/8 MNPT x 1/4 FNPT
T104	Elbow-Street, 90°, 1/4 NPT

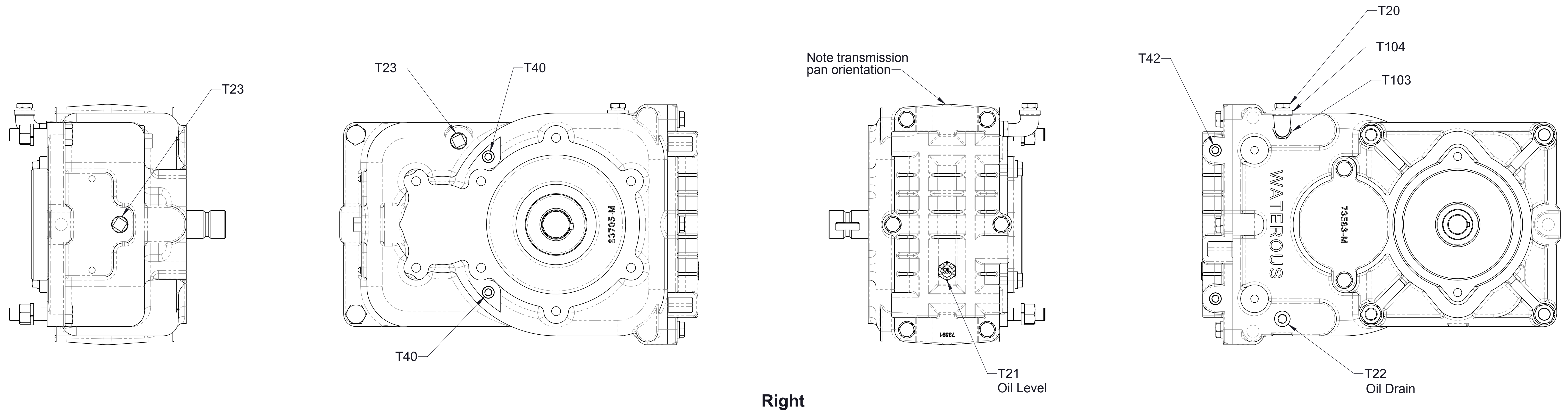

Ref No.	Description
T20	Breather, 1/4 NPT
T21	Plug-Level, Oil, 3/8
T22	Plug-Drain, Magnetic, 3/8, Headless
T23	Plug-Pipe, Square Hd, 3/8 NPT
T40	Plug-Pipe, Headless, 1/4 NPT
T42	Plug-Pipe, Headless, 1/4 NPT
T103	Bushing-Reducing, 3/8 MNPT x 1/4 FNPT
T104	Elbow-Street, 90°, 1/4 NPT

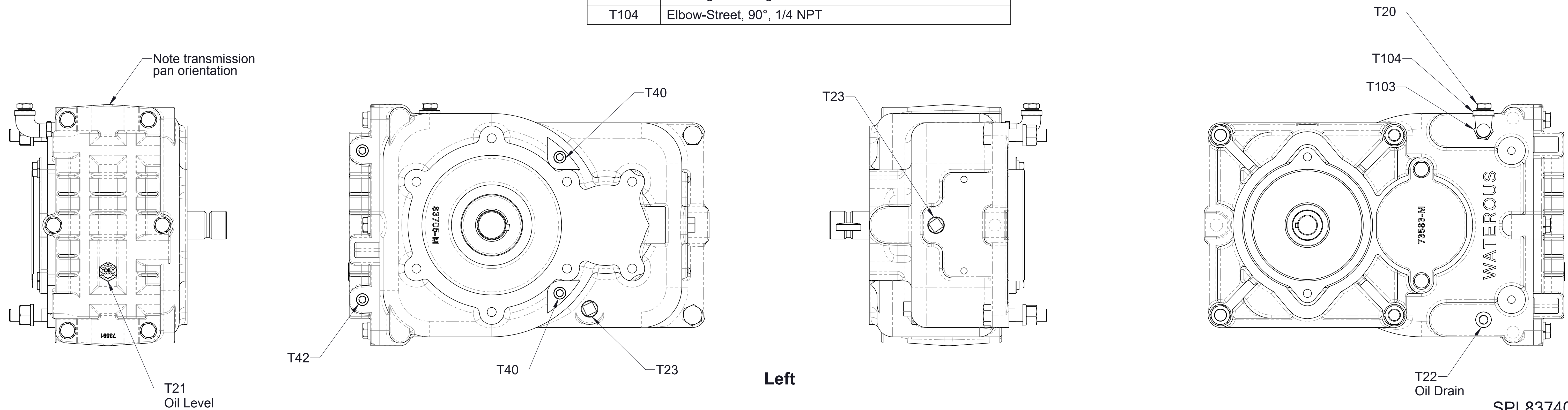

**Breather, Drain, Oil Level, and Plug Locations
Left and Right Mounting Positions**