

CP Series Centrifugal Fire Pumps

Operation and Maintenance

Form No.	Section	Issue Date	Rev. Date
F-1031	2113	09/16/94	7/6/18

Table of Contents

Safety Information	2, 3
Introduction.....	4
General Description	4
Components	4
Options	4
Operating Instructions	8
Pumping from Water Tank.....	8
Pumping from Hydrant or in Relay	9
Pumping from Draft	10, 11
Fire Hose Testing.....	12
Maintenance	12
Corrosion Protection.....	12
Optional Zinc Intake Screens	13
Optional Zinc Anodes.....	13
Pump Storage	13
Lubrication	13
Outboard Bearing (CP-3, CP-4)	13
Transfer Valve (CP-3)	13
Packing.....	14
Packing Removal	14
Packing Installation	15
Packing Adjustment	16
Vacuum Test	16
Overheat Protection Manager (OPM)-----	17

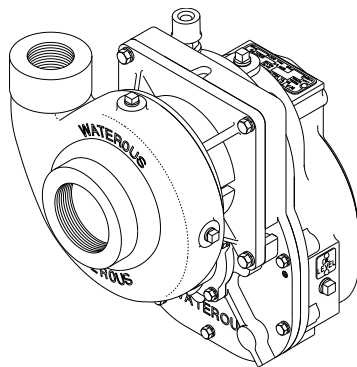

IL1595

Table of Figures

1. CP-1 Series Pump w/ K Series Transmission .. 5
2. CP-2 Series Pump w/ K Series Transmission .. 5
3. CP-2L Series Pump w/ K Series Transmission . 5
4. CP-3 Series Pump w/ K Series Transmission .. 6
5. CP-4 Series Pump w/ K Series Transmission ... 6
6. E-301-A, E-302-a (CPT-1, CPT-2)..... 7
7. Zinc Intake Screens



Read through the safety information and operating instructions carefully before using your Waterous Fire Pump.

WATEROUS

Fire Pumps – Since 1886

Visit us at www.waterousco.com

Safety Information



Read through the safety information and operating instructions carefully before using your Waterous Fire Pump.

WARNING

Death or serious personal injury might occur if proper operating procedures are not followed. The pump operator, as well as individuals connecting supply or discharge hoses to the apparatus must be familiar with these pump operating instructions as well as other operating instructions and manuals for the apparatus, water hydraulics and component limitation.

WARNING

Unexpected Truck Movement. May result in serious personal injury or death.

Failure to properly shift transmission in accordance to the transmission operating instructions may result in unexpected truck movement which may result in serious personal injury or death.

WARNING

Pressure Hazard. May result in personal injury.

Prior to connection or removal of hoses, caps or other closures with pump intake or pump discharge connections, relieve pressure by opening drains or bleeder valves. Bleeder valves should also be used while filling a hose connected to an intake with water.

WARNING

Discharge pressure change hazard. May cause serious personal injury to the hose line operator.

Changing the position of the transfer valve while the pump is operating may cause significant changes in the discharge pressure, which may result in serious personal injury to the hose line operator.

WARNING

Scalding Water Hazard. May result in serious burns.

When operating the pump, be sure to open at least one discharge valve slightly to prevent the pump from overheating. If the pump runs for a few minutes completely closed, it may heat the water enough to scald someone when the valve is opened. Overheating can damage the packing, seals and other pump parts. If the apparatus builder has installed a by-pass system or other provision designed to prevent overheating, opening a discharge valve may be unnecessary.

WARNING

Rotating Parts Hazard or Unexpected Truck Movement. May result in serious personal injury or death.

Stop the engine, set parking brake and chock the wheels before going under the truck to adjust packing or to check packing gland temperature.

WARNING

Packing Gland and Pump Body Temperature Hazard. May result in serious burns.

Heat is dissipated through the cross-section of the packing, transferring the heat to the packing gland and pump body.

Safety Information



Read through the safety information and operating instructions carefully before using your Waterous Fire Pump.



WARNING

Hose Testing Hazard. May result in serious personal injury.

Due to a potential for catastrophic hose failure during service testing of fire hose, it is vital that safety precautions be taken to prevent exposure of anyone to this danger. Fire pumps on fire department apparatus are not designed for and should not be used for service testing of fire hoses. Hose testing machines should be used for service testing of fire hoses.



WARNING

Pressure Hazard. May result in serious personal injury.

If a fire pump on a fire department apparatus is used for service testing of fire hoses, the procedures in NFPA 1962 **MUST be followed** including the use of a fire department gate valve with a ¼-inch (6 mm) hole drilled through the gate installed between the fire apparatus discharge outlet and the hose test layout to prevent a volume surge from the pump in the event a hose bursts during testing.



WARNING

Scalding Water Hazard. May result in serious burns.

If a fire pump on a fire department apparatus is used for service testing of fire hoses, pump discharge water must be circulated through a by-pass system or discharged through a slightly open discharge valve, or some other provision must be used to prevent overheating. If the pump runs for a few minutes without adequate flow through the pump, water may be heated enough to scald someone when a valve is opened.

Introduction

This instruction contains the information needed for operation and maintenance of CP Series centrifugal pumps. Since there are several types of transmissions available for these pumps, they are covered in separate instructions. E301-A and E302-A models are CP-1 and CP-2 pumps mounted on Kubota diesel engines from the factory. Any of the following instructions for CP-1 and CP-2 models apply to E301-A and E302-A models (respectively).

General Description

The CP series pumps are designed to provide a wide range of pressures and capacities and can be driven by truck transmission mounted power take-offs or other suitable drives. All CP pumps have an integral speed increasing transmission with proper gear ratio to provide required

impeller speeds at available input speeds, whether pumping from tank, draft or in relay operation. CP pumps may be operated independently, simultaneously or in series with the main pump on the apparatus.

Components

Body Assembly

This assembly includes the body, transfer and flap valves and related parts. The body and adapters are either cast iron or bronze.

Impeller Shaft Assembly

This assembly consists of bronze impeller(s) mounted on a stainless steel shaft with wear rings, packing or mechanical seal and related parts. The impellers are balanced and the impeller shaft is supported by ball bearings.

Mechanical Seals

Mechanical seals are standard on CP-1, CP-2, CP-2L and CP-3 pumps.

A mechanical seal consists of a flat, highly polished (lapped), spring-fed carbon ring that is sealed to and rotates with the impeller shaft. It presses against a highly polished (lapped), silicon carbide, stationary ring that is sealed in the pump body. This seals the shaft and prevents air from entering and water from leaving. A mechanical seal does not leak or drip water, even when pumping.

Packing

Waterous CP-1 and CP-2 pumps use a braided graphite fiber, with reinforced flexible graphite yarns and high purity graphite filament yarns that appear on the corners as well as throughout the body of the packing.

Waterous CP-4 pumps use a combination of Grafoil and braided graphite packing.

The square rings of packing are held in place by a split bronze gland which is fully removable and adjustable. Waterous packing materials, when installed correctly, provide optimum sealing characteristics, minimize shaft wear and eliminate repacking.

Options

Intake Screens

Zinc die cast screens are normally used in the intake fittings, with brass screens available optionally. Although the screens are chemically treated (coated) to inhibit corrosion, the water being pumped may still corrode the screens. Such corrosion is "sacrificial"; that is, it will help prevent corrosion in the rest of the pump the same way the magnesium anodes protect the metal parts of a water heater.

Anodes

As additional corrosion protection for iron body pumps, Waterous has available zinc anodes to fit any unused opening in the intake fitting. Anodes provide an additional sacrificial zinc surface to the water to supplement the zinc intake screens.

Overheat Protection Manager (OPM)

The Overheat Protection Manager (OPM) acts as a safety device by releasing hot water to the ground or back to the water tank from the discharge area of the pump.

Figure 1. CP-1 Series Pump with K Series Transmission

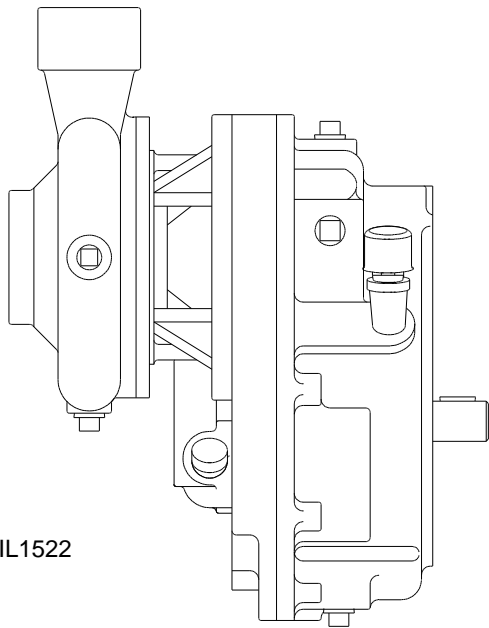

IL1522

Figure 2. CP-2 Series Pump with K Series Transmission

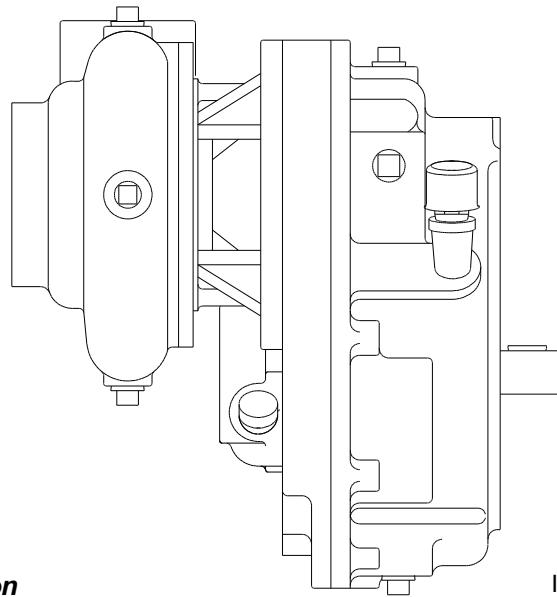

IL1523

Figure 3. CP-2L Series Pump with TA Series Transmission

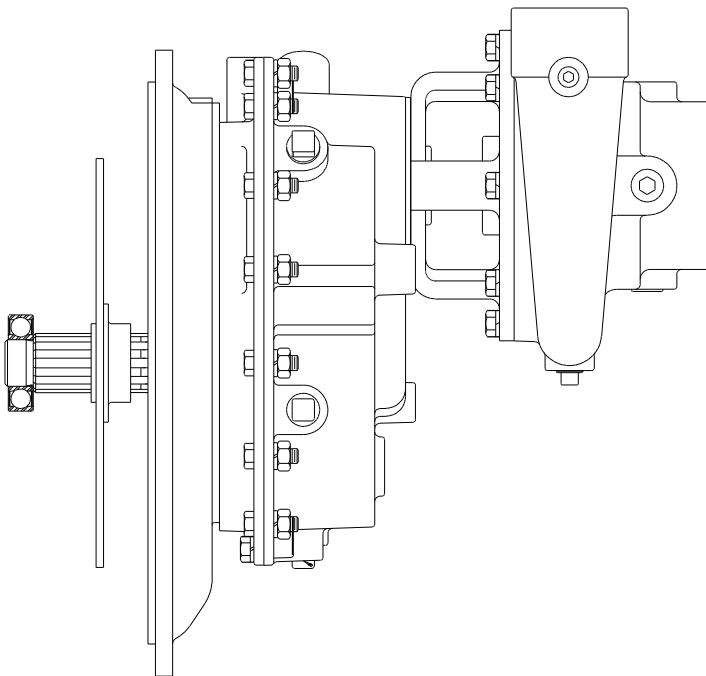
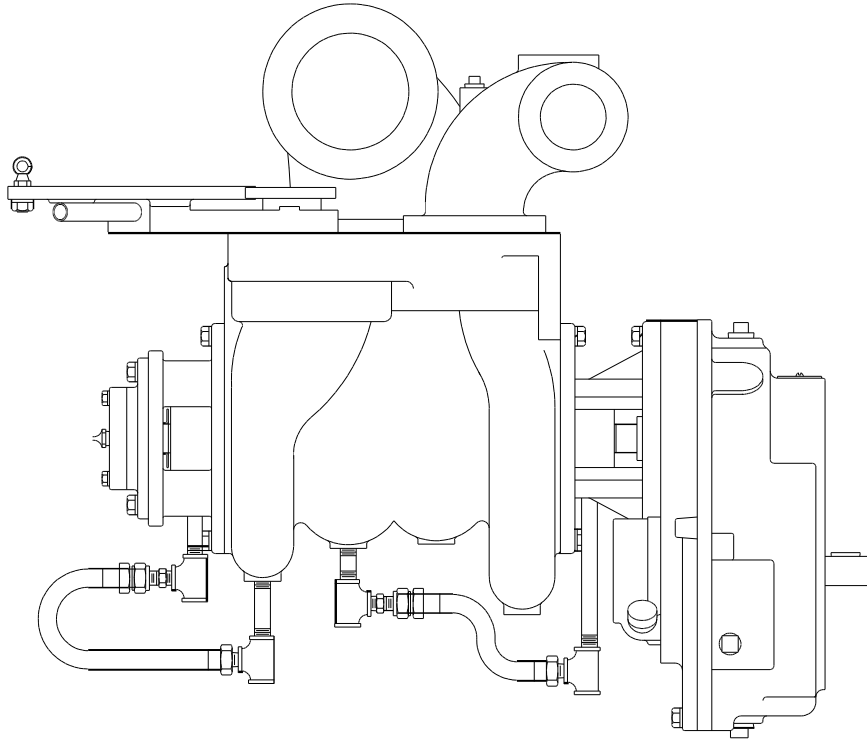
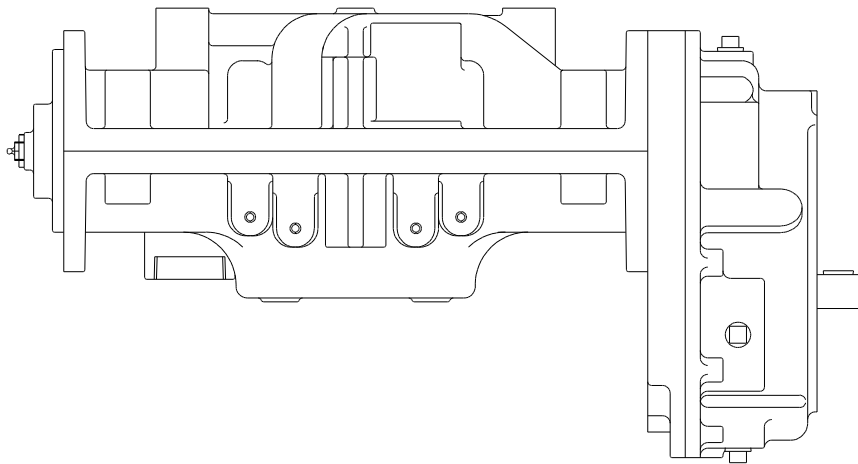

Figure 4. CP-3 Series Pump with K Series Transmission



IL1524

Figure 5. CP-4 Series Pump with K Series Transmission



IL1525

Figure 6. E-301-A, E302-A (CPT-1, CPT-2).

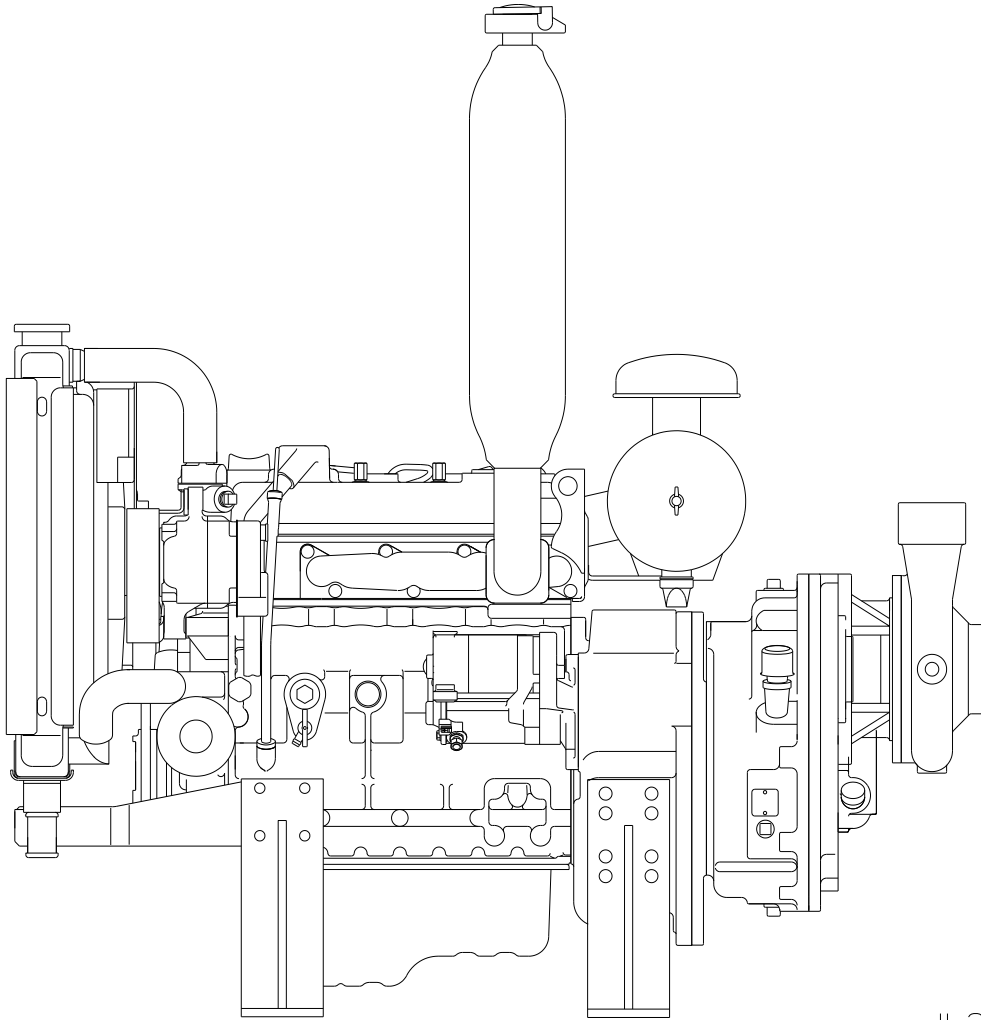

IL2122

Operating Instructions

NOTE: Because of the variety of transmissions available for these pumps, the methods of operating them are not explained in this section. For information on Waterous transmissions, refer to transmission operation instructions.

Pumping from Water Tank

WARNING

Pressure Hazard. May result in personal injury.

Prior to connection or removal of hoses, caps or other closures with pump intake or pump discharge connections, relieve pressure by opening drains or bleeder valves. Bleeder valves should also be used while filling a hose connected to an intake with water.

WARNING

Scalding Water Hazard. May result in serious burns.

When operating the pump, be sure to open at least one discharge valve slightly to prevent the pump from overheating. If the pump runs for a few minutes completely closed, it may heat the water enough to scald someone when the valve is opened. Overheating can damage the packing, seals and other pump parts. If the apparatus builder has installed a by-pass system or other provision designed to prevent overheating, opening a discharge valve may be unnecessary.

WARNING

Unexpected Truck Movement. May result in serious personal injury or death.

Failure to properly shift transmission in accordance to the transmission operating instructions may result in unexpected truck movement which may result in serious personal injury or death.

1. Engage pump in accordance with transmission instructions.
2. **CP-3 Pumps Only:** Switch transfer valve to desired position.

NOTE: As a general rule, keep the transfer valve in **PRESSURE (series) position** when pumping up to 2/3 of the rated capacity of the pump and in **VOLUME (parallel)** when pumping more than 2/3 of the rated capacity. If the pump is operating at a high lift, or pumping a large amount of water, using the **VOLUME position** may be necessary to avoid cavitation.

If high pressure is required (more than 200 psi, 13.8 bar), operating the pump in the **PRESSURE position** may be necessary even if it means closing one or more valves to reduce volume and avoid cavitation.

The transfer valve may be changed from one position to the other while operating the pump. However, medium pressure (approx. 75 psi, 5.2 bar) at low flow (less than 100 gpm, 380 l/m) is desired.

If the transfer valve is moved from **VOLUME** to **PRESSURE** when flowing more than 100 gpm (380 l/m), it may be necessary to momentarily reduce the flow by closing the discharge valves to allow the internal check valve to close and complete the transfer.

WARNING

Discharge pressure change hazard. May cause serious personal injury to the hose line operator.

Changing the position of the transfer valve while the pump is operating may cause significant changes in the discharge pressure, which may result in serious personal injury to the hose line operator.

3. Open valve(s) in piping between water tank and pump intake and at least one discharge valve.
4. Allow about 30 seconds for water to flow into pump.
NOTE: Priming the pump may be necessary because of air trapped in piping.
5. Accelerate engine to obtain desired discharge pressure and capacity.
6. Set relief valves or other pressure governing device to desired pressure.

After Pumping

WARNING

Pressure Hazard. May result in personal injury.

Prior to connection or removal of hoses, caps or other closures with pump intake or pump discharge connections, relieve pressure by opening drains or bleeder valves. Bleeder valves should also be used while filling a hose connected to an intake with water.

1. Disengage pump drive in accordance with transmission instructions.
2. If pumping anything but clean water, remove all intake and discharge caps, open all valves and open all drains. Flush entire system with clean, fresh water for several minutes to remove all traces of impurities.
3. If pump is kept full of water when not in use, make sure water is clean and non-corrosive. Make sure the pump is completely full or completely drained - never partially full.

CAUTION

Freezing water hazard. May cause damage to the pump.

If the pump is exposed to freezing temperatures, drain all water from pump, lines and accessories.

4. Close all drains and install intake and discharge caps.
5. If truck is equipped with a priming pump, operate it until fluid is discharged from priming pump discharge pipe. Also check fluid level in priming tank, and refill if necessary.
6. **CP-3 Pumps Only** - Switch transfer valve back and forth once.

Pumping from Hydrant or in Relay

⚠ WARNING

Pressure Hazard. May result in personal injury.

Prior to connection or removal of hoses, caps or other closures with pump intake or pump discharge connections, relieve pressure by opening drains or bleeder valves. Bleeder valves should also be used while filling a hose connected to an intake with water.

NOTE: As a general rule, keep the transfer valve in **PRESSURE (series)** position when pumping up to 2/3 of the rated capacity of the pump and in **VOLUME (parallel)** when pumping more than 2/3 of the rated capacity. If the pump is operating at a high lift, or pumping a large amount of water, using the **VOLUME** position may be necessary to avoid cavitation.

NOTE: If high pressure is required (more than 200 psi, 13.8 bar), operating the pump in the **PRESSURE** position may be necessary even if it means closing one or more valves to reduce volume and avoid cavitation.

NOTE: The transfer valve may be changed from one position to the other while operating the pump. However, medium pressure (approx. 75 psi, 5.2 bar) at low flow (less than 100 gpm, 380 l/m) is desired.

If the transfer valve is moved from **VOLUME** to **PRESSURE** when flowing more than 100 gpm (380 l/m), it may be necessary to momentarily reduce the flow by closing the discharge valves to allow the internal check valve to close and complete the transfer.

⚠ WARNING

Scalding Water Hazard. May result in serious burns.

When operating the pump, be sure to open at least one discharge valve slightly to prevent the pump from overheating. If the pump runs for a few minutes completely closed, it may heat the water enough to scald someone when the valve is opened. Overheating can damage the packing, seals and other pump parts. If the apparatus builder has installed a by-pass system or other provision designed to prevent overheating, opening a discharge valve may be unnecessary.

⚠ WARNING

Unexpected Truck Movement. May result in serious personal injury or death.

Failure to properly shift transmission in accordance to the transmission operating instructions may result in unexpected truck movement which may result in serious personal injury or death.

1. Engage pump in accordance with transmission instructions.
2. Open intake, hydrant and other valves as necessary to allow water to enter the pump.
NOTE: Bleeder valves should be used while filling a hose connected to an intake with water.
3. **CP-3 Pumps Only:** Switch transfer valve to desired position.

⚠ WARNING

Discharge pressure change hazard. May cause serious personal injury to the hose line operator.

Changing the position of the transfer valve while the pump is operating may cause significant changes in the discharge pressure, which may result in serious personal injury to the hose line operator.

4. Open discharge valves and accelerate engine to obtain desired discharge pressure and capacity.
5. Set relief valves or other pressure governing device to desired pressure.

NOTE: Do not attempt to pump more water than is available from the hydrant or relaying pumper. Always make sure the intake pressure compound gage reading stays above zero.

NOTE: Some fire departments operate at a minimum intake pressure of 10 psi (.7 bar) when pumping from hydrant or in relay to prevent a "soft" intake hose from collapsing.

After Pumping

WARNING

Pressure Hazard. May result in personal injury.

Prior to connection or removal of hoses, caps or other closures with pump intake or pump discharge connections, relieve pressure by opening drains or bleeder valves. Bleeder valves should also be used while filling a hose connected to an intake with water.

1. Disengage pump drive in accordance with transmission instructions.
2. If pumping anything but clean water, remove all intake and discharge caps, open all valves and open all drains. Flush entire system with clean, fresh water for several minutes to remove all traces of impurities.
3. If pump is kept full of water when not in use, make sure water is clean and non-corrosive. Make sure the pump is completely full or completely drained - never partially full.

CAUTION

Freezing water hazard. May cause damage to the pump.

If the pump is exposed to freezing temperatures, drain all water from pump, lines and accessories.

4. Close all drains and install intake and discharge caps.
5. If truck is equipped with a priming pump, operate it until fluid is discharged from priming pump discharge pipe. Also check fluid level in priming tank, and refill if necessary.
6. **CP-3 Pumps Only** - Switch transfer valve back and forth once.

Pumping from Draft

WARNING

Pressure Hazard. May result in personal injury.

Prior to connection or removal of hoses, caps or other closures with pump intake or pump discharge connections, relieve pressure by opening drains or bleeder valves. Bleeder valves should also be used while filling a hose connected to an intake with water.

WARNING

Scalding Water Hazard. May result in serious burns.

When operating the pump, be sure to open at least one discharge valve slightly to prevent the pump from overheating. If the pump runs for a few minutes completely closed, it may heat the water enough to scald someone when the valve is opened. Overheating can damage the packing, seals and other pump parts. If the apparatus builder has installed a by-pass system or other provision designed to prevent overheating, opening a discharge valve may be unnecessary.

WARNING

Unexpected Truck Movement. May result in serious personal injury or death.

Failure to properly shift transmission in accordance to the transmission operating instructions may result in unexpected truck movement which may result in serious personal injury or death.

- a) Position vehicle as near as possible to water supply.
 - b) Avoid humps and sharp bends in intake hose. Make sure no part of hose is higher than pump inlet. (Air pockets in intake hose may cause loss of prime or erratic pump action, and may reduce pump capacity.)
 - c) Make sure all intake connections are tight and discharge valves are closed.
 - d) Immerse intake strainer at least two feet below water surface to prevent pump from drawing air. (Whirlpools forming above intake strainer indicate that strainer is too close to surface of water.)
1. Engage pump in accordance with transmission instructions.
 2. **CP-3 Pumps Only:** Switch transfer valve to desired position.

NOTE: As a general rule, keep the transfer valve in PRESSURE (series) position when pumping up to 2/3 of the rated capacity of the pump, and in VOLUME (parallel) when pumping more than 2/3 rated capacity. If the pump is operating at a high lift, or pumping a large amount of water, using the VOLUME position may be necessary to avoid cavitation.

NOTE: If high pressure is required (more than 200 psi, 13.8 bar), operating the pump in the PRESSURE position may be necessary even if it means closing one or more valves to reduce volume and avoid cavitation.

NOTE: The transfer valve may be changed from one position to the other while operating the pump. However, medium pressure (approx. 75 psi. 5.2 bar) at low flow (less than 100 gpm, 380 l/m) is desired.

If the transfer valve is moved from VOLUME to PRESSURE when flowing more than 100 gpm (380 l/m), it may be necessary to momentarily reduce the flow by closing the discharge valves to allow the internal check valve to close and complete the transfer.

NOTE: To get full capacity, quick prime and maintain pump efficiency:

 **WARNING**

Discharge pressure change hazard. May cause serious personal injury to the hose line operator.

Changing the position of the transfer valve while the pump is operating may cause significant changes in the discharge pressure, which may result in serious personal injury to the hose line operator.

3. Prime the pump (see separate instructions supplied with primer).
4. Open discharge valves, and accelerate engine to obtain desired discharge pressure and capacity.
5. Set relief valves or other pressure governing device to desired pressure.

After Pumping

 **WARNING**

Pressure Hazard. May result in personal injury.

Prior to connection or removal of hoses, caps or other closures with pump intake or pump discharge connections, relieve pressure by opening drains or bleeder valves. Bleeder valves should also be used while filling a hose connected to an intake with water.

1. Disengage pump drive in accordance with transmission instructions.
2. If pumping anything but clean water, remove all intake and discharge caps, open all valves and open all drains. Flush entire system with clean, fresh water for several minutes to remove all traces of impurities.
3. If pump is kept full of water when not in use, make sure water is clean and non-corrosive. Make sure the pump is completely full or completely drained – never partially full.

CAUTION

Freezing water hazard. May cause damage to the pump.

If the pump is exposed to freezing temperatures, drain all water from pump, lines and accessories.

4. Close all drains and install intake and discharge caps.
5. If truck is equipped with a priming pump, operate it until fluid is discharged from priming pump discharge pipe. Also check fluid level in priming tank, and refill if necessary.
6. **CP-3 Pumps Only** - Switch transfer valve back and forth once.

Fire Hose Testing

WARNING

Hose Testing Hazard. May result in serious personal injury.

Due to a potential for catastrophic hose failure during service testing of fire hose, it is vital that safety precautions be taken to prevent exposure of anyone to this danger. Fire pumps on fire department apparatus are not designed for and should not be used for service testing of fire hoses. Hose testing machines should be used for service testing of fire hoses.

NFPA 1962 *Standard for the Inspection, Care, and use of Fire Hose, Couplings, and Nozzles and the Service Testing of Fire Hose* provides requirements and testing procedures for service-testing fire hose at least annually. NFPA 1962 includes procedures for service testing with either a hose testing machine or with a pump on a fire department fire apparatus.

WARNING

Pressure Hazard. May result in serious personal injury.

If a fire pump on a fire department apparatus is used for service testing of fire hoses, the procedures in NFPA 1962 **MUST be followed** including the use of a fire department gate valve with a ¼-inch (6 mm) hole drilled through the gate installed between the fire apparatus discharge outlet and the hose test layout to prevent a volume surge from the pump in the event a hose bursts during testing.

During fire hose testing with a fire pump on a fire department fire apparatus, the fire pump is required to be operated at high discharge pressure with little or no flow out of the apparatus.

WARNING

Scalding Water Hazard. May result in serious burns.

If a fire pump on a fire department apparatus is used for service testing of fire hoses, pump discharge water must be circulated through a by-pass system or discharged through a slightly open discharge valve, or some other provision must be used to prevent overheating. If the pump runs for a few minutes without adequate flow through the pump, water may be heated enough to scald someone when a valve is opened.

CAUTION

If a fire pump on a fire department apparatus is used for service testing of fire hoses, operating the pump at high discharge pressure with little or no flow may result in severe damage to the pump.

Maintenance

Corrosion Protection

Optional Zinc Intake Screens

Once per month check to make sure the intake screens are not clogged or damaged. Also check for corrosion, and replace screens if damage is severe. For the zinc screen to adequately control corrosion, there must be a strong electrical contact between the screen and the fitting. Remove any corrosion, debris or paint from the counter bore that will insulate the screen from the intake fitting. If the screen does not fit tightly, adjust the gap of the slot on the outside diameter of the screen to ensure a tight fit.

NOTE: These screens are die-cast which results in a slight taper from one side to the other. Install the screen with the thinner cross-section facing out to minimize flow restriction.

Figure 7. Zinc Intake Screens

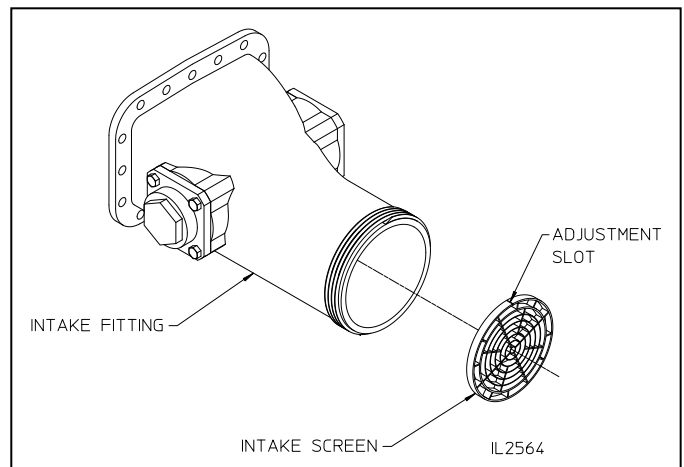

Optional Zinc Anodes

Twice per year, remove the anodes and check for erosion of the zinc elements. Replace the zinc elements if more than half of either of the zinc elements has eroded.

Anodes are normally mounted on the pump intake piping, but they may also be installed in the discharge piping if no intake mounting locations were available. Physical mounting of the anode may be via an NPT tap or bolt-on flange as described below.

NOTE: The zinc must make contact with water to be effective. Do not paint or use any other coating on the zinc elements.

Bolt-on Anodes

Unscrew the (4) hex head screws from the pump. If zinc elements require replacement, unscrew the hex head cap screw.

NOTE: There is no need to remove the threaded anode adapter from the anode flange for zinc element replacement. The screw was installed using thread sealant so higher force than normal may be necessary to remove.

Replace one or both elements as necessary. Install the hex head screw using Loctite 242 (blue) on the screw threads. Mount the anode assembly back on the fitting.

Figure 8. Bolt-on Anodes

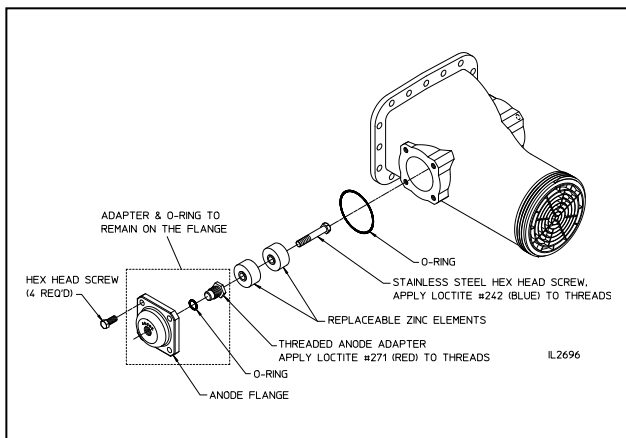

In the event the pump will not be used or exercised for more than 4 weeks, flush the pump with water-based corrosion inhibitor (Cortec VpCI-377) before storage.

1. Mix the corrosion inhibitor solution to a 15% concentration with water.
2. Fill pump with corrosion inhibitor solution.

Lubrication

Outboard Bearing (CP-3, CP-4 Pumps Only)

The outboard bearing is located at the end of the pump opposite the drive end of pump.

Add a good quality, medium consistency, ball bearing grease through the lubrication fitting until it comes out of the relief groove in the fitting. Add grease after every 100 hours of pump operation, or every six months, whichever comes first.

Threaded Anodes

NOTE: The 2-1/2 in. hex is threaded into a bushing that should remain on the pump. Be sure to restrain the bushing when removing the 2-1/2 in. hex.

Unscrew the 2-1/2 in. hex from the pump. If the zinc elements require replacement, unscrew the hex head cap screw.

NOTE: The screw was installed using thread sealant so higher force than normal may be necessary to remove.

Replace one or both elements as necessary. Install the hex head screw using Loctite 242 (blue) on the screw threads. Remove any paint or corrosion from the face around the NPT tap on the pump. Apply thread sealant to the threads and screw the 2-1/2 in. hex into the pipe tap until tight.

Figure 9. Threaded Anodes

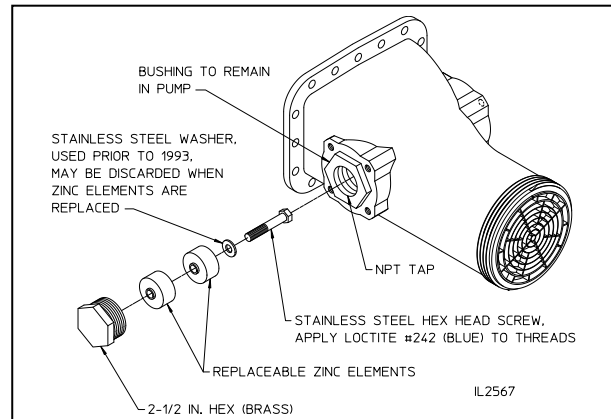

Pump Storage

3. Close intake and discharge ports.
4. Operate pump at reduced speed (idle) for 15-30 seconds to ensure the corrosion inhibitor solution is properly coated within the pump body and the impeller shaft assembly.
5. Drain corrosion inhibitor solution from pump.

Transfer Valve (CP-3 Pumps Only)

Add about one ounce of food grade grease through fitting after 100 hours of pump operation. Make sure transfer valve is completely in one position or the other before lubricating. Then switch transfer valve to other position and grease again.

Packing

Waterous CP-1 and CP-2 pumps use a braided graphite fiber, with reinforced flexible graphite yarns and a high purity graphite filament yarns that appear on the corners as well as throughout the body of the packing. The graphite reinforcement allows the flexible graphite yarns to provide greater tensile strength.

Waterous CP-3 and CP-4 pumps use a combination of Grafoil and braided graphite packing and when correctly installed will provide effective sealing for extended service life before additional packing rings are required. Grafoil should always be used with braided graphite packing in order to absorb the temperature expansion of the Grafoil packing rings. Replacing asbestos or lead foil packing rings (used on pumps built prior to February 1, 1984) with Grafoil may not provide a good seal because of the prolonged break-in period required with a highly polished used shaft. A worn or grooved shaft also should not be used with Grafoil packing.

Packing Removal

WARNING

Truck movement hazard. May cause serious personal injury.

Stop engine, set the parking brake and chock the wheels before going under truck to remove packing.

1. Remove the unbalanced nuts, flat washers and packing gland halves from one end of the pump.
2. Engage the pump per appropriate operating instructions. Operate the pump (multi-stage pumps in VOLUME position). Gradually increase the discharge pressure until the packing is forced out of the stuffing box. Pressure in excess of 300 psi (20.7 bar) may be required.

NOTE: BFG and Grafoil Packing. After adjustments are made, if the travel is used up, there is no need to remove the old packing. Simply add another appropriate ring to the stuffing box.

These types of packing reduce the frictional heat created between the shaft and the I.D. of the packing. By dissipating the heat through the cross section of the packing, the heat is transferred to the packing gland and the pump body.

WARNING

Packing Gland and Pump Body Temperature Hazard. May result in serious burns.

Heat is dissipated through the cross-section of the packing, transferring the heat to the packing gland and pump body.

CAUTION

Pump overheating hazard. May cause damage to the pump.

Circulate enough water through the pump to prevent overheating. Do not pressurize the pump over the maximum discharge pressure of the pump.

3. If all the packing is not forced out, it may be necessary to remove the remaining packing by hand, using a pick or similar device. Waterous has a packing removal tool (P/N 5782) available for this purpose, see Figure 10.
4. For multi-stage pumps repeat the procedure for the opposite end of the pump.
5. Install new packing per Packing Installation Instructions and adjust per instructions.

Figure 10. Packing Removal Tool

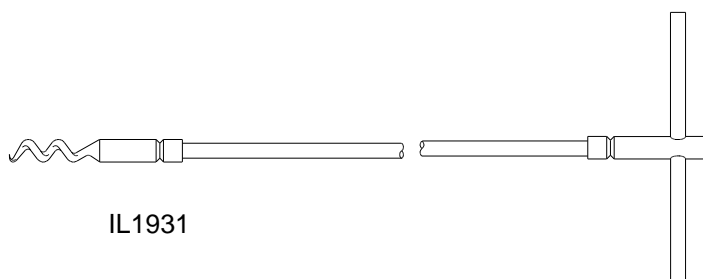

Packing Installation

1. Before installing the new packing, be sure that all of the old packing is removed from the stuffing box.
2. Be sure that the stuffing box and the shaft are clean and free of any packing residue.
3. Lightly lubricate the packing ring I.D. and O.D. with mineral oil, automotive grease or engine oil for installation purposes.
4. Make sure packing is clean.
5. Install packing per appropriate pump configurations, see Figures 11, 12 and 13.
6. Carefully install one ring of packing. With the aid of packing glands, push the packing into the stuffing box as far as possible. Repeat this operation with each ring, staggering the joints at least 90° apart. Install the packing rings until the top of the last ring is about 1/4

inch from the end of the stuffing box (at least 1/8 inch is required for the packing gland nose entrance into the stuffing box), see Figures 11, 12 and 13.

Note: Be sure that the packing joints are staggered at least 90° apart.

7. Install packing glands, nuts and washers. Tighten gland nuts one flat beyond finger tight, see Figures 11, 12 and 13.
- Note: The milled slot on the nut should face the gland.**
8. For multi-stage pumps repeat procedure for opposite end of the pump.
9. Adjust packing as required per instructions on the next page.

Figure 11. CP-1, CP-2 Packing and Gland Installation

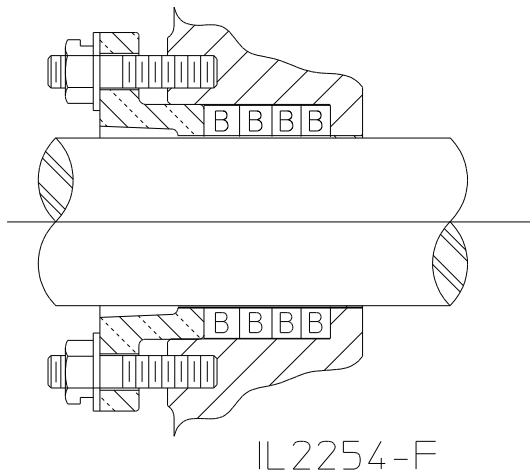

Figure 12. CP-3 Packing and Gland Installation

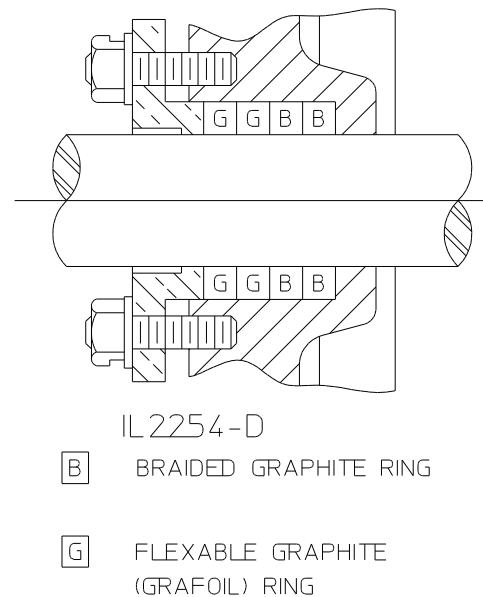
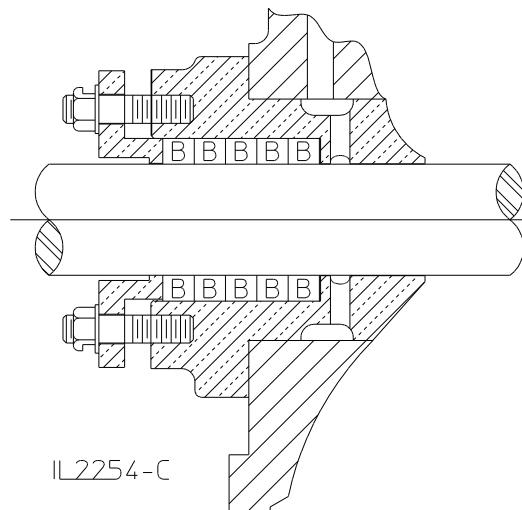

Figure 13. CP-4 Packing and Gland Installation



Packing Adjustment

The pump packing is designed and adjusted to drip slightly during operation. This is to cool and lubricate the packing. It is desirable to adjust the stuffing box to maintain a leakage rate of 10 to 120 drops per minute (60 to 120 drops per minute for CPT-4UH) when operating at a discharge pressure of 150 psi (10.3 bar) (CP-4 pumps at 1000 psi, 69 bar). Operate multi-stage pumps in the VOL-UME position.

Leakage through the braided flexible graphite (BFG) packing may be at zero or diminish to zero leakage and may not respond to loosening of the packing nuts to restore leakage, see Adjustment Step 3. While the packing gland and stuffing box and pump body may reach high temperatures during this time, the impeller shaft will be protected from heat damage.

CAUTION

Pump overheating hazard. May cause damage to the pump.

Circulate enough water through the pump to prevent overheating.

WARNING

Truck movement hazard. May cause serious personal injury.

Stop engine, set the parking brake and chock the wheels before going under truck to remove packing.

1. Engage pump per appropriate operating instructions. Operate the pump at the capacity pressure shown on the serial plate for ten (10) minutes. Operate multi-stage pumps in VOLUME position.

CAUTION

Observe the stuffing box drip rate from the side of the truck.

2. Observe leakage. Normal leakage is 10-120 drops per minute (60 to 120 drops per minute for CPT-4UH).
3. If drip rate is considered high, stop the engine and tighten the packing gland nuts 1/2 to 1 flat (maximum of 1/6 of a revolution). Make appropriate adjustments starting with 1 flat, when approaching the final adjustment reduce to 1/2 flat. This reduces the possibility of over tightening. **Tighten the gland nuts equally to ensure that the packing gland goes on straight.** Gradually reducing leakage during the first hour of operation will result in a better seal over a longer period of time.

CAUTION

Stopping the leakage entirely at this point will cause the packing to overheat.

4. Operate the pump at the capacity pressure shown on the serial plate for two (2) minutes to let packing run in, then observe the drip rate.

WARNING

Packing Gland and Pump Body Temperature Hazard. May result in serious burns.

Heat is dissipated through the cross-section of the packing, transferring the heat to the packing gland and pump body.

5. Repeat steps 3 and 4 until the drip rate is acceptable.
6. For CP-3 and CP-4 adjust the drip rate on one stuffing box until the appropriate rate is obtained, then proceed to the other end of the pump.

NOTE: After adjusting the packing, the pump must pass the following vacuum test described below.

Vacuum Test

1. Remove all caps except openings without valves. Close all discharge, intake and drain valves and other similar openings. Operate priming device to create a vacuum of about 22 in. Hg/.735 atmosphere in pump, then stop primer and engine.
2. Watch the pressure gauge; if vacuum drops more than 10 in. Hg/.334 atmospheres in five (5) minutes, listen for air leaks around the packing gland, gaskets, valves, etc.
3. Replace gaskets, re-adjust packing, repack or otherwise repair source of trouble.
4. Repeat test.

Overheat Protection Manager

Check the electrical circuit by pressing the test button located on the panel plate every 100 hours of pump operation or every six months, whichever comes first.

If the light does not flash, the light bulb or flasher may need replacement (provided all wire connections are solid).