

Installation Instructions

TC20 Series Power Take-Off

Form No.	Issue Date	Rev. Date
T-362	10/12/09	10/13/15

Table of Contents

Introduction 2

PTO Mounting **3, 4**

Installation of Shift Unit:
 See Instruction F-1031, Section 3030, *Shift Installation*

Optional Electronic Tachometer Drive **5**

Final Checks:

Lubrication 5

Testing 5

TC20 Temperature Specifications..... 5

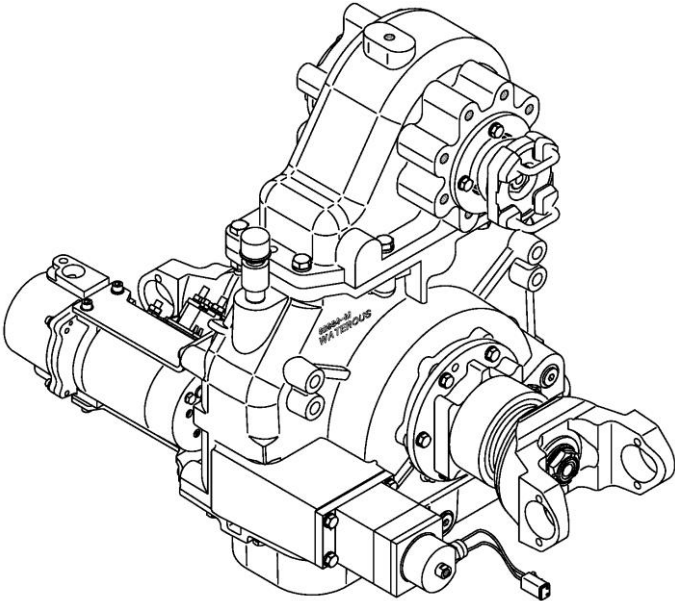

IL3370



Introduction

This instruction covers the installation of a Waterous TC20 Power Take-off.

The following installation instructions are available:

- Priming System, F-1031, Section 3006
- Pneumatic Shift Unit, F-1031, Section 3030

Instructions for pneumatic shift and electronic tachometer drive are covered in this instruction.

Before proceeding with the installation of the TC20 Power Take-off, read the following instructions carefully. Check the appropriate dimensional drawings in the Engineering Manual as needed.

Important Notice: Engine Speed Control Interlock System

For installations of Waterous Power Take-offs in apparatus with electronically controlled engines and automatic chassis engines, an interlock system must be provided to prevent advancement of the engine speed at the PTO operator's panel or by an automatic engine speed control system unless the following conditions are satisfied.

- The parking brake is engaged,
- The PTO is engaged, and
- The chassis transmission is in PTO gear.

In addition, loss of power to the Engine Speed Control Interlock System (ESCIS) must return the engine to idle.

PTO Mounting

For dimensions not shown, refer to Dimensional Drawing DPL83000.

Select a mounting location which will make the PTO and its accessories readily accessible for maintenance and which will make the pump driveshaft parallel with the output shaft of the chassis transmission or bearing housing. Also,

select the location so that when the apparatus is loaded, the universal joints on the propeller shaft will have a proper working angle. Note that the TC20 Series PTO is available with a range of drop sizes (see Table 1 and Figure 1, Dimension "A").

Table 1. TC20 Series PTO Drop Ranges

Model	Dimension A (IN/mm)
TC20B	12.240 / 310.90
TC20C	13.811 / 350.80
TC20D	14.856 / 377.34
TC20E	16.920 / 429.77
TC20F	18.971 / 481.86

***NOTE:** 2.27 ratio drop values shown. Drop values vary for other output ratios, see dimensional drawings for specific drops by ratio.

Table 2 gives maximum universal joint angles for installations where propeller shaft flanges are parallel and yokes are aligned. Refer to this table when positioning a pump to determine proper shaft angles. Be sure to keep at least a minimum of 1° U-joint operating angle, but do not exceed those specified in the table. This is the preferred method of propeller shaft installation. For additional information on this method, or for alternative methods, see driveshaft installation guidelines such as Spicer®/Driveshaft Installation Techniques.

CAUTION

Be sure the propeller shafts used are of the slip-joint design. Frame deflection, temperature changes and similar factors may cause a propeller shaft without slip-joints to produce severe axial loads on the bearings and damage the pump.

Table 2. Maximum U-joint Operating Angles

Driveshaft RPM	Maximum Operating Angle
5000	3.2°
4500	3.7°
4000	4.2°
3500	5.0°
3000	5.8°
2500	7.0°
2000	8.7°
1500	11.5°

NOTE: The angles shown in Table 2 are the maximum U-joint operating angles recommended by Waterous and are directly related to the speed of the driveshaft. Any U-joint operating angle greater than 3° will lower the U-joint life and may cause vibration¹.

¹ From Spicer® Driveshaft Installation Techniques, Form J-3311 dated 5/94

Figure 1. Drop Dimensions

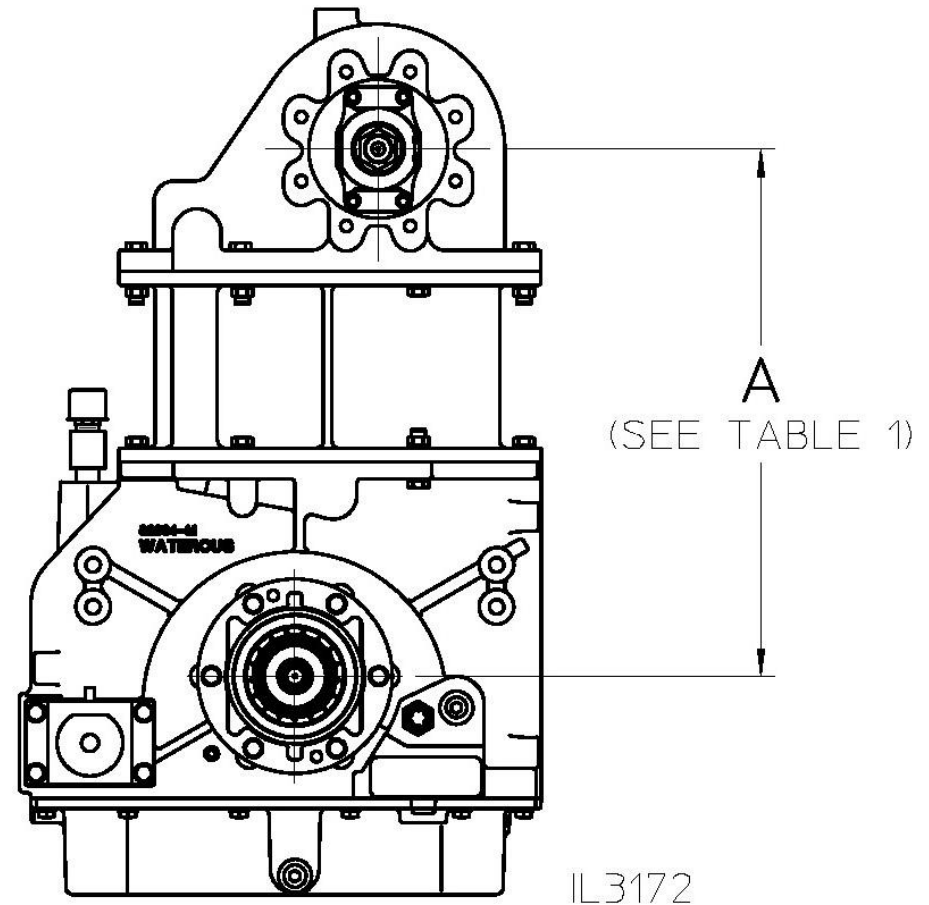

PTO Mounting (Continued)

Figure 2 shows the mounting areas on a TC20 PTO. To mount the PTO to the vehicle chassis, attach brackets (not supplied by Waterloo) on the PTO case. Position the PTO within the vehicle frame rails, blocking temporarily to provide correct shaft angularity. With the PTO in the correct position, secure the brackets (not supplied) to the vehicle frame using a three point mounting technique. The bracket on one side of the PTO should use only one bolt when

attaching to the rail. The bracket on the other side of the transmission should be attached to the chassis rail using two bolts. This three point technique will allow for slight vehicle frame twist without undo stress on the PTO assembly.

NOTE: Tighten the mounting screws to standard torque specifications.

Connect shift unit per Installation Instructions, F-1031, Section 3030.

Figure 2. TC20 PTO Mounting

Anti-seize should be applied to all 3 shaft threads before installing end yoke or companion flange. Do not reuse self-locking nuts. Torque the larger driveline nuts to 475-525 lb-ft.

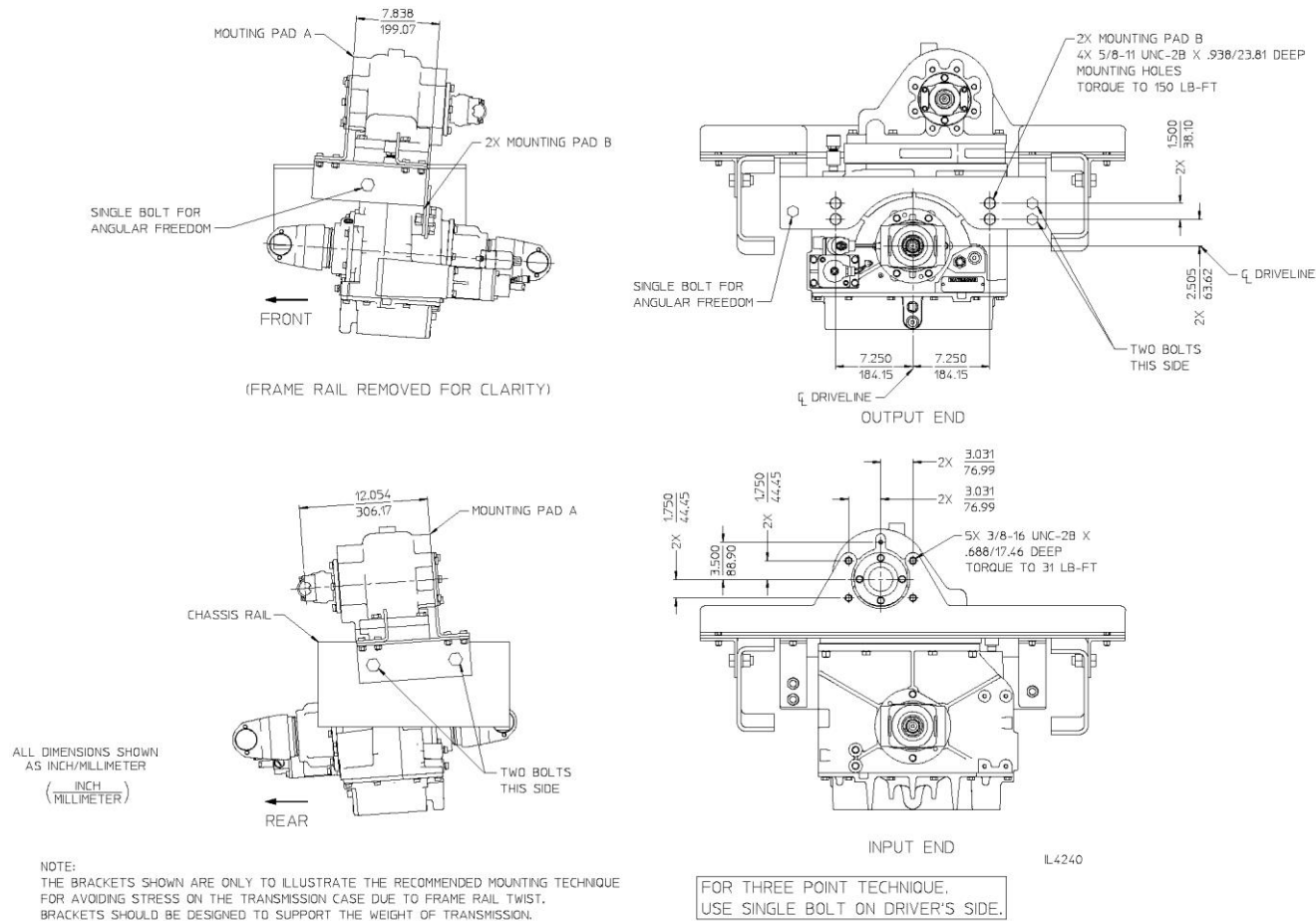

Tachometer

Optional Electronic Tachometer Drive

The magnetic pick-up in the transmission mates with an Amphenol connector (P/N MS3106A-10SL-4S). This connector should be wired to a wall mount receptacle on the operator's panel. To verify the rotational speed of the drive shaft in the TC20 PTO, follow the instructions below.

The frequency (Hz) reading from the tachometer sensor should be multiplied by 10 to obtain driveshaft rpm.

$$\text{Hz} \times 10 = \text{RPM}$$

Final Checks

After the pump, accessories, piping and miscellaneous connections are completely installed, check the points listed below:

Lubrication

Add any type of automatic transmission fluid (ATF) through the fluid level hole or by removing the breather. Approximately 6 quarts is required to fill the transmission when completely drained. Fill to the bottom of "Oil Level" port threads.

CAUTION

Failure to properly lubricate the pump or transmission may result in serious damage to the equipment.

Testing

Perform the tests listed in F-1031, Section 1000, "*Centrifugal Fire Pump Principles of Operation, Inspection Tests and Troubleshooting Guide.*" During the running tests, monitor the smoothness of operation, listen for unusual noises and check for leaks.

TC20 PTO Temperature Specifications

The maximum temperature permitted at transmission external surfaces is 250° F (121° C)