

# SPECIFICATIONS: DECOKING/DESCALING: CMU

Performance Ratings to 2250 GPM and Pressures to 600 PSI



CMU multi-stage centrifugal pumps rugged performance for the pigging market is unmatched by any other pump manufacturer. Waterous offers our multi-stage pumps as either a single unit or available in a self-contained motor pump module.

CMU Pump Performance				
Rating Type	GPM	PSI	L/min	bar
NFPA	1250, 1500, 1750, 2000, 2250	150	4750, 5700, 6625, 7570, 8550	10.3
Max Pressure	600	600	2250	40

## Pump Features

The CMU pump has a two-piece, horizontally-split body with intake and discharge passageways in a single casting and on the same level, providing the lowest possible height, a lower center of gravity, and more room for hose reels, hose beds and other equipment. All passageways are carefully matched to assure the very best hydraulic flow characteristics. The patented ball-type transfer valve has a floating seal design which allows sand to be flushed away to prevent the valve from sticking or jamming. The hydraulically-balanced seal assembly reduces pressure loss and improves pump efficiency. The two-piece, horizontally-split pump body design allows removal of the bottom pump cover without disturbing the main pump body mounting or any piping. After inspection or repair, there is only a single hydraulic flange to seal, which gives you the shortest possible down time. Your Waterous CM equipped apparatus can be back in service faster than apparatus equipped with other brands of pumps.

Braided flexible graphite (BFG) packing is standard on CM pumps. These graphite rings of packing are held in place by a split-bronze gland which is fully removable and adjustable. BFG packing improves heat dissipation, reduces maintenance and minimizes shaft wear. Self-adjusting, spring-loaded mechanical seals are available to eliminate leakage and routine maintenance.

An exclusive two-piece impeller shaft allows true separation of the pump and pump transmission without disassembling either unit. This greatly reduces labor time for repair work.

## Pump Specifications

### Casing

Two-piece, horizontally-split, high-tensile, close grained gray iron or bronze (optional). All passageways are carefully matched to assure the very best hydraulic flow characteristics.

### Wear Rings

Bronze, reverse-flow, labyrinth-type replaceable wear rings increase pump life and keep maintenance costs to a minimum.

### Impellers

Matched bronze impellers, balanced both mechanically and hydraulically for vibration-free operation. Flame-plated impeller hubs are standard to assure longer life despite the presence of abrasives in the water supply.

### Impeller Shaft

Heat-treated stainless steel is ground at all critical areas, polished under packing. An exclusive two-piece impeller shaft allows separation of the transmission from the pump without disassembling either component. This simplifies repair procedures, resulting in less down time.

### Bearings

Three deep-groove, anti-friction ball bearings, located outside the pumping chamber, give support and proper alignment to the impeller shaft assembly. Bearings are oil or grease lubricated, completely separated from the water being pumped, and protected by seal housings, flinger rings and oil seals.

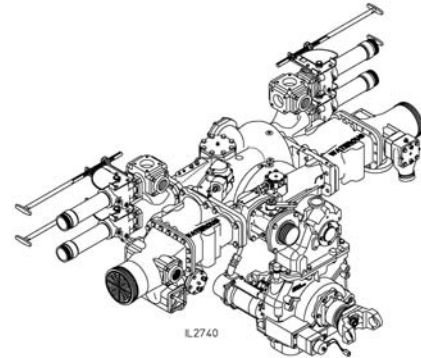

## Pump Specifications *Continued*

### Shaft Seal

Seal housings on packed pumps are equipped with braided flexible graphite (BFG) rings held in place by a split bronze gland which is fully removable and adjustable. BFG packing improves heat dissipation, reduces maintenance and minimizes shaft wear. Self-adjusting, spring-loaded mechanical seals are available which eliminate leakage and routine maintenance.

### Flinger Rings

Located on the impeller shaft between seal housings and bearing housings, flinger rings provide added protection and keep water and foreign matter out of the bearings.

### Oil Seals

Standard lip type for lubrication and additional bearing protection from dirt and water.

### Transfer Valve

Ball-type bronze valve, in removable bronze housings with large waterways for smooth flow. Manual operation is standard, electric operation is optional. The Waterous transfer valve provides smooth transfer to either PRESSURE or VOLUME without sticking.

### Pump Characteristics

The Waterous CMU pump meets or exceeds all requirements of NFPA standard.

The CMU is backed by a Waterous Five-Year Limited Warranty.

For details on Waterous Conditions of Sales, refer to F-2190, *Conditions of Sales* located on the Waterous web site at [www.waterousco.com](http://www.waterousco.com) or by contacting Waterous.

## Industry Leading Sales and Support

When you purchase equipment, not only do you get quality products, you get quality service. Our expert service technicians are the best in the business and they are always happy to answer any service questions you might have.

### Sales/Applications Assistance

Phone: 651-450-5234 (Press 3)  
[pumpsales@waterousco.com](mailto:pumpsales@waterousco.com)

### Service Assistance

Phone: 651-450-5200  
Fax: 800-488-1228  
[service@waterousco.com](mailto:service@waterousco.com)

**RAISING THE BAR ON INNOVATION, RELIABILITY AND SERVICE**

# SPECIFICATIONS: DECOKING / DESCALING: MODEL CMU

## Pump Transmissions Specifications

### C20 Series

**Housings:** High-strength aluminum, three-piece, horizontally-split.

**Drive Ratios:** 1.27, 1.41, 1.48, 1.58, 1.69, 1.79, 1.88, 1.97, 2.03, 2.27, 2.46

**Shafts:** Drive line shafts made from alloy steel forgings, hardened and ground to size, 2.35 inch 46-tooth involute spline.

**Drive and Driven Sprockets**

Made of steel. All sprockets are hardened and have ground bores.

**Drive Chain**

Morse HV® high-strength involute form chain.

**Bearings**

Deep-groove, anti-friction ball bearings give support and proper alignment to the impeller shaft assembly. Bearings are oil-splash lubricated, completely separated from the water being pumped, and protected by a V-ring and oil seals.

**Lubrication System**

An internal lubrication system delivers lubricant directly to the drive chain. This unique design eliminates the need for an external lubrication pump and auxiliary cooling.

**Shift Mechanism**

Constant-mesh, two-position sliding collar that engages all teeth simultaneously. In-cab controlled pneumatic shift. An internal locking mechanism provides a positive lock in PUMP or ROAD position.

## Pump Performance Curves

